

(12) STANDARD PATENT
(19) AUSTRALIAN PATENT OFFICE

(11) Application No. **AU 2018270494 B2**

(54) Title
Adjustable conveyor belt guiderail and related methods

(51) International Patent Classification(s)
B65G 21/20 (2006.01) **B65G 21/22** (2006.01)

(21) Application No: **2018270494** (22) Date of Filing: **2018.05.21**

(87) WIPO No: **WO18/213827**

(30) Priority Data

(31) Number	(32) Date	(33) Country
62/550,023	2017.08.25	US
62/508,700	2017.05.19	US

(43) Publication Date: **2018.11.22**

(44) Accepted Journal Date: **2024.05.02**

(71) Applicant(s)
Span Tech LLC

(72) Inventor(s)
Layne, James L.;Fye, Stephen C.;Barbour, Scott Dayton;Cotton, Aaron;Bell, Savannah

(74) Agent / Attorney
James & Wells Intellectual Property, GPO Box 1301, CANBERRA, ACT, 2601, AU

(56) Related Art
DE 1244652 B
JP S61193919 U
EP 2495190 A1
EP 1084905 A1
US 10753785 B2



(51) International Patent Classification:
B65G 21/20 (2006.01) *B65G 21/22* (2006.01)

(21) International Application Number:
PCT/US2018/033665

(22) International Filing Date:
21 May 2018 (21.05.2018)

(25) Filing Language: English

(26) Publication Language: English

(30) Priority Data:
62/508,700 19 May 2017 (19.05.2017) US
62/550,023 25 August 2017 (25.08.2017) US

(71) Applicant: SPAN TECH LLC [US/US]; 1115 Cleveland Avenue, Glasgow, KY 42141 (US).

(72) Inventors: LAYNE, James, L.; 241 Fisher Lane, Bowling Green, KY 42103 (US). FYE, Stephen, C.; 120 Sheila Drive, Glasgow, KY 42141 (US). BARBOUR, Scott, Dayton;

150 Hillwood Rd, Glasgow, KY 42141 (US). COTTON, Aaron; 203 Lincoln Rd., Glasgow, KY 42141 (US). BELL, Savannah; 7675 Edmonton Rd., Glasgow, KY 42141 (US).

(74) Agent: DORISIO, Andrew, D. et al.; King & Schickli, PLLC, 800 Corporate Drive, #200, Lexington, KY 40503 (US).

(81) Designated States (unless otherwise indicated, for every kind of national protection available): AE, AG, AL, AM, AO, AT, AU, AZ, BA, BB, BG, BH, BN, BR, BW, BY, BZ, CA, CH, CL, CN, CO, CR, CU, CZ, DE, DJ, DK, DM, DO, DZ, EC, EE, EG, ES, FI, GB, GD, GE, GH, GM, GT, HN, HR, HU, ID, IL, IN, IR, IS, JO, JP, KE, KG, KH, KN, KP, KR, KW, KZ, LA, LC, LK, LR, LS, LU, LY, MA, MD, ME, MG, MK, MN, MW, MX, MY, MZ, NA, NG, NI, NO, NZ, OM, PA, PE, PG, PH, PL, PT, QA, RO, RS, RU, RW, SA, SC, SD, SE, SG, SK, SL, SM, ST, SV, SY, TH, TJ, TM, TN, TR, TT, TZ, UA, UG, US, UZ, VC, VN, ZA, ZM, ZW.

(54) Title: ADJUSTABLE CONVEYOR BELT GUIDERAIL AND RELATED METHODS

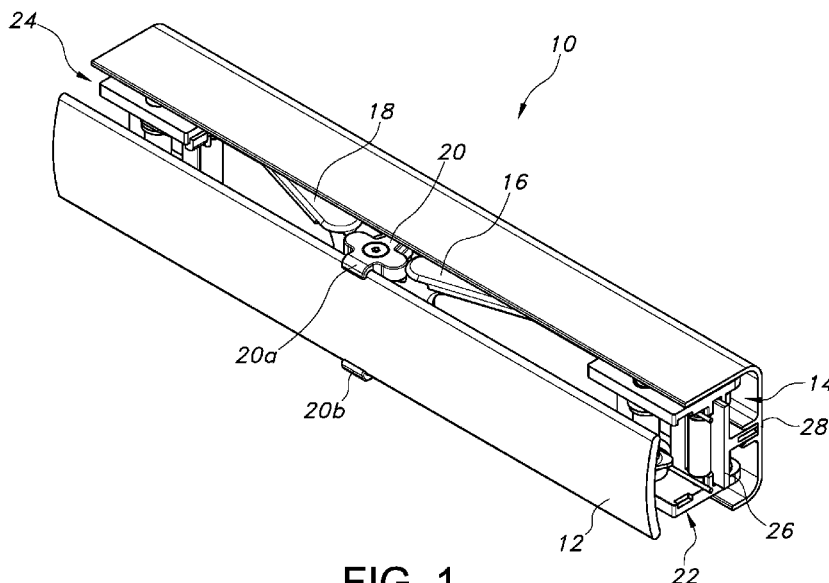

FIG. 1

(57) Abstract: An apparatus for guiding products along a conveyor in a conveying direction. The apparatus includes a first guiderail for at least partially forming a conveying path for articles on the conveyor. A guiderail adjuster includes a flexible or collapsible support, which may take the form of a linkage, and which provides support for the first guiderail along the conveyor. The flexible or collapsible support is adapted for being extended and retracted along a support rail extending in the conveying direction to selectively position the first guiderail relative to the conveyor, and thereby alter (increase or decrease) the width of the conveying path. Related methods are also disclosed.



(84) Designated States (*unless otherwise indicated, for every kind of regional protection available*): ARIPO (BW, GH, GM, KE, LR, LS, MW, MZ, NA, RW, SD, SL, ST, SZ, TZ, UG, ZM, ZW), Eurasian (AM, AZ, BY, KG, KZ, RU, TJ, TM), European (AL, AT, BE, BG, CH, CY, CZ, DE, DK, EE, ES, FI, FR, GB, GR, HR, HU, IE, IS, IT, LT, LU, LV, MC, MK, MT, NL, NO, PL, PT, RO, RS, SE, SI, SK, SM, TR), OAPI (BF, BJ, CF, CG, CI, CM, GA, GN, GQ, GW, KM, ML, MR, NE, SN, TD, TG).

Published:

- *with international search report (Art. 21(3))*
- *before the expiration of the time limit for amending the claims and to be republished in the event of receipt of amendments (Rule 48.2(h))*

**ADJUSTABLE CONVEYOR BELT GUIDERAIL
AND RELATED METHODS**

This application claims the benefit of U.S. Provisional Patent Application Ser. Nos. 62/508,700, filed May 19, 2017, and 62/550,023, filed August 25, 2017, the disclosures of which are fully incorporated herein by reference.

Technical Field

[0001] This disclosure relates to the article conveying arts and, in particular, to an adjustable conveyor belt guiderail and related methods.

Background

[0002] Conveyors typically have rails positioned along each side of the conveyor chain or belt to guide an article along a conveying path. Articles travel between the rails, which are positioned to ensure that the articles remain on the conveying path. When a larger or smaller article is conveyed, or the width of the conveying path otherwise needs to be adjusted to accommodate an increased or reduced article flow, the guiderails must be adjusted to fit the situation.

[0003] Conventional guiderail adjustment systems use extending guide rods, which support a bracket attached to the guiderail. When the guiderails need to be adjusted, the rods can be moved along the brackets, which is typically manually done. These guide rods also protrude outwardly away from the conveyor and into the surrounding area, thus increasing the overall width and footprint of the conveyor. The guiderails including rigid rods also create an unappealing look, since the extended portions of the rods project from the conveyor sides.

[0004] Accordingly, a need is identified for an adjustable guiderail that overcomes the foregoing limitations and possibly others that have yet to be realized.

Summary

[0005] According to one aspect of the disclosure, an apparatus for supporting a guiderail for guiding one or more articles being conveyed along a conveyor in a conveying direction is provided. The apparatus comprises a support rail and at least one adjuster for adjusting the position of the guiderail relative to the conveyor in a direction transverse to the conveying direction. The at least one adjuster comprises a collapsible support for engaging the support rail and supporting the guiderail. The at least one collapsible support is adapted for being extended and retracted to selectively position the guiderail relative to the support rail.

[0006] In one embodiment, the collapsible support comprises a pair of arms connected for relative pivoting movement at one end, and each connected to a shuttle for engaging the support rail at another end. The arms may be pivotably connected to a connector, which may include a receiver adapted for receiving a portion of the guiderail. The connector includes an extension for engaging the support rail to prevent the pair of arms from reaching a locked position.

[0007] Each shuttle comprises a retainer for engaging the support rail. Each shuttle may include at least one roller for rotatably engaging the support rail. An actuator may be provided for actuating the movement of the shuttles along the support rail toward each other to extend the guiderail and away from each other to retract the guiderail. The actuator may comprise a cable, and each shuttle may comprise a clamp for clamping the shuttle to either a forward run of the cable or a return run of the cable. The support rail may support one or more pulleys for guiding the cable, and a motor may be provided for moving the cable to and fro along an endless path.

[0008] According to a further aspect of the disclosure, an apparatus for supporting a first guiderail for guiding one or more articles being conveyed along a conveyor in a conveying direction is provided. The apparatus comprises a first collapsible support for supporting the first guiderail, the first collapsible support adapted for being extended and retracted to selectively position the first guiderail. A first actuator is provided for actuating the first collapsible support for extending or retracting the guiderail.

[0009] The first actuator comprises a cable in one embodiment, but may take the form of any flexible connector (such as a ribbon, tape, chain, or the like). The first collapsible support includes a shuttle adapted for connecting to either a forward run of the cable or a return run of the cable. A pulley is provided for guiding the cable, as is a motor for moving the cable to and fro in an endless path.

[0010] The apparatus may include a plurality of first collapsible supports for supporting the first guiderail. In such case, the actuator is for simultaneously actuating each support for extending or retracting the first guiderail.

[0011] A second guiderail may also be provided for guiding the one or more articles being conveyed along the conveyor in the conveying direction, along with a second collapsible support for supporting the second guiderail. The second collapsible support may be adapted for being extended and retracted to selectively position the second guiderail relative to the first guiderail. The second collapsible support may be actuated by the first actuator, or a second actuator for extending or retracting the second guiderail independent of the first guiderail. The first actuator may be adapted for actuating the first collapsible support for forming a first zone on the conveyor having a first width and the second actuator is adapted for actuating the second collapsible support for forming a second zone on the conveyor having a second width different from the first width.

[0012] Still a further aspect of the disclosure pertains to an apparatus for supporting a guiderail for guiding one or more articles being conveyed along a conveyor in a conveying direction. The apparatus comprises a support for supporting the guiderail, the support comprising a flexible joint. The support comprises a linkage, which may include first and second arms pivotally connected to a connector for forming the flexible joint. Each of the first and second arms may be adapted for translating along a support rail extending in the conveying direction. The connector may also be adapted for engaging the guiderail (fixedly or slidably). An actuator may also be provided for actuating the support to move the guiderail to and fro in a direction transverse to the conveying direction.

[0013] A further aspect of this disclosure pertains to a guiderail for a conveyor. The guiderail comprises a first guiderail portion having a first leg extending in a conveying

direction and a second guiderail portion having a second leg extending in the conveying direction, the first and second legs being captured by at least one receiver. The first and second legs may overlap in a vertical direction.

[0014] This disclosure also pertains to a method for adjusting the width of a conveying path on a conveyor having a conveying direction. The method may comprise actuating a flexible support to extend and retract a guiderail in a direction transverse to the conveying direction. The flexible support may comprise first and second arms having a flexible joint at one end, and the actuating step comprises moving the first and second arms together from a greater angle to a reduced angle to cause the flexible joint to extend the guiderail. The actuating step may also comprise moving the first and second arms apart from a reduced angle to a greater angle to cause the flexible joint to retract the guiderail. The actuation may be manual or automatic.

[0015] This disclosure also pertains to a method for adjusting a width of a conveying path on a conveyor having a conveying direction. The method comprises supporting a guiderail by way of a plurality of flexible supports, and actuating a single actuator to simultaneously actuate the plurality of flexible supports to extend or retract the guiderail for controlling the width of the conveying path. The actuating step may comprise moving a cable connected to the flexible supports in an endless path.

[0016] The flexible supports may each comprise a pair of arms. Each arm may be connected to a shuttle for engaging a support rail extending generally parallel to the guiderail. The actuating step may comprise moving the shuttles together or apart along the support rail to extend or retract the flexible supports and hence the guiderail.

Brief Description of the Drawing Figures

[0017] The accompanying drawing figures incorporated herein and forming a part of the specification, illustrate several aspects of the disclosed inventions and, together with the textual description, serve to explain certain principles thereof. In the drawing figures:

[0018] Figure 1 is a top perspective view of one embodiment of a single conveyor guiderail adjuster according to one embodiment of the disclosure;

- [0019] Figure 2 is a bottom perspective view of the adjuster of Figure 1;
- [0020] Figures 3, 4, and 5, are top, rear, and bottom views of the adjuster of Figure 1;
- [0021] Figure 6 is a front view of the adjuster of Figure 1;
- [0022] Figures 7 and 8 are left and right side views of the adjuster of Figure 1;
- [0023] Figure 9 is a perspective view of a collapsible guiderail support forming part of the adjuster of Figures 1-8;
- [0024] Figure 9A is an exploded view illustrating a manner of connecting an arm to one of the supports (shuttles) for pivoting movement;
- [0025] Figure 9B is a top view of the assembled configuration of Figure 9A;
- [0026] Figure 9C is a cross-sectional view of the arrangement of Figure 9A when assembled, taken along line 9C-9C of Figure 9B;
- [0027] Figures 10 and 11 are top views of the support of Figure 9 in an extended and retracted condition;
- [0028] Figure 12 is a rear view of the support of Figure 9;
- [0029] Figure 13 is a perspective view of a shuttle for connecting to the support for manual operation;
- [0030] Figure 14 is an exploded perspective view of the shuttle of Figure 13;
- [0031] Figure 15 is a perspective view of a shuttle for connecting to the support for automated operation;
- [0032] Figure 16 is an exploded perspective view of the shuttle of Figure 15;
- [0033] Figure 16A is a partially cross-sectional top view of the shuttle of Figure 15;
- [0034] Figure 17 is a side view illustrating aspects of an actuator for actuating the adjustable guiderail support;
- [0035] Figure 18 illustrates a tensioner for a cable forming part of the actuator for the adjustable support;
- [0036] Figures 19, 20, 21, 22 and 23 illustrate alternative forms of actuators;
- [0037] Figures 24, 25, and 26 illustrate a system comprising two opposed guiderails associated with a plurality of adjusters;

- [0038] Figures 27 and 28 illustrate various aspects of an extendable guiderail;
- [0039] Figures 29 and 30 illustrate one manner of guiding the cable along the support rail;
- [0040] Figure 31 and 32 illustrate guides for guiding an endless cable along a curved section of a support rail for the adjusters; and
- [0041] Figures 32, 33, and 34 are schematic views illustrating the creation of various zones using the adjustable guiderails according to the disclosure.
- [0042] Reference will now be made in detail to the present preferred embodiments of an adjustable guiderail for a conveyor, examples of which are illustrated in the accompanying drawing figures.

Detailed Description

[0043] With reference to Figures 1-9, one possible embodiment of a guiderail adjuster 10 forming one aspect of the invention is illustrated. As illustrated, the adjuster 10 may be adapted to connect with a guiderail 12 for guiding articles along a conveying path and in a conveying direction D (see, e.g., Figure 19). The guiderail 12 may be supported by a support 14 forming a part of the adjuster 10, which may be flexible or collapsible (that is, able to be folded into a more compact shape). The adjuster 10 including the support 14 is thus capable of extending or retracting the guiderail 12 to change the relative position of the conveying path, without increasing the overall width of the associated conveyor in a transverse direction as a result of the adjustment.

[0044] In one embodiment, the support 14 may comprise links in the form of first and second supports or arms 16, 18 connected to each other. The arms 16, 18 are rigid in the vertical direction, but pivotally connected at their inner end portions, such as by a connector 20. The arms 16, 18 and connector 20 thus create a linkage (which may be in the form of a two bar linkage, but other forms could be used).

[0045] At the opposite end, each arm 16, 18 is connected to a structural part designed to reduce or eliminate friction or provide support or bearing. In the illustrated embodiment, this structure takes the form of a movable bolster or shuttle 22, 24 adapted to

frictionally (by sliding or rolling) engage an elongated support rail 26, which extends generally parallel with the guiderail 12 in the conveying direction D. Consequently, these connections and the relative movement established allow for flexing or collapsing of the support 14 in a direction transverse to the conveying direction D.

[0046] The support 14 is also adapted to connect with the guiderail 12. In the illustrated embodiment, this is achieved by providing the connector 20 with one or more receivers, such as clips 20a, 20b (which as discussed in further detail below may provide engagement such that the guiderail 12 is fixed in position, or may be arranged to allow for relative sliding movement). As can be appreciated from Figure 6, the arrangement is such that the overall adjuster 10 has a very low vertical profile, with a height only slightly greater than the height of the guiderail 12. As can be seen in Figures 1-8, an optional cover 28 may also be provided (removed in Figure 9), which may engage the support rail 26 and provide a measure of protection for the movable parts of the adjuster 10, but without interfering with their relative movement and operation.

[0047] With reference to Figures 9 and 12, the nature of the pivoted connection of the arms 16, 18 forming the support 14 for the guiderail in one embodiment is shown. Each arm 16, 18 may be provided with a trunnion 16a, 18a, the ends of which are received and rotatably captured within upper and lower receivers 20c on either side of the connector 20. However, alternative configurations could be used, such as a simple hinge (with a mechanical pin or a living hinge). In any case, movement of the shuttles 22, 24 along the support rail 26 towards each other causes the connector 20, and hence, the associated guiderail (not shown) to move along an adjacent conveying surface in a direction transverse to the conveying direction. The movement is considered a flexible one, in that the pivoting of the arms 16, 18 relative to the connection allows flexing of the flexible joint thus formed. Likewise, movement of the shuttles 22, 24 in the opposite direction (farther away from each other) causes the arms 16, 18 to flex relative to each other (and connector 20) and thereby retract the guiderail 12.

[0048] Allowing the arms 16, 18 forming the linkage to reach a “bottomed out” ($\beta=180$ degrees or more) and potentially locked position may be undesirable (especially

when the actuation of the adjusters 10 is automated, as compared to manual). Thus, as can be appreciated from Figures 10 and 11, this condition may be avoided by providing the side of the connector 20 opposite the guiderail 12 with a protrusion or extension 20d projecting transverse to the conveying direction, which thus serves to define the maximum flexing of the joint formed between the arms 16, 18. This protrusion or extension 20d of the connector 20 may be sized and positioned to engage the support rail 26 in the fully collapsed position of the linkage, and thus prevent it from bottoming out and becoming locked in position. Of course, the protrusion could also be provided on one or both of the arms 16, 18, or even on the support rail 26, to achieve a similar result.

[0049] As can be appreciated with reference to Figures 10, 11, and 12, by way of being selectively extended or retracted, the support 14 creates an enhanced level of adjustability for an associated guiderail 12. The adjustments may be achieved in an easy and efficient manner, and without remarkably increasing the footprint of the overall conveyor system. Specifically, extending or retracting the support 14 allows the guiderail 12 pivotally attached thereto by virtue of connector 20 to be configured to provide a variable width conveying path for a number of differently sized articles to be conveyed. For example, when a smaller sized article is desired to be conveyed, the guiderail 12 need only be moved in an inward or inboard direction I transverse to the conveying direction D, thereby causing it to collapse in this direction (and thus causing the flexible joint to assume an acute angle α , such as for example as little as 5 degrees in the illustrated example, and possibly lower in the event the arms 16, 18 may be arranged parallel to each other)). In other words, the arms 16, 18 move from a position where the relative angle between them is greater to one in which it is reduced or smaller. This narrows the conveying path, and thus allows for a readily customizable arrangement for guiding a variety of differently sized articles.

[0050] Likewise, if it is desired to convey a larger sized article/object or otherwise extend the width of the conveying path relative to the underlying conveyor, the guiderail 12 need only be moved in an outward or outboard direction O transverse to the conveying direction D (and thereby flexing the joint so as to create a large, obtuse angle β between

the arms 16, 18, which may be up to but not including 180 degrees, and as shown is limited by the presence of the protrusion 20d to prevent a lock out condition). In other words, the arms 16, 18 move from a position where the relative angle between them is smaller to one in which it is greater. In all cases, it can be appreciated that no rod or like structure projecting outwardly from the support rail 26, and thus the overall width of the arrangement does not change as a result of the extension or retraction. The resulting conveyor system may thus have a smaller footprint than would otherwise be the case if transversely extending rods and corresponding mounts were utilized.

[0051] The adjustment of the support 14 may be manually or automatically done. In the manual version, and with reference to Figures 13 and 14, each shuttle 22, 24 may be provided with a retainer 30 for use in selectively engaging the support rail 26 and thereby holding the shuttle in the desired position. In the illustrated embodiment, the retainer 30 comprises a post 32 supporting a pivotally mounted lever 34, such as by way of snap-fit engagement with a clip 32a. The inside of the lever 34 includes a wedge 36, which is sized and positioned for not engaging the rail 26 in one position, but frictionally engaging it in a different position (note positions 34' (free) and 34'' in Figure 9 (retained)). Opposed plates 38, 40 may be retained by a fastener F to hold the post 32 in position, and each plate 38, 40 may include a guide 42 for slidably receiving a portion of the support rail 26. The plates 38, 40 may also include apertures 38a, 40a for receiving a corresponding fastener (such as a keyway plug 16c; see Figures 9A, 9B, and 9C) depending from a proximal end of each arm 16, 18 for pivotally connecting the ends of the arms 16, 18 with the shuttles 22, 24.

[0052] As can be appreciated, by disengaging the retainer 30 using lever 34, the associated shuttle 24 is free to move to and fro, such as by sliding, along the support rail 26, and thereby extend or retract the support 14 and, hence, the associated guiderail 12. When a position is reached corresponding to the desired extension or retraction of the guiderail 12, the retainer 30 may be reactivated to establish fixed engagement with the support rail 26. As can be appreciated, it is only necessary to move one of the shuttles 22, 24 to achieve the desired extension or retraction of the guiderail 12 in view of the collapsible nature of the support 14 created by the pivotably connected arms 16, 18.

[0053] The shuttles 22, 24 may also be readily adapted to work in an automated environment. Specifically, at least one, and potentially each shuttle 22, 24 may be adapted to engage an actuator for causing movement to and fro along the support rail 26, depending on the degree of actuation, and thus extending or retracting the arms 16, 18. As shown in Figure 17, the actuator may comprise a connector for connecting with the shuttles 22, 24, such as a flexible cable 44 (which may be a coated, stranded cable, a chain, or any other form of connector for transmitting movement). The cable 44 may extend over pulleys 46 at each end (only one shown in Figure 17 mounted to one end of the support rail 16, but the arrangement would essentially be the same as shown at the opposite end of the support rail 26; *see, e.g.*, Figure 19). The arrangement thus forms an endless loop (which may be associated with plural adjusters 10, as outlined further in the following description).

[0054] To cause the cable 44 to traverse the endless path, it may be entrained around a driver, such as capstan 48, which may be associated with a motor 50 (e.g., a servomotor) also forming part of the actuator in this embodiment. As shown in Figure 18, the cable 44 may also be provided with a tensioner, such as a turnbuckle 44a, to allow for the tension to be adjusted as necessary or desired.

[0055] In this example, and with reference to Figure 16, each plate 38, 40 may be provided with a retainer 52 for selectively engaging the cable 44. The retainer 52 may comprise a clamp in the form of a pivotable cam 54 (only upper one shown in Figure 16), but could take other forms as well (e.g., a bolt with a flange for capturing a portion of the cable 44 against a corresponding surface of the shuttle). The cam 54 may be journaled on a reduced diameter end 56a of a post 56, which may be held in place by a fastener F.

[0056] In the illustrated example, and with reference to Figures 16 and 16A, the cam 54 includes an enlarged, rounded inner face 54a for engaging and pressing the cable into engagement with a frictionally enhanced portion 55 of the plate 38, 40 (which may be identical, but inverted; in other words, plate 38 is identical in form to plate 40 in Figure 16, so it can be understood that the upper plate includes frictionally enhanced portion 55), and a free end 54b adapted for tactile engagement for movement between the hold and release position. A lock, such as a removable locking tab 58 with flexible legs for engaging a

projection 58a in a snap fit engagement, may also be provided for engaging and fixing the cam 54 in the locked or closed condition, thus engaging the cable (shown in phantom line in Figure 16A). A roller or pulley 60 may be rotatably journaled at the opposite, reduced diameter end 56b of post 56 (upper when the cam 54 is at the lower plate 38; lower when the cam 54 is at the upper plate 38, as shown in Figure 16).

[0057] As can be appreciated, the cable 44 has a forward run and a return run in view of the endless loop established. By connecting one shuttle 22 to the upper run using the clamp (cam 54) located as shown in Figure 16, and connecting the other shuttle 24 to the return run using a clamp (cam 54 on plate 40, as per Figure 16A) at a corresponding location, actuation using a single actuator thus causes the shuttles 22, 24 to move toward or away from each other, thereby flexing the joint of the support 14 created by arms 16, 18 and extending or retracting the guiderail 12. The alternate run of the cable 44 that is not fixed to the shuttle 22, 24 simply engages the roller/pulley 60, and thus does not impede the relative movement.

[0058] With continued reference to Figure 16, each shuttle 22, 24 may also be provided with rollers 62 to create low-friction engagement with the support rail 16. The rollers 62 may comprise individual rollers 62a connected to the plates 38, 40 by fasteners 64 and arranged for engaging an outer face of the support rail 16, as well as rollers 62b journaled in the plates 38, 40 for engaging the inside face of the support rail 16. As can be appreciated, the spaced rollers 62a allow for a portion of the rail 16 to pass for engaging and supporting the cover 28.

[0059] Alternative forms of actuation are possible, which advantageously may use a single actuator for activating plural adjusters 10 for adjusting the width of the conveying path. For example, as shown in Figure 19, the connector, such as cable 44, may be associated with a rack 66, which is arranged for engaging a rotatable pinion 68. In view of the endless nature of the cable 44, and the corresponding connections with the shuttles 22, 24 as described above, actuation of the pinion 68 in one direction causes the simultaneous actuation of plural adjusters 10. This advances the guiderail 12 (shown as two disconnected portions with phantom portion for purposes of illustration) in the transverse direction T of

the conveyor C (which as indicated has a conveying path P formed by a conveying surface (chain or belt B) in the conveying direction D, and note reduced width path P' as a result of the advance of the guiderail 12 in the transverse direction). Specifically, rotating the pinion in a clockwise direction moves the rack to the right in Figure 19, and in view of the connection of the forward run of the cable 44 with shuttles 22 of each guiderail adjuster 10, and the return run with shuttles 24, causes the advancement illustrated. Reversing the direction of rotation of pinion 68 causes the opposite movement to occur.

[0060] The actuation of the adjusters 10 associated with the conveyor C may again be manual or automated. Thus, as shown in Figures 20-22, a hand wheel 70 may be connected to the associated conveyor C and rotated to cause the actuation of one or more of the adjusters 10 (basically, as many as are connected to a single connector or cable 44, which could be any number (2, 5, 10, 20 or more), depending on the strength of the actuator arrangement used. Figure 23 illustrates the use of a motor 72 (e.g., servomotor) for automated operation.

[0061] Figures 24-26 illustrate an overview of a possible arrangement of the adjustable guiderail support system 100 incorporating a plurality of adjusters 10 for use in connection with a conveyor having a conveying path (not shown). Opposed inner and outer guiderails 12a, 12b are shown for guiding articles (not shown) along the conveying path. The adjustable guiderail supports 14a, 14b are supporting inner guiderail 12a and the adjustable guiderail support 14c is supporting outer guiderail 12b. Thus, if it is desired adjust the conveying path width W to accommodate differently sized articles (or groups thereof), guiderail 12a (along with guiderail supports 14a, 14b) and guiderail 12b (along with guiderail support 14c and any others present) may be moved. The movement may again be manual or automatic using a single actuator (including cable 44) transverse the conveying direction D along each support rail 26 (with an associated motor, the operation of which may be coordinated by a single controller) in order to widen or narrow the conveying path width W (note smaller width W' in Figure 25, and even smaller width W'' in Figure 26, which may correspond to a single row of articles being conveyed, such as bottles or cans). In such situations, it may be desirable to have the receivers (e.g., clips

20a, 20b) firmly engage the guiderail 12a, 12b at every other adjuster 10, but slidably engage at others, to allow for the desired extension and retraction.

[0062] Figures 27-28 illustrate that the guiderail 12 may comprise an extendable joint 74 comprised of portions, such as legs 12c, 12d, having a reduced vertical dimension (basically each equal to one half of the overall guiderail height). These legs 12c, 12d may overlie each other or overlap in a vertical direction, and are slidably received in receivers 76, which may take the form of C-shaped clamps that allow for relative movement of the legs (toward a common center during retraction of the guiderail 12 and away from it during extension). The receivers 76 thus retain the legs 12c, 12d together, yet capable of relative movement in the conveying direction during extension and retraction of the associated guiderail portions. This allows for the guiderail 12 to provide the desired extension and retraction, such as via supports 14, to accommodate a particular article being conveyed or form a particular conveying path. Hence, one or both of the legs 12c, 12d may be curved, but use of the supports 14 in connection with straight portions that are connected by the extendable joints is also possible. It can also be appreciated from Figure 28 that the extendable joints 74 allow for opposing guiderails 12 to extend or retract different amounts, which may occur when one is associated with an inside curve and the other with an outer curve.

[0063] Depending on the size or shape of the underlying conveyor C, it may also be desirable to provide a guide intermediate the adjusters 10 for guiding the connector, such as cable 44. As shown in Figures 29-31, this may be achieved using the manual shuttle 22 or 24 of Figures 13 and 14, which may be equipped with pulleys 60 for engaging the upper and lower runs of the cable 44. The shuttles 22, 24 may be selectively positioned using the associated retainers 30. Stationary brackets 78 may also be provided with upper and lower guides 78a, 78b for guiding the respective runs of the cable 44.

[0064] Figures 32-33 schematically illustrate a possible application of a plurality of the adjusters 10a . . . 10n to create zones of different widths in a single conveyor or conveyor system (e.g., comprised of multiple conveyors). As shown in Figure 32, a first series of adjusters 10a associated with an underlying conveyor C may be used to provide

an upstream portion of the conveyor with guiderails 12a, 12b spaced farther apart, thus forming a first zone Z1, and a second series of adjusters 10b may be used to place downstream guiderails 12e, 12f spaced closer together, thus forming a second zone Z2. The adjusters 10a, 10b may be manually adjusted, or associated with different actuators (e.g., a cable system, as described above). Later in time, as indicated in Figure 33, the adjusters 10a, 10b may be altered to make the zones Z1, Z2 the same width, or for zone Z2 to be wider than zone Z1, as indicated in Figure 34. As can be appreciated, the material of the guiderails 12a-12b may be flexible or include flexible interconnections (including the joints 74 described above) to allow for the relative movement, which is exaggerated in the schematic figures for purposes of illustration).

[0065] This disclosure may be considered to pertain to any or all of the foregoing items, considered alone or in any combination:

1. An apparatus for supporting a guiderail for guiding one or more articles being conveyed along a conveyor in a conveying direction, comprising:

a support rail; and

at least one adjuster for adjusting the position of the guiderail relative to the conveyor in a direction transverse to the conveying direction, the at least one adjuster comprising a collapsible support for engaging the support rail and supporting the guiderail, the at least one collapsible support adapted for being extended and retracted to selectively position the guiderail relative to the support rail.

2. The apparatus of item 1, wherein the collapsible support comprises a pair of arms connected for relative pivoting movement at one end, and each connected to a shuttle for engaging the support rail at another end.

3. The apparatus of item 2, wherein the arms are pivotably connected to a connector, the connector including a receiver adapted for receiving a portion of the guiderail.

4. The apparatus of item 3, wherein the connector includes an extension for engaging the support rail to prevent the pair of arms from reaching a locked position.

5. The apparatus of any of items 2-4, wherein each shuttle comprises a retainer for engaging the support rail.

6. The apparatus of any of items 2-5, wherein each shuttle includes at least one roller for rotatably engaging the support rail.

7. The apparatus of any of items 2-6, further including an actuator for actuating the movement of the shuttles along the support rail toward each other to extend the guiderail and away from each other to retract the guiderail.

8. The apparatus of item 7, wherein the actuator comprises a cable, and each shuttle comprises a clamp for clamping the shuttle to either a forward run of the cable or a return run of the cable.

9. The apparatus of item 8, wherein the support rail supports a pulley for guiding the cable.

10. The apparatus of item 8 or item 9, further including a motor for moving the cable to and fro along an endless path.

11. An apparatus for supporting a first guiderail for guiding one or more articles being conveyed along a conveyor in a conveying direction, comprising:

a first collapsible support for supporting the first guiderail, the first collapsible support adapted for being extended and retracted to selectively position the first guiderail; and

a first actuator for actuating the first collapsible support for extending or retracting the guiderail.

12. The apparatus of item 11, wherein the first actuator comprises a cable.

13. The apparatus of item 12, wherein the first collapsible support includes a shuttle adapted for connecting to either a forward run of the cable or a return run of the cable.

14. The apparatus of item 12 or item 13, further including a pulley for guiding the cable.

15. The apparatus of any of items 12-14, further including a motor for moving the cable to and fro in an endless path.

16. The apparatus of any of items 11-15, further including a plurality of first collapsible supports for supporting the first guiderail, and wherein the actuator is for simultaneously actuating each support for extending or retracting the first guiderail.

17. The apparatus of any of items 11-16, wherein a second guiderail is provided for guiding the one or more articles being conveyed along the conveyor in the conveying direction, and further comprising a second collapsible support for supporting the second guiderail, the second collapsible support adapted for being extended and retracted to selectively position the second guiderail relative to the first guiderail.

18. The apparatus of item 17, wherein the second collapsible support is actuated by the first actuator.

19. The apparatus of any of items 11-18, further including a second actuator for actuating the second collapsible support for extending or retracting the second guiderail independent of the first guiderail.

20. The apparatus of item 19, wherein the first actuator is adapted for actuating the first collapsible support for forming a first zone on the conveyor having a first width and the second actuator is adapted for actuating the second collapsible support for forming a second zone on the conveyor having a second width different from the first width.

21. An apparatus for supporting a guiderail for guiding one or more articles being conveyed along a conveyor in a conveying direction, comprising:

a support for supporting the guiderail, the support comprising a flexible joint.

22. The apparatus of item 21, wherein the support comprises a linkage.

23. The apparatus of item 22, wherein the linkage comprises first and second arms pivotally connected to a connector for forming the flexible joint.

24. The apparatus of item 23, wherein each of the first and second arms is adapted for translating along a support rail extending in the conveying direction.

25. The apparatus of item 22 or item 23, wherein the connector is adapted for engaging the guiderail.

26. The apparatus of any of items 21-25, further including an actuator for actuating the support to move the guiderail to and fro in a direction transverse to the conveying direction.

27. A guiderail for a conveyor, comprising a first guiderail portion having a first leg extending in a conveying direction and a second guiderail portion having a second leg extending in the conveying direction, the first and second legs being captured by at least one receiver.

28. The guiderail of item 27, wherein the first and second legs overlap in a vertical direction.

29. The apparatus of any of items 1-26 in combination with the guiderail of item 27 or item 28.

30. A method for adjusting the width of a conveying path on a conveyor having a conveying direction, comprising:

actuating a flexible support to extend and retract a guiderail in a direction transverse to the conveying direction.

31. The method of item 30, wherein the flexible support comprises first and second arms having a flexible joint at one end, and the actuating step comprises moving the first and second arms together from a greater angle to a reduced angle to cause the flexible joint to extend the guiderail.

32. The method of item 30 or item 31, wherein the flexible support comprises first and second arms having a flexible joint at one end, and the actuating step comprises moving the first and second arms apart from a reduced angle to a greater angle to cause the flexible joint to retract the guiderail.

33. The method of any of items 30-32, wherein the actuating step comprises manually causing the flexible support to expand or retract.

34. The method of any of items 30-32, wherein the actuating step comprises automatically causing the flexible support to extend or retract.

34. A method for adjusting a width of a conveying path on a conveyor having a conveying direction, comprising:

supporting a guiderail by way of a plurality of flexible supports; and

actuating a single actuator to simultaneously actuate the plurality of flexible supports to extend or retract the guiderail for controlling the width of the conveying path.

35. The method of item 34, wherein the actuating step comprises moving a cable connected to the flexible supports in an endless path.

36. The method of item 34 or item 35, wherein the flexible supports each comprise a pair of arms, each connected to a shuttle for engaging a support rail extending generally parallel to the guiderail, and wherein the actuating step comprises moving the shuttles together or apart along the support rail to extend or retract the flexible supports and hence the guiderail.

[0066] The foregoing descriptions of various embodiments of an adjustable guiderail and related methods provide illustration of the inventive concepts. The descriptions are not intended to be exhaustive or to limit the disclosed invention to the precise form disclosed. Modifications or variations are also possible in light of the above teachings. For instance, the connector forming a part of the actuator may comprise a flexible ribbon, which may be manually actuated by a lever. While the shuttles 22, 24 are shown as overlying and sliding upon the support rail 26, the shuttles could also be recessed within cavities in the support rail 26, while still functioning as shuttles. The shuttles may also take different forms, such as for example elongated flexible ribbons connected to the arms 16, 18 and designed to move along the support rail 26 or within a cavity formed therein. Any elements described herein as singular can be pluralized (i.e., anything described as “one” can be more than one), and plural elements can be used individually. Characteristics disclosed of a single variation of an element, the device, the methods, or combinations thereof can be used or apply for other variations, for example, dimensions, shapes, materials, or combinations thereof. The terms “substantially,” “about,” or

“approximately” are meant to mean as close to the corresponding condition as reasonably possible, and typically not varying from it by more than 10%, unless circumstances indicate otherwise. Any species element of a genus element can have the characteristics or elements of any other species element of that genus. The term “comprising” is not meant to be limiting. The above-described configurations, elements or complete assemblies and methods and their elements for carrying out the invention, and variations of aspects of the invention can be combined and modified with each other in any combination.

In the Claims

1. A system comprising: a guiderail for guiding one or more articles conveyed along a conveyor having a conveying path in a conveying direction, comprising:
 - a support rail; and
 - at least one adjuster for adjusting a position of the guiderail relative to the conveyor in a direction transverse to the conveying direction, the at least one adjuster comprising a collapsible support for engaging the support rail and supporting the guiderail, the collapsible support adapted for being extended and retracted into the conveying path in the direction transverse to the conveying direction to selectively position the guiderail relative to the support rail, wherein the collapsible support comprises a pair of arms connected for relative pivoting movement at one end, and each connected to a shuttle for engaging the support rail at another end, characterized in that, each shuttle includes at least one roller for rotatably engaging the support rail.
2. The system of claim 1, wherein each arm of the pair of arms is pivotably connected to a connector, the connector including a receiver adapted for receiving a portion of the guiderail.
3. The system of claim 2, wherein the connector includes an extension for engaging the support rail to prevent the pair of arms from reaching a locked position.
4. The system of claim 1, wherein each shuttle comprises a retainer for engaging the support rail and thereby holding the shuttle in the desired position.
5. The system of claim 1, further including an actuator for actuating movement of the shuttles along the support rail toward each other to extend the guiderail and away from each other to retract the guiderail.
6. The system of claim 5, wherein the actuator comprises a cable, and each shuttle comprises a clamp for clamping the shuttle to either a forward run of the cable or a return run of the cable.
7. The system of claim 6, wherein the support rail supports a pulley for guiding the cable.
8. The system of any one of claims 6 or 7, further including a motor for moving the cable to and fro along an endless path.

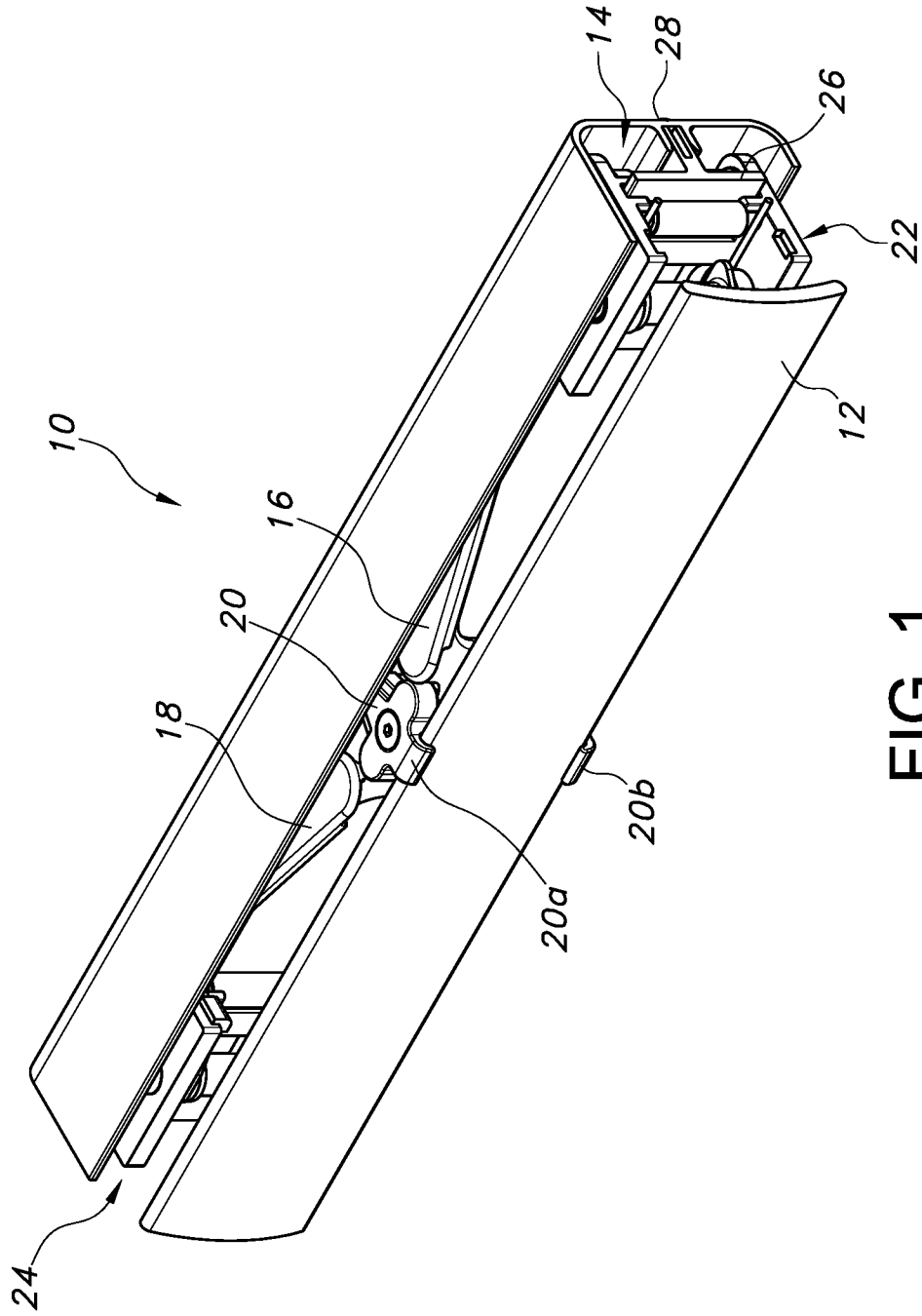

FIG. 1

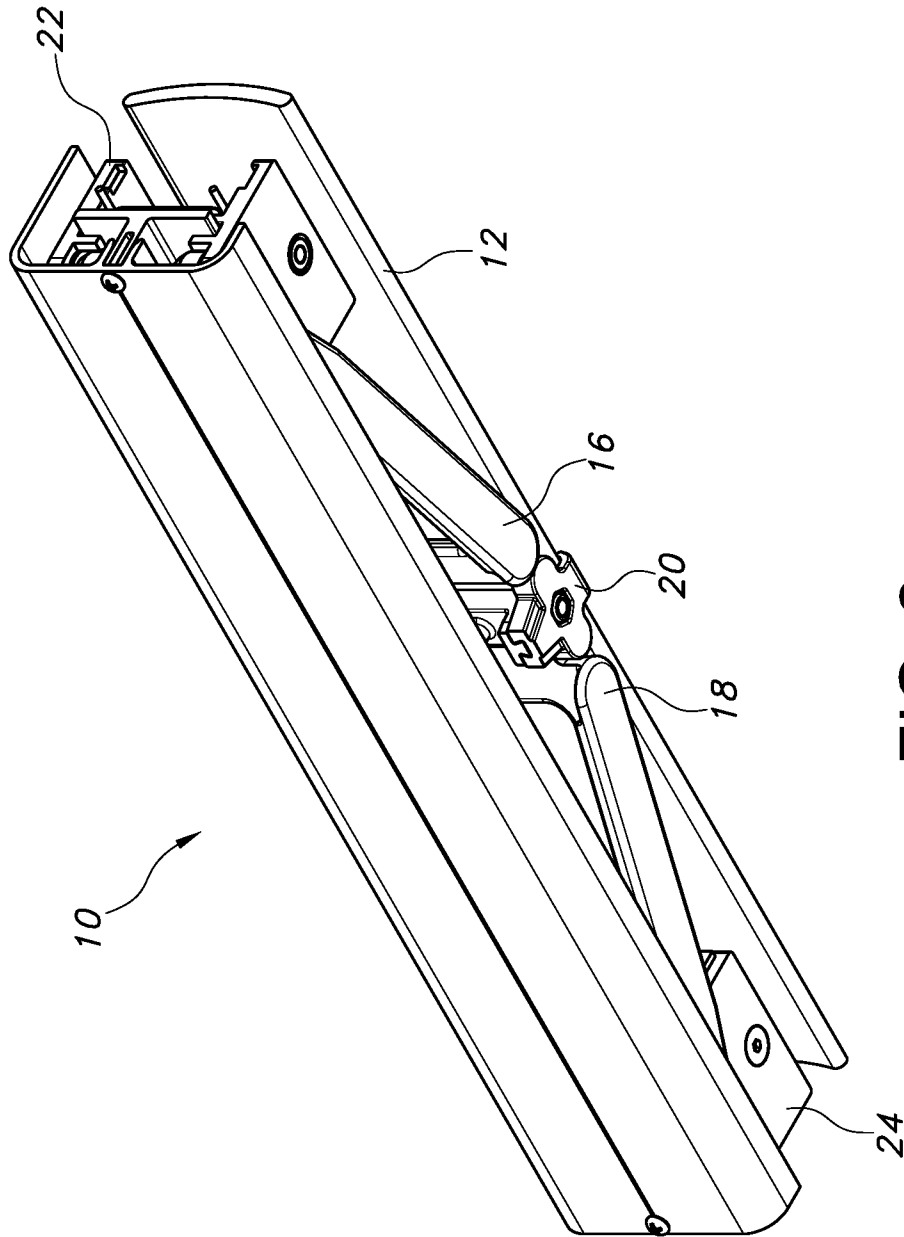

FIG. 2

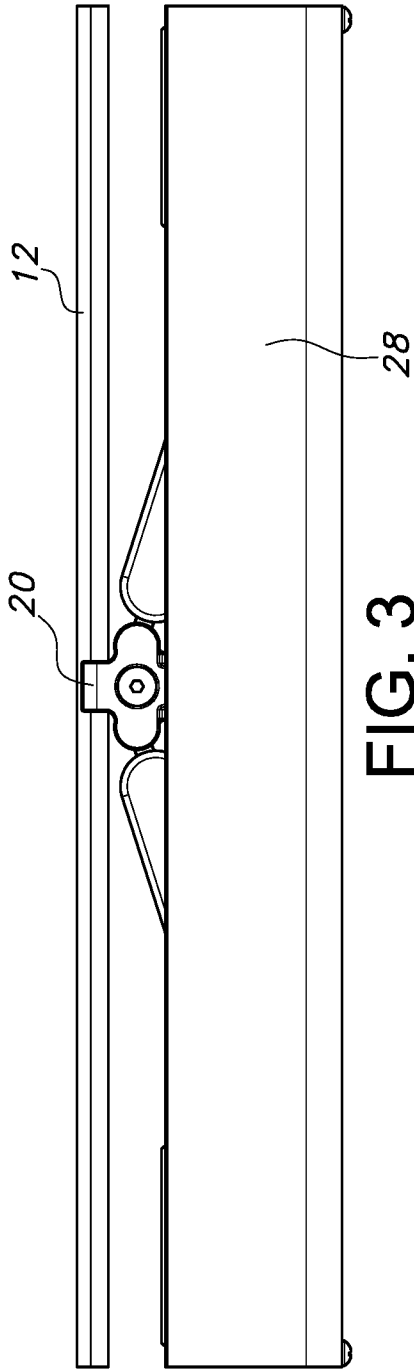
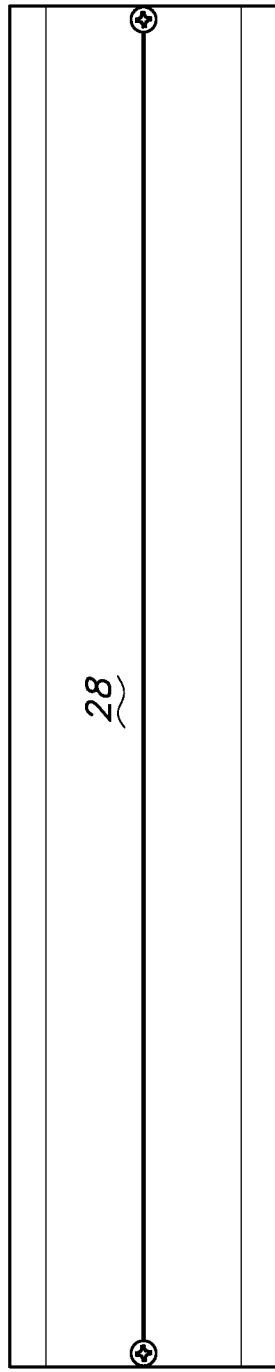

FIG. 3



28

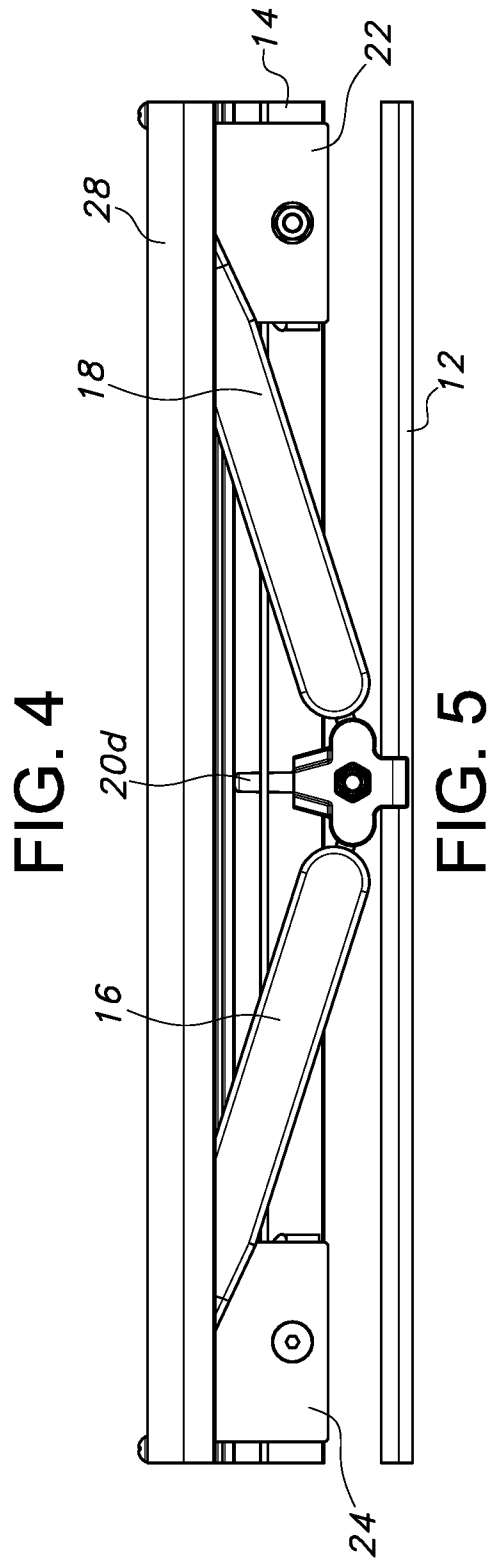

FIG. 4

FIG. 5

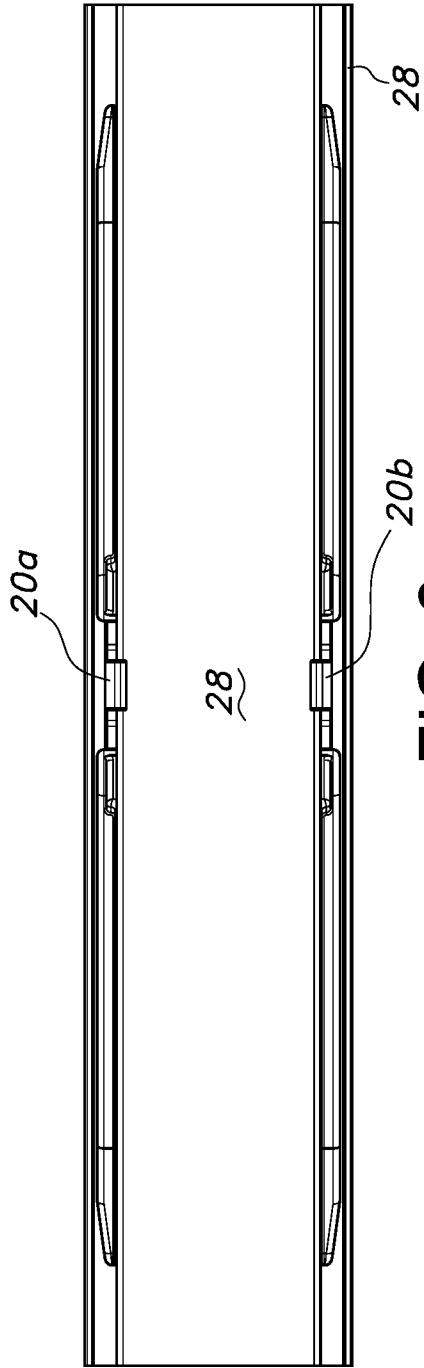

FIG. 6

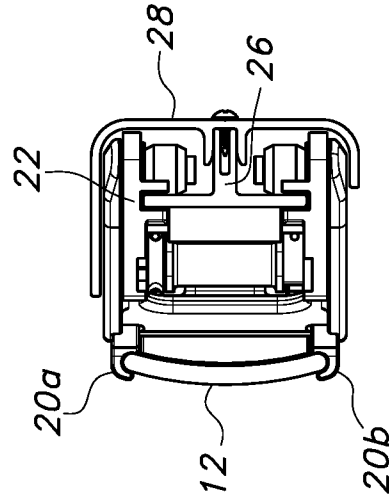

FIG. 7

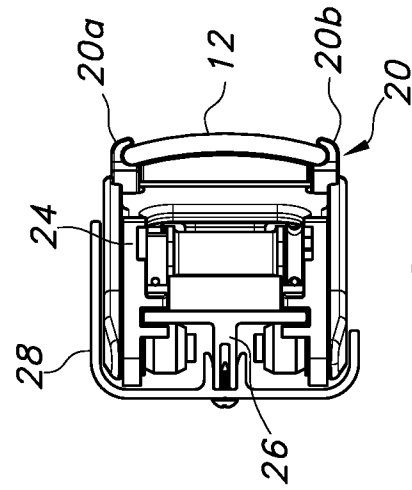

FIG. 8

5/26

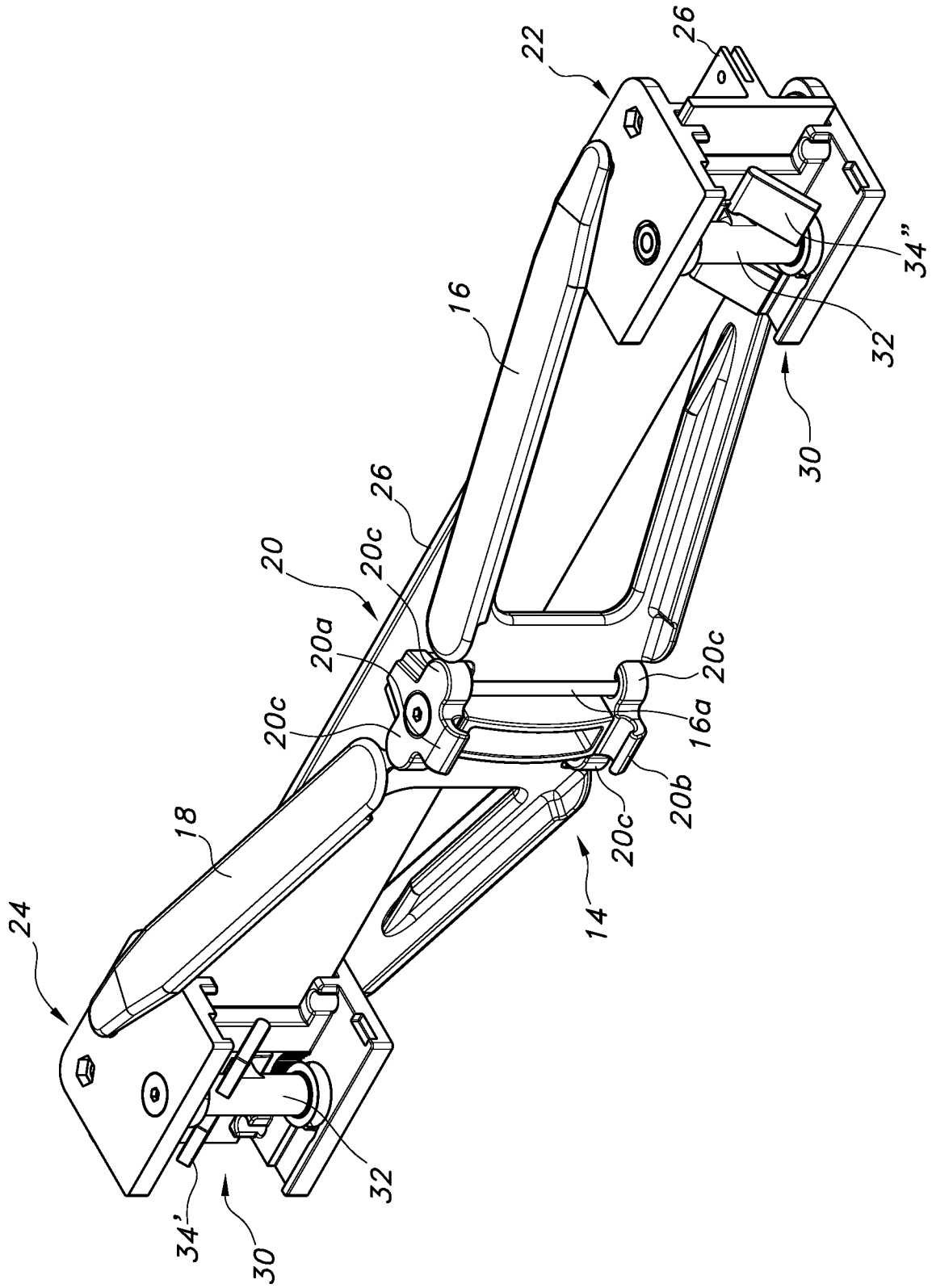

FIG. 9

6/26

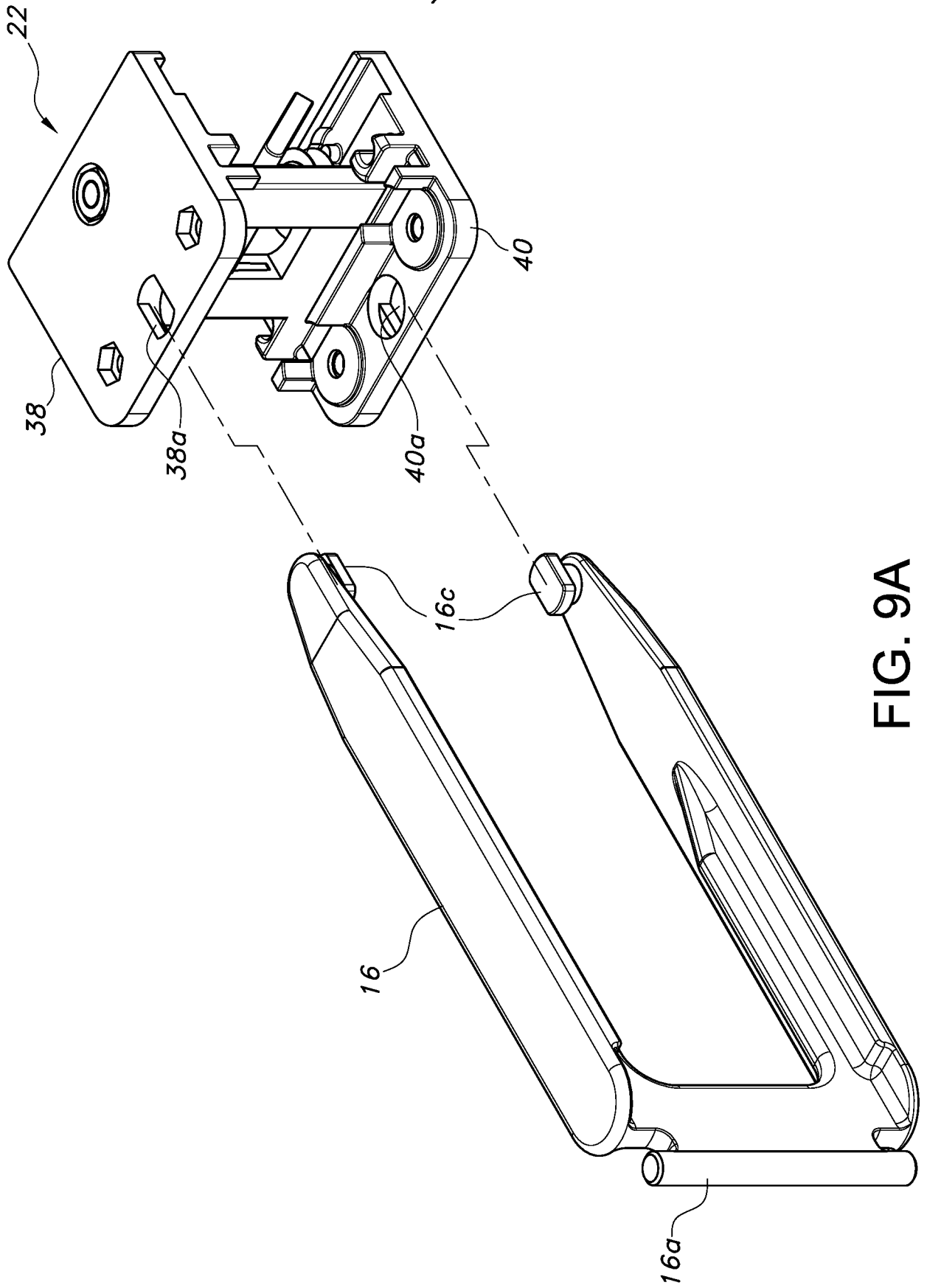

FIG. 9A

7/26

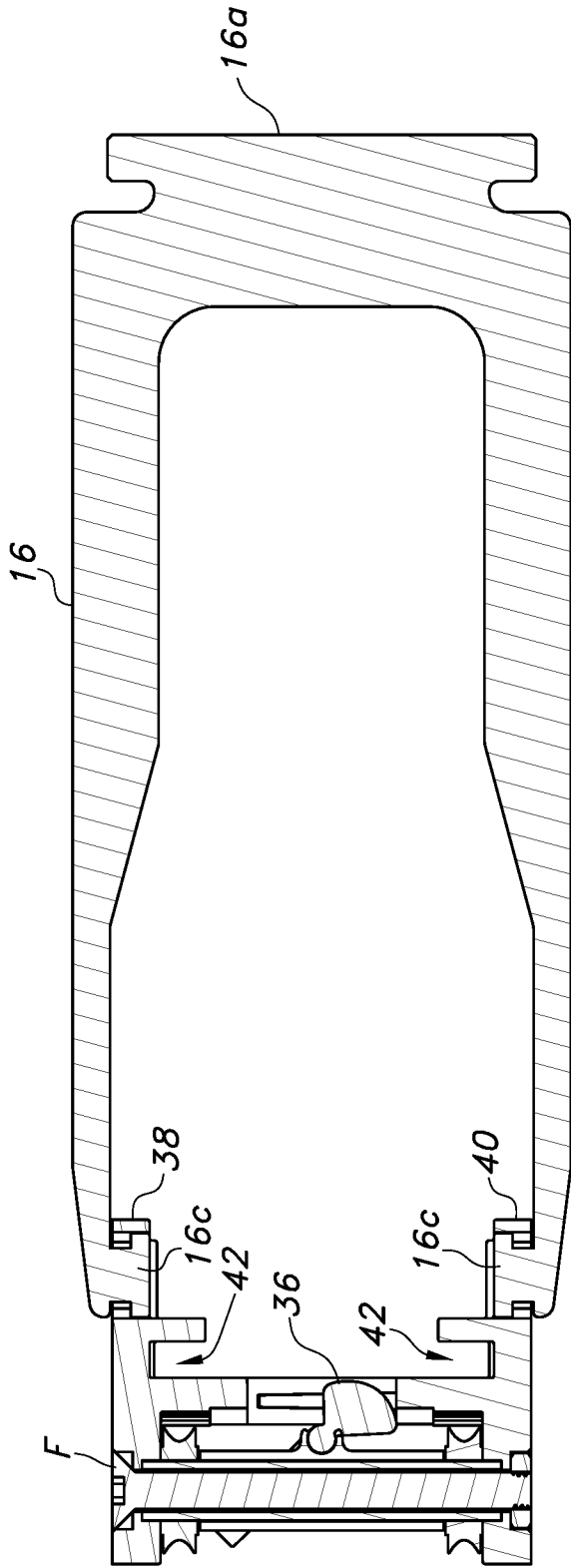

FIG. 9C

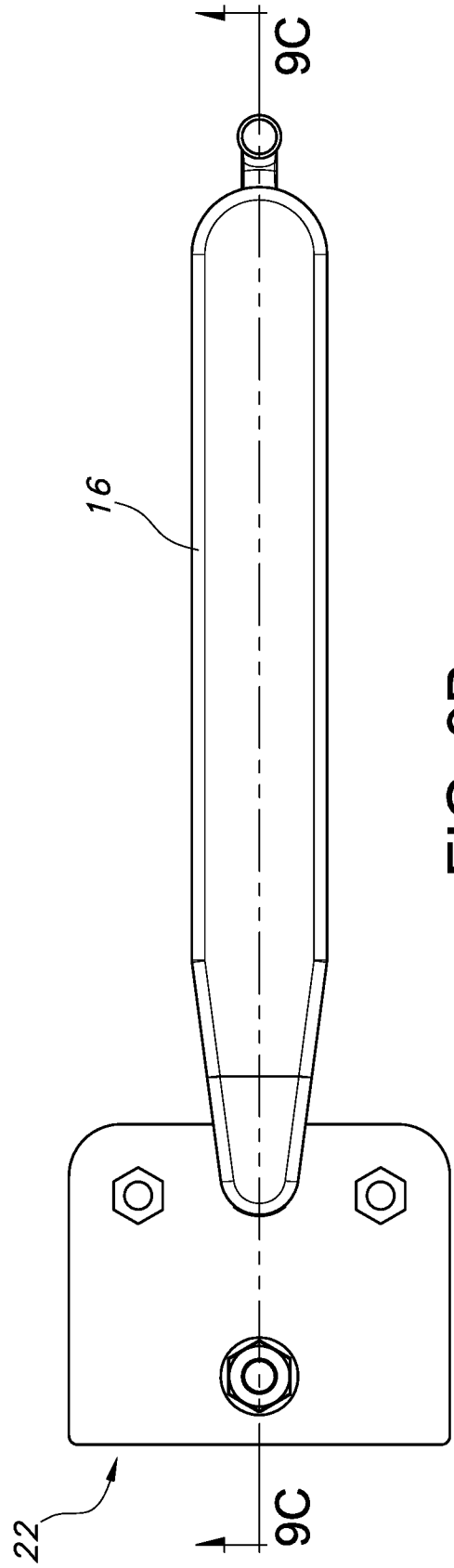

FIG. 9B

8/26

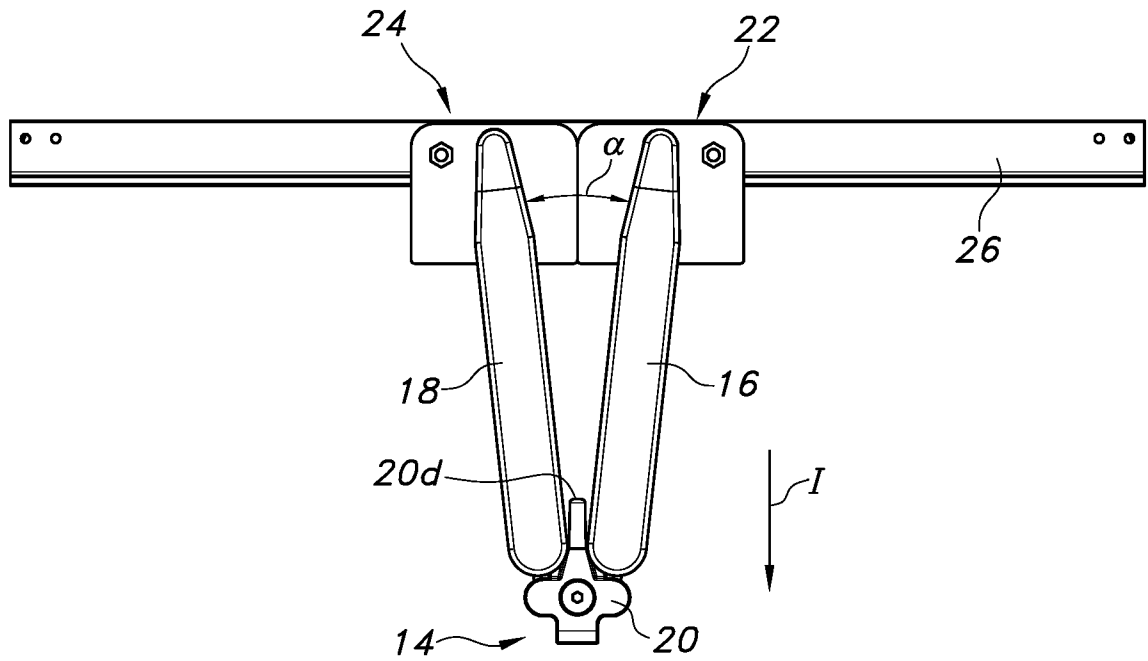

FIG. 10

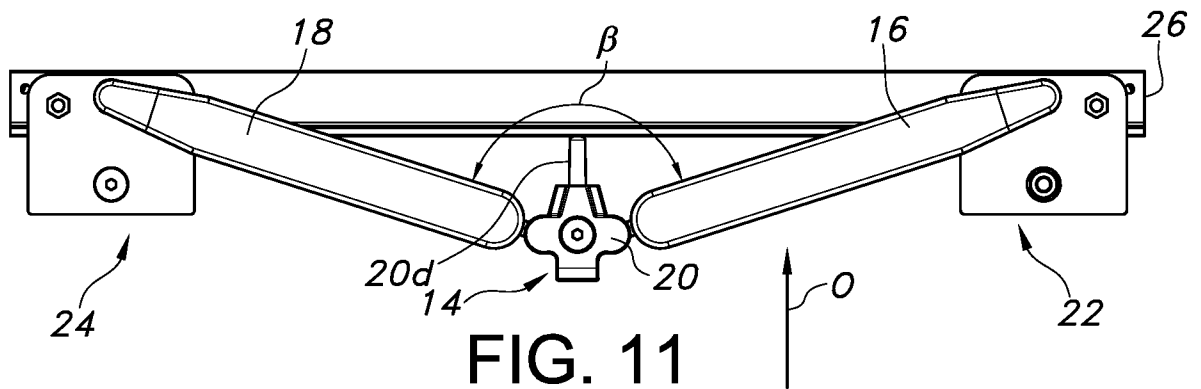

FIG. 11

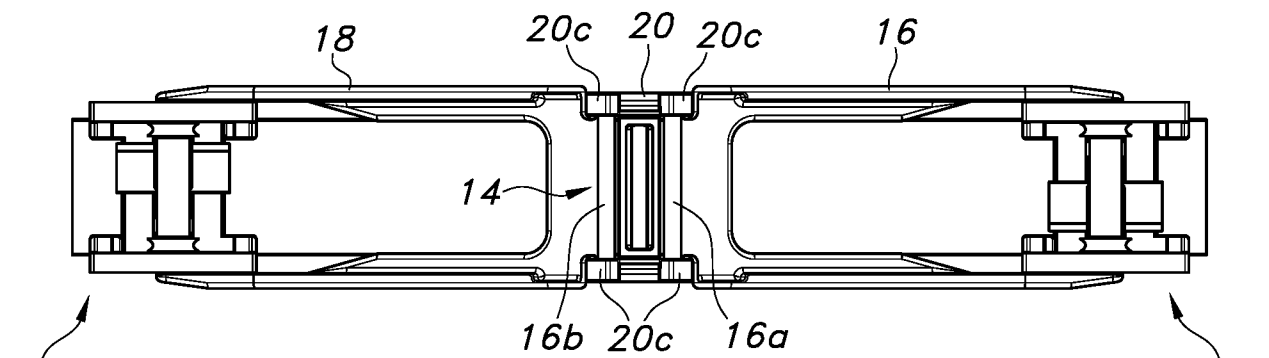

FIG. 12

9/26

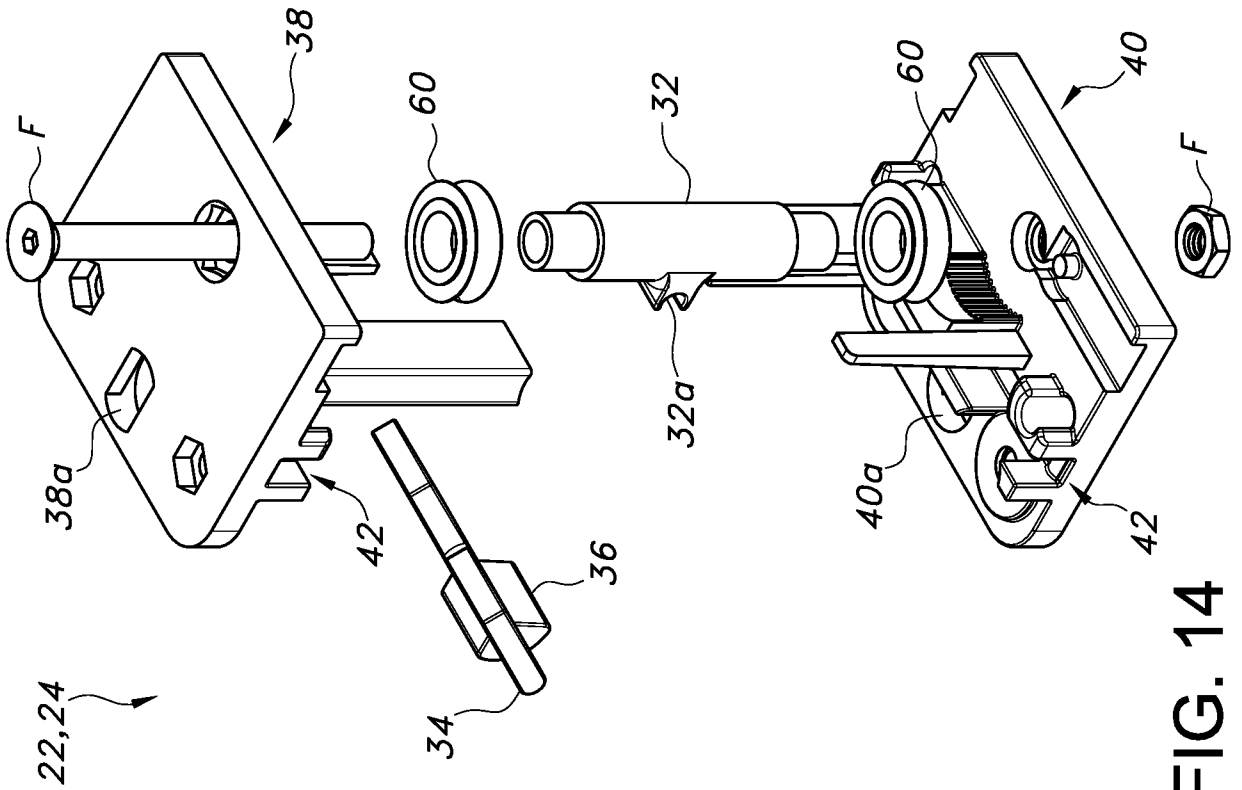

FIG. 14

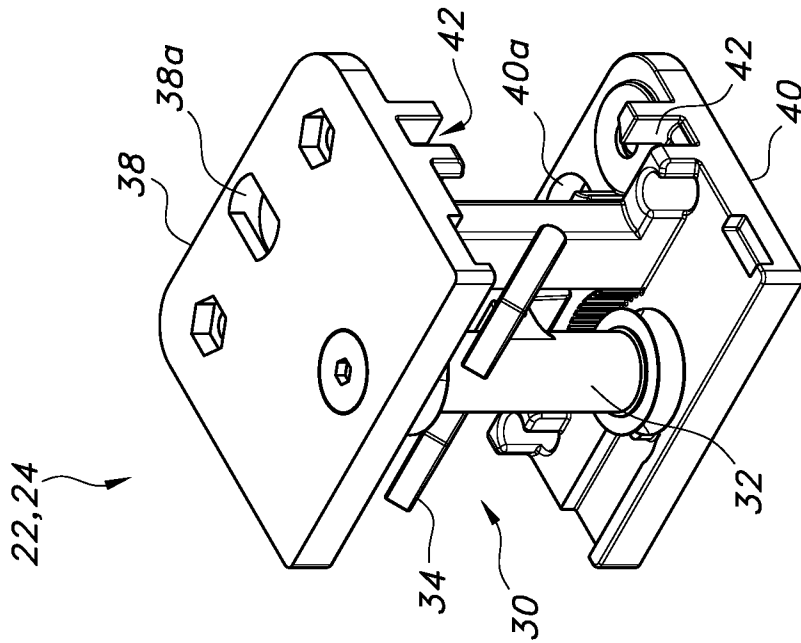

FIG. 13

11/26

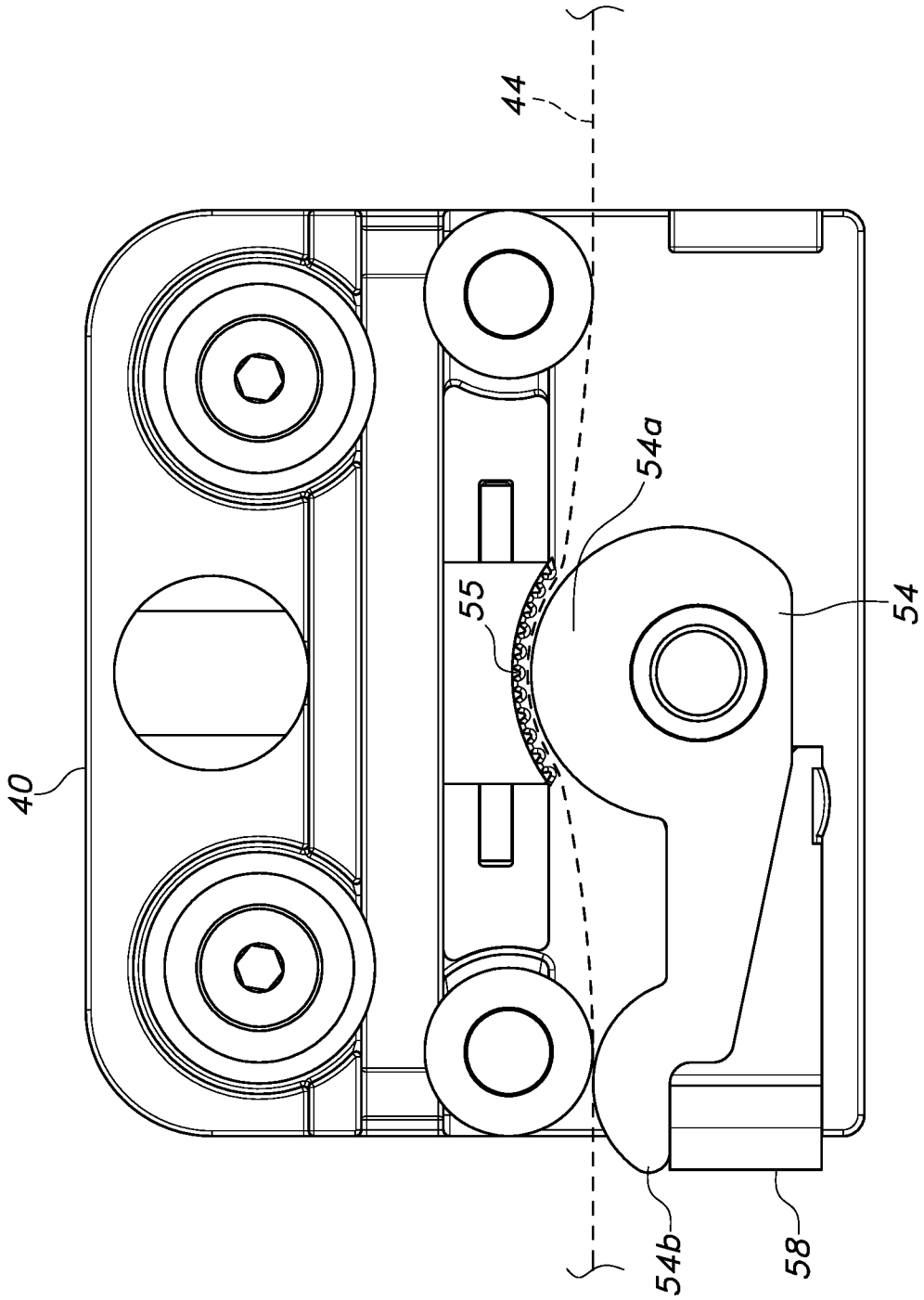

FIG. 16A

12/26

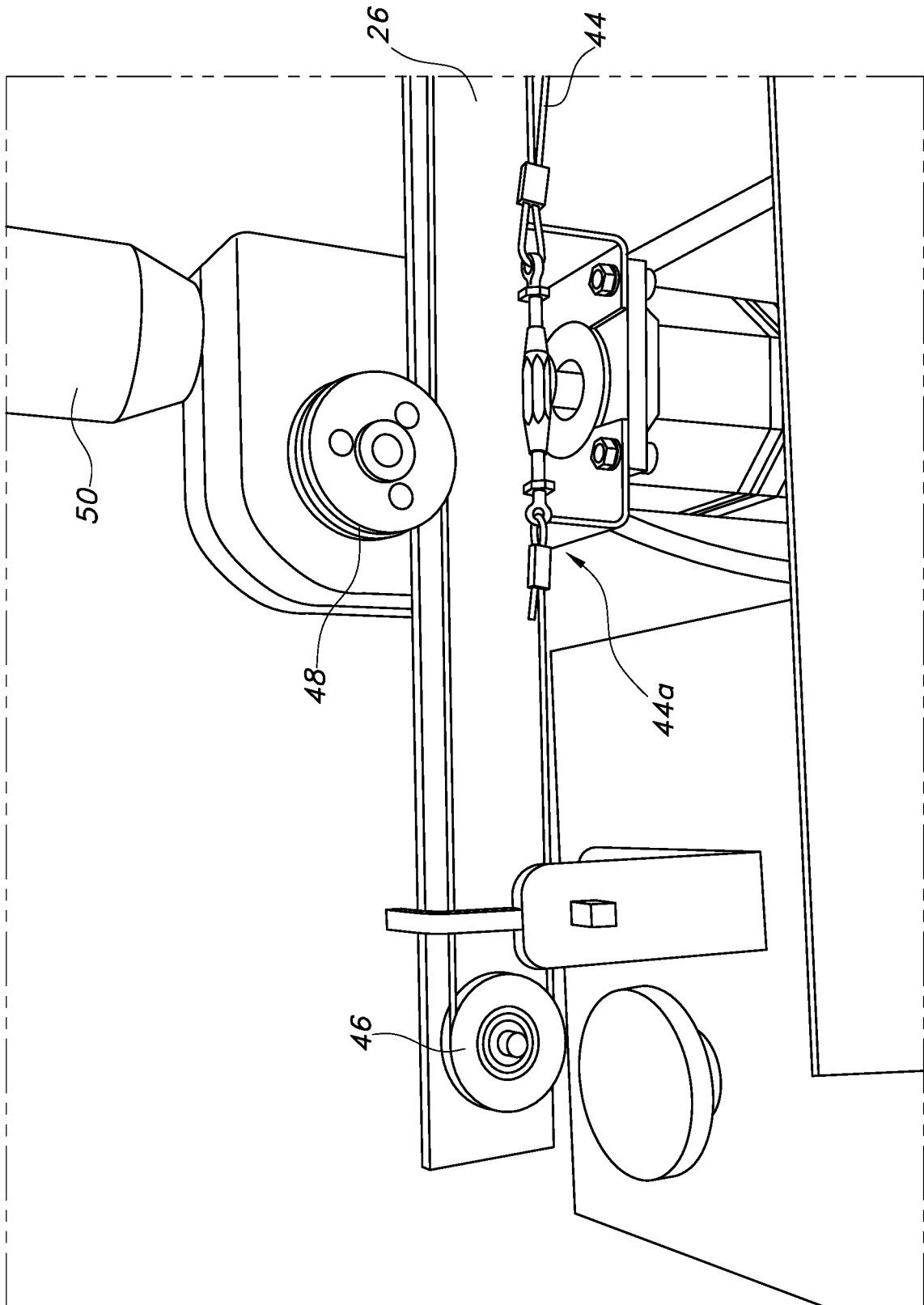

FIG. 17

13/26

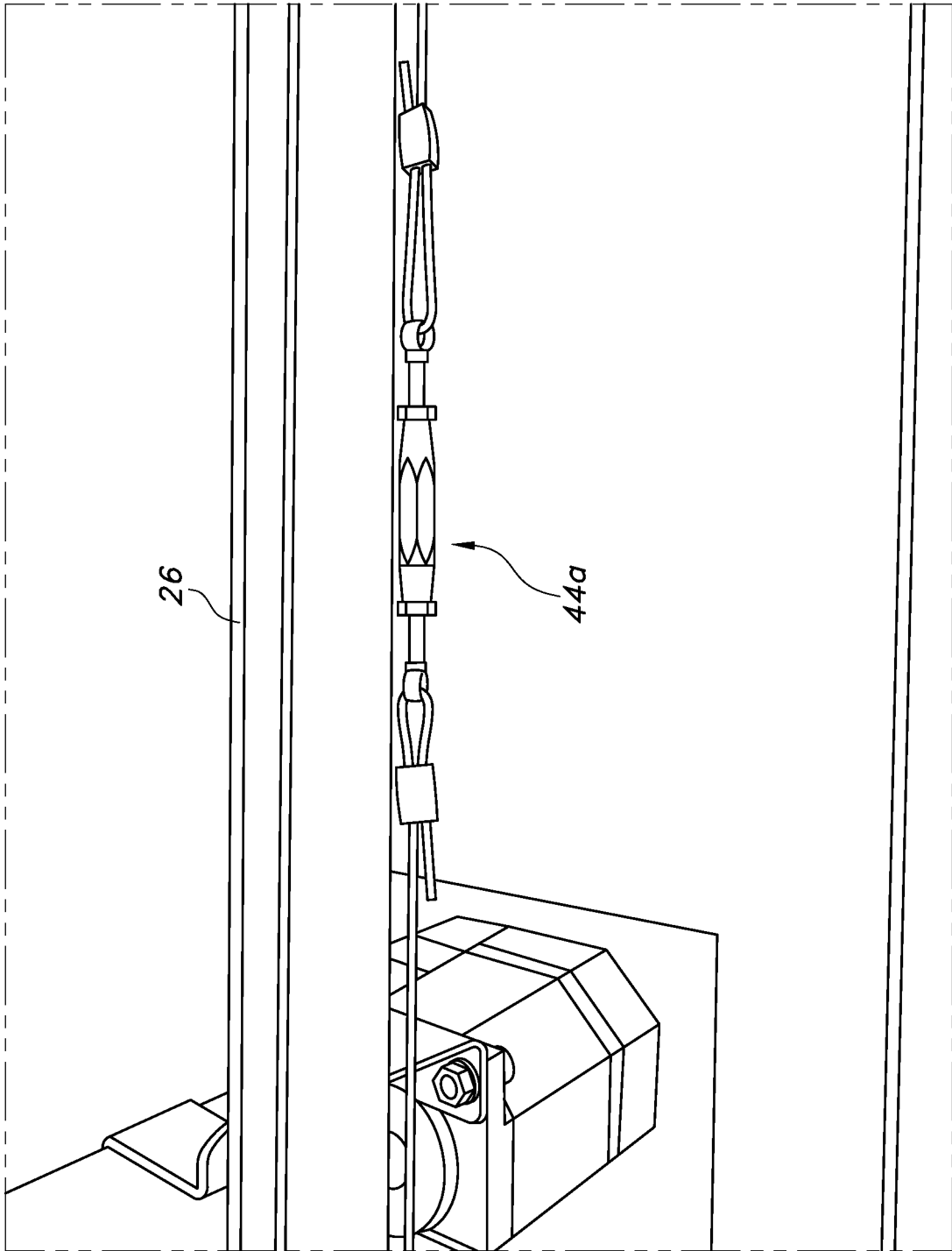

FIG. 18

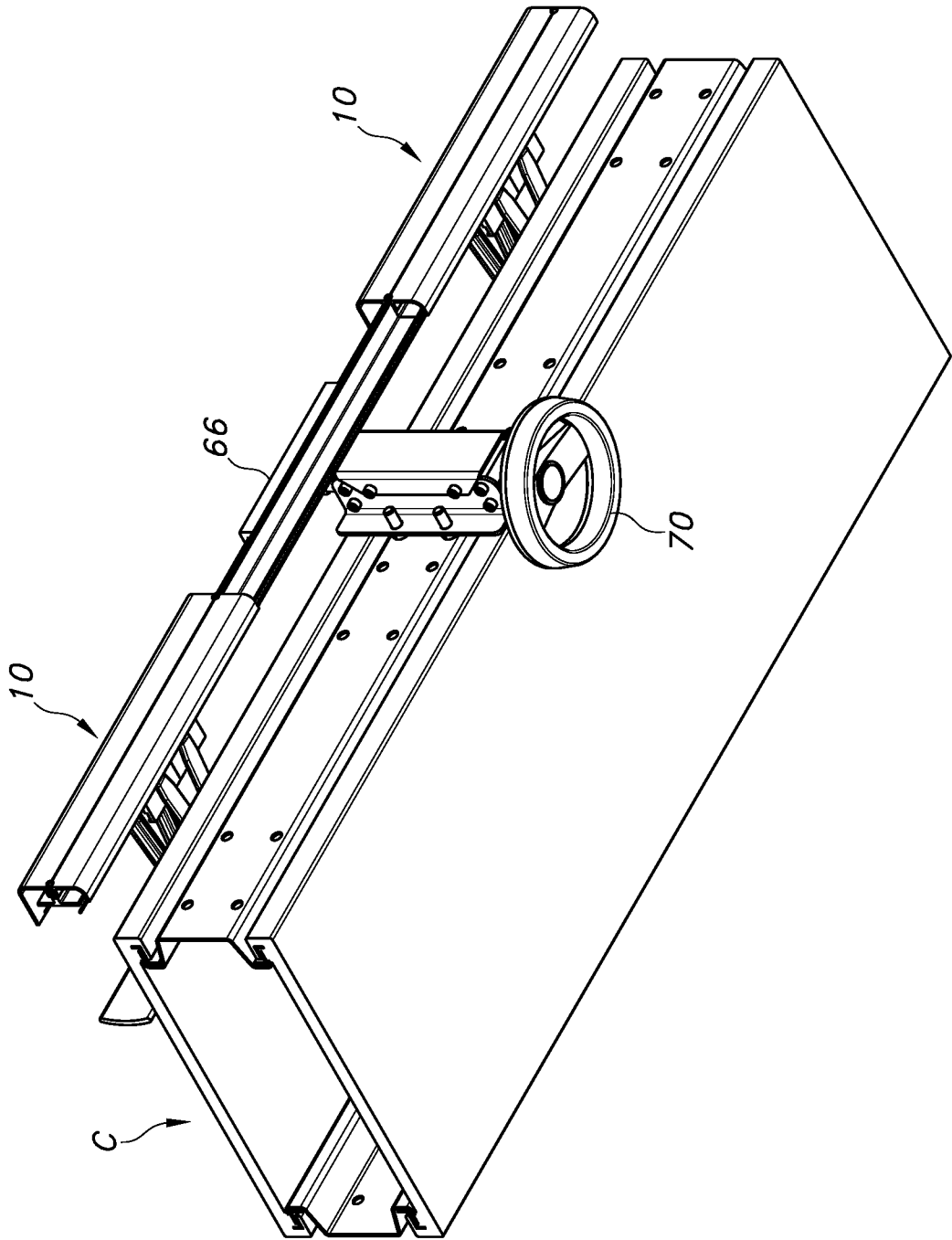

FIG. 20

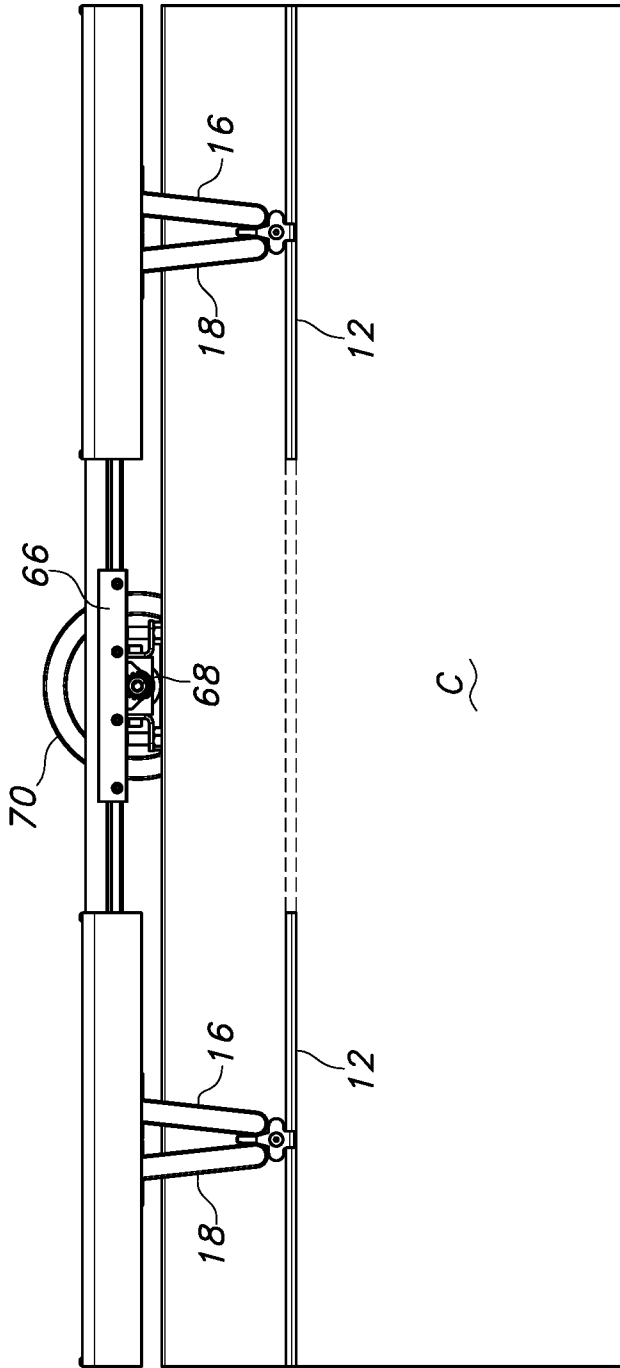

FIG. 21

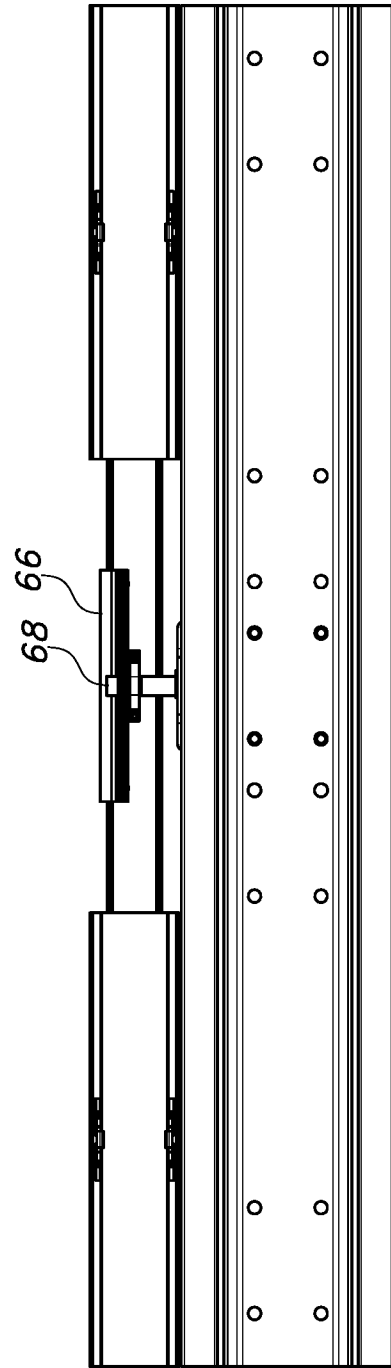

FIG. 22

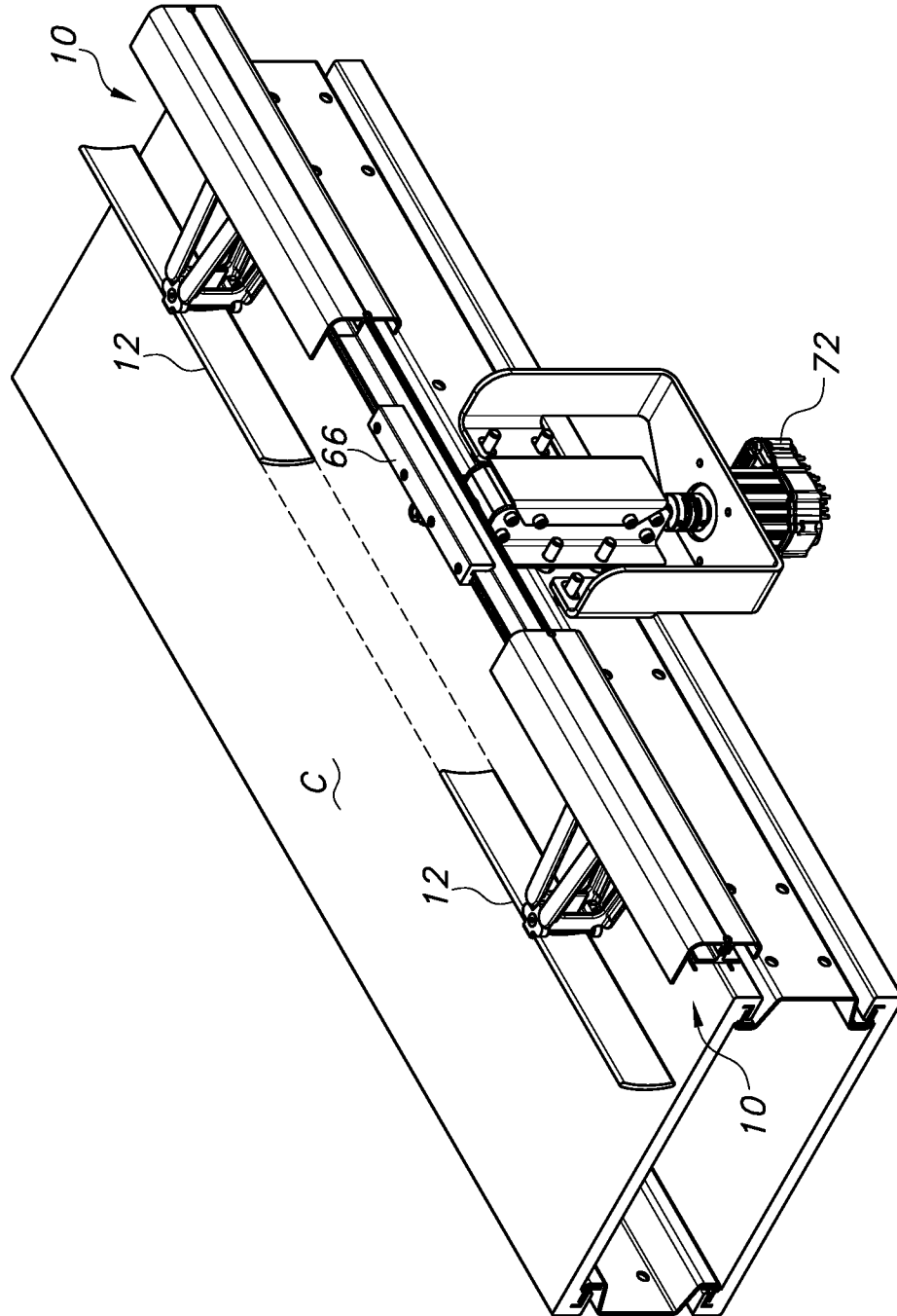

FIG. 23

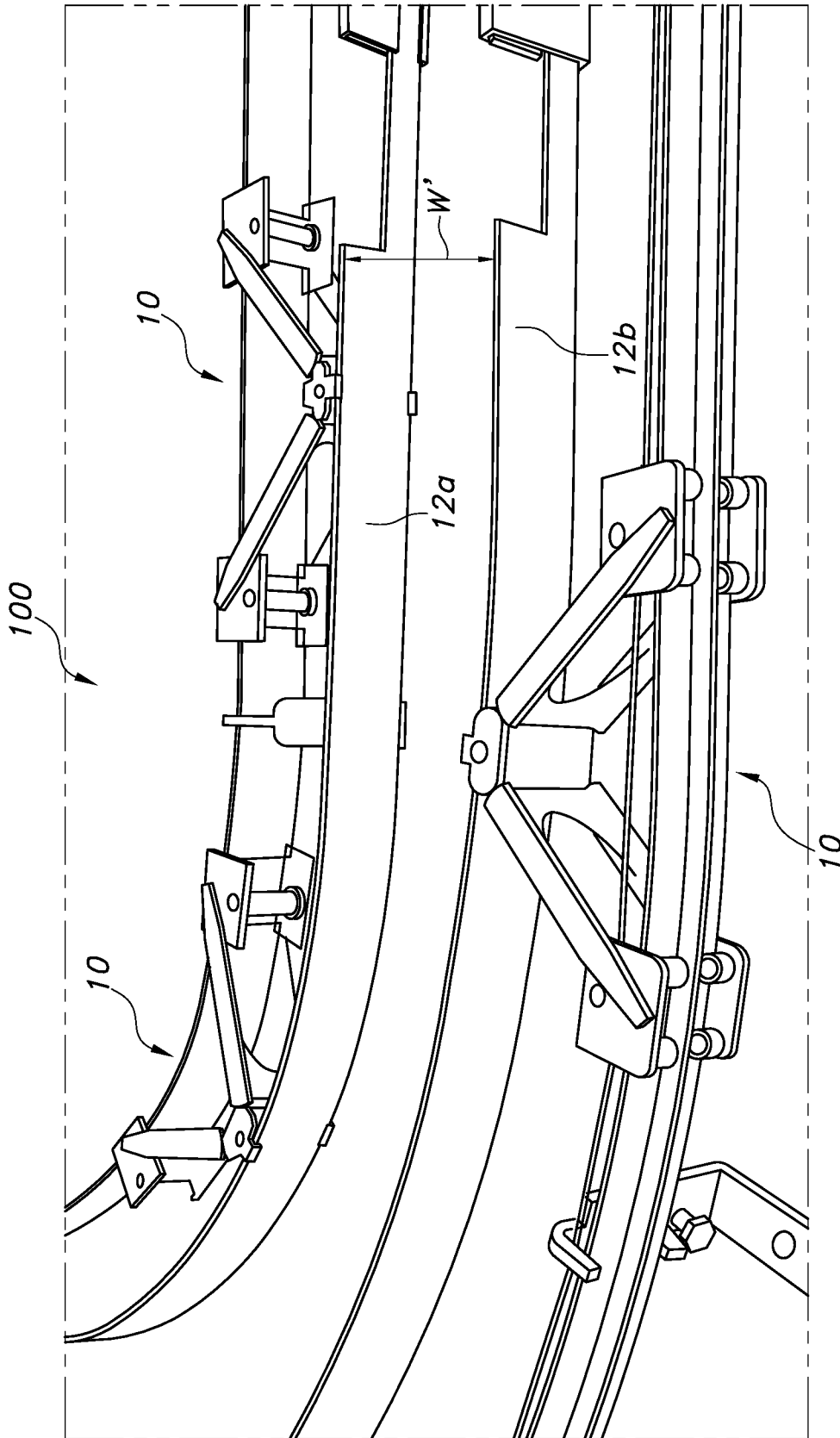
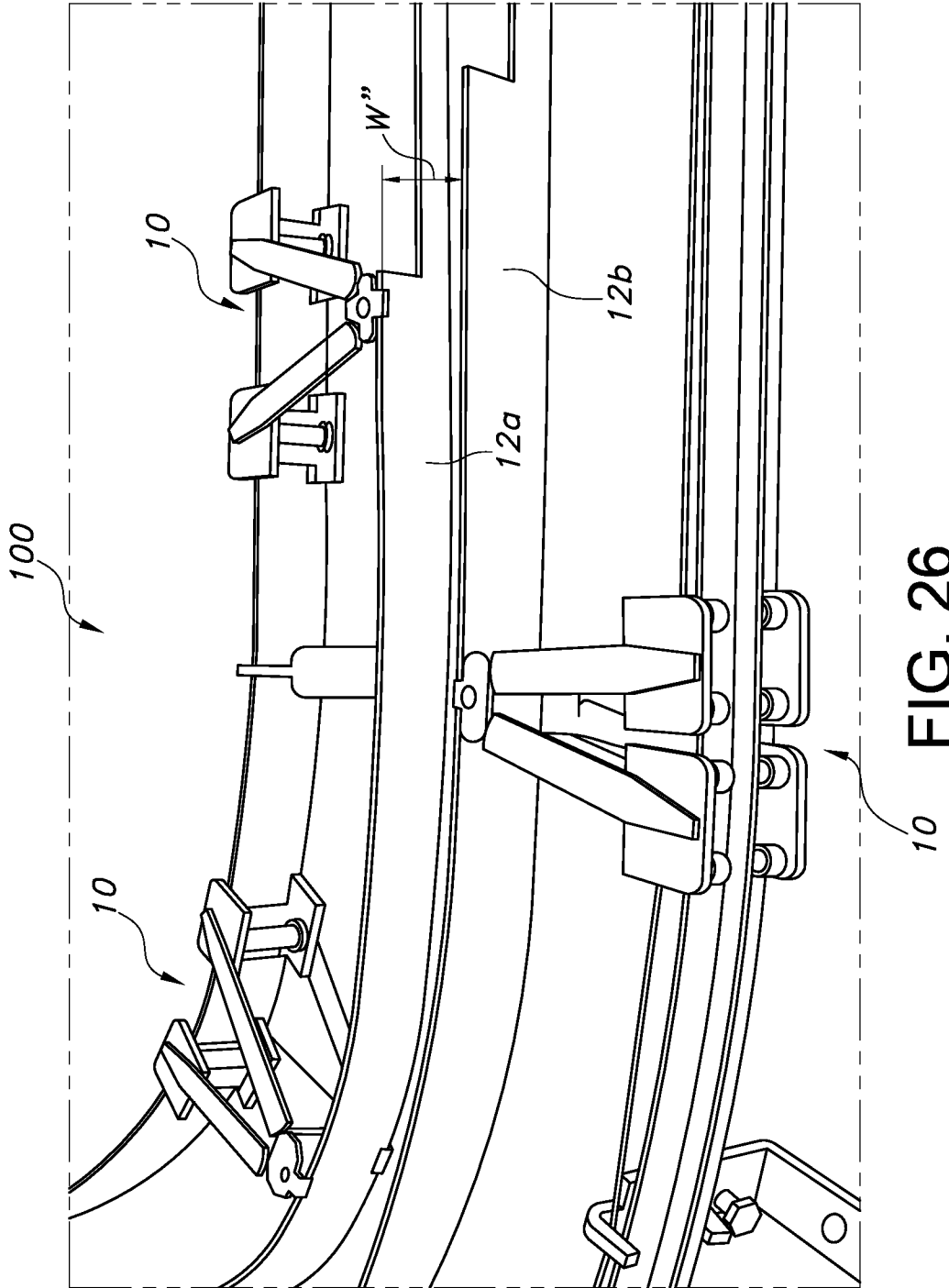

FIG. 25



10 FIG. 26

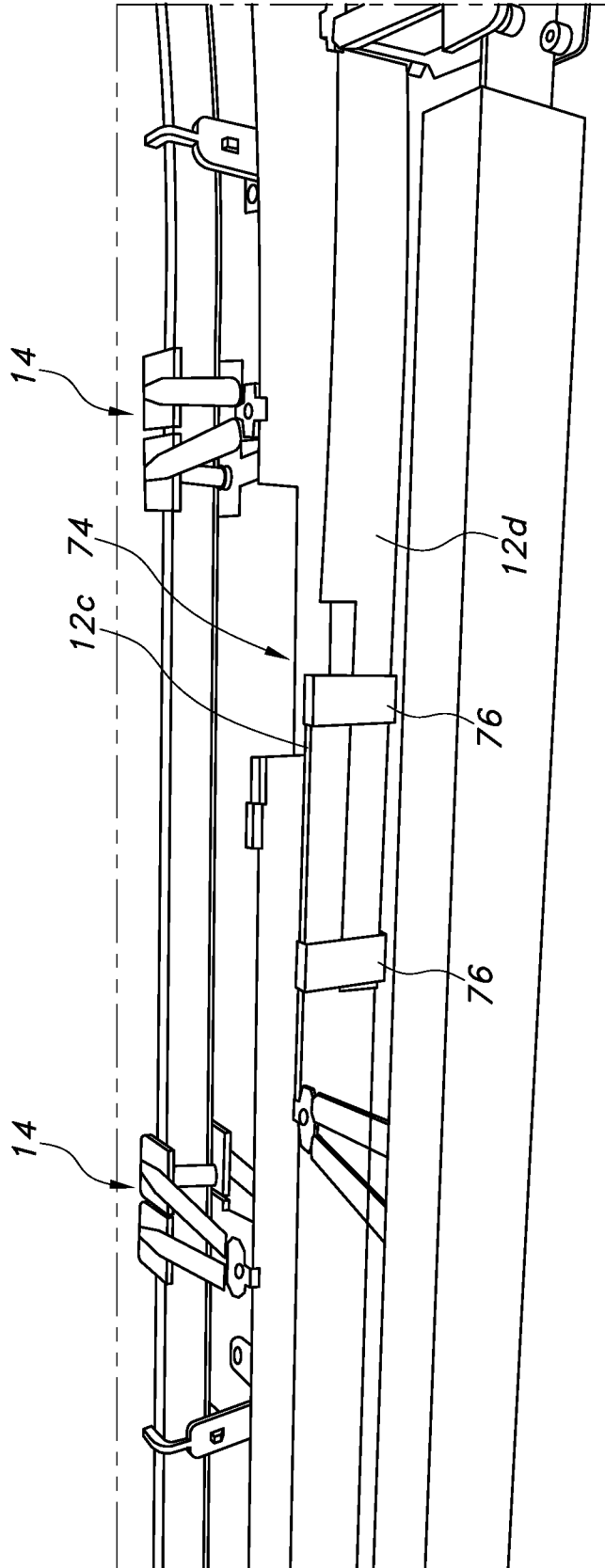

FIG. 27

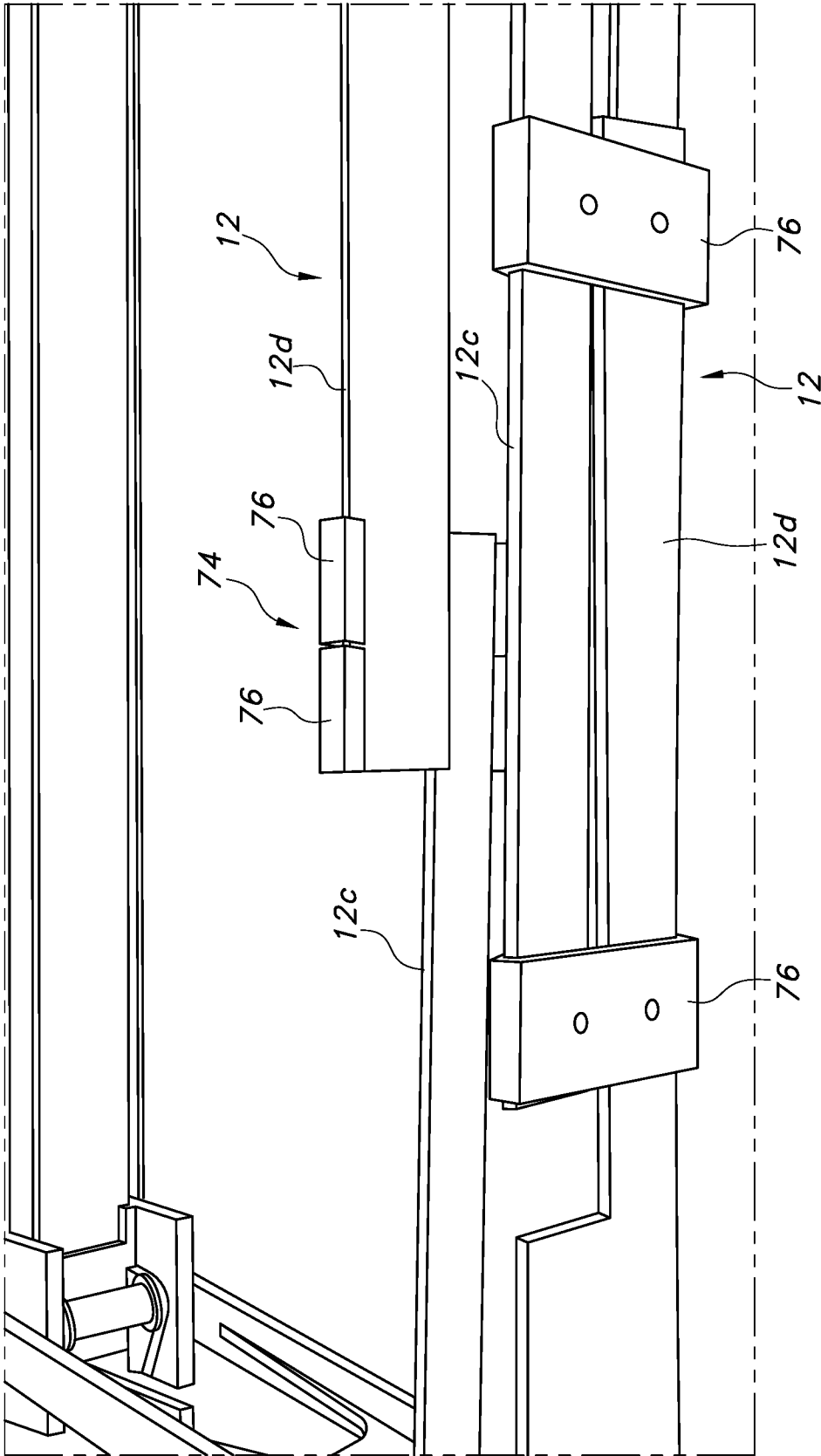

FIG. 28

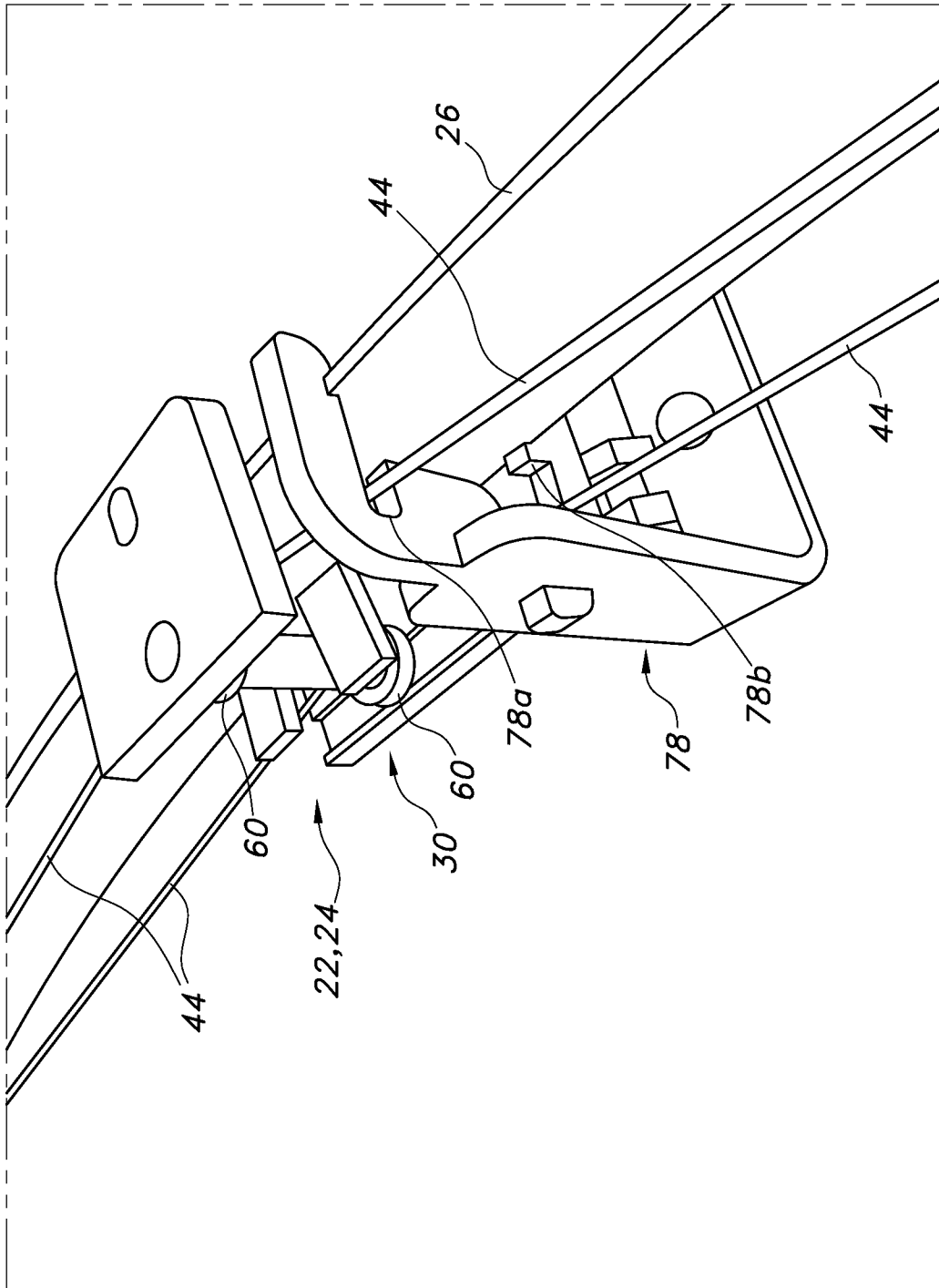

FIG. 29

24/26

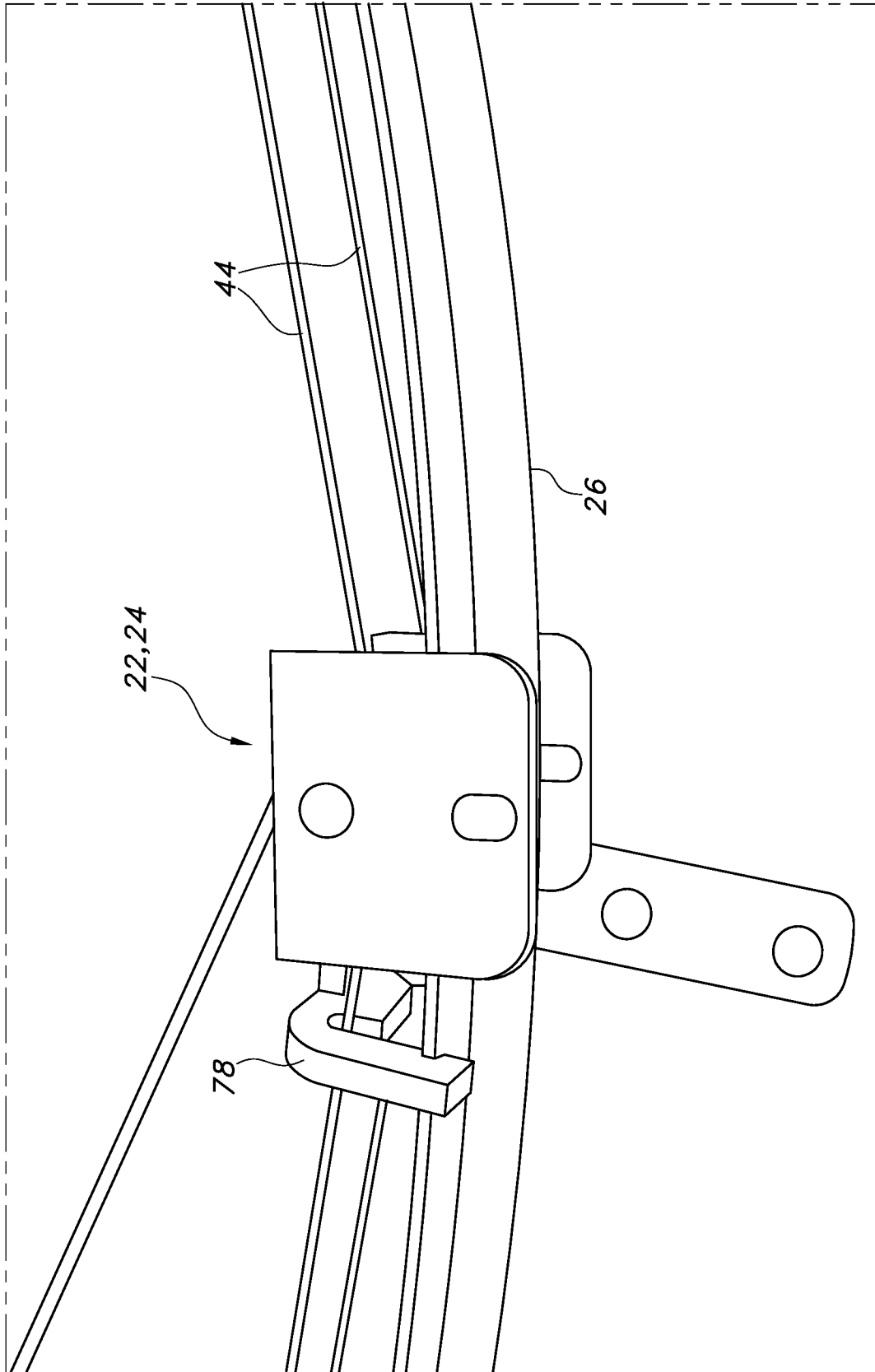

FIG. 30

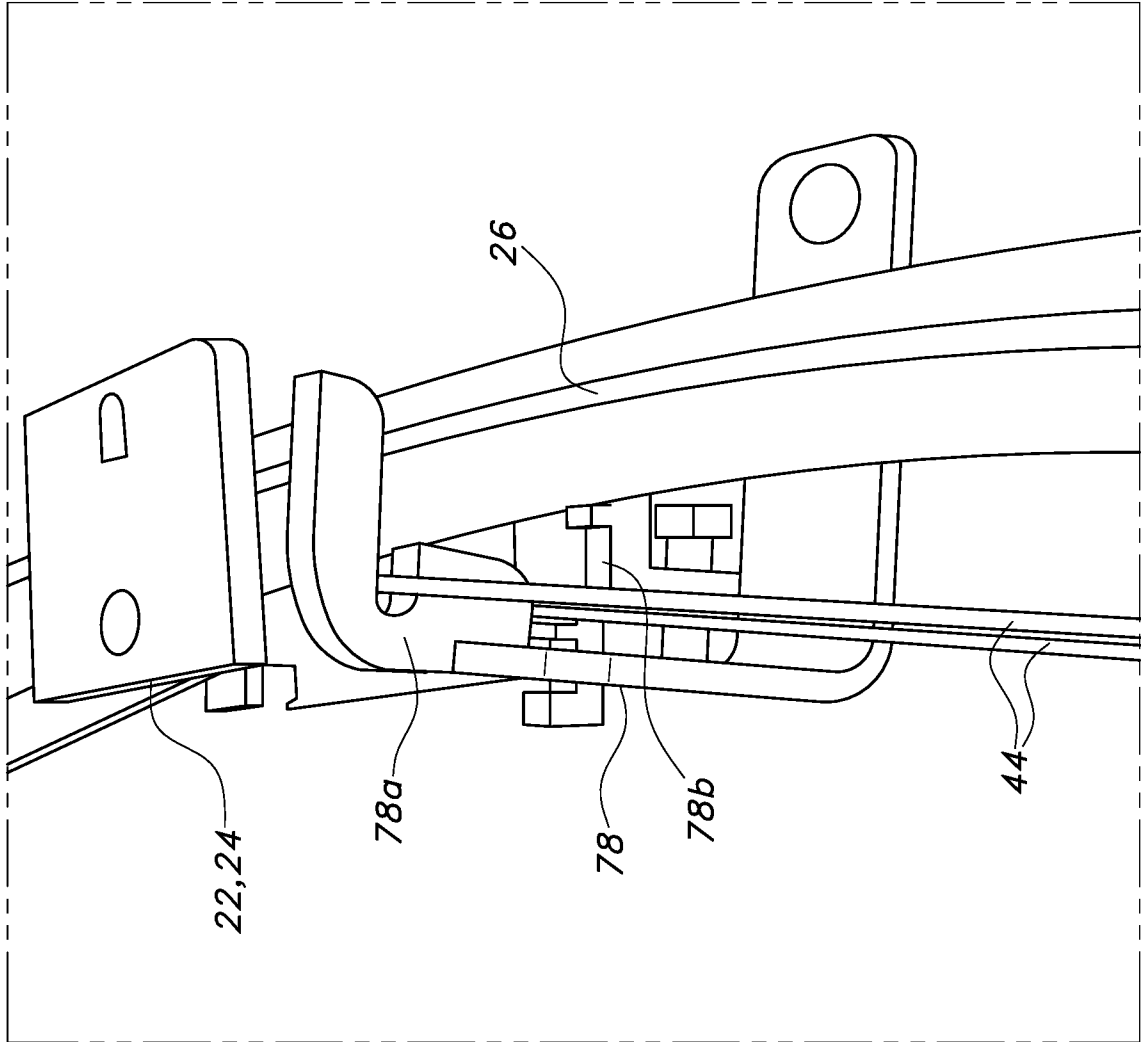

FIG. 31

26/26

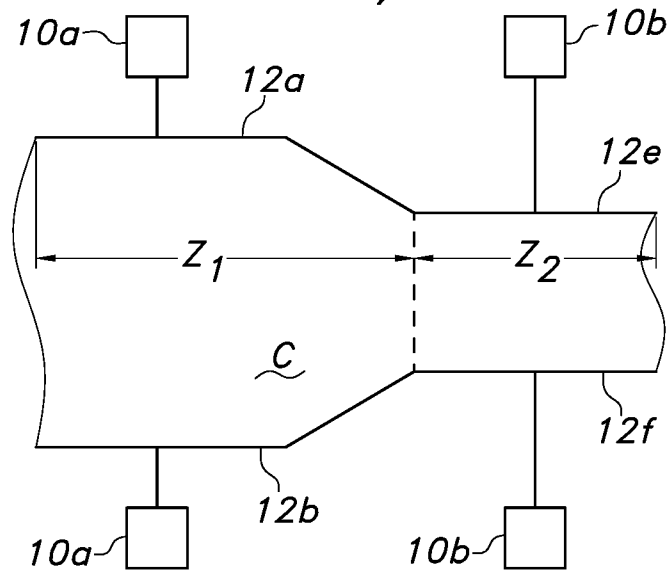

FIG. 32

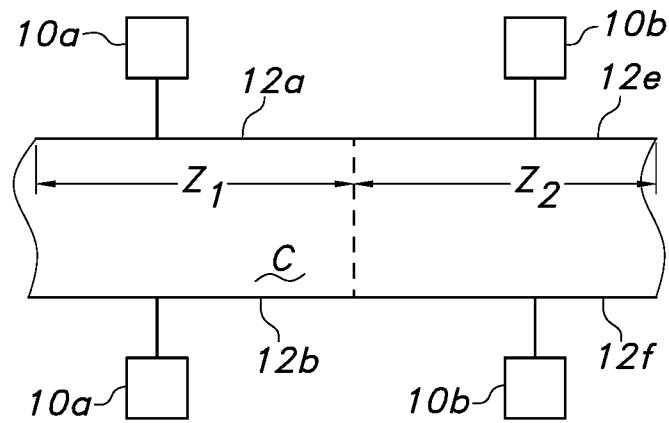

FIG. 33

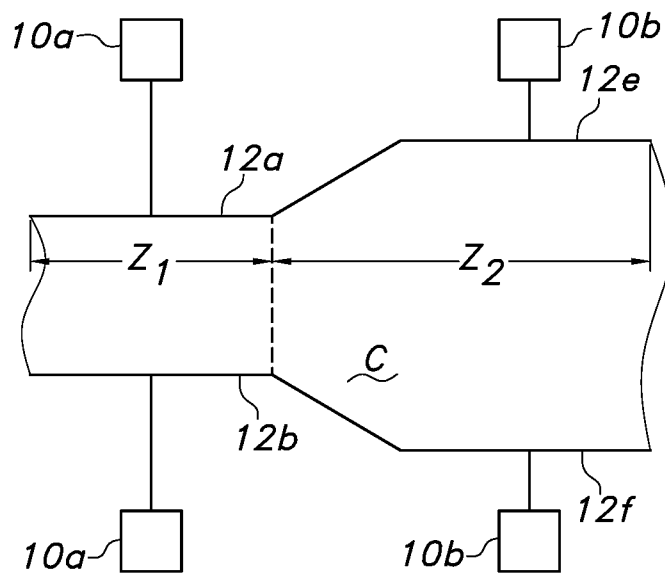

FIG. 34