

(19) World Intellectual Property Organization
International Bureau



(43) International Publication Date
13 November 2003 (13.11.2003)

PCT

(10) International Publication Number
WO 03/094028 A1

- (51) International Patent Classification⁷: G06F 15/173
- (21) International Application Number: PCT/US03/13144
- (22) International Filing Date: 28 April 2003 (28.04.2003)
- (25) Filing Language: English
- (26) Publication Language: English
- (30) Priority Data:
10/134,948 29 April 2002 (29.04.2002) US
- (71) Applicant: HARRIS CORPORATION [US/US]; 1025 W. NASA Blvd., Melbourne, FL 32919 (US).
- (72) Inventor: BILLHARTZ, Tom; 2355 Polonius Lane, Melbourne, FL 32934 (US).
- (74) Agents: YATSKO, Micheal, S. et al.; Harris Corporation, 1025 W. NASA Blvd., Melbourne, FL 32919 (US).
- (81) Designated States (national): AE, AG, AL, AM, AT, AU, AZ, BA, BB, BG, BR, BY, BZ, CA, CH, CN, CO, CR, CU,

CZ, DE, DK, DM, DZ, EC, EE, ES, FI, GB, GD, GE, GH, GM, HR, HU, ID, IL, IN, IS, JP, KE, KG, KP, KR, KZ, LC, LK, LR, LS, LT, LU, LV, MA, MD, MG, MK, MN, MW, MX, MZ, NO, NZ, OM, PH, PL, PT, RO, RU, SD, SE, SG, SK, SL, TJ, TM, TN, TR, TT, TZ, UA, UG, UZ, VN, YU, ZA, ZM, ZW.

(84) Designated States (regional): ARIPO patent (GH, GM, KE, LS, MW, MZ, SD, SL, SZ, TZ, UG, ZM, ZW), Eurasian patent (AM, AZ, BY, KG, KZ, MD, RU, TJ, TM), European patent (AT, BE, BG, CH, CY, CZ, DE, DK, EE, ES, FI, FR, GB, GR, HU, IE, IT, LU, MC, NL, PT, RO, SE, SI, SK, TR), OAPI patent (BF, BJ, CF, CG, CI, CM, GA, GN, GQ, GW, ML, MR, NE, SN, TD, TG).

Published:
— with international search report

For two-letter codes and other abbreviations, refer to the "Guidance Notes on Codes and Abbreviations" appearing at the beginning of each regular issue of the PCT Gazette.

(54) Title: TRACKING TRAFFIC IN A MOBILE AD HOC NETWORK

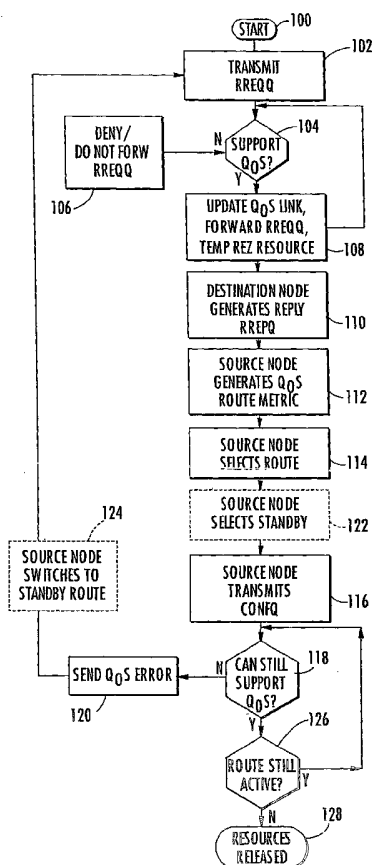

(57) Abstract: A mobile ad hoc network includes a plurality of wireless mobile nodes and a plurality of wireless communication links connecting the plurality of nodes together. The method of tracking traffic includes each node monitoring traffic communicated between nodes in the network, each node generating traffic information (112,114) based upon how much traffic is being communicated between various nodes in the network, and each node storing the traffic information in a traffic database. The traffic information may be based upon bandwidth and may include at least one of error rate, end-to-end delay, end-to-end delay variation, hop count, expected path durability, and priority. Each node may discover and select traffic routes based upon the stored traffic information.

WO 03/094028 A1

TRACKING TRAFFIC IN A MOBILE AD HOC NETWORK**Field of the Invention**

The present invention relates to the field of communication networks, and, more particularly, to mobile ad hoc wireless networks and related methods.

Background of the Invention

5 Wireless networks have experienced increased development in the past decade. One of the most rapidly developing areas is mobile ad hoc networks. Physically, a mobile ad hoc network includes a number of geographically-distributed, potentially mobile nodes sharing a common radio
10 channel. Compared with other type of networks, such as cellular networks or satellite networks, the most distinctive feature of mobile ad hoc networks is the lack of any fixed infrastructure. The network is formed of mobile nodes only, and a network is created on the fly as the nodes transmit with
15 each other. The network does not depend on a particular node and dynamically adjusts as some nodes join or others leave the network.

 In a hostile environment where a fixed communication infrastructure is unreliable or unavailable, such as in a
20 battle field or in a natural disaster area struck by earthquake or hurricane, an ad hoc network can be quickly deployed and provide limited but much needed communications. While the military is still a major driving force behind the development of these networks, ad hoc networks are quickly
25 finding new applications in civilian or commercial areas. Ad hoc networks will allow people to exchange data in the field or in a class room without using any network structure except the one they create by simply turning on their computers or PDAs.

As wireless communication increasingly permeates everyday life, new applications for mobile ad hoc networks will continue to emerge and become an important part of the communication structure. Mobile ad hoc networks pose serious
5 challenges to the designers. Due to the lack of a fixed infrastructure, nodes must self-organize and reconfigure as they move, join or leave the network. All nodes are essentially the same and there is no natural hierarchy or central controller in the network. All functions have to be
10 distributed among the nodes. Nodes are often powered by batteries and have limited communication and computation capabilities. The bandwidth of the system is usually limited. The distance between two nodes often exceeds the radio transmission range, and a transmission has to be relayed by
15 other nodes before reaching its destination. Consequently, a network has a multihop topology, and this topology changes as the nodes move around.

The Mobile Ad-Hoc Networks (MANET) working group of the Internet Engineering Task Force (IETF) has been actively
20 evaluating and standardizing routing, including multicasting, protocols. Because the network topology changes arbitrarily as the nodes move, information is subject to becoming obsolete, and different nodes often have different views of the network, both in time (information may be outdated at some nodes but
25 current at others) and in space (a node may only know the network topology in its neighborhood and not far away from itself).

A routing protocol needs to adapt to frequent topology changes and with less accurate information. Because
30 of these unique requirements, routing in these networks are very different from others. Gathering fresh information about the entire network is often costly and impractical. Many routing protocols are reactive (on-demand) protocols: they collect routing information only when necessary and to

destinations they need routes to, and do not maintain unused routes. This way the routing overhead is greatly reduced compared to pro-active protocols which maintain optimal routes to all destinations at all time. This is important for a
5 protocol to be adaptive. Ad Hoc on Demand Distance Vector (AODV), Dynamic Source Routing (DSR) and Temporally Ordered Routing Algorithm (TORA) are representatives of on-demand routing protocols presented at the MANET working group.

Examples of other various routing protocols include
10 Destination Sequenced Distance-Vector (DSDV) routing which is disclosed in U.S. Patent No. 5,412,654 to Perkins, and Zone Routing Protocol (ZRP) which is disclosed in U.S. Patent No. 6,304,556 to Haas. ZRP is a hybrid protocol using both proactive and reactive approaches.

15 These conventional routing protocols use a best effort approach in selecting a route from the source node to the destination node. Typically, the number of hops is the main criteria in such a best effort approach. In other words, the route with the least amount of hops is selected as the
20 transmission route.

Quality-of-service (QoS) routing in mobile ad hoc networks is gaining interest. To provide quality-of-service, the protocol needs not only to find a route but also to secure the resources along the route. Because of the limited, shared
25 bandwidth of the network, and lack of central controller which can account for and control these limited resources, nodes must negotiate with each other to manage the resources required for QoS routes. This is further complicated by frequent topology changes. Due to these constraints, QoS
30 routing is more demanding than best-effort routing.

Some examples of QoS routing approaches are set forth by Chenxi Zhu in the publication entitled "Medium Access Control and Quality-of-Service Routing for Mobile Ad Hoc Networks," 2001, and by M. Mirhakkak et al. in the publication

entitled "Dynamic Quality-of-Service for Mobile Ad Hoc Networks," MITRE Corp., 2000. Zhu discusses establishing bandwidth guaranteed QoS routes in small networks whose topologies change at a low to medium rate. Mirhakkak et al. are concerned with resource reservation requests which specify a range of QoS values while the network makes a commitment to provide service within this range.

At each node, admission control is performed to forward traffic from other nodes. Typically, conventional admission control protocols provide for full disclosure regarding routes and connectivity. In other words, each node shares all route and connectivity data with other nodes so that the best-effort routes are selected overall.

Summary of the Invention

In view of the foregoing background, it is therefore an object of the present invention to provide traffic tracking for multihop routes in a mobile ad hoc network.

This and other objects, features, and advantages in accordance with the present invention are provided by a method for tracking traffic in a mobile ad hoc network. The network includes a plurality of wireless mobile nodes and a plurality of wireless communication links connecting the plurality of nodes together. The method includes each node monitoring traffic communicated between nodes in the network, each node generating traffic information based upon how much traffic is being communicated between various nodes in the network, and each node storing the traffic information in a traffic database or table.

In the method, the traffic information may be based upon bandwidth and may include at least one of error rate, end-to-end delay, end-to-end delay variation, hop count, expected path durability, and priority. The traffic database may comprise a 1-hop traffic matrix. Monitoring may include

broadcasting a traffic activity query, and processing replies to the traffic activity query, or passively monitoring the traffic between nodes in the network. Each node may discover and select traffic routes based upon the stored traffic
5 information.

Furthermore, each node may generate traffic destination information based upon how many destinations each of various nodes communicates with in the network, and store the traffic destination information in a destination quantity
10 database or table. Thus, each node may also discover and select traffic routes based upon the stored traffic destination information.

A system aspect of the present invention is directed to a mobile ad hoc network having a plurality of mobile nodes, and a plurality of wireless communication links connecting the
15 plurality of mobile nodes together. Each mobile node comprises a communications device to wirelessly and unidirectionally or bi-directionally communicate with other nodes of the plurality of nodes via the wireless communication links, and a
20 controller to route communications via the communications device. The controller includes a traffic monitoring unit to monitor traffic communicated between nodes in the network, a traffic information generator to generate traffic information based upon how much traffic is being communicated between
25 various nodes in the network, and a traffic information buffer to store the traffic information in a traffic database.

Brief Description of the Drawings

FIGs. 1-4 are schematic diagrams of a mobile ad hoc network including QoS routing in accordance with the present
30 invention.

FIG. 5 is a flowchart illustrating the method steps for QoS routing in a mobile ad hoc network in accordance with the present invention.

FIG. 6 is a schematic diagram illustrating a router of a node in accordance with the network of the present invention.

FIG. 7 is a schematic diagram illustrating the
5 details of the controller of the router in FIG. 6.

FIGs. 8-10 are schematic diagrams of a mobile ad hoc network including admission control in accordance with the present invention.

FIG. 11 is a flowchart illustrating the method steps
10 for admission control in a mobile ad hoc network in accordance with the present invention.

FIG. 12 is a flowchart illustrating the method steps for policing traffic admission control in a mobile ad hoc network in accordance with the present invention.

FIG. 13 is a schematic diagram of a mobile ad hoc
15 network including traffic tracking in accordance with the present invention.

FIG. 14 is a flowchart illustrating the method steps for tracking traffic in a mobile ad hoc network in accordance
20 with the present invention.

FIGs. 15-17 are schematic diagrams of a mobile ad hoc network including dynamic channel allocation in accordance with the present invention.

FIG. 18 is a flowchart illustrating the method steps
25 for dynamic channel allocation in a mobile ad hoc network in accordance with the present invention.

Detailed Description of the Preferred Embodiments

The present invention will now be described more fully hereinafter with reference to the accompanying drawings,
30 in which preferred embodiments of the invention are shown. This invention may, however, be embodied in many different forms and should not be construed as limited to the embodiments set forth herein. Rather, these embodiments are

provided so that this disclosure will be thorough and complete, and will fully convey the scope of the invention to those skilled in the art. Like numbers refer to like elements throughout, and prime notation is used to indicate similar
5 elements in alternative embodiments.

As will be appreciated by those skilled in the art, portions of the present invention may be embodied as a method, data processing system, or computer program product. Accordingly, these portions of the present invention may take
10 the form of an entirely hardware embodiment, an entirely software embodiment, or an embodiment combining software and hardware aspects. Furthermore, portions of the present invention may be a computer program product on a computer-usable storage medium having computer readable program code on
15 the medium. Any suitable computer readable medium may be utilized including, but not limited to, static and dynamic storage devices, hard disks, optical storage devices, and magnetic storage devices.

The present invention is described below with
20 reference to flowchart illustrations of methods, systems, and computer program products according to an embodiment of the invention. It will be understood that blocks of the illustrations, and combinations of blocks in the illustrations, can be implemented by computer program
25 instructions. These computer program instructions may be provided to a processor of a general purpose computer, special purpose computer, or other programmable data processing apparatus to produce a machine, such that the instructions, which execute via the processor of the computer or other
30 programmable data processing apparatus, implement the functions specified in the block or blocks.

These computer program instructions may also be stored in a computer-readable memory that can direct a computer or other programmable data processing apparatus to

function in a particular manner, such that the instructions stored in the computer-readable memory result in an article of manufacture including instructions which implement the function specified in the flowchart block or blocks. The
5 computer program instructions may also be loaded onto a computer or other programmable data processing apparatus to cause a series of operational steps to be performed on the computer or other programmable apparatus to produce a computer implemented process such that the instructions which execute
10 on the computer or other programmable apparatus provide steps for implementing the functions specified in the flowchart block or blocks.

Referring initially to FIGs. 1-5, a method for determining a route from a source node to a destination node
15 in a mobile ad hoc network **20** will now be described. The network **20** includes a plurality of mobile nodes **30** including the source node **1** and the destination node **4** with intermediate nodes **2**, **3** and **5** therebetween. The nodes **30**, such as laptop computers, personal digital assistants (PDAs) or mobile
20 phones, are connected by wireless communication links **32** as would be appreciated by the skilled artisan. The method begins (block **100**) and includes transmitting a quality-of-service (QoS) route request RREQQ from the source node **1** to discover routing to the destination node **4** based upon a QoS parameter,
25 as indicated at block **102** in FIG. 5. The QoS parameter is preferably based upon available bandwidth, error rate, end-to-end delay, end-to-end delay variation, hop count, expected path durability, and/or priority as will be discussed in further detail below. The route request RREQQ includes a QoS
30 flow identifier and an updatable QoS link metric.

Furthermore, at block **104**, the method includes each intermediate node **2**, **3** and **5** determining whether the node can support the requested QoS parameter of the QoS route request RREQQ. If the node cannot support the QoS parameter of a

particular request RREQQ, then the request is denied or simply not forwarded by the node (block 106). If the node, for example node 3, can support the QoS parameter of a particular request RREQQ, then the node updates the QoS link metric, forwards the QoS route request to other intermediate nodes 2 and 5, and temporarily reserves node resources for that QoS route request (block 108). Intermediate nodes 2 and 5 also must determine whether they can support the requested QoS parameter of the QoS route request RREQQ forwarded from node 3. If so, the route request RREQQ with the updated QoS link metric is then forwarded to the destination node 4.

The destination node 4, upon receiving the QoS route request RREQQ, generates a reply RREPQ to the source node 1 including the flow identifier and updated QoS link metric for each discovered route (block 110). In other words, the destination node 4 may have received the forwarded route request RREQQ from any of various possible routes including, for example, 1-2-4 or 1-3-5-4. A reply RREPQ is generated in each case. At block 112, the source node 1 generates QoS route metrics based upon updated QoS link metrics in replies RREPQ from the destination node 4 for discovered routes. Also, at block 114, the source node 1 then selects a route to the destination node 4 based upon the QoS route metrics, and, at block 116, the source node transmits route confirmations CONFQ to intermediate nodes on the selected route. This is to confirm the use of the resources on the selected route that were temporarily reserved at block 108. Other temporarily reserved resources on discovered but non-selected routes may be permitted to time out by not transmitting CONFQ on those routes.

Also, the source node 1 may select at least one standby route either with or without sending confirmations CONFQ to the intermediate nodes on the standby route (block 122). Such a standby route may be for duplicate transmissions,

for additional reliability, or may be used as a backup route in case of route and/or QoS failure. At block **118**, the intermediate nodes **2**, **3** and **5**, and/or the destination node **4**, may detect at any time whether the node can continue to
5 support the requested QoS parameter of the QoS route request RREQQ. If the node can continue to support the request RREQQ throughout propagation of the traffic, reserved resources and associated routes may be permitted to time out if determined inactive, at block **126**, and be released, block **128**, if not
10 used for a period of time either by data traffic or by the sending of periodic CONFQ messages.

If the node cannot continue to support the request RREQQ, then the node generates a QoS error notification RERRQ to the source node **1** (block **120**). Here, the source node **1** may
15 maintain the selected route, upon receiving the QoS error notification RERRQ, while again transmitting a quality-of-service (QoS) route request RREQQ to discover a new routing path to the destination node **4** based upon the QoS parameter (block **102**). The source node **1** may also switch to the standby
20 route upon receiving the QoS error notification RERRQ (block **124**).

The described method can be applied to any type of On-Demand or Reactive routing protocol, such as Dynamic Source Routing (DSR) or Ad-Hoc On-Demand Distance Vector (AODV)
25 routing, or to any hybrid proactive/reactive protocol, such as Zone Routing Protocol (ZRP), as would be appreciated by the skilled artisan.

A more specific example considering minimum bandwidth allocation and a maximum delay constraint as
30 categories of QoS will now be described. For a fixed bandwidth allocation it is assumed that a node **30** is able to reserve a certain amount of capacity or bandwidth. Again, source node **1** of a traffic flow will send the QoS Route Request RREQQ for each required flow (the last Q in the notation indicates a QoS

request). The RREQQ message performs the function of discovering a route that can support the required QoS. Nodes that forward the RREQQ to the destination **4** will note if they can meet the requested QoS before passing on the RREQQ and they will temporarily reserve resources if needed. A Route Reply RREPQ packet is returned from the destination with an indication that the requested QoS can be met over that path. The source node **1** may then collect multiple potential paths to the destination **4** before deciding upon the best choice to provide the desired QoS. Once this path is determined, a Confirm CONFQ message is sent to the destination **4** along the indicated path. Along the way on this path any temporary resource reservations are confirmed to be permanent reservations. QoS reservations are timed out if not used for a specified period of time. If a link fails along the route or if the QoS requirement cannot be met, a Route Error (RERRQ) packet is generated and returned to the source node.

More specifically, when a new QoS route is needed to a given destination node **4**, the source node **1** broadcasts a RREQQ packet to the destination node. This is a special type of packet similar to the conventional RREQ packet used in a protocol such as DSR or AODV. The conventional RREQ broadcast is used for "best effort" service. The method of the present invention may still follow the conventional procedures established by the protocol for best effort service.

If a specified minimum capacity or bandwidth is required for a traffic flow, the special RREQQ packet is used to reserve a flow at a specified capacity to the destination **4**. In this case, a flow ID is assigned to the RREQQ by the source node **1** which combined with the source node address uniquely identifies the flow to any node in the network **20** that is forwarding the flow. The RREQQ packet also indicates the capacity that is to be reserved.

At each node **2**, **3** and **5** in the path to the destination **4**, the minimum capacity or bandwidth requirement is checked against available capacity to determine if a reservation can be made for the flow. If the node can
5 accommodate the required traffic flow, then the capacity is temporarily reserved for that flow ID. This temporary reservation is released if a CONFQ message is not received within a short period of time. If the RREQQ is meant to insure that a path can be found that does not exceed a specified
10 maximum delay, then each node along the path must be able to estimate its contribution to the total path delay and check to see if the total delay along the path so far plus its contribution exceeds the specified maximum delay bound.

Unlike conventional application of DSR and AODV for
15 "best effort" traffic, the RREQQ must be allowed to propagate all the way to the destination node **4** to determine if a valid path exists that satisfies the QoS requirement. If such a path is found, then the destination node **4** generates a RREPQ message to be returned to the source node **1**. This message
20 indicates to the source node that a valid path has been found to the destination node **4** that satisfies the requested QoS and a route has been established (in the case of DSR a source route is returned). Estimated path delay is included in the RREPQ for a request seeking a delay guarantee as well as for a
25 path guaranteeing capacity.

The source node **1** may receive multiple RREPQ for paths to the destination node **4** that can meet the required QoS. It will rank order these and send out a CONFQ message indicating its selection of a path on the highest ranked path.
30 The other paths may be kept as backup paths, but if the CONFQ is not sent on these paths, there is no guarantee that the required resources will be available if needed as a backup alternate path.

If at any intermediate node **2**, **3** and **5** or the destination node **4**, the requested QoS is violated and cannot be satisfied, then the RREQQ packet is discarded knowing that the path through this node cannot satisfy the requested QoS.

5 However, other paths may be found by the discovery process. If at any time a link fails along the route or if the QoS requirement cannot be met, a Route Error RERRQ packet is generated and returned to the source node **1** for each traffic flow affected by the failure. In this case either a backup

10 path must be used or the route discovery process is initiated again.

The described procedures are easily applied to the DSR protocol. The conventional DSR message types RREQ, RREP, RRER are defined as optional packet types, and can be used as

15 defined for the conventional operation of the protocol to support "best effort" traffic in a backwards compatibility mode. New optional packet types are defined to support QoS including the RREQQ, RREPQ, RRERQ, and CONFQ packet types to be used for managing QoS paths. Definition of the required

20 header fields for these types is straightforward based on the functions defined above. A special type of QoS source routed packet for QoS mission data would also be included. This packet would include the flow ID to identify which flow the packet belonged and to allow for metering of flow traffic.

25 The following procedures would be used if a failure causes a node to issue a RERRQ packet. If a RERRQ packet is received at the source node, then the current route is discarded and a backup route is tried. The first packet sent on the backup route will be another type of special QoS source

30 routed packet, the RREQT, that includes the flow ID and the QoS parameters. This packet could also include mission data. Each node along the path will have to check to see if they are still maintaining a temporary reservation for the flow. If not they will recheck to see if they can support the flow and make

a temporary reservation. If the packet reaches the destination with the flow supported at each intermediate node, then the destination node will return a RREPQ packet notifying the source that the path is valid.

5 If any node cannot support the flow, then the packet is discarded and the node returns a RERRQ packet to the source node notifying it that the path cannot support the requested QoS parameters. If the source node receives a RREPQ packet, then it sends a CONFQ message along the selected path
10 confirming the choice of path in addition to continuing to send the mission data for that traffic flow.

 If the source node receives a RERRQ packet, then it tries the same procedure on the next available backup path. If the source node has no more backup source routes to the
15 destination, the source node begins another route discovery process for a new QoS path to the destination node. Mission data flow is interrupted until a new route is found. For any specific protocol, the data structures required to manage the resources allocated to each traffic flow can be defined, and
20 how to identify the flows and how to look up the routes assigned to each flow can also be defined.

 Referring now additionally to Figs. 6 and 7, a system aspect of the invention will be described. A mobile ad hoc network **20** includes a plurality of mobile nodes **30**, and a
25 plurality of wireless communication links **32** connecting the plurality of mobile nodes together. Each mobile node includes a router **40** (FIG. 6) that has a communications device **42** to wirelessly and uni-directionally or bi-directionally communicate with other nodes via the wireless communication
30 links **32**, and a controller **44** to route communications via the communications device **42**. Also, a memory **46** may be included as part of the controller **44** or in connection with the controller.

As shown in FIG. 7, the controller **44** includes a route discovery unit **50** to transmit the quality-of-service (QoS) route requests to other nodes to discover routing to a destination node based upon at least one QoS parameter. Again, the route request includes a flow identifier and a QoS link metric. Also, a route request processing unit **52** determines whether the node can support a requested QoS parameter of a QoS route request and to update the QoS link metric, and a temporary resource reservation table **54** contains temporary node resource reservations for QoS route requests having supportable QoS parameters. Furthermore, a route metric formation unit **56** generates QoS route metrics based upon updated QoS link metrics in replies from nodes with node resource reservations, and a route selection unit **58** selects a route to the destination node based upon the QoS route metrics and to transmit route confirmations to nodes on a selected route.

The route selection unit **58** may select a standby route, such as for backup or duplicate transmissions, with or without sending confirmations CONFQ to the nodes on the standby route. The route request processing unit **52** detects whether the node can continue to support the requested QoS parameter of the QoS route request and, if not, generates the QoS error notification RERRQ. The route selection unit **58** preferably maintains the selected route, upon receiving a QoS error notification from another node, while the route discovery unit **50** transmits another quality-of-service (QoS) route request RREQQ to discover new routing to the destination node based upon the QoS parameter. The route selection unit **58** may switch to the standby route upon receiving the QoS error notification RERRQ from another node.

Another embodiment of the present invention provides traffic admission control for multihop routes in the mobile ad hoc network **22** while maintaining the quality of service

needed, and will be described with reference to FIGs. 8-11. Such an admission control method will adaptively allow a node to keep some resources for its own traffic, while sharing fairly in the forwarding of other's traffic. Again, the ad-hoc network is made up of a plurality of wireless mobile nodes **30** and a plurality of wireless communication links **32** connecting the plurality of nodes together.

The method for controlling traffic admission in the mobile ad hoc network **22** begins (block **200**) and includes a source node transmitting quality-of-service (QoS) route requests RREQQ to discover traffic routing based upon a QoS parameter (block **202**). At block **208**, each node **30** in the network **22** calculates a node QoS tag value to make traffic admission control decisions. The node QoS tag value is a function of at least one node specific QoS metric. The QoS parameter may be based upon, for example, bandwidth, error rate, end-to-end delay, end-to-end delay variation, hop count, expected path durability, and/or priority, while the node specific QoS metric may include one or more of available power, available bandwidth by the node, recent error rate, recent delay, available bandwidth by other nodes within a range, and node queue size, for example. The QoS tag value may be a weighted sum of each term, or a vector with each term as an element.

Each node **30** determines admission based upon the calculated QoS tag value and the QoS parameter of QoS route requests RREQQ, and may reply to the source node, regarding whether traffic will be admitted in response to the QoS route requests (block **214**). Furthermore, each node **30** may calculate route and connectivity information associated with the node (block **210**), and transmit the route and connectivity information and the QoS tag value to other nodes for traffic route selection (block **212**).

Calculating the node QoS tag value **208** may include querying other nodes within a range for information regarding at least one QoS metric (block **204**), and processing the QoS metric information received from the other nodes and the at least one node specific QoS metric to calculate the node QoS tag value. Calculating the node QoS tag value may further comprise verifying that each other node within the range has replied with QoS metric information (block **206**).

More specifically, most of the QoS metric terms such as available power, available bandwidth by the node, recent error rate, recent delay, and node queue size, are known locally to the node. However, available bandwidth by other nodes within a range, for example, is not known locally. Thus, referring to FIG. 8, if node **1** issues a request to node **4** for 5 Mbps of an 11 Mbps transmission medium, node **4** must check to see if any other nodes in range (here nodes **1**, **3** and **5**) have already made prohibitive commitments. So, node **4** broadcasts a CHECK message and any nodes within range that have committed bandwidth will send a CHECK REPLY back indicating such. Node **4** makes sure that it has heard a CHECK REPLY from all nodes that it has heard from lately. With the received information, node **4** can now make a decision on whether it can support the QoS parameter of the route request RREQQ.

Replying to QoS route requests (block **214**) may comprise indicating what traffic routing the node can support based upon the node QoS tag value, when the node cannot support the QoS parameter of the route request. For example, if node **4** cannot commit to the request, it may issue a reply that describes the most that it can support. Accordingly, the source can decide whether the level is good enough or whether to scale back the request and issue a relaxed QoS request RREQQ.

As discussed, conventional approaches provide full disclosure regarding routes and connectivity. In other words,

each node **30** shares all that it knows with others, so that "best" (usually fewest hops) routes are selected overall. In this invention, this route and connectivity information is tagged with a value that allows other nodes to use it based on the Quality of Service needed. Additionally, the node sharing the information can decide on the level of QoS that will be allowed to use that information. This decision can be based on a common set of rules, or per node since some nodes will be advantaged. For example, a node that finds itself forwarding many packets, whose battery is running out, and is having trouble finding bandwidth for its own traffic may advertise his routes and connectivity to certain other nodes with a tag that disallows all but the most important (high priority) packets.

A system aspect of this embodiment of the present invention is directed to the mobile ad hoc network **22** including the plurality of mobile nodes **30**, and the plurality of wireless communication links **32** connecting the plurality of mobile nodes together. As described earlier with reference to FIGs. 6 and 7, each mobile node has a router **40** that includes the communications device **42** to wirelessly and unidirectionally or bi-directionally communicate with other via the wireless communication links, and a controller **44** to route communications via the communications device. The controller **44** includes a route discovery unit **50** to transmit quality-of-service (QoS) route requests to other nodes to discover routing to a destination node based upon at least one QoS parameter. Here, a QoS tag calculation unit **60** calculates the node QoS tag value to make traffic admission control decisions. A traffic admission controller **62** determines whether to admit traffic in response to QoS route requests based upon the calculated QoS tag value and the QoS parameter of QoS route requests.

The controller **44** may also include a connectivity calculator **64** to calculate route and connectivity information associated with the node, which may be transmitted to other nodes for traffic route selection. The QoS tag calculation unit **60** may query other nodes within a range for information regarding at least one QoS metric, and process the QoS metric information received from the other nodes and the at least one node specific QoS metric to calculate the node QoS tag value. Also, the QoS tag calculation unit **60** may verify that each other node within the range has replied with QoS metric information.

Furthermore, the route request processing unit **52** replies to QoS route requests to indicate whether the node can support the QoS parameter of the route request and admit the traffic. Also, the route request processing unit **52** may indicate what traffic routing the node can support based upon the node QoS tag value, when the node cannot support the QoS parameter of the route request.

Another embodiment of the present invention provides traffic policing for multihop routes in a mobile ad hoc network **22**, and will be described with reference to FIG. 12. as previously described, the network **22** includes the plurality of wireless mobile nodes **30** and the plurality of wireless communication links **32** connecting the plurality of nodes together. The method begins at block **300** and includes nodes transmitting quality-of-service (QoS) route requests RREQQ to discover traffic routing based upon a QoS parameter (block **302**) as described in the other embodiments. Here, the QoS route requests RREQQ include at least the traffic flow identifier. At block **304**, each node calculates a node QoS tag value to make traffic admission control decisions, and each node determines whether to admit traffic in response to QoS route requests based upon the calculated QoS tag value and the QoS parameter of QoS route requests (block **306**). Also, at

block **308**, each node replies to QoS route requests to indicate whether the node can support the QoS parameter of the route request and admit the traffic. However, in this embodiment, each node polices admitted traffic based upon the traffic flow
5 identifier to ensure that admitted traffic does not exceed the QoS parameter of the QoS route request RREQQ (block **310**).

Again, the QoS parameter may be based upon available bandwidth, error rate, end-to-end delay, end-to-end delay variation, hop count, expected path durability, and/or
10 priority, for example, while the node specific QoS tag value may be a function of at least one of available power, available bandwidth by the node, recent error rate, recent delay, available bandwidth by other nodes within a range, and node queue size, for example. In other words, if a request
15 RREQQ includes a requirement for certain amount of bandwidth, for example, and the node admits the traffic associated with the request, then the node polices itself to ensure that the admitted traffic does not exceed the requested bandwidth.

The method preferably includes each node preventing
20 propagation of traffic that exceeds the QoS parameter of the QoS route request (block **312**). This step may include buffering traffic that exceeds the QoS parameter of the QoS route request, and propagating buffered traffic at the QoS parameter of the QoS route request. Alternatively, each node
25 may propagate buffered traffic when required resources become available, or simply discard traffic that exceeds the QoS parameter of the QoS route request. Furthermore, as described in the other embodiments, replying to QoS route requests may comprise indicating what traffic routing the node can support
30 based upon the node QoS tag value, when the node cannot support the QoS parameter of the route request.

Referring again to FIG. 7, the controller **44** includes a traffic policing unit **84** to police the admitted traffic based upon the traffic flow identifier to ensure that

admitted traffic does not exceed the QoS parameter of the QoS route request. Also, the traffic policing unit **84** preferably includes an excess traffic buffer **86** for storing the excess traffic.

5 More specifically, the traffic flow ID is used in route tables and in the QoS packets (both control and data). As discussed, this provides an identifier for performing admission control. The source node that has obtained a reservation for a path of a certain capacity, for example, to
10 the destination node can use the flow ID and meter the traffic to perform policing of the traffic. This guarantees that it never admits more than agreed upon capacity for that flow ID. In addition, each node in the path to the destination can perform policing against the allocated capacity. Of course
15 criteria other than the available capacity could be used as a criteria for deciding whether to support a given flow request. For example, a node running low on battery power may not want to support a given traffic flow. Then in this case, the RREQQ message can be ignored thereby disallowing use of the node as
20 a forwarding node for the requested traffic flow.

 Another embodiment of the present invention provides traffic tracking for multihop routes in a mobile ad hoc network, and will be described with reference to FIGs. 13 and 14. As shown in FIG. 13, the network **24** again includes a
25 plurality of wireless mobile nodes **30** and a plurality of wireless communication links **32** connecting the plurality of nodes together. The method begins at block **400** (FIG. 14) and includes each node monitoring traffic communicated between nodes **30** in the network **24** (block **402**). Each node **30** generates
30 traffic information based upon how much traffic is being communicated between various nodes in the network **24** (block **404**), and each node stores the traffic information locally in a buffer as a traffic database (block **406**).

In the method, the traffic information is preferably based upon bandwidth and may include error rate, end-to-end delay, end-to-end delay variation, hop count, expected path durability, and/or priority. The traffic database may comprise a 1-hop traffic matrix. In other words, the database for a specific node 1 would include traffic information for each link 32 between nodes 2-8 in the network. In FIG. 13, node 1 needs a traffic route A to node 6. Here, if nodes 7 and 8 are sending large amounts of traffic, but nodes 1-6 are not, it would be better to route traffic through 1-2-3-4-5-6 rather than 1-7-8-6 even though it would result in more hops.

The method may be advantageous to routing protocol selection, protocol parameter optimization, and route selection. A traffic matrix is shown in the example below. For a 7 node network, each element in the matrix denotes how much traffic, if any, is being sent from the source node on that row to the destination node on that column. Here, the traffic is quantified in terms bandwidth over some interval (recent bandwidth used may be weighted more), and may include packet loss rate, delay, etc. If the traffic matrix is sparsely populated (lots of zero or near zero bandwidth entries), a reactive routing protocol would be more advantageous, since routes are not constantly updated that will not be used anyway. Conversely, a dense traffic matrix would indicate lots of interaction between nodes 30 and a proactive or hybrid protocol may provide benefits. Accordingly, the method may include each node selecting a route discovery protocol, such as a reactive, proactive or hybrid protocol, based upon the stored traffic information and (block 412).

30

Source	Destination						
	1	2	3	4	5	6	7
1	N/A	1 Mbps	0	0	0	1 Mbps	300 kbps
2	0	N/A		10 kbps	0	0	0
3	0	0	N/A	0	0	10 kbps	0
4	10 kbps	0	0	N/A	0	1 Mbps	0
5	0	300 kbps		10 kbps	N/A	0	0
6	0	0	1 Mbps	0	0	N/A	10 kbps
7	300 kbps	0	300 kbps	0	0	0	N/A

TRAFFIC DATABASE

5 Nodes know what traffic they are sending, receiving and forwarding. To know traffic they are not directly involved with, they can monitor or be explicitly sent messages containing traffic data. Routing protocols such as DSR that collect route information promiscuously (by hearing other nodes' requests RREQ and replies RREP, or by observing the source route in data packets) could be adapted to build much of the traffic matrix. Link-state routing protocols, such as optimized link state routing (OLSR), already share route information, and could be extended to share traffic matrix information, since each node knows what it sends to whom, and at what quality. Also, a protocol could set timers according to expected delays through a sequence of hops, based upon the traffic matrix bandwidths, since it will know what delays to expect due to traffic congestion. This may reduce or eliminate unnecessary timeouts from occurring.

10

15

20

Furthermore, at block **408**, each node **30** may generate traffic destination information based upon how many destinations each of various nodes communicates with in the network **24**, and store (block **410**) the traffic destination information in a destination quantity database. Thus, each node **30** may also discover and select traffic routes based upon the stored traffic destination information. In other words, the destination quantity database would reveal the number of destinations that each of the particular nodes is communicating with.

Referring again to FIG. 7, the controller **44** of a router **40** in a network **24** in accordance with this embodiment, includes a traffic monitoring unit **70** to monitor traffic communicated between nodes **30** in the network. A traffic information generator **76** generates traffic information based upon how much traffic is being communicated between various nodes in the network, and a traffic information buffer **78** stores the traffic information in a traffic database.

The traffic monitoring unit **70** may broadcast a traffic activity query, and processes replies to the traffic activity query. Alternatively, the traffic monitoring unit **70** may passively monitor the traffic between nodes **30** in the network **24**. The route discovery unit **50** discovers routing to a destination node based upon the stored traffic information, and the route selection unit **58** selects traffic routes to the destination node based upon the stored traffic information. Also, the route discovery unit **50** may process the traffic information stored in the traffic database to select one of a reactive, proactive and hybrid route discovery process, and discovers traffic routes with the selected route discovery process. Each traffic route comprises a combination of wireless communication links **32**.

A traffic destination information generator **72** generates traffic destination information based upon how many

destinations each of various nodes **30** communicates with in the network **24**, and a destination information buffer **74** stores the traffic destination information in a destination quantity database. The route discovery unit **50** may also discover
5 routing to a destination node based upon the stored traffic destination information, and the route selection unit **58** may select traffic routes to the destination node based upon the stored traffic destination information.

Another embodiment of the present invention provides
10 dynamic channel allocation in the mobile ad hoc network to efficiently make use of a plurality of channels. A method for dynamic channel allocation will be described while referring to FIGs. 15-18. Here, the network **26** includes a plurality of wireless mobile nodes **30** and a plurality of wireless
15 communication links **32** connecting the plurality of nodes together over a plurality of channels. IEEE 802.11 spinoffs like 802.11a will make use of the ISM spectrum in the **5** GHz band. In this band, there is more bandwidth available to support many channels. As a result, a process to automatically
20 assign a channel to an **802.11** node would be important. Such a channel decision would be based on current channel utilization and sampling of the other channels. Using dynamic channel selection would provide better performance since the spectrum would be used evenly. Additionally, channel use could be
25 throttled such that QoS is maintained for current stations using the channel.

The method begins at block **500** (FIG. 18) and includes each node **30** monitoring link performance on a first channel. Link performance is based upon a quality of service
30 (QoS) threshold, such as bandwidth, error rate, end-to-end delay, end-to-end delay variation, hop count, expected path durability, and priority, for example. At block **504**) each node scouts one or more other available channels when the monitored link performance on the first channel falls below the QoS

threshold, for example, minimum bandwidth or maximum delay. Scouting may include periodically monitoring other channels for link performance.

Scouting may comprise switching to a second channel
5 (block **512**), broadcasting a channel activity query to determine the link performance for the second channel (block **516**), and processing replies to the channel activity query to determine the link performance for the second channel at block **518**. Furthermore, each node **30** may switch back to the first
10 channel and broadcast a channel change message if the link performance on the second channel is above the QoS threshold (block **506**), or switch to subsequent channels and broadcast channel activity queries to determine the link performance for the those channels if the link performance on the previous
15 channel is below the QoS threshold (block **504**).

Alternatively, scouting may comprise switching to another channel (block **512**), and passively monitoring the link performance for the second channel at block **514**. Again, each node **30** may switch back to the first channel and broadcast a
20 channel change message if the link performance on the second channel is above the QoS threshold (block **506**), or switch to subsequent channels and passively monitor the link performance for those channels if the link performance on the previous channel is below the QoS threshold (block **504**). Also, each
25 node **30** may store link performance information of each of the plurality of channels (block **508**) and/or store channel information for neighboring nodes at block **510**. In other words, each node **30** may keep track of what channel other nodes are using.

30 For example, as shown in FIGs. 15-17, the network **26** includes nodes **30** and links **32**. Nodes 1A-5A are currently using a first channel, while nodes 1B-5B are currently using a second channel. Node **2B** determines that the link performance for the second channel is falling or has fallen below a QoS

threshold, such as below a minimum bandwidth. Node **2B** switches to the first channel and broadcasts a channel activity query CAQ to nodes within 1-hop of node **2B** (FIG. 16). Nodes **1A**, **2A** and **3A** send channel activity replies CAR to node **2B** with
5 information on the link performance of the first channel (FIG. 17). If the bandwidth on the first channel is acceptable to node **2B**, it will return to the second channel and broadcast a channel change message to inform any nodes **1B**, **3B**, **4B** and **5B** that it is changing to the first channel. These nodes would
10 then note where node **2B** can be found for future reference. If the bandwidth is not acceptable, node **2B** will move to a third channel and repeat the steps. If all channels have been visited and node **2B** has not found bandwidth above the QoS threshold, then it will select the best one, and may
15 periodically search for a better channel.

A system aspect of this embodiment of the present invention is directed to the mobile ad hoc network **26** having a plurality of mobile nodes **30**, and a plurality of wireless communication links **32** connecting the plurality of mobile
20 nodes together over a plurality of channels. Referring to FIGs. 6 and 7, each mobile node comprises a router **40** having a communications device **42** to wirelessly and unidirectionally or bi-directionally communicate with other nodes via the wireless communication links **32**, and a controller **40** to route
25 communications via the communications device. The controller **40** includes a link performance monitor **80** to monitor link performance on a first channel. A channel scouting unit **82** scouts one or more other available channels when the monitored link performance on the first channel falls below the QoS
30 threshold.

The channel scouting unit **82** switches to a second channel, broadcasts a channel activity query to determine the link performance for the second channel, and processes replies to the channel activity query to determine the link

performance for the second channel. Also, the channel
scouting unit **82** switches back to the first channel and
broadcasts a channel change message if the link performance on
the second channel is above the QoS threshold, or switches to
5 subsequent channels and broadcasts channel activity queries to
determine the link performance for those channels if the link
performance on the previous channel is below the QoS
threshold. Alternatively, the channel scouting unit **82** may
switch to another channel and passively monitor the link
10 performance for the second channel. A link performance
information memory **66** stores the link performance information
of each of the plurality of channels, and a channel
information memory **68** stores channel information for
neighboring nodes.

15

THAT WHICH IS CLAIMED IS:

1. A method for tracking traffic in a mobile ad hoc network comprising a plurality of wireless mobile nodes and a plurality of wireless communication links connecting the
5 plurality of nodes together, the method comprising:

at each node, monitoring traffic communicated between nodes in the network;

at each node, generating traffic information based
10 upon how much traffic is being communicated between various nodes in the network; and

at each node, storing the traffic information in a traffic database.

15 2. A method according to Claim 1 wherein the traffic information is based upon bandwidth and includes at least one of error rate, end-to-end delay, end-to-end delay variation, hop count, expected path durability, and priority.

20 3. A method according to Claim 1 further comprising at each node, discovering and selecting traffic routes based upon the stored traffic information.

25 4. A method according to Claim 1 further comprising:

at each node, generating traffic destination information based upon how many destinations each of various nodes communicates with in the network; and

30 at each node, storing the traffic destination information in a destination quantity database.

5. A method according to Claim 4 further comprising at each node, discovering and selecting traffic routes based upon the stored traffic destination information.

6. A method for determining routes in a mobile ad hoc network comprising a plurality of wireless mobile nodes and a plurality of wireless communication links connecting the nodes together, the method comprising:

at each node, monitoring traffic communicated between nodes in the network;

at each node, generating traffic information based upon traffic being communicated between various nodes in the network;

at each node, storing the traffic information in a traffic database;

at each node, processing the traffic information stored in the traffic database to select one of a reactive, proactive and hybrid route discovery process;

at each node, discovering traffic routes with the selected route discovery process, each traffic route comprising a combination of wireless communication links; and

at each node, selecting discovered routes for communication with other nodes.

7. A method according to Claim 6 wherein the traffic information is based upon bandwidth and includes at least one of error rate, end-of-end delay, end-to-end delay variation, hop count, expected path durability, and priority.

8. A method according to Claim 6 further comprising:

at each node, generating traffic destination information based upon how many destinations each of various nodes communicates with in the network; and

at each node, storing the traffic destination information in a destination quantity database.

9. A mobile ad hoc network comprising:
a plurality of mobile nodes; and
a plurality of wireless communication links
connecting the plurality of mobile nodes together;
5 each mobile node comprising
a communications device to wirelessly and
communicate with other nodes of the plurality of
nodes via the wireless communication links, and
a controller to route communications via the
10 communications device, and comprising
a traffic monitoring unit to monitor
traffic communicated between nodes in the
network,
a traffic information generator to
15 generate traffic information based upon how
much traffic is being communicated between
various nodes in the network, and
a traffic information buffer to store the
traffic information in a traffic database.

20

10. A network according to Claim 9 wherein the
traffic information is based upon bandwidth and includes at
least one of error rate, end-to-end delay, end-to-end delay
variation, hop count, expected path durability, and priority.

25

11. A network according to Claim 9 further
comprising:
a route discovery unit to discover routing to a
destination node based upon the stored traffic information;
30 and
a route selection unit to select traffic routes to
the destination node based upon the stored traffic
information.

12. A network according to Claim 9 wherein the route discovery unit processes the traffic information stored in the traffic database to select one of a reactive, proactive and hybrid route discovery process, and discovers traffic
5 routes with the selected route discovery process, each traffic route comprising a combination of wireless communication links.

13. A network according to Claim 9 further
10 comprising:
a traffic destination information generator to generate traffic destination information based upon how many destinations each of various nodes communicates with in the network; and
15 a destination information buffer to store the traffic destination information in a destination quantity database.

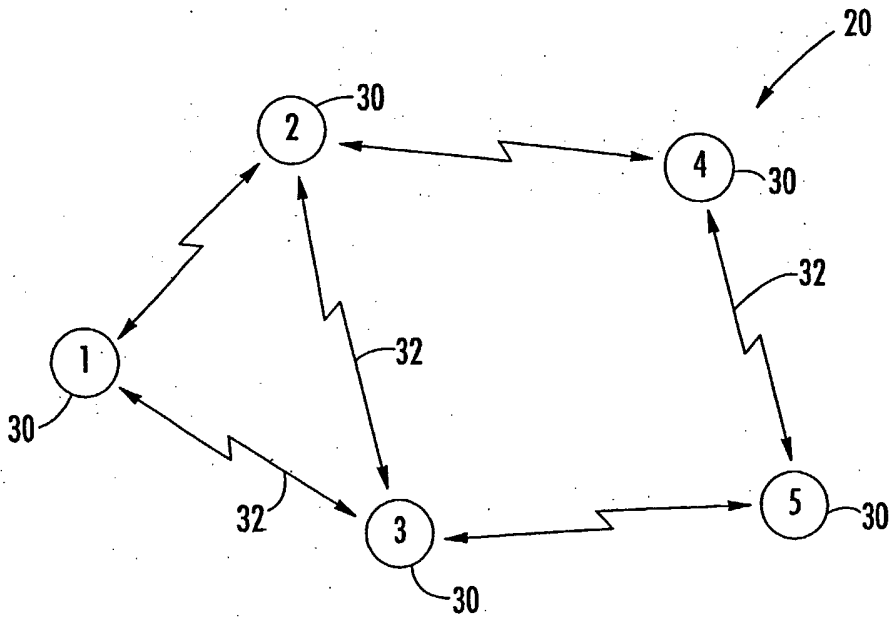

FIG. 1.

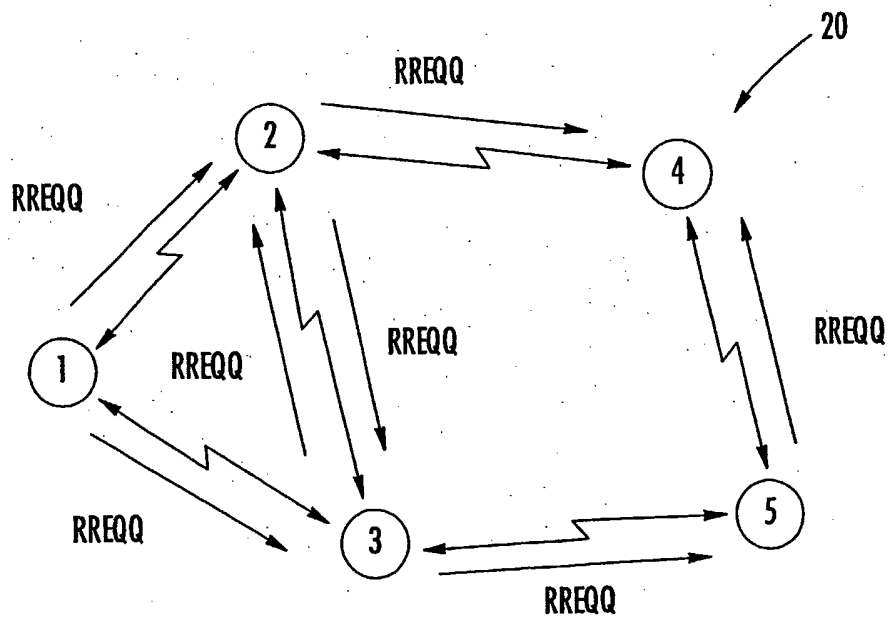

FIG. 2.

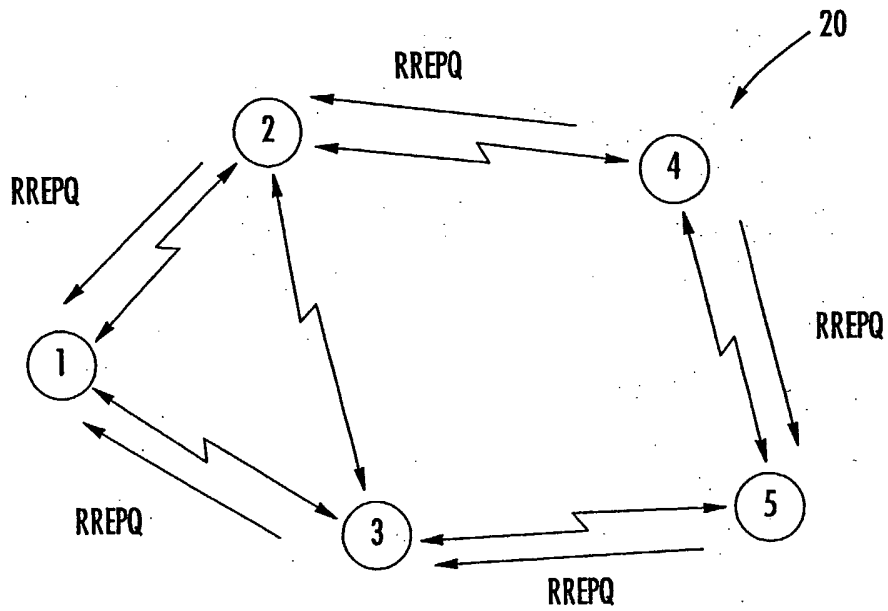

FIG. 3.

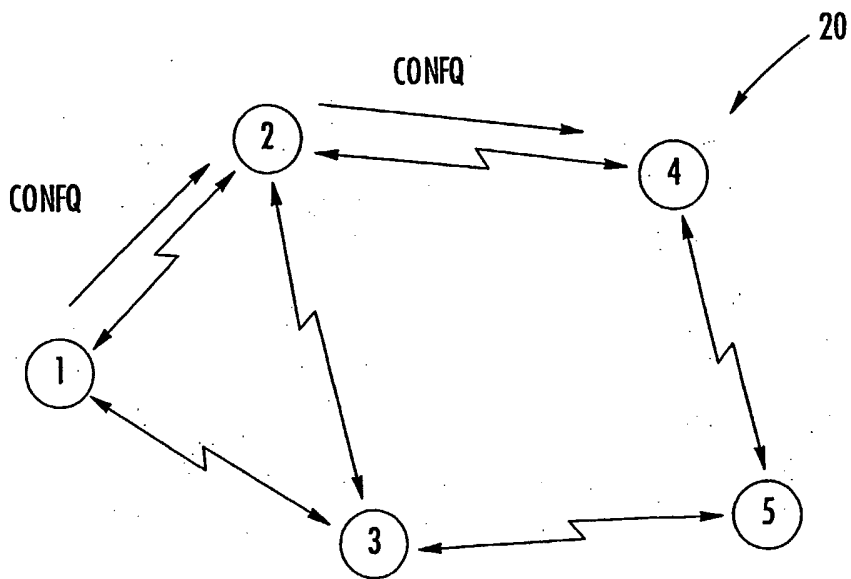

FIG. 4.

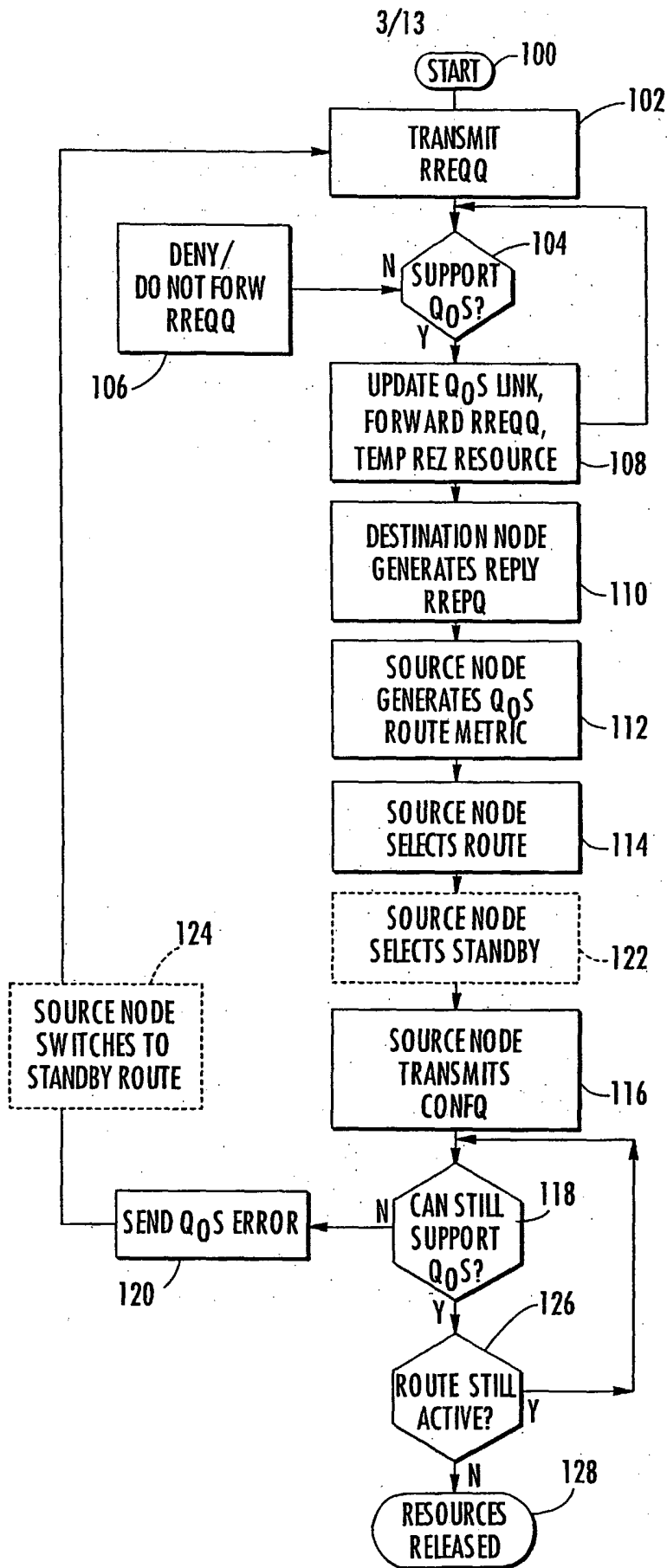

FIG. 5.

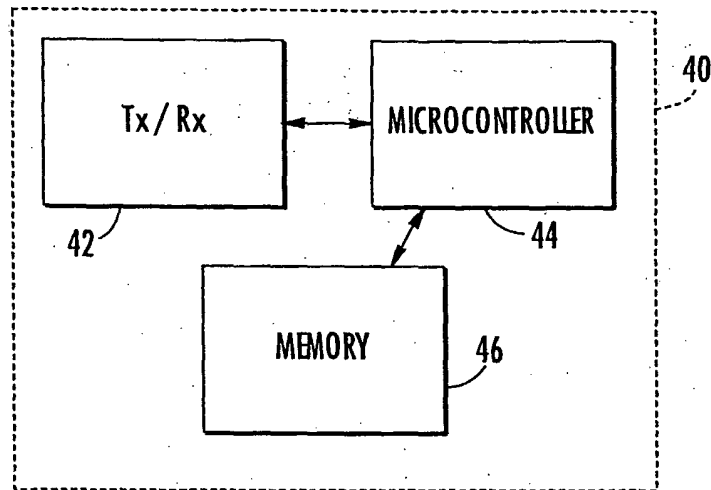

FIG. 6.

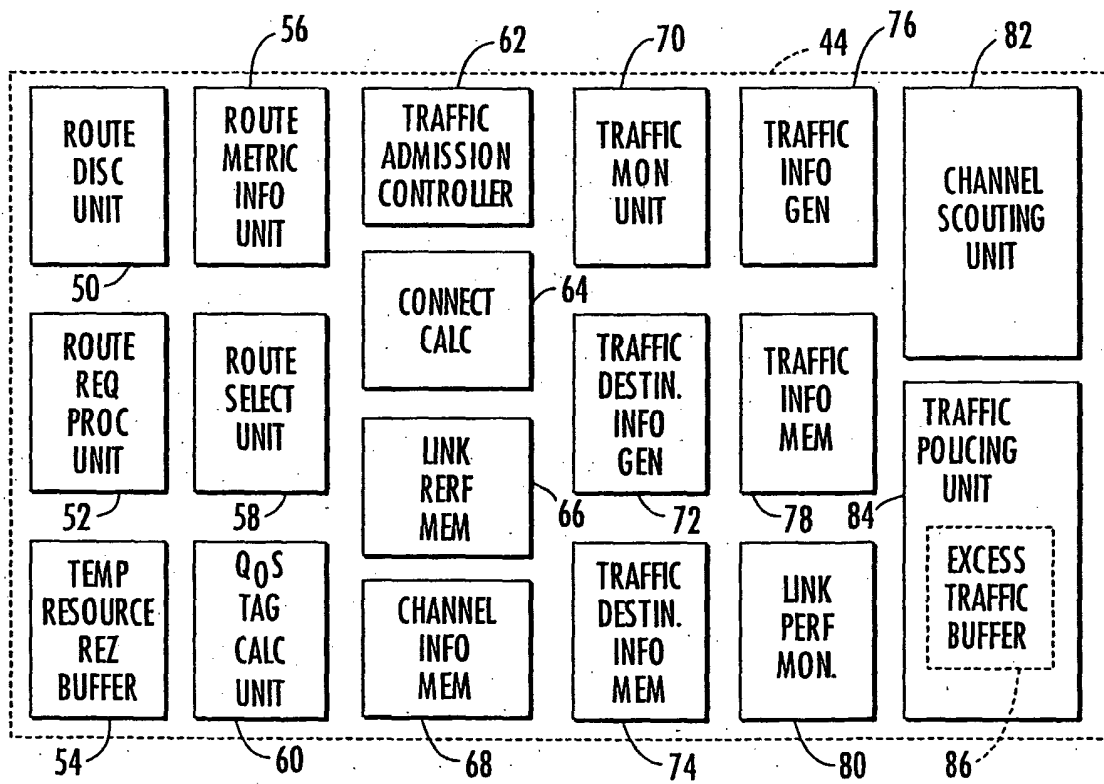

FIG. 7.

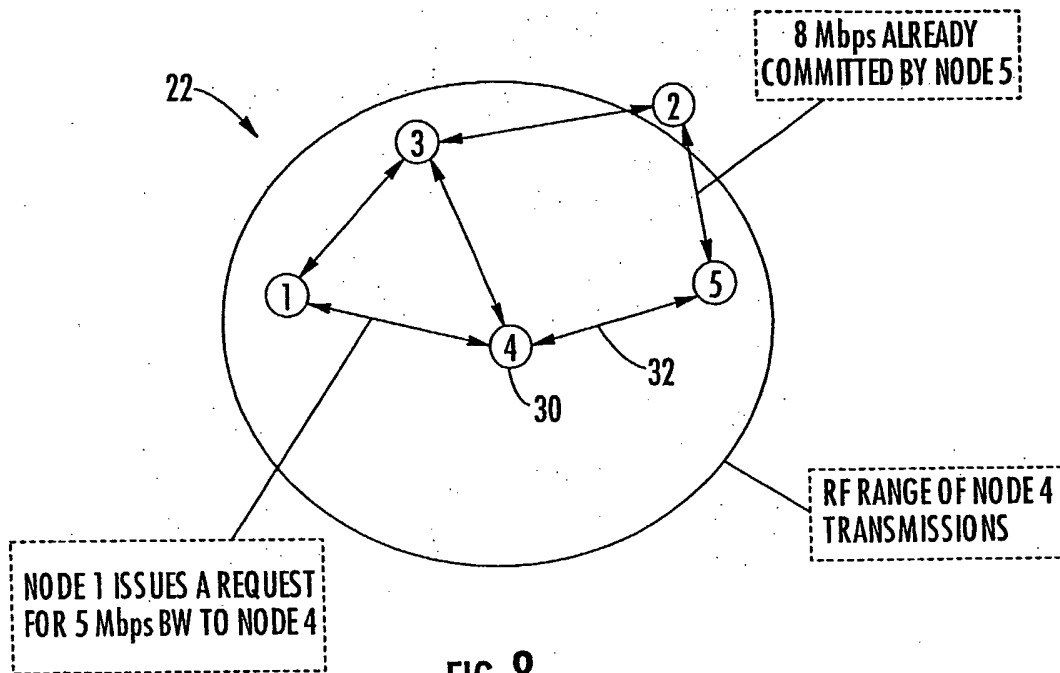

FIG. 8.

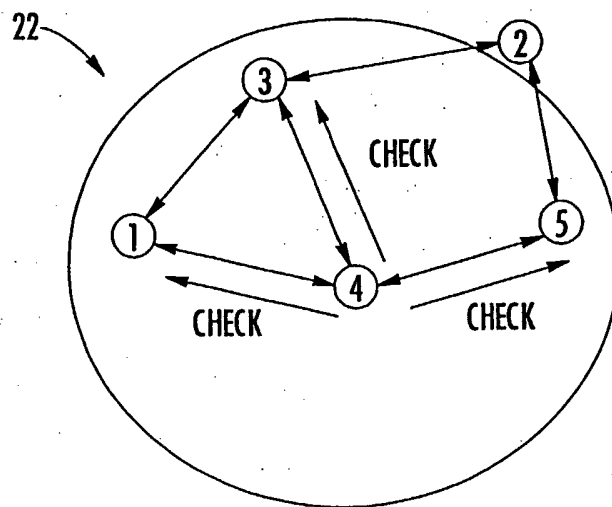

FIG. 9.

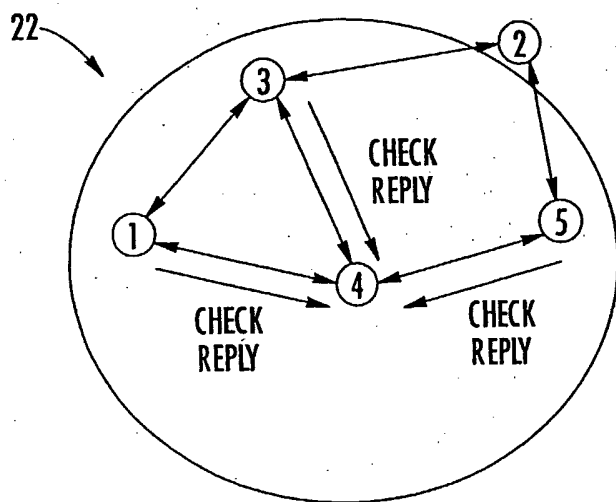

FIG. 10.

7/13

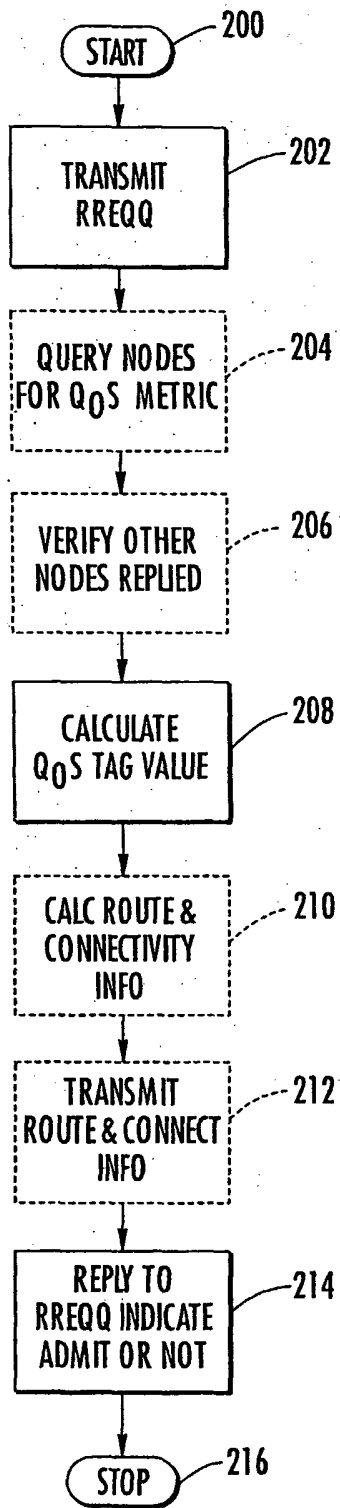

FIG. 11.

8/13

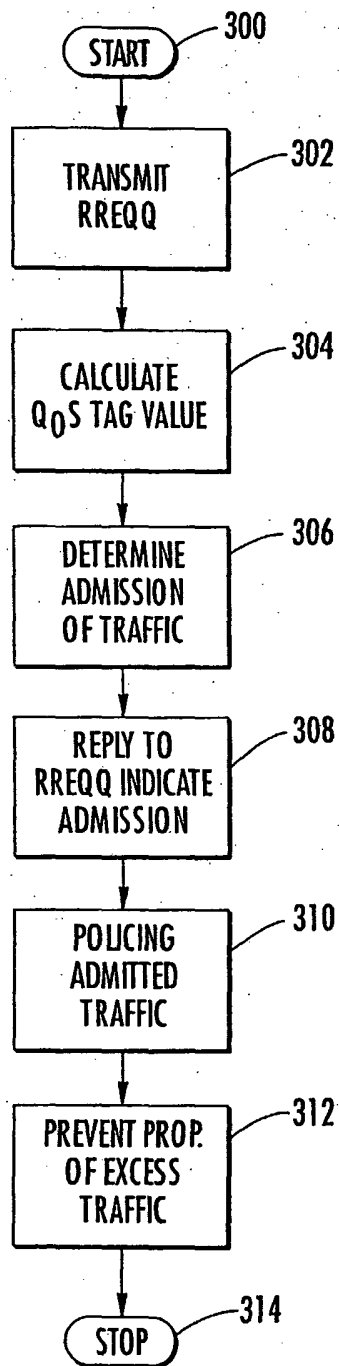

FIG. 12.

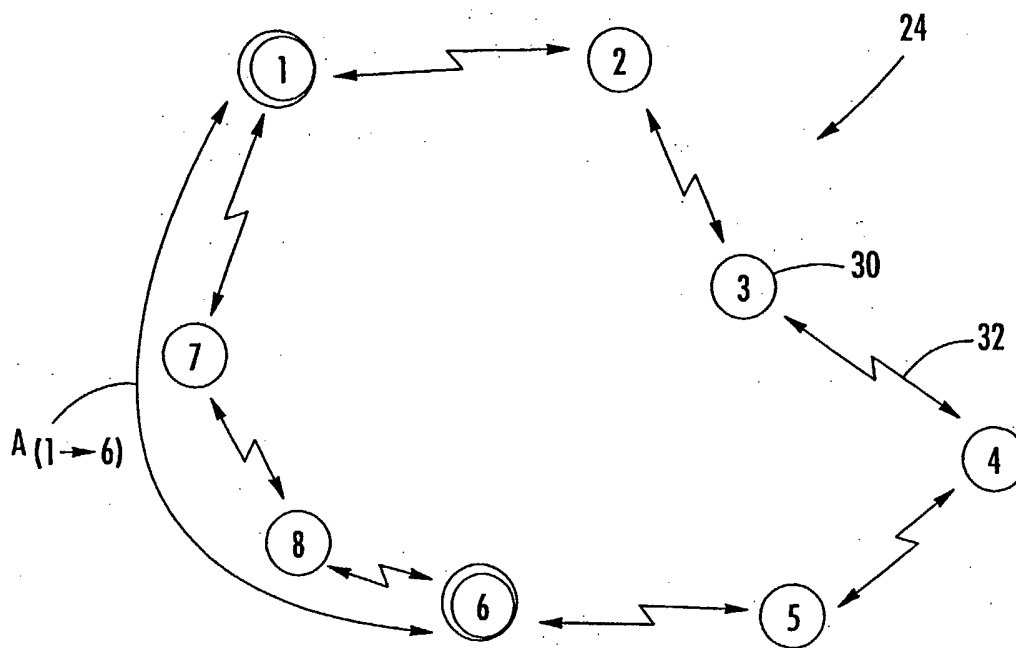

FIG. 13.

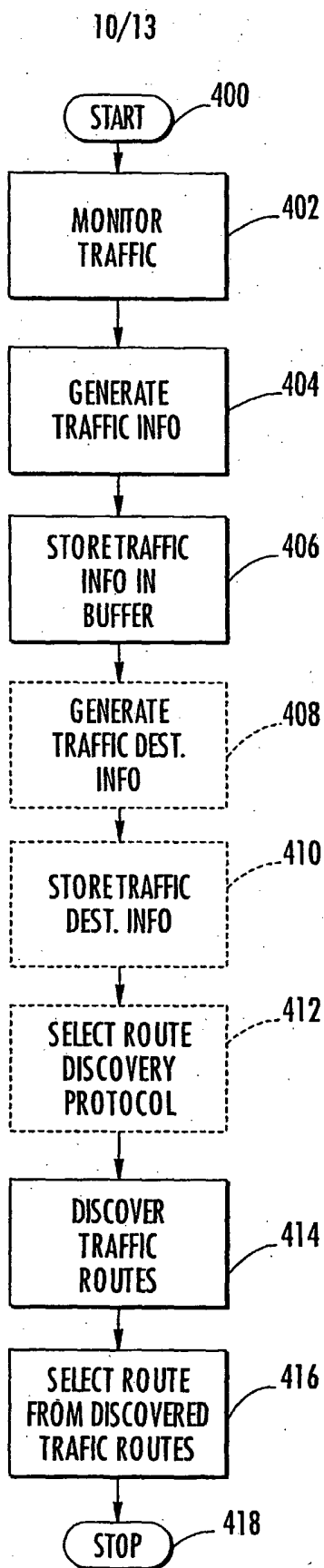

FIG. 14.

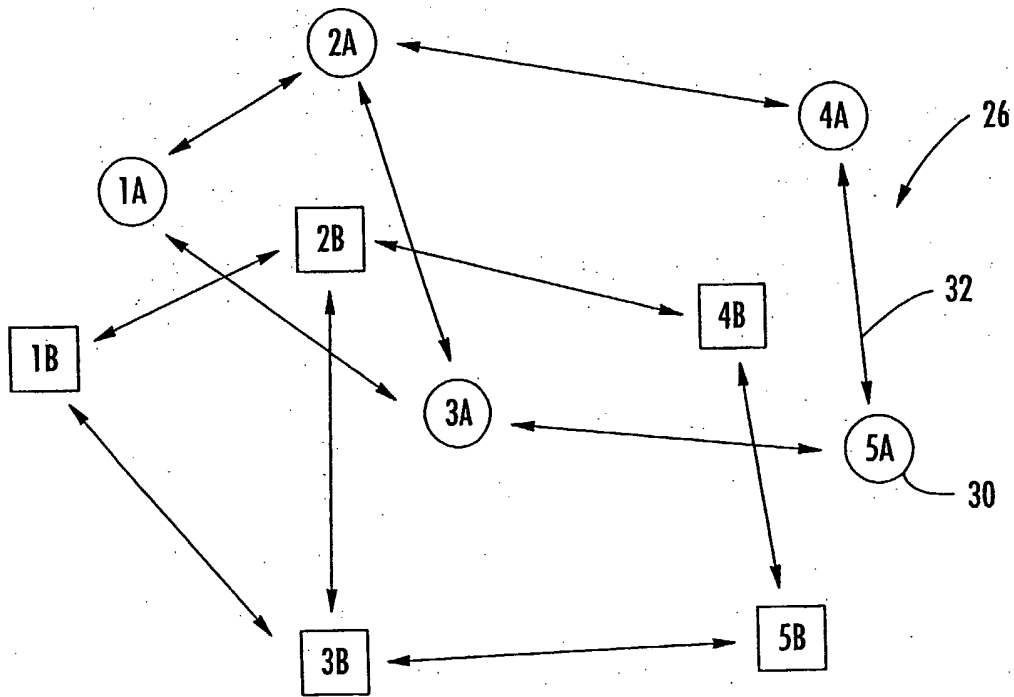

FIG. 15.

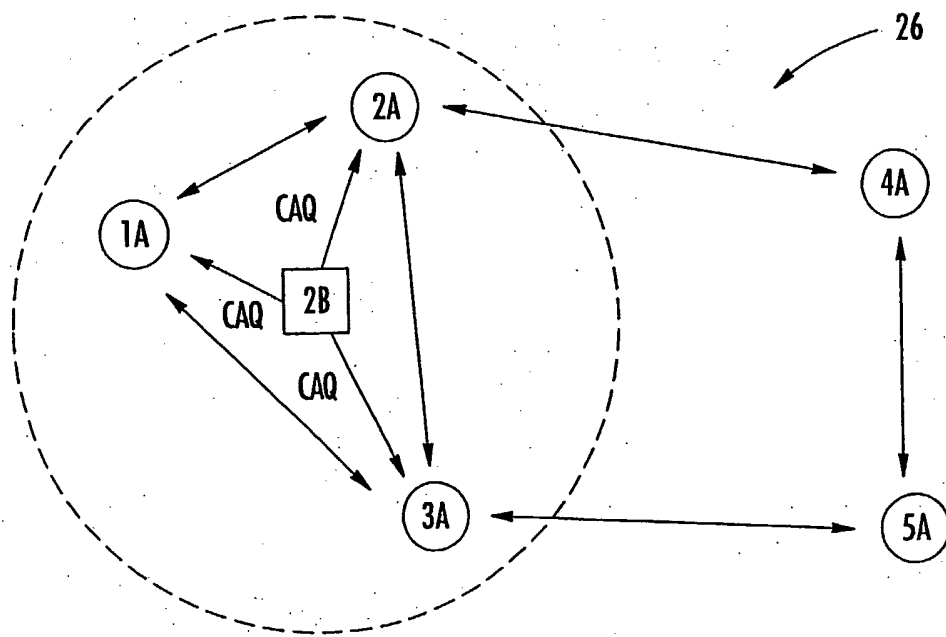

FIG. 16.

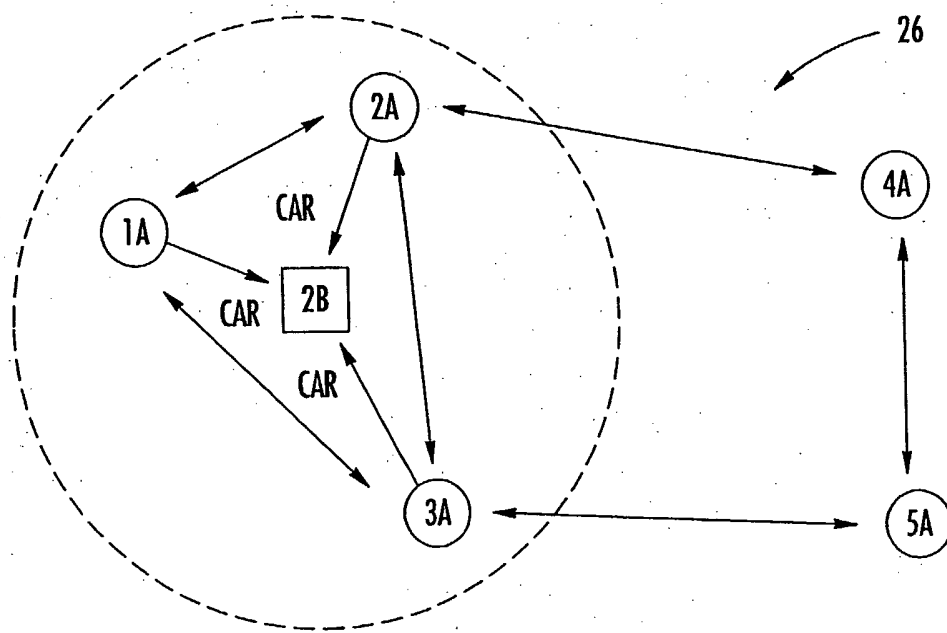

FIG. 17.

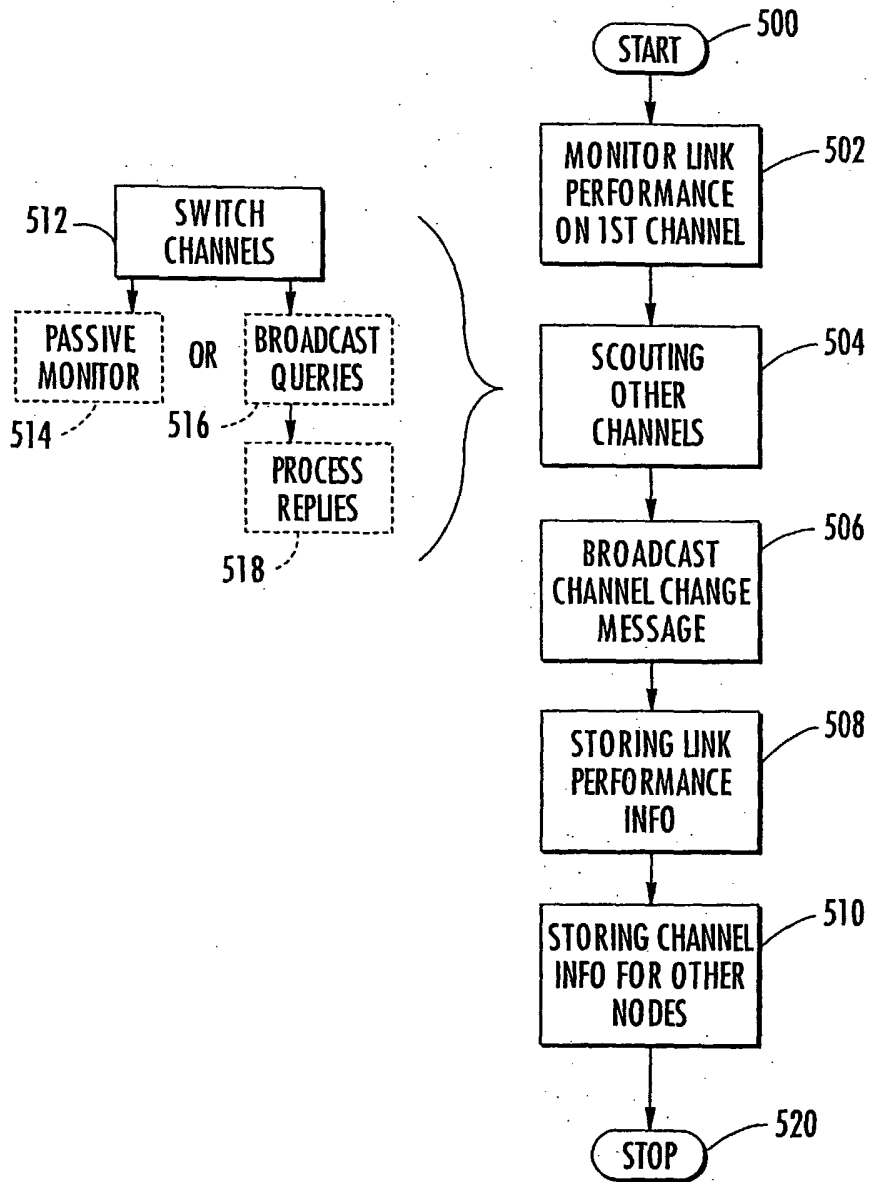
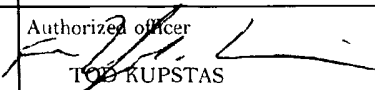

FIG. 18.

INTERNATIONAL SEARCH REPORT

International application No.
PCT/US03/13144

A. CLASSIFICATION OF SUBJECT MATTER		
IPC(7) : G06F 15/173 US CL : 700/238		
According to International Patent Classification (IPC) or to both national classification and IPC		
B. FIELDS SEARCHED		
Minimum documentation searched (classification system followed by classification symbols)		
U.S. : 709/238, 224, 239-244		
Documentation searched other than minimum documentation to the extent that such documents are included in the fields searched		
Electronic data base consulted during the international search (name of data base and, where practicable, search terms used)		
EAST		
C. DOCUMENTS CONSIDERED TO BE RELEVANT		
Category*	Citation of document, with indication, where appropriate, of the relevant passages	Relevant to claim No.
X	US 6,130,881 A (Stiller et al) 10 October 2000, col. 4, line 3-col. 11, line 44.	1-13
A	US 6,304,913 B1 (RUNE) 16 October 2001, col. 2, line 65-col. 9, line 42.	1-13
A	US 6,046,992 A (MEIER et al) 4 APRIL 2000, col. 2, line 58-col. 17, line 30.	1-13
A	US 5,530,963 A (MOORE et al) 25 June 1996, col. 3, line 52-col. 21, line 17.	1-13
<input type="checkbox"/> Further documents are listed in the continuation of Box C. <input type="checkbox"/> See patent family annex.		
* Special categories of cited documents:	"T"	later document published after the international filing date or priority date and not in conflict with the application but cited to understand the principle or theory underlying the invention
"A" document defining the general state of the art which is not considered to be of particular relevance	"X"	document of particular relevance; the claimed invention cannot be considered novel or cannot be considered to involve an inventive step when the document is taken alone
"E" earlier document published on or after the international filing date	"Y"	document of particular relevance; the claimed invention cannot be considered to involve an inventive step when the document is combined with one or more other such documents, such combination being obvious to a person skilled in the art
"L" document which may throw doubts on priority claim(s) or which is cited to establish the publication date of another citation or other special reason (as specified)	"&"	document member of the same patent family
"O" document referring to an oral disclosure, use, exhibition or other means		
"P" document published prior to the international filing date but later than the priority date claimed		
Date of the actual completion of the international search	Date of mailing of the international search report	
11 JUNE 2003	11 JUL 2003	
Name and mailing address of the ISA/US Commissioner of Patents and Trademarks Box PCT Washington, D.C. 20231 Facsimile No. (703) 305-3230	Authorized officer  T. RUPSTAS Telephone No. 703-305-2655	