

(21) Application No: 1711354.9
(22) Date of Filing: 14.07.2017
(30) Priority Data:
(31) 1612364 (32) 15.07.2016 (33) GB

(51) INT CL:
E04G 5/14 (2006.01) E04G 5/00 (2006.01)
E04G 21/32 (2006.01)

(56) Documents Cited:
GB 2539375 A GB 2484395 A
GB 2477812 A EP 1878850 A2
WO 2006/122763 A1 JP 2013213373 A

(71) Applicant(s):
Simcol Holdings Limited
(Incorporated in the United Kingdom)
35 & 35A Hermitage Way,
Hermitage Lane Industrial Estate, MANSFIELD,
Nottinghamshire, NG18 5ES, United Kingdom

(58) Field of Search:
INT CL E04G
Other: WPI, EPODOC

(72) Inventor(s):
Paul Graham Colley

(74) Agent and/or Address for Service:
Howard Lock Intellectual Property
Westthorpe Business Innovation Centre,
Westthorpe Fields Business Park, Killamarsh,
SHEFFIELD, S21 1TZ, United Kingdom

(54) Title of the Invention: **Connector**
Abstract Title: **Connector for a fall prevention barrier**

(57) A connector 10 for connecting a fall prevention barrier 100 to a support 102 comprises a main portion 12 and a securing portion 34 for securing the connector to the support. A holding member 14 is provided for holding a horizontal elongate article, such as a rail 30, and a carrying member 18 is provided for carrying the fall prevention barrier. The main portion may be elongate and substantially planar. The securing portion may be tubular, and may be V- or U-shaped. A fastener 38 may be provided to fix the support to the connector. The holding portion may be L-shaped and may include an aperture 40 through which the support can extend. The carrying member may comprise a hook extending from the main portion. The connector may comprise a pair of holding members and a pair of carrying members, and the or each holding member may include an aperture through which the support can extend.

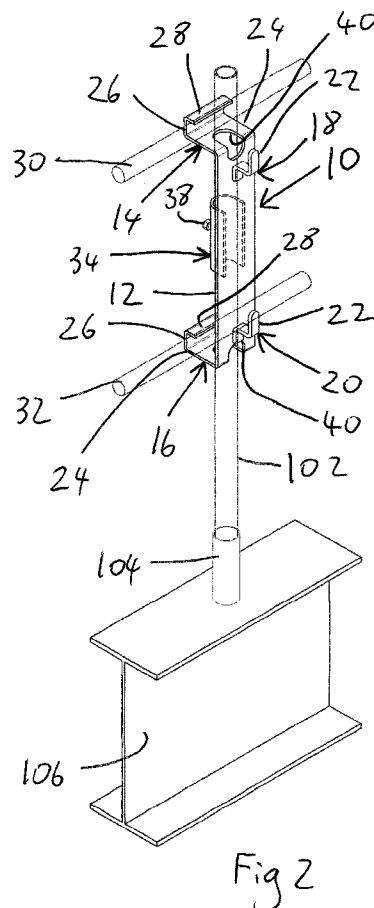

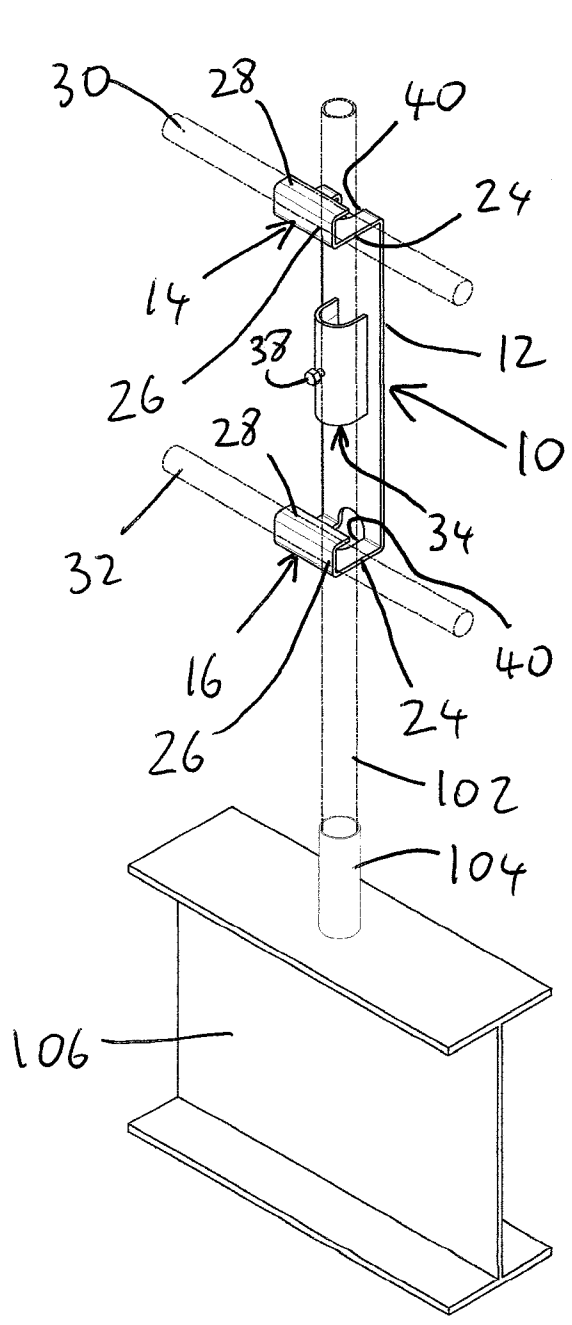

Fig 1

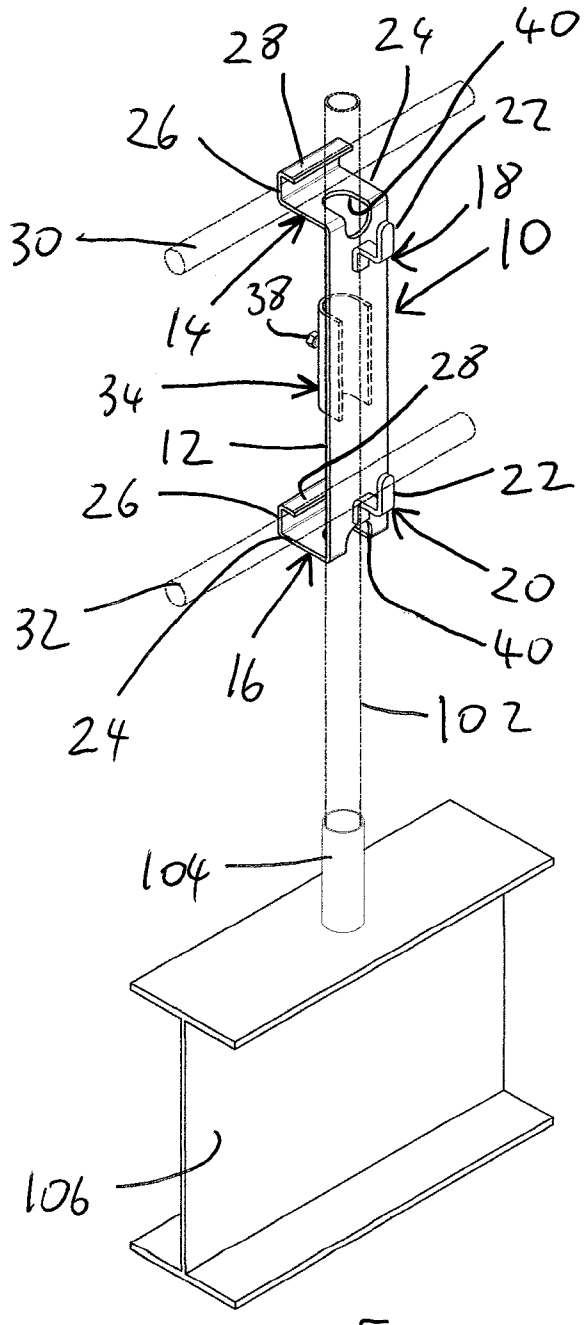
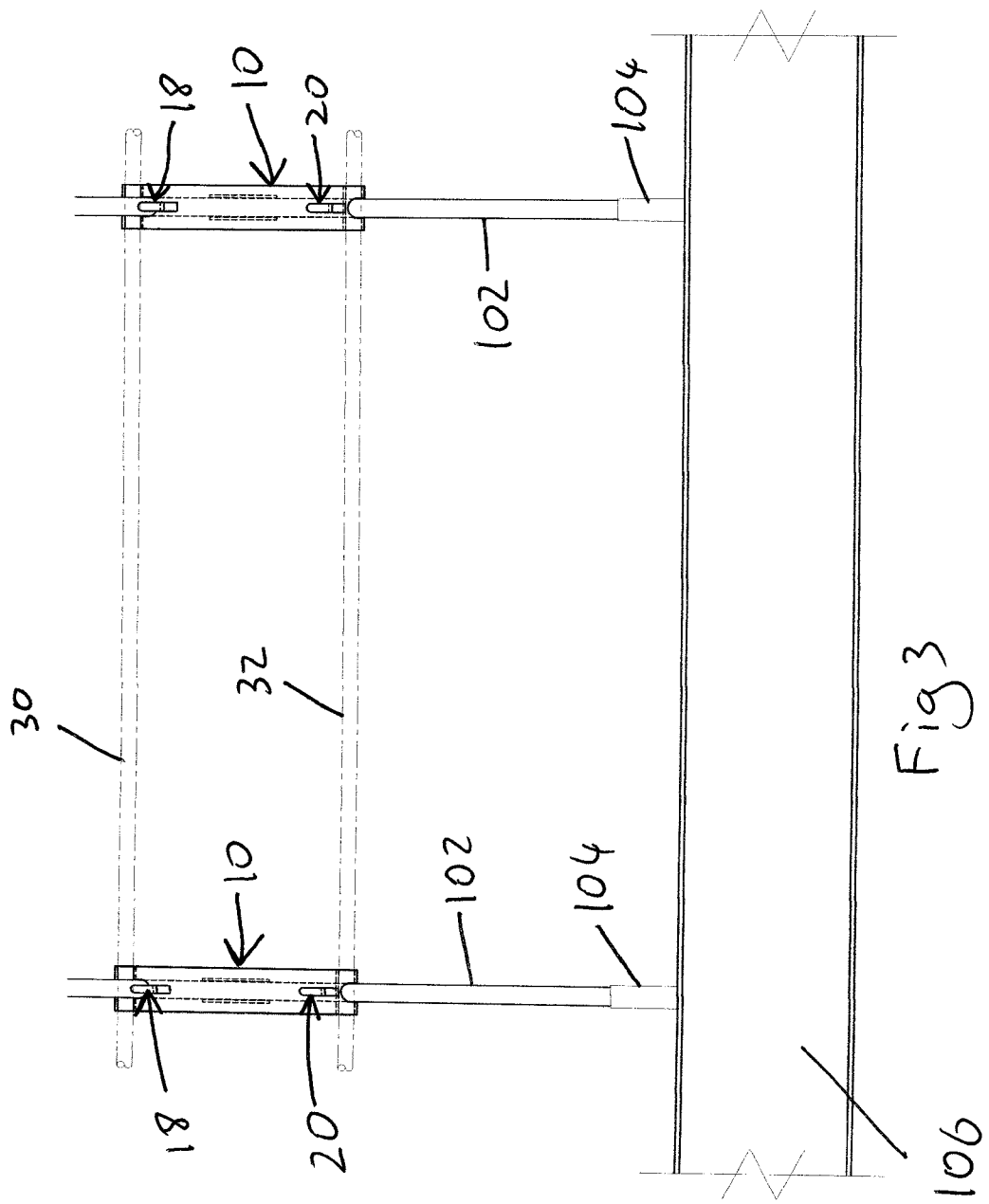

Fig 2



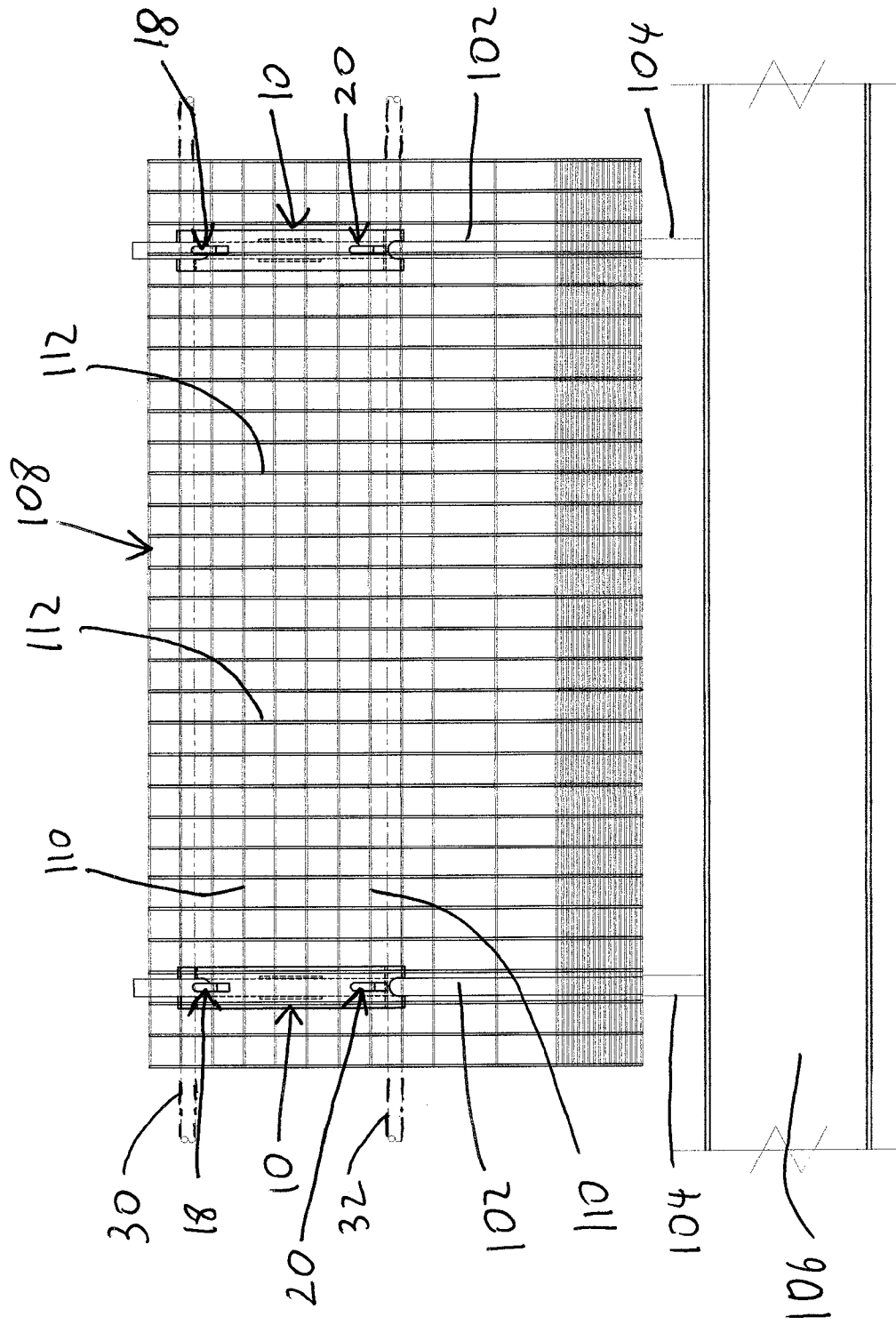
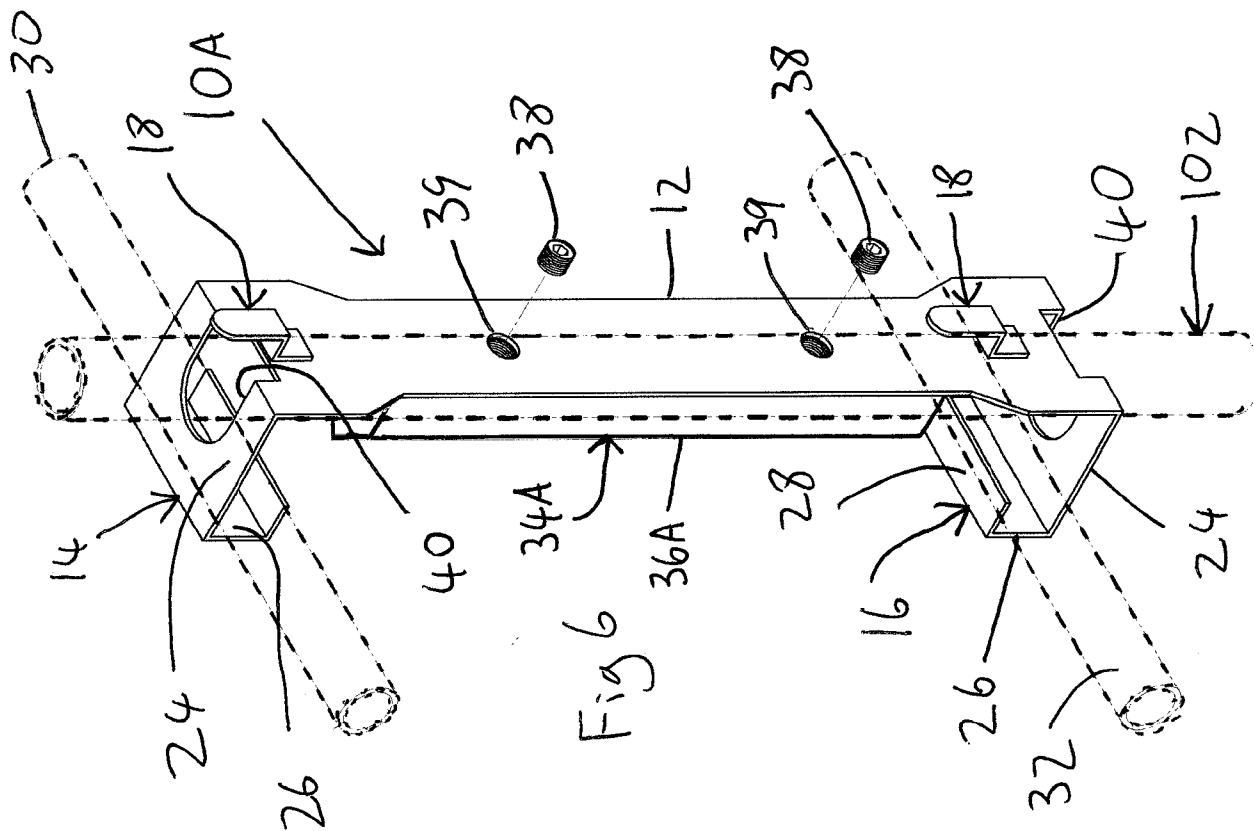
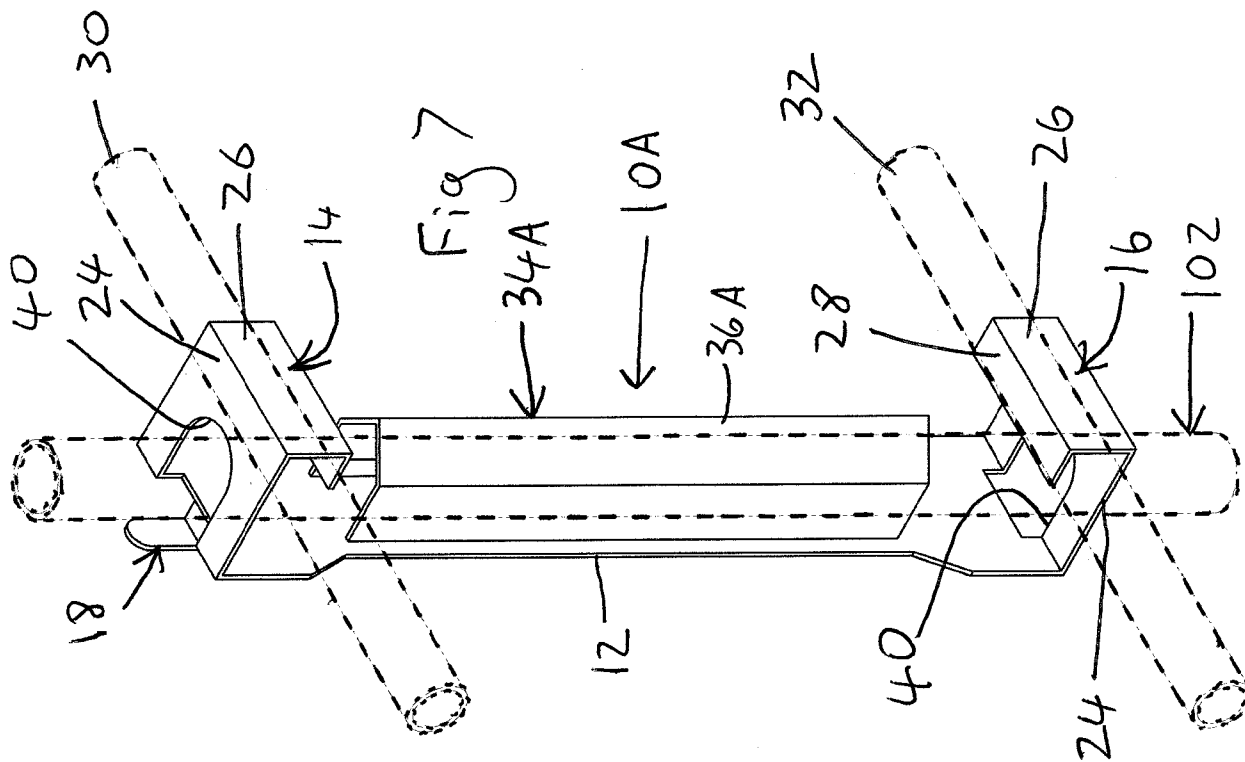

Fig 4



CONNECTOR

This invention relates to connectors. More particularly, but not exclusively, this invention relates to connectors for connecting fall prevention barriers to posts. This
5 invention may also relate to methods of connecting fall prevention barriers to posts.

During the construction of building, particularly tall buildings, it is necessary to provide a fall prevention system adjacent the edge of the building. Known fall prevention
10 systems comprise a plurality of upright posts and a plurality of fall prevention barriers on the posts. Connectors are provided to connect the barriers to the posts.

According to one aspect of this invention, there is provided a connector for connecting a fall prevention barrier to a support, the connector comprising: a main portion; a
15 securing portion for securing the connector to the support, the securing portion being provided on the main portion, wherein the securing portion is configured to receive the support therethrough; a holding member for holding a horizontal elongate article; and a carrying member for carrying the fall prevention barrier.

According to another aspect of this invention, there is provided a method of connecting
20 a fall prevention barrier to a support, wherein the method comprises providing a connector as described in the immediately preceding paragraph, securing the connector to the support by means of the securing portion, arranging an elongate article in the holding member so that said elongate article is held by the holding member, and arranging a fall prevention barrier on the carrying member so that said
25 fall prevention barrier is carrying by the carrying member.

The support may comprise a post. The main portion may be elongate. In use the main portion may extend along the support. The main portion may be substantially planar. The securing portion may be tubular. The securing portion may be elongate
30 and may extend along the main portion. In use the securing portion may extend along the support. The method may include the step of arranging the connector on the support so that the support is received through the securing portion.

The securing portion and the main portion may define a space in which the support can be received. In one embodiment, the securing portion may comprise a substantially U shaped member, which may be elongate. In another embodiment, the securing portion may comprise a substantially V shaped member.

5

The main portion may have first and second ends. The first end may be an upper end of the main portion. The second end may be a lower end of the main portion.

At least one fastening member may be provided to fasten the support to the connector.

10 The, or each, fastening member may comprise a bolt.

In one embodiment, the fastening member may extend through the securing portion to engage the support and secure the support to the connector. The fastening member may be arranged to press the support against the main portion. The fastening member
15 may include cooperating formations to cooperate with corresponding formations on the securing portion. The method may comprise screwing the fastening member into the securing portion to engage the support.

In another embodiment, the fastening member may extend through the main portion
20 to engage the support and secure the support to the connector. The fastening member may be arranged to press the support against the securing portion. The fastening member may include cooperating formations to cooperate with corresponding formations on the main portion. The method may comprise screwing the fastening member into the main portion to engage the support.

25

The connector may comprise first and second of the holding members to hold respective horizontal articles. The first of the holding members may be provided towards, or at, the first end of the main portion. The first holding member may be an upper holding member. The second of the holding members may be provided
30 towards, or at, the second end of the main portion. The second holding member may be a lower holding member.

The method may comprise the step of inserting the, or each, elongate article through the, or a respective, holding member. The step of inserting the, or each, elongate

article may comprise inserting the, or each, elongate article lengthwise into the, or a respective, holding member.

5 The holding member, or each of the first and second holding members, may comprise an L shaped portion having a first and second arms, the first arm being attached to the main portion, and the second arm being attached to the first arm.

10 The second arm may extend transverse to the first arm. The second arm may extend upwardly from the first arm. The second arm may have an edge spaced from the first arm.

15 A lip portion may be provided on said edge. The lip portion may extend across the first arm. In use, the lip portion may extend over the elongate article to prevent inadvertent removal thereof.

The, or each, holding member may define an aperture through which the support can extend. The first arm of the, or each, holding member may define the aperture.

20 The connector may include a further fastening member extending through the, or each, holding member to engage the horizontal article and urge the horizontal article against the support. The further fastening member may include cooperating formations to cooperate with corresponding formations on the, or each, holding member. The further fastening member may comprise a bolt.

25 The connector may comprise first and second of the carrying members to carry the fall prevention barrier. The first of the carrying members may be provided towards, or at, the first end of the main portion. The first carrying member may be an upper carrying member. The second of the carrying members may be provided towards, or at, the second end of the main portion. The second carrying member may be a lower carrying member.
30

The carrying member, or each of the first and second carrying members, may comprise a hook member extending from the main portion. The, or each, carrying

member may extend from the main portion in the opposite direction to the, or each, holding member.

5 The method may comprise arranging the fall prevention barrier so that one, or a respective, portion thereof is received by the, or each, hook member. The fall prevention barrier may comprise a plurality of elongate horizontal bars. The method may comprise arranging one, or a respective bar in the, or each, carrying member.

10 At least one embodiment of the invention will now be described with reference to the accompanying drawings, in which:

Figure 1 is a rear perspective view of a connector secured to a support, the connector holding two horizontal articles;

15 Figure 2 is a front perspective view of the connector shown in Figure 1;

Figure 3 is a front view of two connectors secured to respective supports;

20 Figure 4 is a front view of the connectors shown in Figure 1, with a fall prevention barrier in a lower position on the connectors;

Figure 5 is a front view of the connectors shown in Figure 1, with a fall prevention barrier in a raised position on the connectors;

25 Figure 6 is a front perspective view of a further connector secured to a support, the connector holding two horizontal articles; and

Figure 7 is a front perspective view of the connector shown in Figure 6.

30 Figures 1 and 2 show a connector 10 for carrying a fall prevention barrier 100 (see Figures 4 and 5) at the edge of a building. The connector 10 comprises an elongate substantially flat main portion 12 and upper and lower holding members 14, 16 on the main portion 12.

The main portion 12 and the upper and lower holding members 14, 16 are formed from a single piece of metal, such as steel. The upper and lower holding members 14, 16 are formed by pressing them from said single piece.

5 The connector 10 further includes upper and lower carrying members in the form of upper and lower hook members 18, 20 on the main portion 12. The upper and lower hook members 18, 20 extend from the main portion 12 in the opposite direction to the upper and lower holding members 14, 16.

10 Each of the upper and lower hook members 18, 20 comprises a hook member 22 extending from the main portion 12. The hook members 18, 20 carrying the fall prevention barrier 100 as explained below.

Each of the holding members 14, 16 comprises an L shaped portion 24 having a first
15 arm 24 extending from the main portion 12, and a second arm 26 extending upwardly from the first arm 24. Each holding member 14, 16 further includes a lip portion 28 extending from an edge of the second arm 26 over the first arm. The upper and lower holding members 14, 16 hold upper and lower elongate horizontal articles in the form of upper and lower rails 30, 32, as explained below.

20 The connector 10 further includes a securing portion 34 on the main portion 12. In one embodiment, the securing portion 34 comprises an elongate substantially U shaped member 36 attached to the main portion 12. The connector 10 is secured to a support in the form of a post 102. In use, the post 102 extends through the securing
25 portion 34. A fastener in the form of a bolt 38 is screwed into a threaded hole in the substantially securing portion 34 to engage the post 102 and press the post 102 against the main portion 12, thereby securing the connector 10 to the post 102.

Each of the first arms 24 of the upper and lower holding members 14, 16 defines an
30 aperture 40 through which the post 102 extends when the post 102 is secured to the connector 10.

In use, a cylindrical pot 104 is attached to a beam 106. The post 102 can be received into the pot 104 via an upper opening. The connector 10 is then secured to the post

102 by sliding the securing portion 34 over the post 102, so that the post 102 is received through the substantially securing portion 34 in the space defined between the securing portion 34 and the main portion 12. In this position, the post 102 extends through the apertures 40 in the upper and lower holding members 14, 16. The bolt 38 is then tightened against the post 102 to secure the connector 10 to the post 102.

The upper and lower rails 30, 32 are then slid through the upper and lower holding members 14, 16 between the lip portion 28 and the first arm 14 of each holding member 14, 16. As shown in Figure 3, a plurality of posts 102 are mounted on the beam 106 in respective pots 104. A respective connector 10 is secured to each post 102.

The rails 30, 32 extend through the holding members 14, 16 of each connector 10. Thus, the rails 30, 32 extend across the connectors 10 on each post 102. In Figure 3, only two of the posts 102 are shown on the beam 106, but it will be appreciated that any suitable number of the posts 102 can be mounted on the beam 106.

Figure 4 shows a fall prevention barrier 108 connected to the posts 102 shown in Figure 2. The fall prevention barrier 108 is formed of a mesh of horizontal and vertical bars 110, 112.

The fall prevention barrier 108 is connected to the posts 102 by arranging the fall prevention barrier 108 so that one of the horizontal bars 110 is received by the upper hook members 18 and a lower one of the horizontal bars 110 is received by the lower hook members 20. Thus, the fall prevention barrier 108 can be arranged on the connectors 10 in a plurality of vertical positions by selecting which of the horizontal bars 110 are received in the upper and lower hook members 18, 20. For example, Figure 5 shows a view similar to Figure 4, in which the fall prevention barrier 108 is in a raised position relative to the position shown in Figure 4.

There is thus described a connector 10 for connecting a fall prevention barrier 108 to a plurality of posts 102 for use at an edge of a building.

Various modifications can be made without departing from the scope of the invention.

A further embodiment of the connector, generally designated 10A, is shown in Figures 6 and 7. The connector 10A includes many of the features of the connector 10 shown in Figures 1 to 5. The features of the connector 10A that are also present in the connector 10 have been designated with the same reference numerals in Figures 6 and 7 as the reference numerals designating the corresponding features in Figures 1 to 5.

The connector 10A differs from the connector 10 in that the connector 10A includes a securing portion 34A in the form of a substantially V shaped member 36A. A further difference is that two bolts 38 are screwed into two threaded holes 39 in the main portion 12. The post 102 is received in the space defined between the securing portion 34A and the main portion 12. The bolts 38 are screwed into the holes 39 in the main portion 12 to engage the post 102. The post 102 is secured to the connector 10A by tightening the bolts 38 against the post 102, thereby pressing the post 102 against the securing portion 34A.

Claims

1. A connector for connecting a fall prevention barrier to a support, the connector comprising: a main portion; a securing portion for securing the connector to the support, the securing portion being provided on the main portion, wherein the securing portion is configured to receive the support therethrough; a holding member for holding a horizontal elongate article; and a carrying member for carrying the fall prevention barrier.
2. A connector according to claim 1, wherein the main portion is elongate so that the main portion can extend along the support.
3. A connector according to claim 1 or 2, wherein the main portion is substantially planar.
4. A connector according to claim 1, 2 or 3, wherein the securing portion is tubular and elongate and extends along the main portion, whereby in use the securing portion extends along the support.
5. A connector according to any preceding claim, wherein the securing portion and the main portion define a space in which the support can be received.
6. A connector according to any preceding claim, wherein the securing portion comprises an elongate substantially U shaped or V shaped member.
7. A connector according to any preceding claim, wherein at least one fastening member is provided to fasten the support to the connector.
8. A connector according to claim 7, wherein the fastening member extends through the securing portion to engage the support and secure the support to the connector, the fastening member being arranged to press the support against the main portion.

9. A connector according to claim 7, wherein the fastening member extends through the main portion to engage the support and secure the support to the connector, the fastening member being arranged to press the support against the securing portion.

5

10. A connector according to any preceding claim, comprising first and second of the holding members to hold respective horizontal articles, the first of the holding members being provided towards, or at, a first end of the main portion, and the second of the holding members being provided towards, or at, a second end of the main portion.

10

11. A connector according to any preceding claim, wherein the, or each holding member comprises an L shaped portion having a first and second arms, the first arm being attached to the main portion, and the second arm being attached to the first arm.

15

12. A connector according to claim 11, wherein the second arm extends transverse to the first arm, and the second arm has an edge spaced from the first arm, and wherein a lip portion is provided on said edge, the lip portion extending across the first arm.

20

13. A connector according to any preceding claim, wherein the, or each, holding member defines an aperture through which the support can extend.

14. A connector according to claim 13 when dependent upon claim 11 or 12, wherein the first arm of the, or each, holding member may define the aperture.

25

15. A connector according to any preceding claim, wherein comprising first and second of the carrying members to carry the fall prevention barrier, the first of the carrying members being provided towards, or at, the first end of the main portion, and the second of the carrying members being provided towards, or at, the second end of the main portion.

30

16. A connector according to any preceding claim, wherein the, or each carrying member comprises a hook member extending from the main portion, the, or each,

carrying member extending from the main portion in the opposite direction to the, or each, holding member.

5 17. A method of connecting a fall prevention barrier to a support, wherein the method comprises providing a connector as described in the immediately preceding paragraph, securing the connector to the support by means of the securing portion, arranging an elongate article in the holding member so that said elongate article is held by the holding member, and arranging a fall prevention barrier on the carrying member so that said fall prevention barrier is carrying by the carrying member.

10

18. A method according to claim 17, including the step of arranging the connector on the support so that the support is received through the securing portion.

15 19. A method according to claim 17 or 18, wherein at least one fastening member is provided to fasten the support to the connector, the fastening member including cooperating formations to cooperate with corresponding formations on the securing portion, and the method comprises screwing the fastening member into the securing portion to engage the support.

20 20. A method according to claim 17 or 18, wherein at least one fastening member is provided to fasten the support to the connector, the fastening member including cooperating formations to cooperate with corresponding formations on the main portion, and the method comprises screwing the fastening member into the main portion to engage the support.

25

21. A method according to any of claims 17 to 20, wherein the connector comprises first and second of the holding members to hold respective horizontal elongate articles, and the method comprises the step of inserting the, or each, elongate article through the, or a respective, holding member.

30

22. A method according to claim 21, wherein the step of inserting the, or each, elongate article comprises inserting the, or each, elongate article lengthwise into the, or a respective, holding member.

23. A method according to any of claims 17 to 22, wherein the connector comprises first and second of the carrying members to carry the fall prevention barrier, the, or each, carrying member, and the method comprises arranging the fall prevention barrier so that one, or a respective, portion thereof is received by the, or each, carrying member.

5

24. A method according to any of claims 17 to 23, wherein the fall prevention barrier comprises a plurality of elongate horizontal bars, and the method comprises arranging one, or a respective bar in the, or each, carrying member.

10



Application No: GB1711354.9

Examiner: Mr William Crowe

Claims searched: 1-24

Date of search: 21 December 2017

Patents Act 1977: Search Report under Section 17

Documents considered to be relevant:

Category	Relevant to claims	Identity of document and passage or figure of particular relevance
X	1-5, 7-10 and 15-24	EP1878850 A2 (COMBISAFE INTERNATIONAL) See Figures and Abstract, noting barrier support element comprising main portion 4, securing portion 6, holding members 8, 10 and carrying members 14, 16.
X	1, 2, 4, 5, 7, 11, 13-18 and 24	GB2477812 A (POULTON) See Figures, noting scaffolding tool comprising a main portion 15, securing portion 55, holding member 50 and carrying member 40.
X	1-3, 5, 7, 11, 16-18 and 24	JP2013213373 A (STEP UP KK) See Figure 2 and Abstract Accession Number 2013-R21080, noting scaffolding handrail support comprising main portion 8, securing portions 17, 18, holding member 13 and carrying member 16.
X	1-4, 6, 7, 11, 16-18 and 24	GB2484395 A (STEELHOARD LTD) See Figures, noting safety rail system comprising a main portion 14, securing portions 16a, 16b, holding member 20 and carrying member 22.
A,P	-	GB2539375 A (SRC CONSULTANCY) See Figures, noting scaffold safety apparatus comprising panel carrying members 19, 20.
A	-	WO2006/122763 A1 (COMBISAFE INTERNATIONAL) See Figures, noting safety barrier support comprising carrying members 15, 17.

Categories:

X	Document indicating lack of novelty or inventive step	A	Document indicating technological background and/or state of the art.
Y	Document indicating lack of inventive step if combined with one or more other documents of same category.	P	Document published on or after the declared priority date but before the filing date of this invention.
&	Member of the same patent family	E	Patent document published on or after, but with priority date earlier than, the filing date of this application.

Field of Search:

Search of GB, EP, WO & US patent documents classified in the following areas of the UKC^X :

Worldwide search of patent documents classified in the following areas of the IPC

E04G



The following online and other databases have been used in the preparation of this search report

WPI, EPODOC

International Classification:

Subclass	Subgroup	Valid From
E04G	0005/14	01/01/2006
E04G	0005/00	01/01/2006
E04G	0021/32	01/01/2006