

(19)  
(12)

(KR)  
(B1)

(51) 。 Int. Cl. <sup>7</sup>  
B01D 63/04

(45)  
(11)  
(24)

2002 10 11  
10 - 0354613  
2002 09 16

(21) 10 - 2000 - 0050644  
(22) 2000 08 30

(65) 2002 - 0017362  
(43) 2002 03 07

(73) 431 - 6 103 703

(72) 431 - 6 1 - 3 703

431 - 6 103 703

(74)  
:

(54) 가

(15)(25) (11)(12) (21)(22) (11)(12);  
(13) U 가 (13);  
(14) (11)(12) (13)

가 .

- 1 ,
- 2 ,
- 3 2 A - A ,
- 4 ,
- 5 .

\* \*

- 11, 12 : 13 :
- 14 : 15, 25 :
- 16 : 21, 22 :
- 26 : O - 31 - 33 :
- 34:

가

가

10 cm ,

가

가

가

d - end)

가

(dea

가

(11)(12); (13); (15)(25) (13) (11)(12) (21)(22) U 가  
 (13) (14) (11)(12) (11)(12)

6) (13) O- (26) (25) (1

(12) (13) (25) (11)

가 가

1 , 2

(11)(12), (13), (14) (11)(12)  
 (21)(22) (11)(12)  
 (Hole) (21)(22)  
 (15) (11)(12)

가 (13) (15)(25) (11)(12) U  
 (11) (13) (12) U

(13) (14) (13) (11)(12)  
 (13) (13) 가 가 가

(14) (13) U (13)  
 (13) 가 (14) (13)  
 (13) (13)

3 2 A - A

가

(13) O- (26) (25) (16)

(16) (25) (16) (13) (16) (13)

(15) (13) (25) (11)(12) (15)

(15)(25) (25) O- (26) (15) (15)

(25) (13) (15)(25) (11) (15)(25) (12) (15)

(15)(25) (13) (blind)

가 (25) (13) (一) (13)

(13) (15)(25) (13)

4 , 5

4 , (11)(12) (21)(22) 31 32 33 가 (

11)(12) (34) (34)가 가 (13)

5 , (13) 31 (34) (34) 가

32 (11) (13) (12) 32

(21) 4 (21)(22) (22) 5 (31 - 33)

3

(dead - end) 가 (cross -

flow) 가

가

가

가 .

가 ,

(57)

1.

(21)(22)

(11)(12);

(13); (15)(25) (11)(12) U 가

(14) (13) (11)(12) 가 (13)

2.

1 ,

가 (13) O- (26) (25) (16)

3.

2 ,

(13) (25) 가 (11)(12)

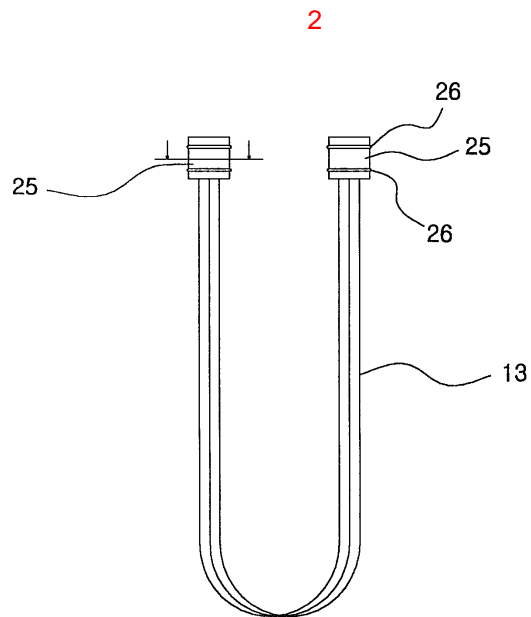
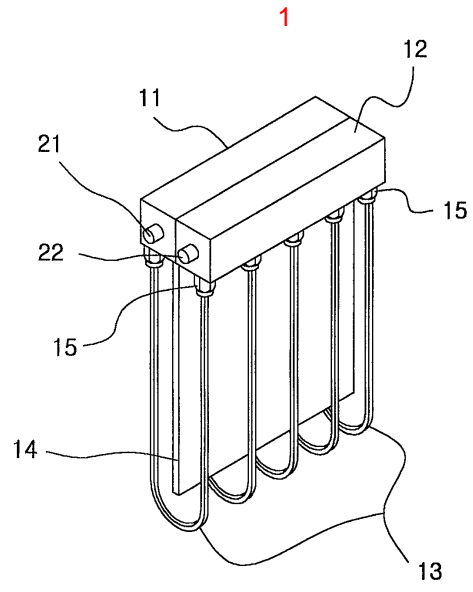

3

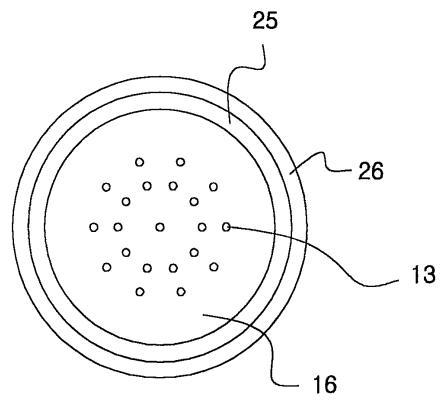

4

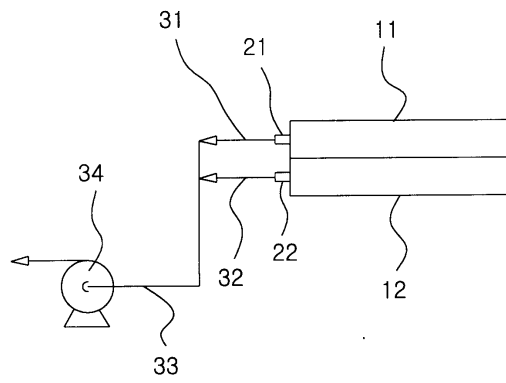

5

