

(19)



Europäisches Patentamt
European Patent Office
Office européen des brevets



(11)

EP 0 584 893 B1

(12)

EUROPEAN PATENT SPECIFICATION

(45) Date of publication and mention
of the grant of the patent:
03.12.1997 Bulletin 1997/49

(51) Int Cl.⁶: **G03G 15/16**

(21) Application number: **93203341.8**

(22) Date of filing: **17.04.1990**

(54) Image transfer apparatus and method

Bildübertragungsgerät und -verfahren

Appareil et méthode de transfert d'images

(84) Designated Contracting States:
DE FR GB IT

(30) Priority: **14.08.1989 US 393649**
14.08.1989 US 393631

(43) Date of publication of application:
02.03.1994 Bulletin 1994/09

(60) Divisional application: **97201407.0**

(62) Document number(s) of the earlier application(s) in
accordance with Art. 76 EPC:
90907505.3 / 0 487 530

(73) Proprietor: **INDIGO N.V.**
6229 GA Maastricht (NL)

(72) Inventors:
• **Landa, Benzion**
Edmonton, Alberta Canada T5K 1Y8 (CA)
• **Ashkenazi, Itzhak**
IL-76100 Rehovot (IL)
• **Van Mil, Jan**
IL-52100 Ramat Gan (IL)

- **Pinhas, Hanna**
IL-58100 Holon (IL)
- **Lior, Ishaiau**
IL-70400 Ness Ziona (IL)
- **Fenster, Paul**
IL-49100 Petach Tikva (IL)

(74) Representative: **de Bruijn, Leendert C. et al**
Nederlandsch Octrooibureau
P.O. Box 29720
2502 LS Den Haag (NL)

(56) References cited:
EP-A- 0 176 143 **EP-A- 0 318 078**
US-A- 4 708 460

- **FUJITSU-SCIENTIFIC AND TECHNICAL**
JOURNAL, vol.24, no.3, September 1988,
KAWASAKI JP pages 235 - 241 OGASAWARA ET
AL. 'High Quality Toner Image Transfer in
Electrophotographic Printing'

Remarks:

Divisional application 97201407.0 filed on 09/05/97.

EP 0 584 893 B1

Note: Within nine months from the publication of the mention of the grant of the European patent, any person may give notice to the European Patent Office of opposition to the European patent granted. Notice of opposition shall be filed in a written reasoned statement. It shall not be deemed to have been filed until the opposition fee has been paid. (Art. 99(1) European Patent Convention).

Description

FIELD OF THE INVENTION

5 The present invention relates to image transfer techniques and apparatus for use in liquid toner electrostatic imaging using an intermediate transfer member.

BACKGROUND OF THE INVENTION

10 The use of an intermediate transfer member in electrostatic imaging is well known in the art.
Various types of intermediate transfer members are known and are described, for example in U.S. Patents 3,862,848, 4,684,238, 4,690,539 and 4,531,825.

Belt-type intermediate transfer members for use in electrophotography are known in the art and are described, inter alia, in U.S. Patents 3,893,761, 4,684,238 and 4,690,539.

15 In both liquid and powder toner imaging systems employing intermediate transfer members it is known to heat the toner images on the intermediate transfer member before transfer to the final substrate. In U. S. Patent 4,708,460 a liquid toner image is heated by radiant heat from a heater external to the transfer member in order to evaporate the liquid carrier and to melt the solid toner before transfer. In U. S. Patent 4,518,976 there is described a belt image transfer system, wherein the belt is heated by a heating roller, provided at the back of the belt, during transfer from the belt to the final substrate. In U. S. Patent 4,585,319 a radiant heater in the center of a drum ITM is used to heat the ITM.

20 The use of intermediate transfer members is well known in the printing art. In offset printing an image formed of a viscous ink is transferred from a first drum to a second drum prior to transfer to the final substrate. It has been recognized that the pressures between the various drums and against the final substrate are important to the quality of the final print.

25 Two types of offset blankets are generally available, consistent with the ink characteristics. Conventional printing blankets are relatively stiff and have provided little leeway for packing error. Compressible blankets are made with varying compressibilities, with typical curves shown for example on page 33 of "Web Offset-Press Operating", published by Graphic Arts Technical Foundation, Pittsburgh, PA, 1984.

The pressures used in offset printing are generally not specified. However, pressures are indicated to be in the general vicinity of 100-150 lb./sq. in. in the above reference and in U. S. Patent 3,983,287.

30 European Patent Publication 0 176 143 A1 describes a powder toner copying machine utilizing an intermediate transfer member in which the pressure and deformation at first transfer is less than at second transfer.

Japanese patent publication 62-134673 describes a powder toner imaging system utilizing an intermediate transfer member in which the pressure is greater at second transfer than at first transfer.

35 U.S. Patent 4,912,514 describes a powder toner imaging system having a heated intermediate transfer belt where, in one embodiment the heater is formed of elongate elements and the belt includes a silicone rubber layer.

U.S. Patent 4,708,460 describes a liquid toner imaging system in which an intermediate transfer member is used.

SUMMARY OF THE INVENTION

40 The present invention seeks to provide apparatus and techniques for improved electrostatic image transfer using an intermediate transfer member.

There is therefore provided an imaging system including

- 45 an image bearing surface;
- apparatus for forming a toner image on the image bearing surface;
- an intermediate transfer member operative for transfer of the toner image from the image bearing surface to a substrate;
- apparatus for providing first transfer engagement between the intermediate transfer member and the image bearing surface for transfer of the toner image from the image bearing surface to the intermediate transfer member at a first pressure, producing deformation of the intermediate transfer member to a first deformation degree;
- 50 apparatus for providing second transfer engagement between the intermediate transfer member and the substrate for transfer of the toner image from the intermediate transfer member to the substrate at a second pressure, producing deformation of the intermediate transfer member to a second deformation degree, characterized in that:
- 55 the toner image is a liquid toner image; and
- the ratio of the second pressure to the first pressure is substantially greater than the ratio of the second deformation degree to the first deformation degree.

In a preferred embodiment of the invention the intermediate transfer member comprises a conductive layer operative to apply an electric field to the image to enhance transfer of the liquid toner image from the image bearing surface to the intermediate transfer member.

5 Preferably the intermediate transfer member comprises a blanket heater operative to heat the liquid toner image thereon prior to the second transfer engagement.

In a preferred embodiment of the invention the first and second pressures are substantially constant along lines in the axial direction upon the first and second transfer engagements on the intermediate transfer member, and wherein the heater is formed of thin wires along the lines.

10 In a further preferred embodiment of the invention the intermediate transfer member comprises:

- an outward facing transfer surface;
- a compressible layer;
- a backing layer; and
- 15 a heating layer disposed intermediate the backing layer and the transfer surface.

Preferably, the intermediate transfer member comprises a second compressible layer, the heating layer being preferably disposed intermediate the compressible layer and the second compressible layer.

In a preferred embodiment of the invention the intermediate transfer member comprises a resilient layer and a compressible layer and preferably includes an area heater disposed between the resilient and compressible layers.

20 There is further provided in a preferred embodiment of the invention imaging apparatus including:

- an image bearing surface; and
- an intermediate transfer member having an image transfer surface and being operative for transfer of a toner image from the image bearing surface to the image transfer surface for subsequent transfer therefrom to a second surface, characterized in that the intermediate transfer member comprises:
 - 25 a transfer surface for operative engagement with the image bearing surface;
 - a resilient layer;
 - a sponge layer which is softer than the resilient layer; and
 - an area heater disposed between the relatively compliant sponge layer and the resilient layer.

30 Preferably the intermediate transfer member comprises a conductive layer operative to apply an electric field to the toner image to enhance transfer of the toner image from the image bearing surface to the intermediate transfer member.

35 In a preferred embodiment of the invention, the imaging apparatus includes:

- apparatus for providing first transfer engagement between the intermediate transfer member and the image bearing surface for transfer of an image from the image bearing surface to the intermediate transfer member at a first pressure; and
- 40 apparatus for providing second transfer engagement between the intermediate transfer member and the substrate for transfer of the image from the intermediate transfer member to the second surface at a second pressure, wherein the first and second pressure is substantially constant along axial lines on the intermediate transfer member upon the first and second transfer engagements, and wherein the heating layer is formed of thin wires disposed along the lines.

45 Preferably, the heating layer is energized by alternating current and the thin wires are arranged in adjoining pairs, each pair comprising first and second wires, the voltage on the first wire of a pair being substantially equal and of opposite sign to that of the second wire of the pair relative to a reference voltage, wherein the reference voltage is preferably ground.

In a preferred embodiment of the invention the compressible layer has a thickness of about 300 micrometers.

50 Preferably, the heating layer is disposed intermediate the compressible layer and the transfer surface.

There is further provided in a preferred embodiment of the invention imaging apparatus comprising:

- a drum having an image bearing surface;
- apparatus for forming a toner image on the image bearing surface;
- 55 an intermediate transfer member operative for transfer of the toner image from the image bearing surface to a transfer surface of the intermediate transfer member and for subsequent transfer to a substrate, characterized in that the intermediate transfer member comprises a rigid core and an intermediate transfer blanket removably attached to the core.

In an preferred embodiment of the invention the toner image is a liquid toner image.

There is further provided, in a preferred embodiment of the invention an intermediate transfer blanket for the transfer of a toner image from a first surface to a second surface and comprising:

- 5 a transfer surface for operative engagement with the first and second surfaces;
- a resilient layer;
- a sponge layer which is softer than the resilient layer; and
- an area heater disposed between the relatively compliant sponge layer and the resilient layer.

10 In a preferred embodiment of the invention the resilient layer is situated between the heater and the transfer surface.

BRIEF DESCRIPTION OF THE DRAWINGS

15 The present invention will be understood and appreciated more fully from the following detailed description, taken in conjunction with the drawings in which:

- Fig. 1 is a simplified sectional illustration of electrostatic imaging apparatus constructed and operative in accordance with a preferred embodiment of the present invention;
- 20 Fig. 2 is a simplified sectional illustration of electrostatic imaging apparatus constructed and operative in accordance with another preferred embodiment of the present invention;
- Fig. 3A is a simplified, conceptual, sectional illustration of an intermediate transfer member constructed and operative in accordance with a preferred embodiment of the present invention;
- Fig. 3B is a simplified, conceptual, sectional illustration of a portion of a preferred embodiment of the intermediate transfer member of Fig. 3A;
- 25 Fig. 3C is a simplified, conceptual, sectional illustration of a portion of a second preferred embodiment of the intermediate transfer member of Fig. 3A;
- Fig. 3D is an illustration of a preferred heater for the intermediate transfer member;
- Fig. 3E is a detailed illustration of a portion of the heater of Fig. 3D;
- Fig. 3F is an illustration of another preferred heater for the intermediate transfer member;
- 30 Fig. 3G is a detailed illustration of a portion of the heater of Fig. 3F;
- Fig. 3H is a detailed illustration of a portion of an alternative to that of Fig. 3F;
- Fig. 3I is an illustration of another preferred heater for the intermediate transfer member;
- Fig. 4 is a simplified sectional illustration of the manufacture of part of the apparatus of Figs. 3A and 3B;
- Fig. 5 is a graphical illustration of the relationship between pressure and deformation of the apparatus of Fig. 3B;
- 35 and
- Fig. 6 is a schematic illustration of a preferred circuit for energizing the heaters of Figs. 3F-3I.

DETAILED DESCRIPTION OF PREFERRED EMBODIMENTS

40 Reference is now made to Fig. 1, which illustrates electrostatic imaging apparatus constructed and operative in accordance with a preferred embodiment of the present invention. This and other embodiments of the invention are described by way of example for apparatus utilizing liquid toner with negatively charged toner particles, and for a write-white system. For positively charged toner particles and/or for a write-black system the magnitudes and or the polarities of the voltages may be adjusted as is well known in the art. In a preferred embodiment of the invention the toner of
 45 Example 1 of U.S. Patent 4,794,651 is employed, but a variety of liquid toner types may be used in the practice of the invention.

As in conventional electrophotographic systems, the apparatus of Fig. 1 comprises a drum 10 arranged for rotation about an axle 12 in a direction generally indicated by arrow 14. The drum 10 is formed with a cylindrical photoconductor surface 16.

50 A corona discharge device 18 is operative to generally uniformly charge the photoconductor surface 16 with a positive charge. Continued rotation of the drum 10 brings the charged photoconductor surface 16 into image receiving relationship with an exposure unit including a lens 20, which focuses a desired image onto the charged photoconductor surface 16, there by selectively discharging the photoconductor surface and producing an electrostatic latent image thereon. Lens 20 may be the lens of a photocopier, as illustrated. Alternatively the latent image may be formed by a
 55 laser scanner.

Continued rotation of the drum 10 brings the charged photoconductor surface 16 bearing the electrostatic latent image into operative association with a development unit 22, including development electrodes 24, which is operative to apply a liquid developer comprising carrier liquid and toner particles to the photoconductor surface to develop the

electrostatic latent image thereon.

In accordance with a preferred embodiment of the invention, following application of toner to photoconductor surface 16, photoconductor surface 16 passes a typically positively charged, rotating roller 26, preferably rotating in a direction indicated by an arrow 28. Typically the spatial separation of the roller 26 from the photoconductor surface 16 is about 50 microns.

Preferably, the voltage on roller 26 is intermediate the voltages of the latent image areas and of the background areas on the photoconductor surface 16. Typical voltages are: roller 26: +300 to +500 V, background area: +50 V and latent image areas: up to +1000 V.

It is appreciated that roller 26, rotating in the direction indicated by arrow 28, functions as a metering roller and reduces the thickness of liquid carrier on the photoconductor surface 16, as is known in the art.

In any event, the photoconductor surface 16, after passing the roller 26, should be relatively free of pigmented toner particles except in the region of the latent image.

Downstream of roller 26 there is preferably provided a rigidizing roller 30. Rigidizing roller 30 is preferably formed of a resilient polymeric material, such as the conductive resilient polymeric materials described in either or both of U. S. Patents 3,959,574 and 3,863,603. Roller 30 is preferably maintained in contacting and preferably pressured relationship with the photoconductor surface 16.

In a preferred embodiment of the invention, the biased squeegee described in U. S. Patent 4,286,039 is used as the roller 30. A negative voltage of about 1000 to 2000 Volts, preferably about 1500 Volts (for a write-white system), is maintained on the squeegee. A corona discharge takes place and a current of approximately 50 - 100 microamperes for a drum width of 30 cm, flows from the squeegee. Roller 30 repels negatively charged pigmented toner particles and causes them to more closely approach the image areas of the photoconductor surface 16, thus compressing and rigidizing the toner image thereon.

Downstream of rigidizing roller 30 there is provided an intermediate transfer member 40, which rotates, as shown by arrow 41, in a sense opposite to that of drum 10, and is operative for receiving the toner image from surface 16 and for transferring the toner image to a receiving substrate 42, such as paper, which is supported by a roller 43.

In accordance with a preferred embodiment, a particular feature of the invention is that intermediate transfer member 40 is configured and mounted with respect to drum 10 so as to provide first transfer engagement between intermediate transfer member 40 and image bearing photoconductor surface 16 for transfer of an image from surface 16 to the intermediate transfer member 40 at a first pressure, thereby producing radial deformation of the intermediate transfer member to a first deformation degree.

The configurations and arrangements of intermediate transfer member 40, substrate 42 and roller 43 are preferably such as to provide second transfer engagement between intermediate transfer member 40 and substrate 42 for transfer of the image from intermediate transfer member 40 to substrate 42 at a second pressure, which exceeds the first pressure by a first multiple, producing radial deformation of the intermediate transfer member to a second deformation degree which exceeds the first deformation degree by a second multiple substantially less than the first multiple.

Additionally in accordance with a preferred embodiment of the present invention there is provided an intermediate transfer member characterized in that deformation thereof increases less than linearly with the application of increased pressure thereto. The structure of intermediate transfer members in accordance with preferred embodiments of the invention is described hereinbelow in detail.

Transfer of the image to intermediate transfer member 40 is preferably facilitated by providing electrification of the intermediate transfer member 40 to a voltage opposite that of the charged particles, although other methods known in the art may be employed. Subsequent transfer of the image to substrate 42 is preferably facilitated by heat and pressure, although other methods known in the art may be employed.

It has been noted that when the negatively biased squeegee roller of U.S. Patent 4,286,039, with high negative voltage, is utilized as the roller 30, the positive voltage on the intermediate transfer member required to transfer the image thereto is sharply reduced, typically from about 1000 volts or more to about 500 to 600 volts or less. It is believed that this reduction is possibly due to a discharge of the charges in the image area of the photoconductor surface 16 by current from the squeegee roller.

Following transfer of the toner image to the intermediate transfer member, the photoconductor surface 16 is engaged by a cleaning roller assembly 50, including a pair of rollers 52, which typically rotate in opposite directions, and a nozzle 54. Cleaning roller assembly 50 is operative to scrub and clean surface 16. A cleaning material, such as liquid developer, may be supplied to the assembly 50 via nozzle 54. A suitable cleaning assembly is shown and described in U.S. Patent 4,439,035. Any residual charge left on the photoconductor surface 16 may be removed by flooding the photoconductor surface 16 with light from a lamp 58.

Reference is now made to Fig. 2 which illustrates electrophotographic imaging apparatus constructed and operative in accordance with another preferred embodiment of the present invention. The apparatus of Fig. 2 shares many common elements with that of Fig. 1. These elements are indicated by identical reference numerals, and for the sake of conciseness are not described herein a second time.

The embodiment of Fig. 2 differs from that of Fig. 1 in that a belt-type intermediate transfer member 70 is employed instead of the roller type member 40 in the embodiment of Fig. 1. Belt-type intermediate transfer members are well known in the art and are described, inter alia, in U.S. Patents 3,893,761, 4,684,238 and 4,690,539.

Intermediate transfer member 70 is preferably charged so as to provide electrophoretic transfer thereto of the image from the photoconductor surface 16. The efficiency of electrophoretic transfer of the image is generally enhanced by increasing the potential difference between photoconductor surface 16 and intermediate transfer member 70. Increase in the potential difference between the photoconductor surface 16 and the intermediate transfer member 70 is limited, however, by the danger of severe electrical breakdown, which increases with an increase in potential difference.

Reference is now made to Fig. 3A which conceptually illustrates an intermediate transfer member 40 comprising a drum 80 having a generally cylindrical surface over which is tensioned a multi-layer intermediate transfer blanket 82, which is supported and tensioned by a blanket lockup mechanism 84. The electrical connections to the various voltage bearing portions of intermediate transfer blanket 82 are not shown, it being understood that they are achieved in a conventional manner using rotating contacts.

A preferred embodiment of multi-layer intermediate transfer blanket 82 is illustrated in Fig. 3B and comprises a substrate (backing layer) 90 with high temperature capabilities, preferably formed of Kapton (DuPont) polyimide film of thickness about 100 microns. Over the substrate 90 there is provided a blanket heater 92 preferably comprising a meandering ribbon conductor of Nichrome (Trademark ; an alloy of Driver Harris Org.) in a sandwich of Kapton. Blanket heater 92 has a total thickness of about 250 microns.

Normally one surface of blanket heater 92 has a slightly raised pattern due to the presence of the ribbon. Accordingly, it is preferable to arrange the blanket heater 92 such that the surface having the slightly raised pattern lies facing substrate 90.

Blanket heater 92, in conjunction with the rest of the intermediate transfer blanket 82, operates to improve transfer of the image to the final substrate by heating the toner image. When a liquid toner for which the particles solvate the carrier at a temperature below the melting point of the toner particles is utilized in the practice of the invention, the surface of the blanket should be heated to a temperature above the solvation temperature of the toner image, i.e. above the temperature at which the toner particles become tacky to the final substrate. For the preferred toner of Example 1 of U. S. Patent 4,794,651, the blanket heater is preferably operative to heat the image on the intermediate transfer member to about 100-110° C.

To ensure even heating, the top of the blanket heater 92 is preferably attached to an approximately 100 micron thick aluminum foil 93. This foil also provides electromagnetic shielding of the image transfer regions of the imaging apparatus from interference produced by AC currents used to heat the blanket 92. The width of the Nichrome ribbon is chosen such that the ribbon covers a major portion, preferably over 80%, of the blanket, to ensure even heating thereof.

Disposed over foil 93 is a three part sponge assembly layer 94, including a layer 96 typically formed of Kapton, typically of thickness 100 microns, a sponge layer 98, typically of thickness 300 microns and a fabric layer 100, typically formed of NOMEX (DuPont) and being typically of thickness 350 microns. The total sponge assembly layer thickness is typically 800 microns. Nomex is basically an aromatic polyamide and chars at 420°C.

The assembly layer 94 is preferably formed by blending the following materials, which form the sponge layer 98, in the following proportions, in a two roll mill:

a.	Fluorosilicone (FSE-2080 General Electric)	78.39%
b.	Silicone (Silastic 4-2735 Dow Corning)	11.71%
c.	Blowing Agent (#9038 Rhone Poulenc)	9.00%
d.	Cross-Linker (Di Cumyl Peroxide)	0.90%

The blended material is formed into the assembly layer 94 by calendaring between the fabric layer 100 and the Kapton layer 96 as illustrated in Fig. 4.

The total thickness of assembly layer 94 is typically about 670 microns after calendaring. The assembly layer 94 is then preferably cured for 10 minutes under nitrogen at 170° C and preferably in a jig to control the total swelling thereof to a final total thickness of about 800 microns. After the curing, the assembly layer 94 preferably undergoes a post-cure at 200° C for four hours.

It is a particular feature of the present invention that the sponge assembly layer 94 allows conformity between surface 16 and intermediate transfer member 40 at the first transfer at a relatively low pressure, such as 100 - 500 gm/cm² at a temperature of about 100-110° C, with relatively low deformation, such as 30 - 200 microns, overcoming any surface unevenness of the mating surfaces.

According to a preferred embodiment of the present invention, sponge assembly layer 94 is further characterized in that it undergoes relatively high pressure, such as 2000 to 4000 gm/cm² at the second transfer with proportionately

low deformation, greater than that at first transfer, preferably about 250 microns.

It is believed that when the voltage on the rigidizing roller 30 is high enough to cause substantial compression of the image, generally at a value which also causes corona, the pressure at the first transfer surface can be increased up to about 500 gm/cm², without substantial image degradation.

Returning now to the structure of the intermediate transfer blanket 82, it is seen that over sponge assembly layer 94, there is provided a blanket 102, typically of about 1200 microns thickness.

Blanket 102 typically includes a layer 104 of relatively stiff sponge, over which is formed a layer 106 of nitrilic rubber. Blanket 102 may be produced by removing the fabric layer from the three-ply Vulcan 714 offset printing blanket commercially available from Reeves Brothers, Inc.

Over printing blanket 102 there is provided a 2-3 micron thick layer 108 of nitrocellulose loaded with carbon black to provide a conductive layer for the high voltage applied to the intermediate transfer member. This layer has an end to end resistance of about 20 - 30 kohm, but since the current drawn to the drum is only 50 - 100 microamperes, the voltage drop on the layer is less than 3 volts out of the applied voltage of 500 - 600 volts.

An outer layer 110 typically comprises a 2 - 3 micron thick layer of silicone rubber, such as Syl-Off 294, which acts as a release layer.

A blanket 114 in accordance with an alternative preferred embodiment of the invention is shown conceptually in cross section in Fig. 3C. In this embodiment the lowest level of the blanket is a Kapton layer 116, typically 100 microns thick, which is similar to layer 96 of Fig. 3B. The next layer is a sponge layer 118, functionally similar to sponge layer 98 shown in Fig. 3B and typically 300 microns thick.

Situated above layer 118 is a heater 120, with typical thickness 650 microns, whose structure and manufacture are described hereinbelow. An acrylic rubber layer 122 is formed onto the heater 120 and preferably penetrates thereinto. A conducting layer 124 and a release layer 126 complete the blanket. Additional spacer material 128, typically of Kapton, may be added below the blanket, if additional blanket thickness is required. Alternatively the Kapton layer 116 may be thicker than the indicated thickness.

As is shown in Figs. 3D and 3E, heater 120 may be formed by weaving heater wire 130 forming the woof and twisted thread 132 as the warp. In a typical application for forming a blanket with a 30 cm axial dimension (when wrapped on drum 80) and a 41 cm circumferential dimension, wire 130 is formed of a 300 micron diameter copper core with a 10 micron lacquer coating, for a total diameter of 320 microns. Thread 132 is preferably of twisted Nomex thread with a nominal diameter of 320 microns. When wire 130 and thread 132 are formed into heater 120, the overall heater thickness and the center to center spacing of the wires are each approximately 650 microns.

Two connection wires 134 for energizing the heater are extensions of the heater wires 130. A Nomex cloth extension 136 is provided beyond each end of the heater portion of the heater 120.

The unconventional structure of the blanket heater 120 of Figs. 3D and 3E enables its placement over sponge layer 118. It is noted that heater 92 of the embodiment illustrated in Fig. 3B is placed below the sponge layer 98. Since heater 92 is relatively stiff in both the circumferential and the axial directions, placement of the heater 92 above the sponge layer would substantially shield the blanket-photoconductor and blanket-final substrate image transfer interfaces from the compression properties of the sponge assembly 94.

Heater 120, on the other hand, is stiff in the axial direction, but is pliable in the circumferential direction and thus transmits the pressure at the respective interfaces to the sponge layer. Placing the heater closer to the transfer surface allows for a lower heater temperature for the same surface temperature, and allows the sponge layer to be much cooler. The pressure along lines in the axial direction is substantially constant compared to the variations in the circumferential direction; it would be perfectly constant were the transfer surfaces perfect and the mechanical tolerances equal to zero. The imperfections and tolerances cause some small minor variations in deformation and hence in pressure along the axial lines.

An alternative preferred heater 150 is shown in Figs. 3F and 3G. In this embodiment two inputs 151 and 152 are at the same end of the heater wires and the wires are threaded in a paired spaced relationship as shown in Figs. 3F and 3G. Additional input 153 is electrically connected to the other end of the heater such that the current path between inputs 151 and 153 is of substantially the same length as that of the current path between inputs 152 and 153.

The heater 150 is preferably energized with the circuit of Fig. 6, wherein the input to a transformer 157 is an AC voltage and a pair of output terminals 154 and 156 of transformer 157 are at the same voltage and at opposite phases with respect to a third terminal 155. Terminals 154, 155 and 156 are electrically insulated from the AC input.

In operation, heater 150 is incorporated in a blanket, and installed in the apparatus of Fig. 1. Terminals 154 and 156 are electrically connected to inputs 151 and 152, and additional input 153 is connected to terminal 155. Alternatively the wires can be "crossed" at each reversal of the wire direction (at the edges of the heater). One such crossing is shown in Fig. 3H.

Alternatively, wire 153 and terminal 155 may be externally electrically connected to the bias layer 124. Alternatively wire 153 and terminal 153 may be connected to a source of high voltage in order to provide a field at the transfer regions and layer 124 may be omitted. For this last alternative, a substantially higher voltage would be required to

provide the field due to the greater distance of the heater from the transfer surface.

An alternative preferred heater 160 is shown in Fig. 3I. In this embodiment the wire and thread are woven in a similar manner to that of the embodiment shown in Fig. 3D. Two connection wires 162 and 164 for energizing the heater are extensions of the heater wire and an additional wire 168 is electrically connected to the center of the length of wire used to form the heater. In operation the heater is energized by connecting wires 162 and 164 to terminals 154 and 156 respectively, and connecting wire 168 to terminal 155.

Alternatively, wire 168 and terminal 155 could be externally electrically connected to the bias layer 124.

Layer 122 preferably has the following properties:

- a) high electrical resistivity at the operating temperature;
- b) high resilience, especially at second transfer (to receiving substrate 42), under the high pressures and deformation at that transfer;
- c) suitable hardness- approximately 40 Shore A;
- d) castability and bondability to adjacent layers;
- e) high strength, especially in tension and tear; and
- f) stability under temperature and pressure, that is to say, its pressure-deformation curve remains relatively stable after repeated compression and release at the temperature of operation.

Blanket 114 is preferably manufactured using the following process, although any other suitable manufacturing method may be used:

STEP I-Forming of layer 122 onto heater 120.

100 parts by weight of HYTEMP 4051 Acrylic rubber compound manufactured by B.F. Goodrich is mixed in a two roll mill with 15 parts of very fine silica, 4 parts sodium stearate and 2 parts NPC-50 crosslinker, until the mixture is smooth. The silica is added to increase the electrical resistivity, mechanical cohesiveness and strength of the final polymer. A heater 120 is placed in a mold coated with silicone oil, and is covered with the rubber/silica mixture. The mixture is cured in the mold to a final thickness of 1500 microns at a temperature of 180°C for 15 minutes. The mold is cooled and the resulting sheet is removed. It will be appreciated that this sheet comprises heater 120 and rubber layer 122 formed into an integral unit due to the filling of the heater by the rubber/silica mixture before curing.

STEP II-Forming of the sponge layer 118.

The procedure described above for the manufacture of the sponge assembly 94 (described in conjunction with Fig. 3B) is followed for this step, with the exception that the fabric layer 100 of that procedure is replaced by the double layer 120 and 122 produced by Step I above. The spacing of the rollers and the thickness of the sizing jig are adjusted to account for the increased thickness of the new material.

In an alternative and preferred embodiment of the invention, the following procedure is followed:

100 parts by weight of HYTEMP 4051 Acrylic rubber compound manufactured by B.F. Goodrich is mixed in a two roll mill with 15 parts of very fine silica, 4 parts of sodium stearate, 2 parts of NPC-50 crosslinker and 11 to 33 parts by weight of Blowing Agent (#9038 Rhone Poulenc) until the mixture is smooth. The silica is added to increase the cohesiveness of the sponge. 1 part of the mixture is mixed with preferably 2 parts of a solvent, preferably acetone or MEK, in order to reduce its viscosity.

The blended material is calendered between the double layer 120 and 122 and the Kapton layer 116 essentially as described above and as illustrated in Fig. 4 for the manufacture of sponge layer 98.

The total thickness of the resulting multilayer sheet 118, 122, 120 and 116 after calendering will depend on the amount of blowing agent used and can be determined experimentally.

The triple layer is cured, preferably in a jig, to control the total swelling thereof, at a temperature of 180°C for 15 minutes. The mold is cooled and the resulting sheet is removed. It will be appreciated that this sheet comprises all four layers formed into an integral unit. In an alternative embodiment of the invention the Kapton layer 116 can be replaced by a Nomex cloth layer, since the acrylic rubber layers together with a Nomex cloth layer appear to give sufficient structural strength to the blanket.

STEP III-Adding the conducting (bias) layer 124.

15 parts of HYTEMP 4051, 100 parts of MEK (methylmetacrilate), 6 parts of carbon black (Printex XE-2 manufactured by Degussa) and 2 parts of NPC-50 cross-linker are mixed in a cooled ball attritor for 12 hours. This material is wire coated onto the surface of layer 122 and cured at 150°C for 15 minutes to form an approximately 2 micron thick

conducting layer with a resistance of between 10-100 kohm/square, preferably 30-50 kohm/square, bonded to layer 122.

STEP IV-Post Curing

5 Post curing of the HYTEMP 4051 is not part of the process as recommended by the manufacturer. however it has been found that the stability of the material under compression cycling at operating temperature was improved by the addition of a 180° C, 12 hour post curing step.

10 STEP V-Adding the silicone release layer 126.

100 parts of Syl-off 294 is diluted 1:1 with Isopar L. 15 parts of Syl-off 297 ancorning agent and 5 parts of Dow Corning 176 cross-linker are added to the mixture. This mixture is wire coated on to the surface of conducting layer 124 and air cured at 110°C for 10 minutes to provide a 5-6 micron thick layer.

15 Fig. 5 is a graph which illustrates the approximate desired pressure/deformation characteristics of the intermediate transfer member structures shown in Fig. 3B-3I, under ordinary use conditions, in intermediate transfer apparatus constructed and operative according to a preferred embodiment of the present invention.

20 The invention is illustrated herein with examples employing a single developer station. The invention is especially useful in imaging systems with a multiplicity of development stations preferably with different color liquid developers, or with a single station in which the liquid developer is changed between colors. For either of these systems each individual color image may be transferred to the final substrate from the ITM individually, or the colored images may be transferred sequentially to the ITM and then transferred to the substrate together. Color imaging equipment is described in U. S. Patents 4,788,572; 4,690,539 and 3,900,003.

25 It will be appreciated by persons skilled in the art that the present invention is not limited by what has been particularly shown and described hereinabove. Rather the scope of the present invention is defined only by the claims which follow:

30 **Claims**

1. Imaging apparatus comprising:

- an image bearing surface (16);
- means for forming a toner image on the image bearing surface (18, 20, 22, 24);
- 35 an intermediate transfer member (40, 70, 114) operative for transfer of the toner image from the image bearing surface to a substrate (42);
- means for providing first transfer engagement between the intermediate transfer member and the image bearing surface for transfer of the toner image from the image bearing surface to the intermediate transfer member at a first pressure, producing deformation of the intermediate transfer member to a first deformation degree;
- 40 means for providing second transfer engagement between the intermediate transfer member and the substrate for transfer of the toner image from the intermediate transfer member to the substrate at a second pressure, producing deformation of the intermediate transfer member to a second deformation degree,

characterized in that:

- 45 the toner image is a liquid toner image; and
- the ratio of the second pressure to the first pressure is substantially greater than the ratio of the second deformation degree to the first deformation degree.

50 2. Apparatus according to claim 1 wherein the intermediate transfer member comprises a conductive layer (108, 124) operative to apply an electric field to the image to enhance transfer of the liquid toner image from the image bearing surface to the intermediate transfer member.

55 3. Apparatus according to claim 1 or claim 2 wherein the intermediate transfer member comprises a blanket heater (92, 120) operative to heat the liquid toner image thereon prior to the second transfer engagement.

4. Apparatus according to claim 3 wherein the first and second pressures are substantially constant along lines in the axial direction upon the first and second transfer engagements on the intermediate transfer member, and

wherein the heater (120) is formed of thin wires (130) along the lines.

5. Apparatus according any claim 1 or claim 2, wherein the intermediate transfer member comprises:

- an outward facing transfer surface (126, 110);
- a compressible layer (98, 104, 98, 118);
- a backing layer (116, 90, 128); and
- a heating layer (92, 120) disposed intermediate the backing layer and the transfer surface.

6. Apparatus according to claim 5 wherein the intermediate transfer member comprises a second compressible layer (98, 104).

7. Apparatus according to claim 6 wherein the heating layer is disposed intermediate the compressible layer and the second compressible layer.

8. Apparatus according to claim 1 or claim 2 wherein the intermediate transfer member comprises a resilient layer (106, 122) and a compressible layer (98, 118, 104).

9. Apparatus according to claim 8 and also comprising an area heater (120) disposed between the resilient and compressible layers.

10. Apparatus according to claim 5 and wherein the heating layer is disposed intermediate the transfer surface and the compressible layer.

11. Apparatus according to any of the preceding claims wherein the intermediate transfer member (40, 72) has an image transfer surface (110, 126) and is operative for transfer of a toner image from the image bearing surface to the image transfer surface for subsequent transfer therefrom to a second surface (42),

- wherein the intermediate transfer member comprises:
- a transfer surface for operative engagement with the image bearing surface;
- a resilient layer (122);
- a sponge layer which is softer than the resilient layer (118); and
- an area heater (120) disposed between the relatively compliant sponge layer and the resilient layer.

12. Apparatus according to claim 11 wherein the intermediate transfer member comprises a conductive layer (124) operative to apply on electric field to the toner image to enhance transfer of the toner image from the image bearing surface to the intermediate transfer member.

13. Apparatus according to claim 11 or claim 12 and further comprising:

- means for providing first transfer engagement between the intermediate transfer member and the image bearing surface for transfer of an image from the image bearing surface to the intermediate transfer member at a first pressure; and
- means for providing second transfer engagement between the intermediate transfer member and the substrate for transfer of the image from the intermediate transfer member to the second surface at a second pressure, wherein the first and second pressure is substantially constant along axial lines on the intermediate transfer member upon the first and second transfer engagements, and wherein the heating layer is formed of thin wires (130) disposed along the lines.

14. Apparatus according to claim 13, wherein the heating layer is energized by alternating current and the thin wires are arranged in adjoining pairs, each pair comprising first and second wires, the voltage on the first wire of a pair being substantially equal and of opposite sign to that of the second wire of the pair relative to a reference voltage.

15. Apparatus according to claim 14, wherein the reference voltage is ground.

16. Apparatus according to any of claims 11-15 wherein the compressible layer has a thickness of about 300 micrometers.

17. Apparatus according to any of claims 11-16 wherein the heating layer is disposed intermediate the compressible layer and the transfer surface.
18. Apparatus according to any of the preceding claims wherein the intermediate transfer member comprises a rigid core (80) and an intermediate transfer blanket (82) wrapped around and attached to the core.

Patentansprüche

1. Abbildungsvorrichtung, umfassend:
- eine bildtragende Fläche (16);
 - Einrichtungen zum Bilden eines Tonerbildes auf der bildtragenden Fläche (18, 20, 22, 24);
 - ein Zwischenübertragungselement (40, 70, 114), das zur Übertragung des Tonerbildes von der bildtragenden Fläche auf ein Substrat (42) wirksam ist;
 - eine Einrichtung zum Bereitstellen eines ersten Übertragungseingriffs zwischen dem Zwischenübertragungselement und der bildtragenden Fläche zur Übertragung des Tonerbildes von der bildtragenden Fläche zum Zwischenübertragungselement bei einem ersten Druck, der eine Verformung des Zwischenübertragungselementes bis zu einem ersten Verformungsgrad hervorruft;
 - eine Einrichtung zum Bereitstellen eines zweiten Übertragungseingriffs zwischen dem Zwischenübertragungselement und dem Substrat zur Übertragung des Tonerbildes vom Zwischenübertragungselement auf das Substrat bei einem zweiten Druck, der eine Verformung des Zwischenübertragungselementes bis zu einem zweiten Verformungsgrad hervorruft,
- dadurch gekennzeichnet, daß:
- das Tonerbild ein Flüssigtonerbild ist; und
 - das Verhältnis des zweiten Druckes zum ersten Druck wesentlich größer ist als das Verhältnis des zweiten Verformungsgrades zum ersten Verformungsgrad.
2. Vorrichtung nach Anspruch 1, bei der das Zwischenübertragungselement eine leitfähige Schicht (108, 124) umfaßt, die wirksam ist, um zur Verbesserung der Übertragung des Flüssigtonerbildes von der bildtragenden Fläche zum Zwischenübertragungselement ein elektrisches Feld an das Bild anzulegen.
3. Vorrichtung nach Anspruch 1 oder Anspruch 2, bei der das zwischenübertragungselement eine Deckeheizeinrichtung (92, 120) umfaßt, die wirksam ist, um das Flüssigtonerbild auf demselben vor dem zweiten Übertragungseingriff zu erwärmen.
4. Vorrichtung nach Anspruch 3, bei welcher der erste und zweite Druck bei dem ersten und zweiten Übertragungseingriff auf dem Zwischenübertragungselement längs Linien in der axialen Richtung wesentlich konstant sind und bei welcher die Heizeinrichtung (120) längs der Linien aus dünnen Drähten (130) gebildet ist.
5. Vorrichtung nach einem beliebigen von Anspruch 1 oder Anspruch 2, bei der das Zwischenübertragungselement umfaßt:
- eine der Außenseite zugewandte Übertragungsfläche (126, 110);
 - eine zusammendrückbare Schicht (98, 104, 98, 118);
 - eine Stützschiicht (116, 90, 128); und
 - eine Heizschicht (92, 120), die zwischen der Stützschiicht und der Übertragungsfläche liegend angeordnet ist.
6. Vorrichtung nach Anspruch 5, bei der das Zwischenübertragungselement eine zweite zusammendrückbare Schicht (98, 104) umfaßt.
7. Vorrichtung nach Anspruch 6, bei der die Heizschicht zwischen der zusammendrückbaren Schicht und der zweiten zusammendrückbaren Schicht liegend angeordnet ist.
8. Vorrichtung nach Anspruch 1 oder Anspruch 2, bei der das Zwischenübertragungselement eine elastische Schicht (106, 122) und eine zusammendrückbare Schicht (98, 118, 104) umfaßt.

9. Vorrichtung nach Anspruch 8 und auch umfassend eine Flächenheizeinrichtung (120), die zwischen der elastischen und der zusammendrückbaren Schicht liegend angeordnet ist.
- 5 10. Vorrichtung nach Anspruch 5 und bei der die Heizschicht zwischen der Übertragungsfläche und der zusammendrückbaren Schicht liegend angeordnet ist.
- 10 11. Vorrichtung nach einem beliebigen der vorangehenden Ansprüche, bei der das Zwischenübertragungselement (40, 72) eine Bildübertragungsfläche (110, 126) aufweist und zur Übertragung eines Tonerbildes von der bildtragenden Fläche auf die Bildübertragungsfläche zum Zweck einer anschließenden Übertragung von derselben auf eine zweite Fläche (42) wirksam ist,
bei der das Zwischenübertragungselement umfaßt:
- 15 eine Übertragungsfläche zum Arbeitseingriff mit der bildtragenden Fläche;
eine elastische Schicht (122);
eine Schaumstoffschicht (118), die weicher ist als die elastische Schicht; und
eine Flächenheizeinrichtung (120), die zwischen der relativ nachgiebigen Schaumstoffschicht und der elastischen Schicht angeordnet ist.
- 20 12. Vorrichtung nach Anspruch 11, bei der das Zwischenübertragungselement umfaßt: eine leitfähige Schicht (124), die wirksam ist, um zur Verbesserung der Übertragung des Tonerbildes von der bildtragenden Fläche zum Zwischenübertragungselement ein elektrisches Feld an das Tonerbild anzulegen.
- 25 13. Vorrichtung nach Anspruch 11 oder Anspruch 12 und weiter umfassend:
- eine Einrichtung zum Bereitstellen eines ersten Übertragungseingriffs zwischen dem Zwischenübertragungselement und der bildtragenden Fläche zur Übertragung eines Bildes von der bildtragenden Fläche zum Zwischenübertragungselement bei einem ersten Druck; und
eine Einrichtung zum Bereitstellen eines zweiten Übertragungseingriffs zwischen dem Zwischenübertragungselement und dem Substrat zur Übertragung des Bildes vom Zwischenübertragungselement auf die zweite
30 Fläche bei einem zweiten Druck,
bei welcher der erste und zweite Druck bei dem ersten und zweiten Übertragungseingriff längs axialer Linien auf dem Zwischenübertragungselement wesentlich konstant sind und bei welcher die Heizschicht aus dünnen Drähten (130) gebildet ist, die längs der Linien angeordnet sind.
- 35 14. Vorrichtung nach Anspruch 13, bei der in die Heizschicht Wechselstrom eingespeist wird und die dünnen Drähte in nebeneinander liegenden Paaren angeordnet sind, wobei jedes Paar einen ersten und zweiten Draht umfaßt, die Spannung an dem ersten Draht eines Paares im wesentlichen gleich und von entgegengesetztem Vorzeichen bezüglich derjenigen des zweiten Drahtes des Paares bezogen auf eine Bezugsspannung ist.
- 40 15. Vorrichtung nach Anspruch 14, bei der die Bezugsspannung Masse ist.
16. Vorrichtung nach einem beliebigen der Ansprüche 11-15, bei der die zusammendrückbare Schicht eine Dicke von etwa 300 Mikrometern aufweist.
- 45 17. Vorrichtung nach einem beliebigen der Ansprüche 11-16, bei der die Heizschicht zwischen der zusammendrückbaren Schicht und der Übertragungsfläche liegend angeordnet ist.
18. Vorrichtung nach einem beliebigen der vorangehenden Ansprüche, bei der das Zwischenübertragungselement einen starren Kern (80) und eine zwischenübertragungsdecke (82), die um den Kern gewickelt ist und an ihm befestigt ist, umfaßt.
- 50

Revendications

- 55 1. Appareil de formation d'image comprenant :
- une surface (16) de support d'image,
 - des moyens (18, 20, 22, 24) pour former une image de toner sur la surface de support d'image,

EP 0 584 893 B1

- un organe (40, 70, 114) de transfert intermédiaire servant à transférer l'image de toner de la surface de support d'image à un substrat (42),
- des moyens pour réaliser un premier contact de transfert entre l'organe de transfert intermédiaire et la surface de support d'image en vue du transfert de l'image de toner de la surface de support d'image à l'organe de transfert intermédiaire à une première valeur de la pression, en produisant une déformation de l'organe de transfert intermédiaire jusqu'à un premier degré de déformation,
- des moyens pour réaliser un second contact de transfert entre l'organe de transfert intermédiaire et le substrat en vue du transfert de l'image de toner de l'organe de transfert intermédiaire au substrat à une seconde valeur de la pression, en produisant une déformation de l'organe de transfert intermédiaire jusqu'à un second degré de déformation,

caractérisé en ce que :

- l'image de toner est une image de toner liquide, et
- le rapport entre la seconde valeur de la pression et la première valeur de la pression est sensiblement plus grand que le rapport entre le second degré de déformation et le premier degré de déformation.

2. Appareil selon la revendication 1, dans lequel l'organe de transfert intermédiaire comprend une couche conductrice (108, 124) servant à appliquer un champ électrique à l'image pour améliorer le transfert de l'image de toner liquide de la surface de support d'image à l'organe de transfert intermédiaire.

3. Appareil selon la revendication 1 ou la revendication 2, dans lequel l'organe de transfert intermédiaire comprend un dispositif (92, 120) de chauffage de blanchet servant à chauffer l'image de toner liquide qu'il porte avant le second contact de transfert.

4. Appareil selon la revendication 3, dans lequel les première et seconde valeurs de pression sont sensiblement constantes le long de lignes dirigées axialement sur l'organe de transfert intermédiaire lors des premier et second contacts de transfert, et dans lequel le dispositif chauffant (120) est formé de minces fils (130) situés le long de ces lignes.

5. Appareil selon la revendication 1 ou la revendication 2, dans lequel l'organe de transfert intermédiaire comprend :

- une surface de transfert (126, 110) tournée vers l'extérieur,
- une couche compressible (98, 104, 98, 118),
- une couche d'appui (116, 90, 128), et
- une couche chauffante (92, 120) placée entre la couche d'appui et la surface de transfert.

6. Appareil selon la revendication 5, dans lequel l'organe de transfert intermédiaire comprend une seconde couche compressible (98, 104).

7. Appareil selon la revendication 6, dans lequel la couche chauffante est placée entre la couche compressible et la seconde couche compressible.

8. Appareil selon la revendication 1 ou la revendication 2, dans lequel l'organe de transfert intermédiaire comprend une couche élastique (106, 122) et une couche compressible (98, 118, 104).

9. Appareil selon la revendication 8, comprenant en outre un dispositif (120) de chauffage de surface placé entre les couches élastique et compressible.

10. Appareil selon la revendication 5, dans lequel la couche chauffante est placée entre la surface de transfert et la couche compressible.

11. Appareil selon l'une quelconque des précédentes revendications, dans lequel l'organe de transfert intermédiaire (40, 72) comprend une surface (110, 126) de transfert d'image et sert à transférer une image de toner de la surface de support d'image à la surface de transfert d'image en vue d'un transfert ultérieur de celle-ci à une deuxième surface (42), dans lequel l'organe de transfert intermédiaire comprend :

- une surface de transfert destinée à venir en contact opérationnel avec la surface de support d'image,
- une couche élastique (122),
- une couche spongieuse qui est plus molle que la couche élastique (118), et
- un dispositif (120) de chauffage de surface placé entre la couche spongieuse relativement souple et la couche élastique.

5

12. Appareil selon la revendication 11, dans lequel l'organe de transfert intermédiaire comprend une couche conductrice (124) servant à appliquer un champ électrique à l'image de toner pour améliorer le transfert de l'image de toner de la surface de support d'image à l'organe de transfert intermédiaire.

10

13. Appareil selon la revendication 11 ou la revendication 12, comprenant en outre :

- des moyens pour réaliser un premier contact de transfert entre l'organe de transfert intermédiaire et la surface de support d'image en vue du transfert d'une image de la surface de support d'image à l'organe de transfert intermédiaire à une première valeur de la pression, et
- des moyens pour réaliser un second contact de transfert entre l'organe de transfert intermédiaire et le substrat en vue du transfert de l'image de l'organe de transfert intermédiaire à la seconde surface à une seconde valeur de la pression, dans lequel les première et seconde valeurs de la pression sont sensiblement constantes le long de lignes axiales sur l'organe de transfert intermédiaire lors des premier et second contacts de transfert, et dans lequel la couche chauffante est formée de minces fils (130) disposés suivant ces lignes.

15

20

14. Appareil selon la revendication 13, dans lequel la couche chauffante est alimentée en énergie par un courant alternatif et les minces fils sont disposés en paires contiguës, chaque paire comprenant des premier et second fils métalliques, la tension appliquée sur le premier fil d'une paire étant sensiblement égale mais de signe opposé à celle appliquée sur le deuxième fil de la paire par rapport à une tension de référence.

25

15. Appareil selon la revendication 14, dans lequel la tension de référence est la masse.

16. Appareil selon l'une quelconque des revendications 11 à 15, dans lequel la couche compressible a une épaisseur d'environ 300 micromètres.

30

17. Appareil selon l'une quelconque des revendications 11 à 16, dans lequel la couche chauffante est placée entre la couche compressible et la surface de transfert.

35

18. Appareil selon l'une quelconque des précédentes revendications, dans lequel l'organe de transfert intermédiaire comprend un noyau rigide (80) et un blanchet (82) de transfert intermédiaire enroulé autour du noyau auquel il est fixé.

40

45

50

55

FIG. 1

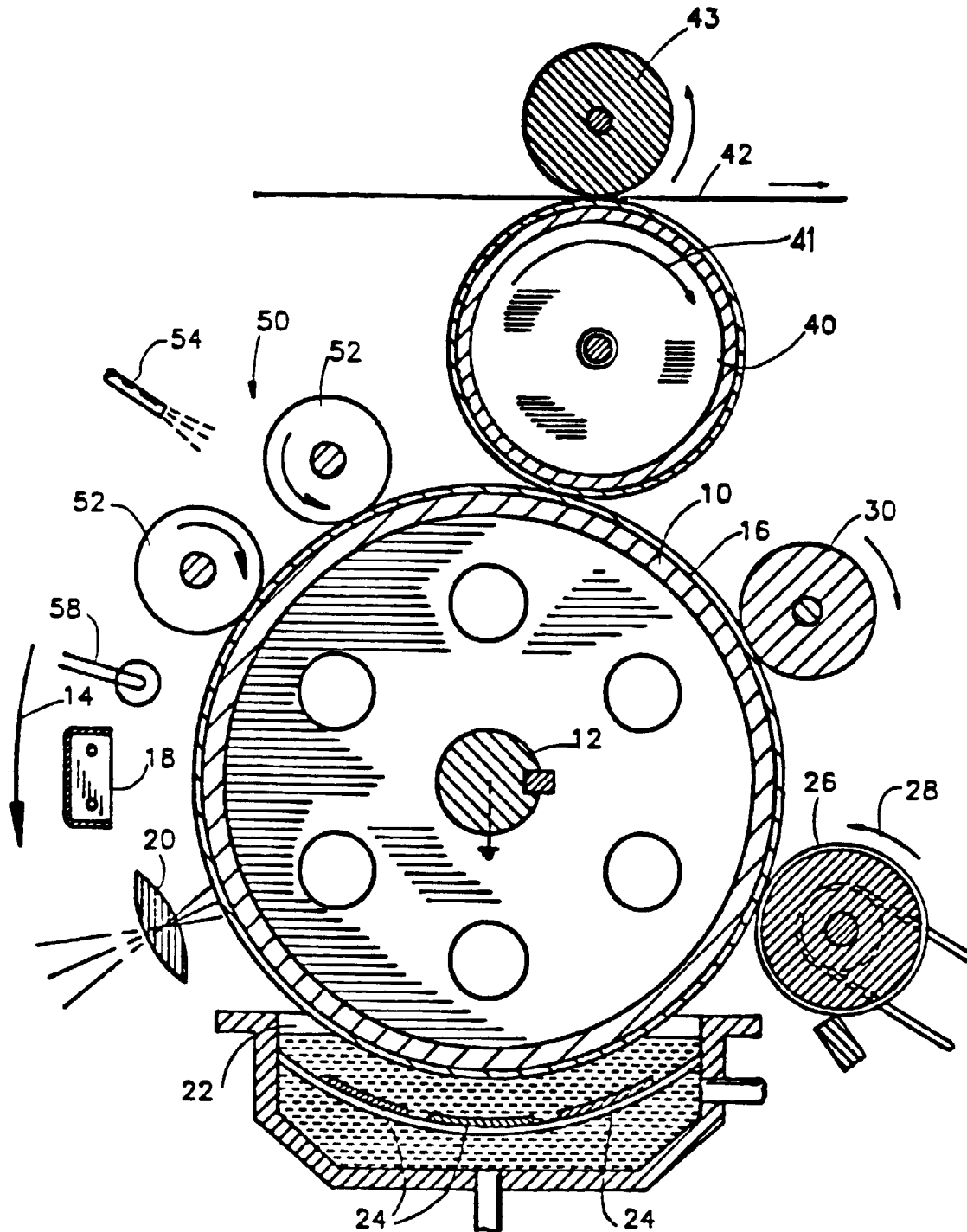
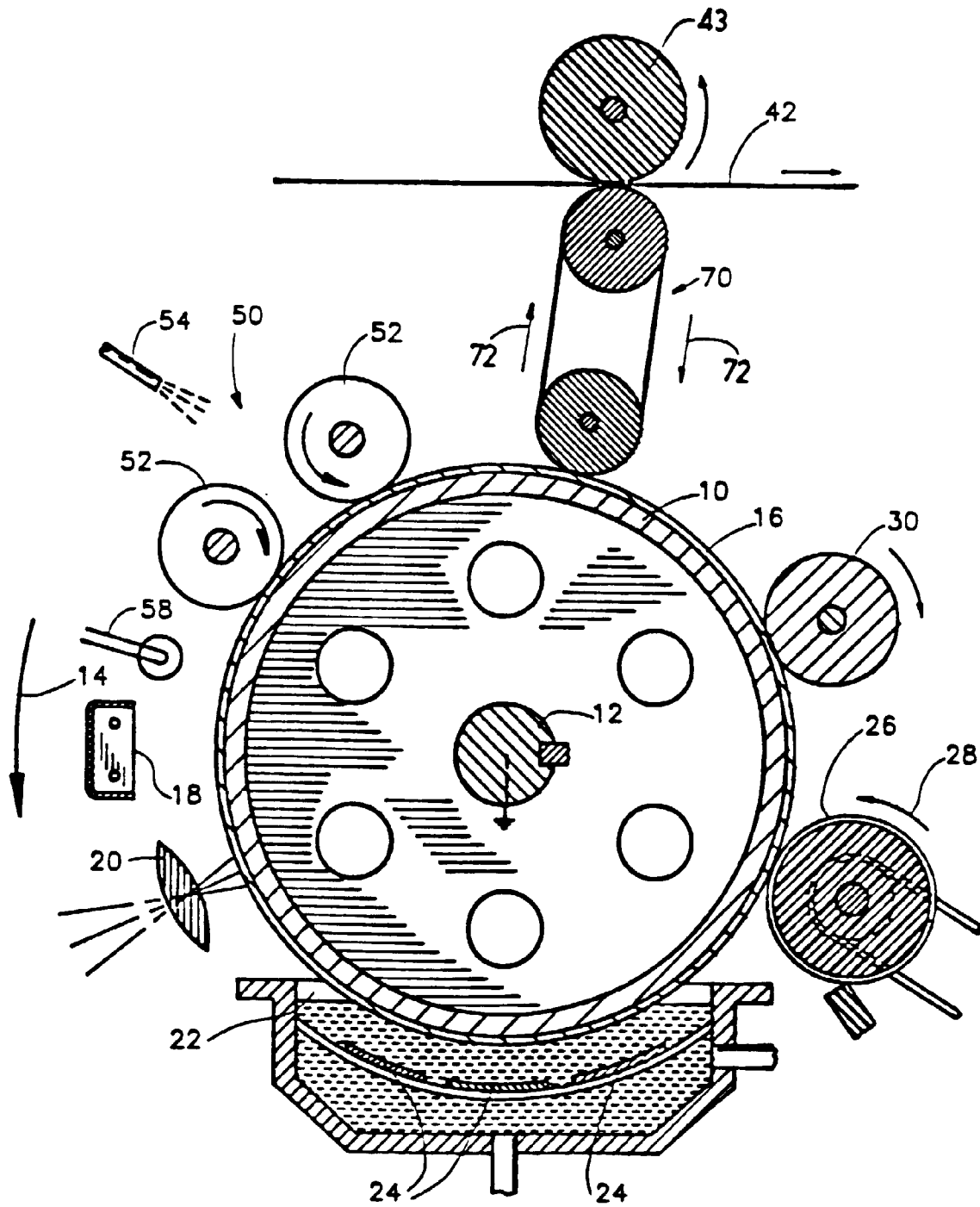

FIG. 2



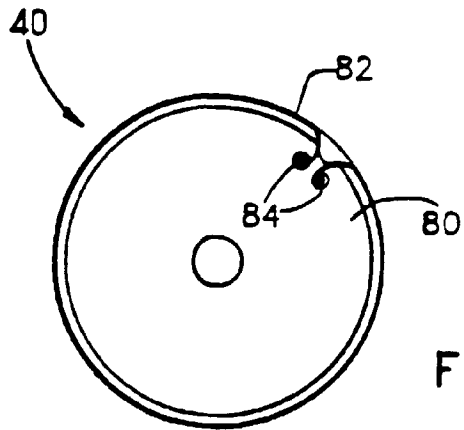

FIG. 3A

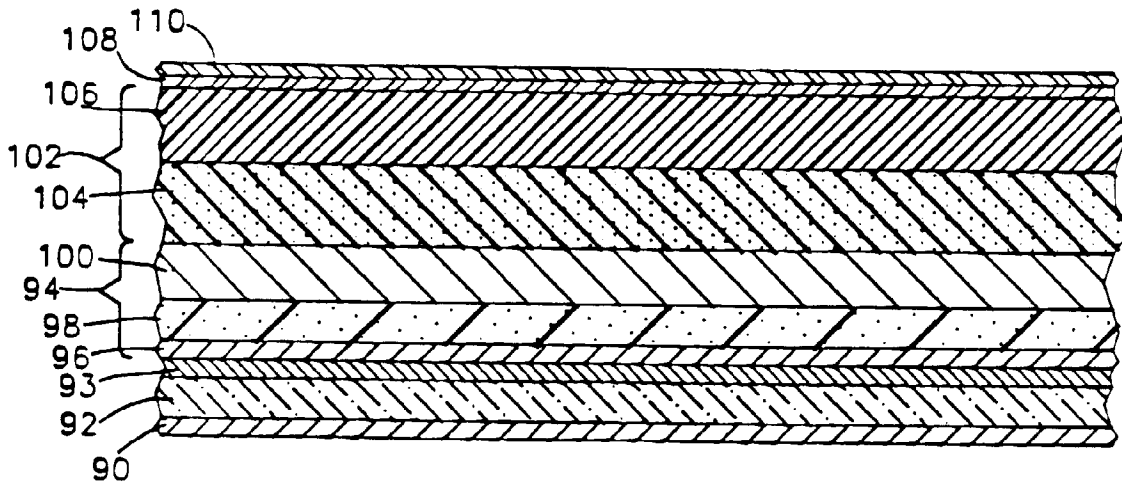

FIG. 3B

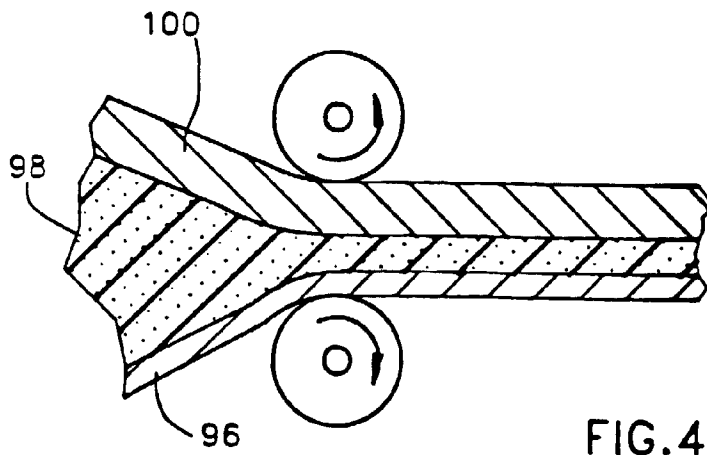

FIG. 4

FIG.3C

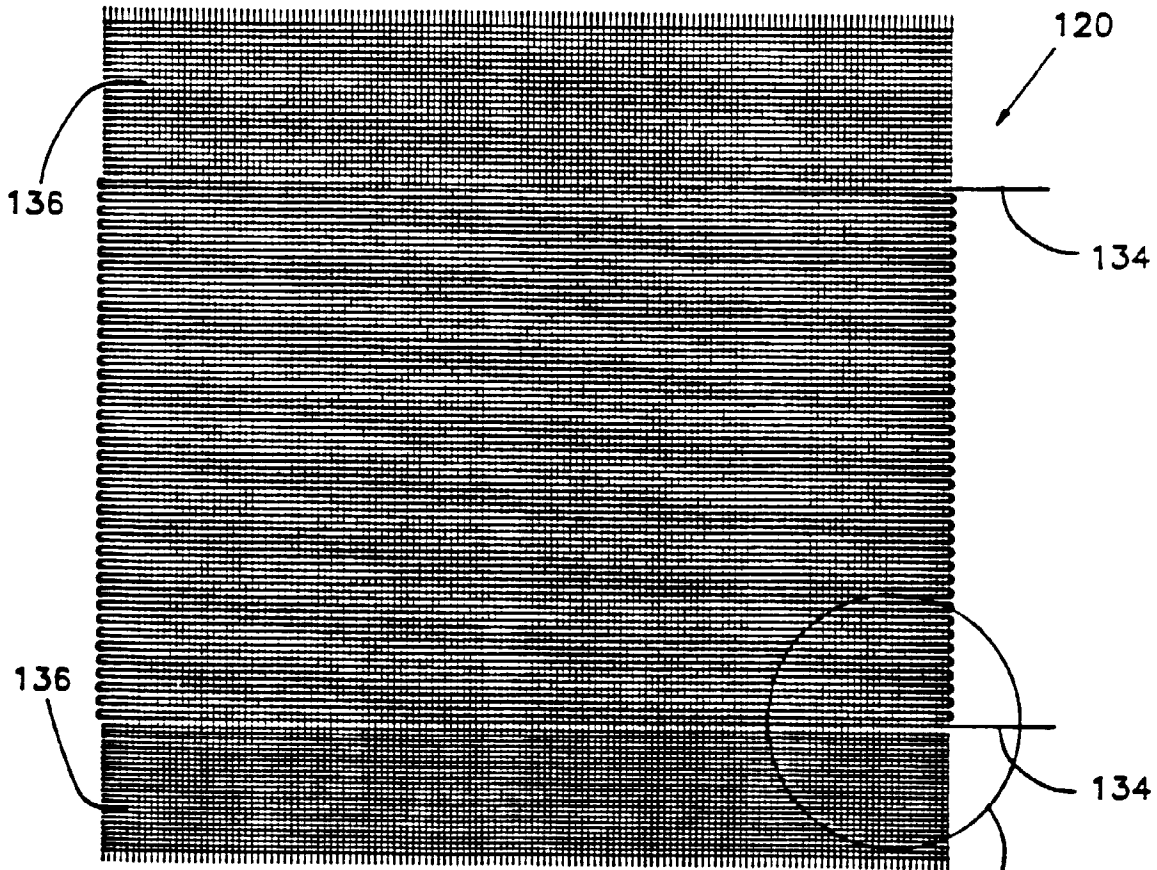
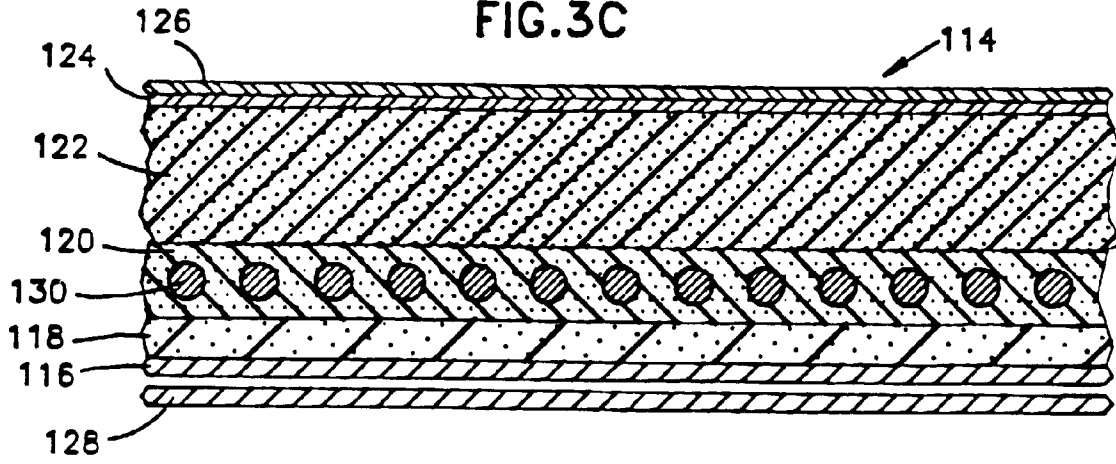
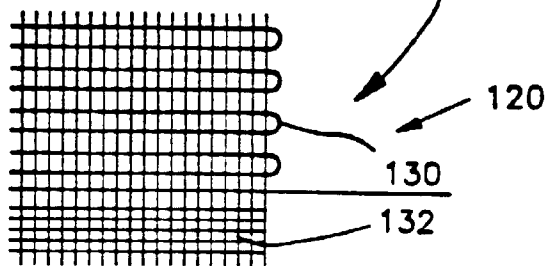
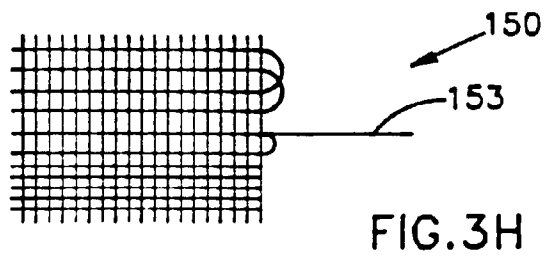
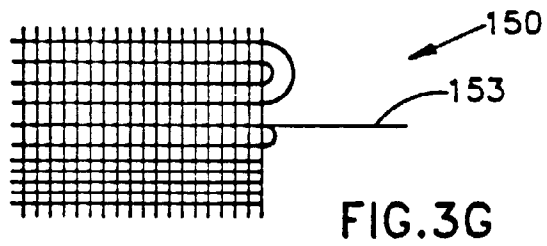
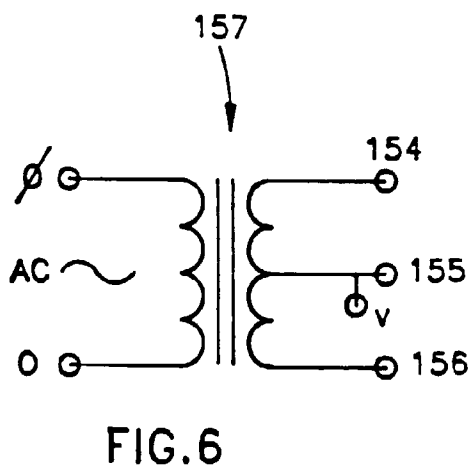
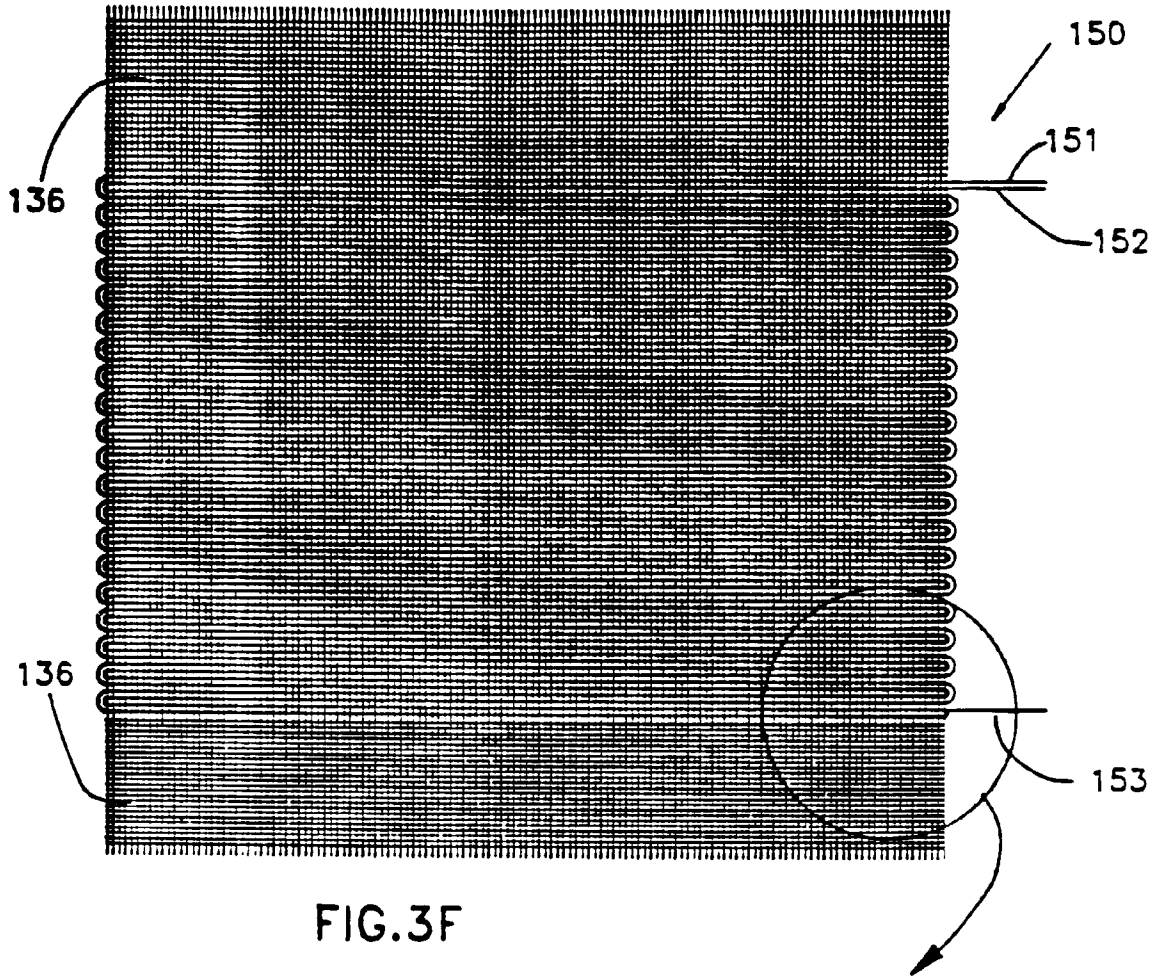

FIG.3D

FIG.3E





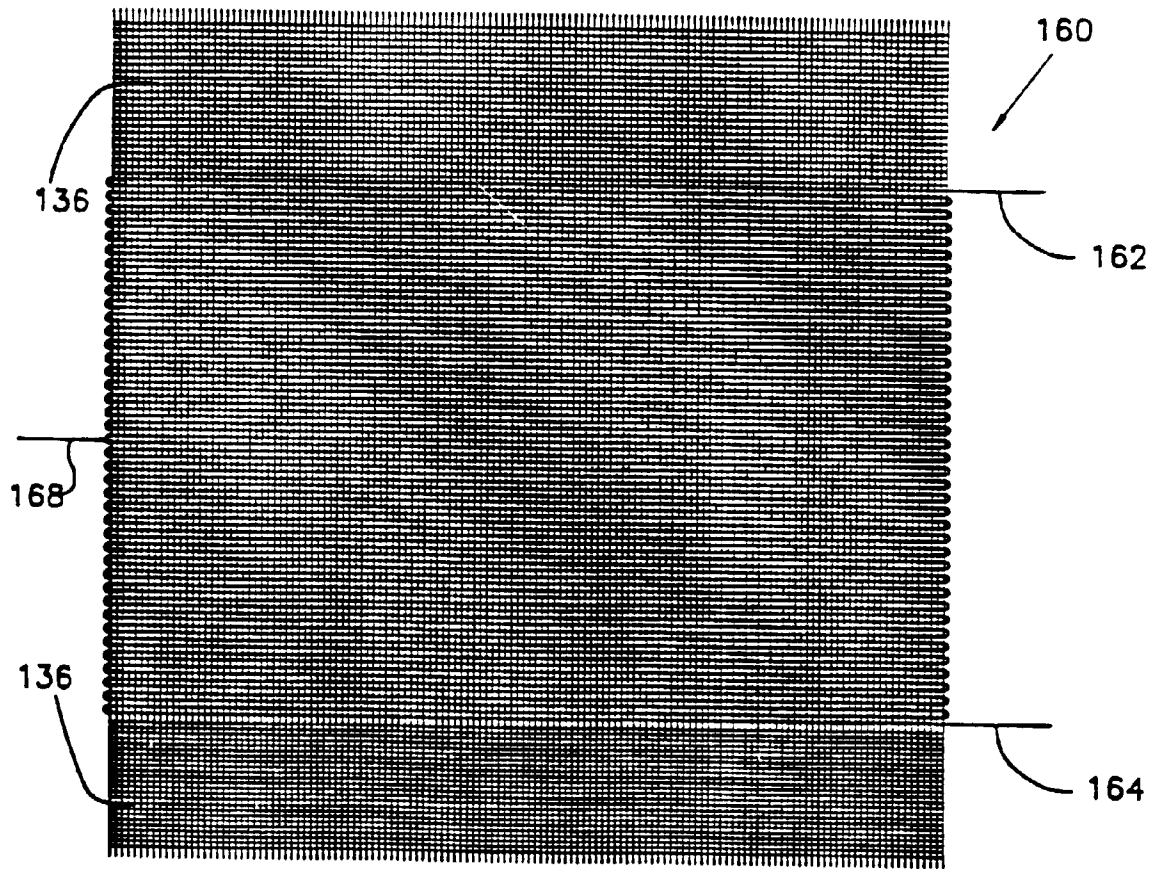

FIG.3 I

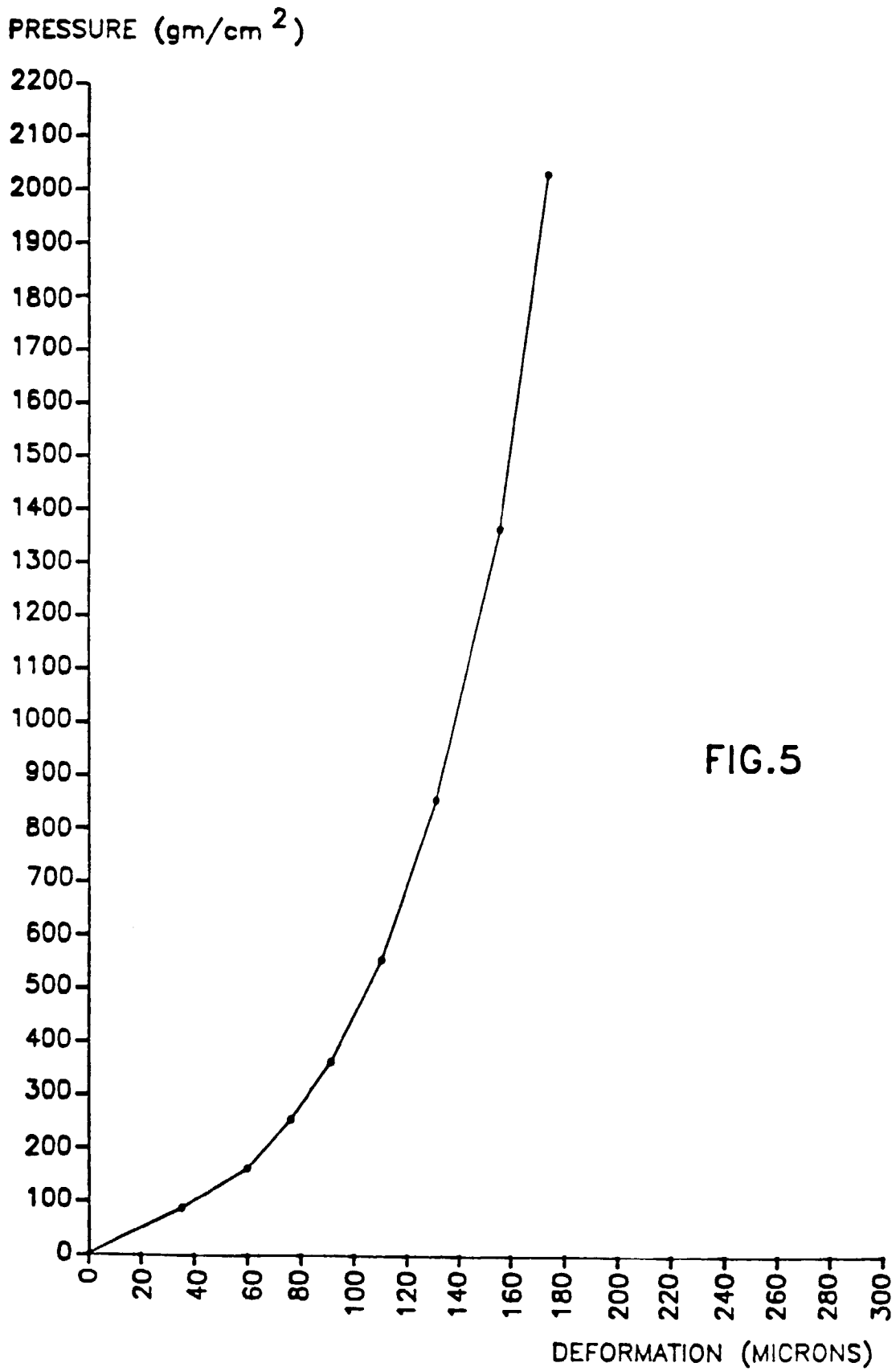

FIG.5