



(51) International Patent Classification:
A61M 5/315 (2006.01)

(21) International Application Number:
PCT/EP2010/056977

(22) International Filing Date:
20 May 2010 (20.05.2010)

(25) Filing Language: English

(26) Publication Language: English

(30) Priority Data:
09006821.4 20 May 2009 (20.05.2009) EP

(71) Applicant (for all designated States except US):
SANOFI-AVENTIS DEUTSCHLAND GMBH
[—/DE]; Brünningstraße 50, 65929 Frankfurt (DE).

(72) Inventors; and

(75) Inventors/Applicants (for US only): **POMMEREAU, Christian** [DE/DE]; c/o Sanofi-Aventis Deutschland GmbH, 65926 Frankfurt am Main (DE). **LIEWALD, Anke** [DE/DE]; c/o Sanofi-Aventis Deutschland GmbH, 65926 Frankfurt am Main (DE).

(81) Designated States (unless otherwise indicated, for every kind of national protection available): AE, AG, AL, AM, AO, AT, AU, AZ, BA, BB, BG, BH, BR, BW, BY, BZ, CA, CH, CL, CN, CO, CR, CU, CZ, DE, DK, DM, DO, DZ, EC, EE, EG, ES, FI, GB, GD, GE, GH, GM, GT, HN, HR, HU, ID, IL, IN, IS, JP, KE, KG, KM, KN, KP, KR, KZ, LA, LC, LK, LR, LS, LT, LU, LY, MA, MD, ME, MG, MK, MN, MW, MX, MY, MZ, NA, NG, NI, NO, NZ, OM, PE, PG, PH, PL, PT, RO, RS, RU, SC, SD, SE, SG, SK, SL, SM, ST, SV, SY, TH, TJ, TM, TN, TR, TT, TZ, UA, UG, US, UZ, VC, VN, ZA, ZM, ZW.

(84) Designated States (unless otherwise indicated, for every kind of regional protection available): ARIPO (BW, GH, GM, KE, LR, LS, MW, MZ, NA, SD, SL, SZ, TZ, UG, ZM, ZW), Eurasian (AM, AZ, BY, KG, KZ, MD, RU, TJ, TM), European (AL, AT, BE, BG, CH, CY, CZ, DE, DK, EE, ES, FI, FR, GB, GR, HR, HU, IE, IS, IT, LT, LU, LV, MC, MK, MT, NL, NO, PL, PT, RO, SE, SI, SK, SM, TR), OAPI (BF, BJ, CF, CG, CI, CM, GA, GN, GQ, GW, ML, MR, NE, SN, TD, TG).

Published:

— with international search report (Art. 21(3))

(54) Title: A BUNG FOR DRUG CONTAINING CARTRIDGES IN DRUG DELIVERY DEVICES

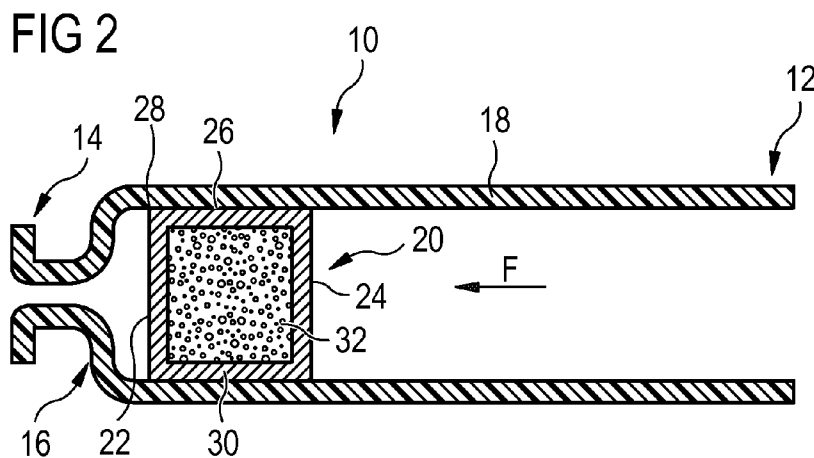

(57) Abstract: The present invention relates to a bung (20) for drug containing cartridges (10) for use in drug delivery devices wherein the bung (20) has a distal end face (22), a proximal end face (24) and a lateral area (26), wherein the bung (20) comprises at least two different materials, a first material (30) covering the whole lateral area (26) of the bung (20) and a second material (32) which is at least partly arranged inside the bung (20), wherein the first material (30) has a larger compressibility than the second material (32) and wherein the whole lateral area (26) has a flat surface. Furthermore, it relates to a cartridge (10) and to a drug delivery device comprising a bung (20) as claimed.

WO 2010/133675 A1

Description

A bung for drug containing cartridges in drug delivery devices

- 5 The present invention relates to a bung for drug-containing cartridges for use in drug delivery devices.

Drug delivery devices are generally known for the administration of a drug, for example insulin, but also for other medicinal products for self-administration by a patient.

10

Because of the daily necessity to use these drug delivery devices, there are ambitions to make the use of these drug delivery devices more comfortable and safer for the user. An endeavor in this field is to avoid dose inaccuracy while dispensing the last dose from the cartridge. Some examples to solve this problem are known from WO
15 2005/099793 A1 and from US 2007/0219507 A1.

It is an object of the present invention to provide a bung for drug-containing cartridges for use in drug delivery devices which helps to avoid dose inaccuracy.

- 20 According to a first aspect of the disclosure, a bung for drug-containing cartridges for use in drug delivery devices is provided wherein the bung has a distal end face, a proximal end face and a lateral area, wherein the bung comprises at least two different materials, a first material covering the whole lateral area of the bung and a second material which is at least partly arranged inside the bung, wherein the first material has
25 a larger compressibility than the second material and wherein the whole lateral area has a flat surface.

- The bung is intended for sealing the proximal end of a cartridge by forming a liquid-proof closure between the lateral area of the bung and a main body portion of the
30 cartridge. For this purpose the bung comprises two materials, a first material which is softer and a second material which is harder than the first material.

The first material is covering the whole lateral area of the bung and due to the relatively high compressibility of the first material the bung is able to adapt its shape to the shape of the main body portion of the cartridge. Furthermore it is preferred that the first material is chosen such that the bung is enabled to be easily slid by a piston in axial direction along the main body portion. The bung is driven forward, by mechanical contact between the piston and the bung.

The second material is at least partly arranged inside the bung and provides a rigid core to resist or at least to limit axial compression of the bung while a piston is pressed onto the bung and is applying a force in distal direction.

In a preferred embodiment the second material comprises metal.

The second material which is at least partly arranged inside the bung can comprise metal. This metal can be pure metal or an alloy.

An alloy is herein after understood as a mixture of two or more elements in which the major component is a metal. Metals can be shaped by processes such as casting, extrusion, sintering and machining.

20

To be more specific with casting, molten metal is poured into a shaped mould. With extrusion, a hot and malleable metal is forced under pressure through a die, which shapes it before it cools. With sintering, a powdered metal is compressed into a die at high temperature. With machining, lathes, milling machines, and drills cut the cold metal to shape.

25

According to another preferred embodiment the second material comprises ceramic.

Ceramic forming techniques are for example injection moulding, dry pressing, and other variations.

30

With injection moulding, liquid ceramic is filled into a mould. With dry pressing, ceramic powder is pressed in mechanical or hydraulic powder compacting presses.

In one embodiment the second material comprises a polymer matrix.

5 In case that both the first and the second material comprise a polymer a polymer with a smaller compressibility than the first material is used as second material. The material used as second material has a longer chain length than the first material in order to decrease the compressibility. By varying the chain length of the polymer materials the strength and toughness of the materials can be modulated. Crosslinking, like vulcanization also increases strength and toughness of the material.

10

By increasing the chain length, the chain interactions also increase and therefore the Van-der-Waals-attractions and entanglements increase. The chains are held more strongly in position and resist deformations. The result is that the matrix breaks up at higher stresses and higher temperatures. Besides the chain length having an influence in the properties of a polymer there is another influence given by the fact that a polymer is branched or unbranched. Basically, the more branched a polymer is, the tighter is the polymer.

15

In another preferred embodiment, the first material comprises rubber.

20

Materials that may be considered for coating the surface are, for example, silicone rubber and acrylic rubber. All elastomers are conceivable for being used as first material.

25

In another preferred embodiment the first material of the bung arranged at the lateral area enables the bung, together with the shape of the bung, to seal a proximal end of a drug-containing cartridge.

30

The surface material should almost completely resist to being dissolved in the drug contained in the cartridge and particularly, very few monomers should be dissolved if the surface material is a polymer. There should also be only low abrasion with the cartridge while the bung is axially displaced for dispensing the drug.

In a preferred embodiment the first material of the bung covers the distal end face of the bung.

- 5 By covering the distal end face and the lateral area of the bung, it is possible to have a consistent surface structure in the lateral area and at the distal end face of the bung which is easy to manufacture.

In a particularly preferred embodiment the distal end face of the bung has a flat surface.

10

This flat surface is advantageous to increase the dose accuracy while dispensing the last dose from the medicament cartridge wherein dose means a certain volume of a liquid medicinal product. For dispensing the last dose of the drug, the bung is moved forward by the mechanical contact with a piston in a drug delivery device.

15

Near the distal end of the cartridge, an edge of the distal end face of the bung abuts a shoulder portion of the cartridge and the bung comes to a stop. While abutting this shoulder portion, the first material, in particular the first material at the edge of the distal end face, is compressed in axial direction.

20

By having a flat surface and a constant and thin layer thickness at the distal end face of the bung, it is possible to have a constant compression at the distal end face of the bung while abutting the shoulder portion of the cartridge.

- 25 In another preferred embodiment the first material covers the whole surface of the bung.

To manufacture such a bung comprising at least two different materials, there are many processes that can be used. One example is the sandwich process. There are
30 two melts which are successively die-casted into a cavity by means of a mixing head. The resulting structure is a core-shell structure in case that only two melts are used, or a multi-layer structure in case that more than two melts are used.

In a further preferred embodiment the bung comprises a core and a layer coating the core wherein the layer comprises the first material and the core comprises the second material.

5

By having a thin layer coating the core of the bung the compression of the bung is reduced and thus the bung has also a reduced retention time after compression. This compression results from the pressure of the piston exerted on the bung while the medicinal product is dispensed from the cartridge.

10

In a particularly preferred embodiment the bung is manufactured by injection molding.

One advantage of injection molding is that hard/soft material combinations can be processed at the same time by multi-component injection molding.

15

In another preferred embodiment a cartridge comprises a main body portion, a shoulder portion and a bung wherein the bung is moveable along a longitudinal axis within the main body portion of the cartridge.

20

The texture of the surface material of the bung should enable the bung to be slideable with respect to the cartridge.

In another preferred embodiment the bung abuts the shoulder portion of the cartridge being located at the distal end of the cartridge while expelling the last dose of the

25

medicament from the cartridge.

After dispensing the most of the medicinal product through, for example an adapted needle unit, at the distal end of the cartridge, the bung abuts a narrowing shoulder portion of the cartridge. At this position the bung comes to a stop.

30

Another aspect of the present invention is a drug-delivery device comprising a cartridge and a piston rod actuating a bung. The bung can be axially displaced by a piston.

- 5 By having a bung as it is described here, the drug delivery device is able to dispense a more precise dose of the medicinal product. This is achieved by reduced relaxation times of the bung and more accurate dispensing of the last possible dose of a medicinal product contained in the cartridge.
- 10 In another preferred embodiment a drug delivery device comprises a bung that abuts the shoulder portion being located at the distal end of the cartridge while expelling the last dose of the medicinal product from the cartridge.

In the following the invention is described in further detail with reference to the
15 drawings, wherein

- Figure 1 shows a cross sectional view of a cartridge comprising a bung at a first position at the proximal end of the cartridge, and
- 20 Figure 2 shows a cross sectional view of a cartridge comprising a bung at a second position at the distal end of the cartridge while the bung abuts a narrowing shoulder portion of the cartridge.

Some preferred embodiments of the cartridge and the bung according to the present
25 invention will now be discussed with reference to figure 1 and figure 2. Identical reference signs denote identical or comparable components.

In figure 1 a cross sectional view of a cartridge 10 comprising a bung 20 at a first position is shown. At this position the bung 20 is located at the distal end of the
30 cartridge 14. The cartridge 10 has a main body portion 18, a narrowing shoulder portion 16 and contains a liquid medicinal product.

In this position of the bung 20 it is possible to push the bung 20 in a distal direction by applying a force F onto the bung 20. This can be achieved by a piston, which is not shown in figure 1, located at the proximal end of the cartridge 12.

- 5 The bung 20 shown in figure 1 comprises two different materials and the surface of the bung comprises a lateral area 26, a distal end face 22 and a proximal end face 24. The lateral area 26 of the bung 20 contacts the main body portion 18 of the cartridge 10.

10 In figure 1 a first material 30 which is covering the whole surface of the bung 20, and a second material 32 forming a core which is covered by the first material 30 is shown. The first material 30 has a higher compressibility and is pressed against the inner wall of the main body portion 18 of the cartridge 10 and is therefore able to form a fluid-proof sealing for the medicinal product contained in the cartridge 10.

- 15 In figure 2 a cross sectional view of a cartridge 10 comprising a bung 20 in a second position is shown. In this position the bung 20 abuts a narrowing shoulder portion 16 of the cartridge 10 and is compressed. While applying pressure onto the bung 20 by a piston which is not explicitly shown, the first material 30 at the edge of the distal end face 28 is compressed while abutting the narrowing
20 shoulder portion 16.

25 Due to the special structure, the compression is limited by the layer thickness of the first material 30 at the distal end face of the bung and by the low compressibility of the second material 32 inside the bung 20. By having a flat surface structure at the lateral area 26 of the bung 20, the first material 30 located at the lateral area 26 is not squeezed in proximal direction while being pushed towards the narrowing shoulder portion 16. Due to this, the dose accuracy is increased and the retention time of the bung 20 after compression is decreased.

- 30 If the first material 30 did not have a flat surface structure but a lamellar structure there would be a low resistivity against deformation of the bung 20 while abutting the narrowing shoulder portion 16 of the cartridge 10. By applying the same force onto a

bung with lamellar structure and to a bung 20 with a flat surface structure, the deformation of a lamellar structure is stronger.

The term “drug” or “medicament“, as used herein, means a pharmaceutical formulation
5 containing at least one pharmaceutically active compound,

wherein in one embodiment the pharmaceutically active compound has a molecular weight up to 1500 Da and/or is a peptide, a proteine, a polysaccharide, a vaccine, a DNA, a RNA, a antibody, an enzyme, an antibody, a hormone or an oligonucleotide, or
10 a mixture of the above-mentioned pharmaceutically active compound,

wherein in a further embodiment the pharmaceutically active compound is useful for the treatment and/or prophylaxis of diabetes mellitus or complications associated with diabetes mellitus such as diabetic retinopathy, thromboembolism disorders such as
15 deep vein or pulmonary thromboembolism, acute coronary syndrome (ACS), angina, myocardial infarction, cancer, macular degeneration, inflammation, hay fever, atherosclerosis and/or rheumatoid arthritis,

wherein in a further embodiment the pharmaceutically active compound comprises at
20 least one peptide for the treatment and/or prophylaxis of diabetes mellitus or complications associated with diabetes mellitus such as diabetic retinopathy,

wherein in a further embodiment the pharmaceutically active compound comprises at least one human insulin or a human insulin analogue or derivative, glucagon-like peptide (GLP-1) or an analogue or derivative thereof, or exedin-3 or exedin-4 or an
25 analogue or derivative of exedin-3 or exedin-4.

Insulin analogues are for example Gly(A21), Arg(B31), Arg(B32) human insulin; Lys(B3), Glu(B29) human insulin; Lys(B28), Pro(B29) human insulin; Asp(B28) human
30 insulin; human insulin, wherein proline in position B28 is replaced by Asp, Lys, Leu, Val or Ala and wherein in position B29 Lys may be replaced by Pro; Ala(B26) human

insulin; Des(B28-B30) human insulin; Des(B27) human insulin and Des(B30) human insulin.

Insulin derivatives are for example B29-N-myristoyl-des(B30) human insulin; B29-N-palmitoyl-des(B30) human insulin; B29-N-myristoyl human insulin; B29-N-palmitoyl human insulin; B28-N-myristoyl LysB28ProB29 human insulin; B28-N-palmitoyl-LysB28ProB29 human insulin; B30-N-myristoyl-ThrB29LysB30 human insulin; B30-N-palmitoyl-ThrB29LysB30 human insulin; B29-N-(N-palmitoyl-Y-glutamyl)-des(B30) human insulin; B29-N-(N-lithocholyl-Y-glutamyl)-des(B30) human insulin; B29-N-(ω -carboxyheptadecanoyl)-des(B30) human insulin and B29-N-(ω -carboxyheptadecanoyl) human insulin.

Exendin-4 for example means Exendin-4(1-39), a peptide of the sequence H-His-Gly-Glu-Gly-Thr-Phe-Thr-Ser-Asp-Leu-Ser-Lys-Gln-Met-Glu-Glu-Glu-Ala-Val-Arg-Leu-Phe-Ile-Glu-Trp-Leu-Lys-Asn-Gly-Gly-Pro-Ser-Ser-Gly-Ala-Pro-Pro-Pro-Ser-NH₂.

Exendin-4 derivatives are for example selected from the following list of compounds:

H-(Lys)₄-des Pro₃₆, des Pro₃₇ Exendin-4(1-39)-NH₂,
 20 H-(Lys)₅-des Pro₃₆, des Pro₃₇ Exendin-4(1-39)-NH₂,
 des Pro₃₆ [Asp₂₈] Exendin-4(1-39),
 des Pro₃₆ [IsoAsp₂₈] Exendin-4(1-39),
 des Pro₃₆ [Met(O)₁₄, Asp₂₈] Exendin-4(1-39),
 des Pro₃₆ [Met(O)₁₄, IsoAsp₂₈] Exendin-4(1-39),
 25 des Pro₃₆ [Trp(O₂)₂₅, Asp₂₈] Exendin-4(1-39),
 des Pro₃₆ [Trp(O₂)₂₅, IsoAsp₂₈] Exendin-4(1-39),
 des Pro₃₆ [Met(O)₁₄ Trp(O₂)₂₅, Asp₂₈] Exendin-4(1-39),
 des Pro₃₆ [Met(O)₁₄ Trp(O₂)₂₅, IsoAsp₂₈] Exendin-4(1-39); or
 30 des Pro₃₆ [Asp₂₈] Exendin-4(1-39),
 des Pro₃₆ [IsoAsp₂₈] Exendin-4(1-39),
 des Pro₃₆ [Met(O)₁₄, Asp₂₈] Exendin-4(1-39),

des Pro36 [Met(O)14, IsoAsp28] Exendin-4(1-39),

des Pro36 [Trp(O2)25, Asp28] Exendin-4(1-39),

des Pro36 [Trp(O2)25, IsoAsp28] Exendin-4(1-39),

des Pro36 [Met(O)14 Trp(O2)25, Asp28] Exendin-4(1-39),

5 des Pro36 [Met(O)14 Trp(O2)25, IsoAsp28] Exendin-4(1-39),

wherein the group -Lys6-NH₂ may be bound to the C-terminus of the Exendin-4 derivative;

or an Exendin-4 derivative of the sequence

10 H-(Lys)6-des Pro36 [Asp28] Exendin-4(1-39)-Lys6-NH₂,

des Asp28 Pro36, Pro37, Pro38 Exendin-4(1-39)-NH₂,

H-(Lys)6-des Pro36, Pro38 [Asp28] Exendin-4(1-39)-NH₂,

H-Asn-(Glu)5des Pro36, Pro37, Pro38 [Asp28] Exendin-4(1-39)-NH₂,

des Pro36, Pro37, Pro38 [Asp28] Exendin-4(1-39)-(Lys)6-NH₂,

15 H-(Lys)6-des Pro36, Pro37, Pro38 [Asp28] Exendin-4(1-39)-(Lys)6-NH₂,

H-Asn-(Glu)5-des Pro36, Pro37, Pro38 [Asp28] Exendin-4(1-39)-(Lys)6-NH₂,

H-(Lys)6-des Pro36 [Trp(O2)25, Asp28] Exendin-4(1-39)-Lys6-NH₂,

H-des Asp28 Pro36, Pro37, Pro38 [Trp(O2)25] Exendin-4(1-39)-NH₂,

H-(Lys)6-des Pro36, Pro37, Pro38 [Trp(O2)25, Asp28] Exendin-4(1-39)-NH₂,

20 H-Asn-(Glu)5-des Pro36, Pro37, Pro38 [Trp(O2)25, Asp28] Exendin-4(1-39)-NH₂,

des Pro36, Pro37, Pro38 [Trp(O2)25, Asp28] Exendin-4(1-39)-(Lys)6-NH₂,

H-(Lys)6-des Pro36, Pro37, Pro38 [Trp(O2)25, Asp28] Exendin-4(1-39)-(Lys)6-NH₂,

H-Asn-(Glu)5-des Pro36, Pro37, Pro38 [Trp(O2)25, Asp28] Exendin-4(1-39)-(Lys)6-NH₂,

25 H-(Lys)6-des Pro36 [Met(O)14, Asp28] Exendin-4(1-39)-Lys6-NH₂,

des Met(O)14 Asp28 Pro36, Pro37, Pro38 Exendin-4(1-39)-NH₂,

H-(Lys)6-des Pro36, Pro37, Pro38 [Met(O)14, Asp28] Exendin-4(1-39)-NH₂,

H-Asn-(Glu)5-des Pro36, Pro37, Pro38 [Met(O)14, Asp28] Exendin-4(1-39)-NH₂,

des Pro36, Pro37, Pro38 [Met(O)14, Asp28] Exendin-4(1-39)-(Lys)6-NH₂,

30 H-(Lys)6-des Pro36, Pro37, Pro38 [Met(O)14, Asp28] Exendin-4(1-39)-(Lys)6-NH₂,

H-Asn-(Glu)5 des Pro36, Pro37, Pro38 [Met(O)14, Asp28] Exendin-4(1-39)-(Lys)6-NH₂,

H-Lys6-des Pro36 [Met(O)14, Trp(O2)25, Asp28] Exendin-4(1-39)-Lys6-NH2,
H-des Asp28 Pro36, Pro37, Pro38 [Met(O)14, Trp(O2)25] Exendin-4(1-39)-NH2,
H-(Lys)6-des Pro36, Pro37, Pro38 [Met(O)14, Asp28] Exendin-4(1-39)-NH2,
H-Asn-(Glu)5-des Pro36, Pro37, Pro38 [Met(O)14, Trp(O2)25, Asp28] Exendin-4(1-
5 39)-NH2,
des Pro36, Pro37, Pro38 [Met(O)14, Trp(O2)25, Asp28] Exendin-4(1-39)-(Lys)6-NH2,
H-(Lys)6-des Pro36, Pro37, Pro38 [Met(O)14, Trp(O2)25, Asp28] Exendin-4(S1-39)-
(Lys)6-NH2,
H-Asn-(Glu)5-des Pro36, Pro37, Pro38 [Met(O)14, Trp(O2)25, Asp28] Exendin-4(1-
10 39)-(Lys)6-NH2;

or a pharmaceutically acceptable salt or solvate of any one of the afore-mentioned Exedin-4 derivative.

15 Hormones are for example hypophysis hormones or hypothalamus hormones or regulatory active peptides and their antagonists as listed in Rote Liste, ed. 2008, Chapter 50, such as Gonadotropine (Follitropin, Lutropin, Choriogonadotropin, Menotropin), Somatropine (Somatropin), Desmopressin, Terlipressin, Gonadorelin, Triptorelin, Leuprorelin, Buserelin, Nafarelin, Goserelin.

20

A polysaccharide is for example a glucosaminoglycane, a hyaluronic acid, a heparin, a low molecular weight heparin or an ultra low molecular weight heparin or a derivative thereof, or a sulphated, e.g. a poly-sulphated form of the above-mentioned polysaccharides, and/or a pharmaceutically acceptable salt thereof. An example of a
25 pharmaceutically acceptable salt of a poly-sulphated low molecular weight heparin is enoxaparin sodium.

Pharmaceutically acceptable salts are for example acid addition salts and basic salts. Acid addition salts are e.g. HCl or HBr salts. Basic salts are e.g. salts having a cation
30 selected from alkali or alkaline, e.g. Na⁺, or K⁺, or Ca²⁺, or an ammonium ion N⁺(R1)(R2)(R3)(R4), wherein R1 to R4 independently of each other mean: hydrogen, an optionally substituted C1-C6-alkyl group, an optionally substituted C2-C6-alkenyl

group, an optionally substituted C6-C10-aryl group, or an optionally substituted C6-C10-heteroaryl group. Further examples of pharmaceutically acceptable salts are described in "Remington's Pharmaceutical Sciences" 17. ed. Alfonso R. Gennaro (Ed.), Mark Publishing Company, Easton, Pa., U.S.A., 1985 and in Encyclopedia of
5 Pharmaceutical Technology.

Pharmaceutically acceptable solvates are for example hydrates.

Reference numerals

- 10 cartridge
- 12 proximal end of the cartridge
- 5 14 distal end of the cartridge
- 16 shoulder portion
- 18 main body portion
- 20 bung
- 22 distal end face
- 10 24 proximal end face
- 26 lateral area
- 28 edge of the distal end face
- 30 first material
- 32 second material
- 15 F force

Claims

- 5 1. A bung (20) for drug containing cartridges (10) for use in drug delivery devices wherein the bung (20) has a distal end face (22), a proximal end face (24) and a lateral area (26), wherein the bung (20) comprises at least two different materials, a first material (30) covering the whole lateral area (26) of the bung (20) and a second material (32) which is at least partly arranged inside the bung (20), wherein the first material (30) has a larger compressibility than the second
10 material (32) and wherein the whole lateral area (26) has a flat surface.
2. A bung (20) according to claim 1, wherein the second material (32) comprises metal.
- 15 3. A bung (20) according to anyone of the previous claims, wherein the second material (32) comprises ceramic.
4. A bung (20) according to anyone of the previous claims, wherein the second
20 material (32) comprises a polymer matrix.
5. A bung (20) according to anyone of the previous claims, wherein the first material (30) comprises rubber.
- 25 6. A bung (20) according to anyone of the previous claims, wherein the first material (30) arranged at the lateral area (26) together with the shape of the bung enables the bung (20) to seal a proximal end of a drug containing cartridge (12).
- 30 7. A bung (20) according to anyone of the previous claims, wherein the first material (30) covers the distal end face (22) of the bung (20).

8. A bung (20) according to anyone of the previous claims, wherein the distal end face (22) of the bung has a flat surface.
9. A bung (20) according to anyone of the previous claims, wherein the first material (30) covers the whole surface of the bung (20).
5
10. A bung (20) according to anyone of the previous claims, wherein the bung (20) comprises a core and a layer coating the core, wherein the layer comprises the first material (30) and the core comprises the second material (32).
10
11. A bung (20) according to anyone of the previous claims, wherein the bung (20) is manufactured by injection molding.
12. A cartridge (10) comprising a main body portion (18), a shoulder portion (16) and a bung (20) according to anyone of the previous claims, wherein the bung (20) is moveable along a longitudinal axis within the main body portion (18) of the cartridge (10).
15
13. A cartridge (10) according to claim 12, wherein the bung (20) abuts the shoulder portion (16) being located at the distal end of the cartridge (14) while expelling the last dose of the medicament from the cartridge (10).
20
14. A drug delivery device comprising a cartridge (10) according to claim 12 or 13 and a piston rod actuating the bung (20).
25
15. A drug delivery device comprising a cartridge (10) with a bung (20) according to claim 13, wherein the bung (20) abuts the shoulder portion (16) being located at the distal end of the cartridge (14) while expelling the last dose of the medicament from the cartridge (10).
30

FIG 1

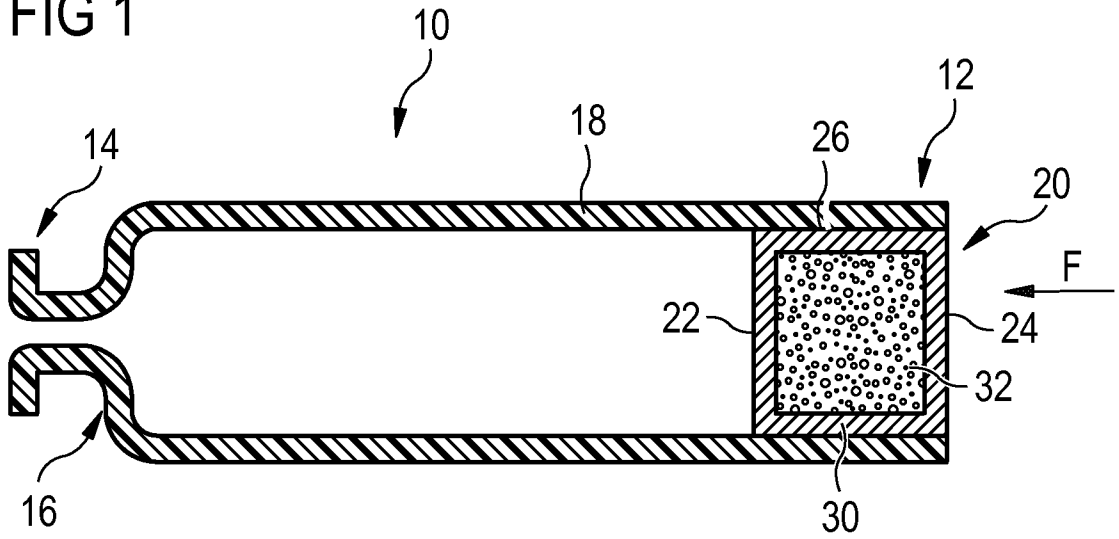
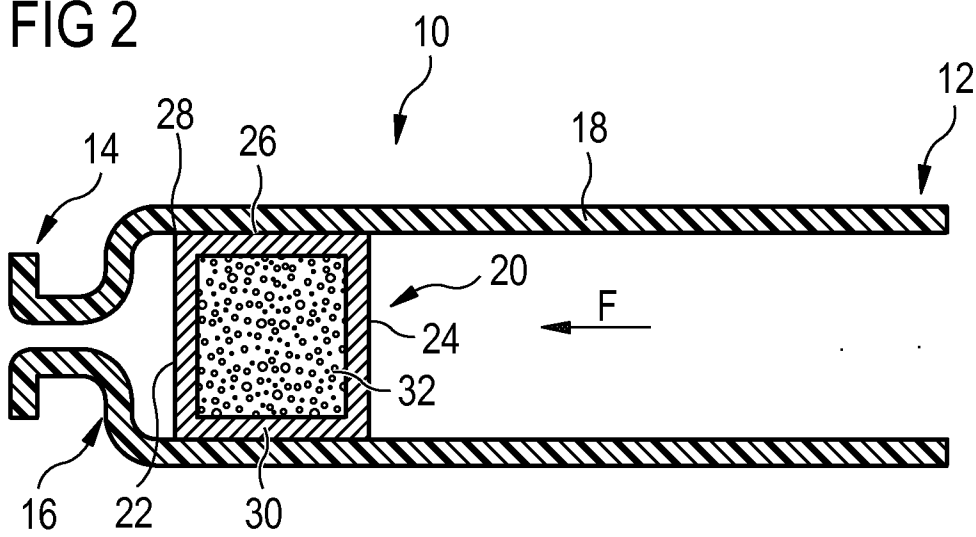

FIG 2



INTERNATIONAL SEARCH REPORT

International application No
PCT/EP2010/056977

A. CLASSIFICATION OF SUBJECT MATTER
 INV. A61M5/315
 ADD.

According to International Patent Classification (IPC) or to both national classification and IPC

B. FIELDS SEARCHED

Minimum documentation searched (classification system followed by classification symbols)
A61M

Documentation searched other than minimum documentation to the extent that such documents are included in the fields searched

Electronic data base consulted during the international search (name of data base and, where practical, search terms used)
EPO-Internal

C. DOCUMENTS CONSIDERED TO BE RELEVANT

Category*	Citation of document, with indication, where appropriate, of the relevant passages	Relevant to claim No.
X	GB 578 827 A (SELWYN HENRY WINTER) 12 July 1946 (1946-07-12) the whole document	1-15
X	US 2 607 342 A (ABEL MARTIN S) 19 August 1952 (1952-08-19) column 2, line 54 - column 3, line 14; figures 1-2	1-4,6-15
Y	EP 0 743 072 A2 (BECTON DICKINSON CO [US]) 20 November 1996 (1996-11-20) column 5, lines 13-18; figures 1-2	1-15
	----- -/--	

Further documents are listed in the continuation of Box C. See patent family annex.

* Special categories of cited documents :

<p>"A" document defining the general state of the art which is not considered to be of particular relevance</p> <p>"E" earlier document but published on or after the international filing date</p> <p>"L" document which may throw doubts on priority claim(s) or which is cited to establish the publication date of another citation or other special reason (as specified)</p> <p>"O" document referring to an oral disclosure, use, exhibition or other means</p> <p>"P" document published prior to the international filing date but later than the priority date claimed</p>	<p>"T" later document published after the international filing date or priority date and not in conflict with the application but cited to understand the principle or theory underlying the invention</p> <p>"X" document of particular relevance; the claimed invention cannot be considered novel or cannot be considered to involve an inventive step when the document is taken alone</p> <p>"Y" document of particular relevance; the claimed invention cannot be considered to involve an inventive step when the document is combined with one or more other such documents, such combination being obvious to a person skilled in the art.</p> <p>"&" document member of the same patent family</p>
--	--

Date of the actual completion of the international search 19 July 2010	Date of mailing of the international search report 26/07/2010
--	---

Name and mailing address of the ISA/ European Patent Office, P.B. 5818 Patentlaan 2 NL - 2280 HV Rijswijk Tel. (+31-70) 340-2040, Fax: (+31-70) 340-3016	Authorized officer Björklund, Andreas
--	---

INTERNATIONAL SEARCH REPORT

International application No

PCT/EP2010/056977

C(Continuation). DOCUMENTS CONSIDERED TO BE RELEVANT		
Category*	Citation of document, with indication, where appropriate, of the relevant passages	Relevant to claim No.
Y	WO 2005/099793 A1 (LILLY CO ELI [US]; DAI HE [US]; ALLEN DOUGLAS JAMES [US]) 27 October 2005 (2005-10-27) cited in the application page 4, line 14 - page 5, line 16; figures 1-6	1-15
A	US 2003/233075 A1 (HUEGLI SERGE [CH]) 18 December 2003 (2003-12-18) paragraph [0050]; figures 1-9	2-4

INTERNATIONAL SEARCH REPORT

Information on patent family members

International application No PCT/EP2010/056977
--

Patent document cited in search report	Publication date	Patent family member(s)	Publication date
GB 578827	A	NONE	
US 2607342	A	NONE	
EP 0743072	A2	20-11-1996	
		CA 2174999 A1	20-11-1996
		DE 69605710 D1	27-01-2000
		DE 69605710 T2	27-04-2000
		EP 0935970 A1	18-08-1999
		JP 3200015 B2	20-08-2001
		JP 8317975 A	03-12-1996
		US 5607400 A	04-03-1997
WO 2005099793	A1	27-10-2005	
		EP 1735032 A1	27-12-2006
		JP 2007532181 T	15-11-2007
		US 2007219507 A1	20-09-2007
US 2003233075	A1	18-12-2003	
		DE 10226643 A1	15-01-2004