

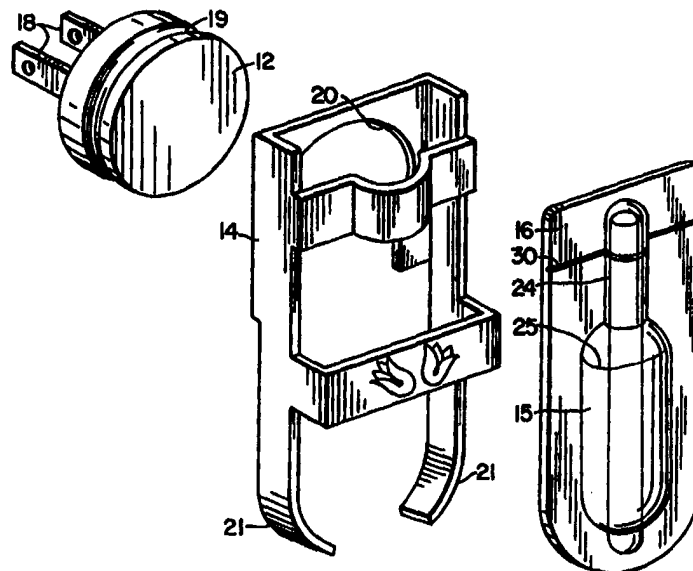

INTERNATIONAL APPLICATION PUBLISHED UNDER THE PATENT COOPERATION TREATY (PCT)

<p>(51) International Patent Classification⁶ : A61L 9/03</p>	<p>A1</p>	<p>(11) International Publication Number: WO 98/46284</p> <p>(43) International Publication Date: 22 October 1998 (22.10.98)</p>
<p>(21) International Application Number: PCT/US98/07737</p> <p>(22) International Filing Date: 14 April 1998 (14.04.98)</p> <p>(30) Priority Data: 08/837,194 14 April 1997 (14.04.97) US</p> <p>(71) Applicant: S. C. JOHNSON & SON, INC. [US/US]; 1525 Howe Street, Racine, WI 53403 (US).</p> <p>(72) Inventors: MARTIN, John; 5305 Santa Anita Drive, Racine, WI 53402 (US). WEFLER, Mark, E.; 4937 High Meadows Terrace, Racine, WI 53406 (US).</p> <p>(74) Agents: FRANK, J., William, III et al.; S. C. Johnson & Son, Inc., Patent Section, 1525 Howe Street, Racine, WI 53403 (US).</p>		<p>(81) Designated States: AU, BR, CN, JP, KR, MX, NZ, European patent (AT, BE, CH, CY, DE, DK, ES, FI, FR, GB, GR, IE, IT, LU, MC, NL, PT, SE).</p> <p>Published <i>With international search report. Before the expiration of the time limit for amending the claims and to be republished in the event of the receipt of amendments.</i></p>

(54) Title: LIQUID AIR FRESHENER DISPENSER DEVICE WITH DISPOSABLE WICKING CARTRIDGE UNIT



(57) Abstract

This invention provides an air freshener dispenser device (10) which is an assembly of structural units comprising 1) a disposable cartridge (15) and 2) a plug-in type of heater module (12). The cartridge has an elongated thermoplastic hollow body configuration with a sealed internal reservoir chamber of liquid air freshener medium (25), and the upper end of the cartridge has a narrow stem extension of the internal chamber. An elongated wick (24) extends from the chamber bottom up to the top of the stem extension. The top portion (16) of the stem extension is designed for manual detachment to expose the top section of the wick. In a preferred embodiment a support frame (14) is incorporated to support the disposable cartridge. The support frame is detachably secured to the heater module. The heating module and cartridge stem extension are proximate for heat-activated promotion of air freshener wicking into the atmosphere.

FOR THE PURPOSES OF INFORMATION ONLY

Codes used to identify States party to the PCT on the front pages of pamphlets publishing international applications under the PCT.

AL	Albania	ES	Spain	LS	Lesotho	SI	Slovenia
AM	Armenia	FI	Finland	LT	Lithuania	SK	Slovakia
AT	Austria	FR	France	LU	Luxembourg	SN	Senegal
AU	Australia	GA	Gabon	LV	Latvia	SZ	Swaziland
AZ	Azerbaijan	GB	United Kingdom	MC	Monaco	TD	Chad
BA	Bosnia and Herzegovina	GE	Georgia	MD	Republic of Moldova	TG	Togo
BB	Barbados	GH	Ghana	MG	Madagascar	TJ	Tajikistan
BE	Belgium	GN	Guinea	MK	The former Yugoslav Republic of Macedonia	TM	Turkmenistan
BF	Burkina Faso	GR	Greece	ML	Mali	TR	Turkey
BG	Bulgaria	HU	Hungary	MN	Mongolia	TT	Trinidad and Tobago
BJ	Benin	IE	Ireland	MR	Mauritania	UA	Ukraine
BR	Brazil	IL	Israel	MW	Malawi	UG	Uganda
BY	Belarus	IS	Iceland	MX	Mexico	US	United States of America
CA	Canada	IT	Italy	NE	Niger	UZ	Uzbekistan
CF	Central African Republic	JP	Japan	NL	Netherlands	VN	Viet Nam
CG	Congo	KE	Kenya	NO	Norway	YU	Yugoslavia
CH	Switzerland	KG	Kyrgyzstan	NZ	New Zealand	ZW	Zimbabwe
CI	Côte d'Ivoire	KP	Democratic People's Republic of Korea	PL	Poland		
CM	Cameroon	KR	Republic of Korea	PT	Portugal		
CN	China	KZ	Kazakstan	RO	Romania		
CU	Cuba	LC	Saint Lucia	RU	Russian Federation		
CZ	Czech Republic	LI	Liechtenstein	SD	Sudan		
DE	Germany	LK	Sri Lanka	SE	Sweden		
DK	Denmark	LR	Liberia	SG	Singapore		
EE	Estonia						

-1-

LIQUID AIR FRESHENER DISPENSER DEVICE
WITH DISPOSABLE WICKING CARTRIDGE UNIT

TECHNICAL FIELD

5 This invention generally relates to dispensers of vaporizable media. More specifically, this invention relates to a device for dispensing a fragrance or deodorant in the form of a vapor for air freshening in an enclosed environment.

BACKGROUND ART

The need for effectively combating airborne malodors in homes and enclosed
10 public buildings, by odor masking or destruction, is well established. Various kinds of vapor-dispensing devices have been employed for this purpose. The most common of such devices is the aerosol container which propels minute droplets of an air freshener composition into the air. Another common type of dispensing device is a dish containing or supporting a body of gelatinous matter which when it dries and
15 shrinks releases a vaporized air-treating composition into the atmosphere. Other products such as deodorant blocks are also used for dispensing air-treating vapors into the atmosphere by evaporation. Another group of vapor-dispensing devices utilizes a carrier material such as paperboard impregnated or coated with a vaporizable composition.

20 A number of recent developments include a liquid air-treating composition in an enclosure, all or part of which is formed of a polymeric film through which the air-treating composition can migrate to be released as a vapor at an outer surface. Use of this type of permeable polymeric membrane controls the dispensing of air-treating vapors and tends to eliminate great variations in the rate of dispensing over the life of
25 the product.

Wicking devices are well known for dispensing volatile liquids into the atmosphere, such as fragrance, deodorant, disinfectant or insecticide active agent.

A typical wicking device utilizes a combination of a wick and emanating region to dispense a volatile liquid from a liquid reservoir. Wicking devices are
30 described in United States Patent Numbers 1,994,932; 2,597,195; 2,802,695;

-2-

2,804,291; 3,550,853; 4,286,754; 4,413,779; 4,454,987; 4,913,350; and 5,000,383; incorporated by reference.

Of special interest with respect to the present invention are wicking dispenser devices in which the wicking action is promoted by a heat source. This type of wicking device is described in United States Patent Numbers 3,288,556; 3,431,393; 3,482,929; 3,633,881; 4,020,321; 4,968,487; 5,038,394; 5,290,546; and 5,364,027; incorporated by reference.

Some air freshener dispensers are expensive to manufacture. Other air freshener dispensers are inexpensive to produce, but tend to have inferior construction and functionality.

There remains a need for a well-constructed air freshener dispenser device which can be mass-produced economically and which can deliver a vapor medium at a controlled uniform rate over an extended period of time.

Accordingly, it is an object of this invention to provide an improved air freshener dispenser device for delivering an odorant and/or deodorant vapor in an enclosed environment.

It is another object of this invention to provide an air freshener dispenser device with an assembly of plastic structures which can be produced economically by extrusion or thermoforming means.

It is another object of this invention to provide an air freshener dispenser device which has an interactive combination of heater module and disposable cartridge unit.

It is a further object of this invention to provide a disposable cartridge for utility in a heat-activated air freshener dispenser device, wherein the cartridge has an internal air freshener reservoir in contact with an elongated slender wick.

Other objects and advantages of the present invention shall become apparent from the accompanying description and drawings.

SUMMARY OF THE INVENTION

One or more objects of the present invention are accomplished by the provision of an air freshener dispenser device which is adapted for engagement and

support by a wall electrical outlet, and which is an assembly of structural units comprising

- (1) a disposable cartridge having
 - (a) an elongated thermoplastic hollow body configuration with a sealed internal reservoir chamber of liquid air freshener medium, and the upper end of the cartridge has a narrow stem extension of the internal chamber,
 - (b) an elongated wick which extends from the chamber bottom up to the top of the stem extension, and
 - (c) integrally structured means adapted for removal of a top portion of the cartridge stem extension to expose an upper section of the wick to the atmosphere; and
- (2) a heater means which is detachably secured and positioned proximate to the said cartridge stem extension for promotion of air freshener wicking into the atmosphere.

In another embodiment this invention provides an air freshener dispenser device which is adapted for engagement and support by a wall electrical outlet, and which is an assembly of structural units comprising

- (1) a disposable cartridge having
 - (a) an elongated thermoplastic hollow body configuration with a sealed internal reservoir chamber of liquid air freshener medium, and the upper end of the cartridge has a narrow stem extension of the internal chamber,
 - (b) an elongated wick which extends from the chamber bottom up to the top of the stem extension, and
 - (c) integrally structured means adapted for removal of a top portion of the cartridge stem extension to expose an upper section of the wick to the atmosphere;
- (2) a plug-in heater module; and

-4-

- (3) a support frame which is adapted to support the disposable cartridge, wherein the support frame is detachably secured to the heater module, and the support frame maintains the supported cartridge in a vertical position with the cartridge stem extension proximate to the heater module for promotion of air freshener wicking into the atmosphere.

DESCRIPTION OF THE DRAWINGS

FIG. 1 is a composite prospective view of an invention air freshener dispenser device.

FIG. 2 is a side elevation view of an invention device plug-in electrical-resistance heater module.

FIG. 3 is a perspective front view of an assembled invention device support frame and disposable cartridge.

FIG. 4 is a perspective rear view of the FIG. 3 support frame.

FIG. 5 is a perspective front view of an alternative structural design for an invention device support frame for an invention disposable cartridge.

FIG. 6 is a front elevational view of an invention air freshener dispenser device.

FIG. 7 is a cross-sectional view taken along lines 7-7 of FIG. 6.

FIG. 8 is a cross-sectional side view of an invention disposable cartridge unit.

FIG. 9 is a front elevational view of an invention disposable cartridge unit.

FIG. 10 is a cross-sectional view taken along lines 10-10 of FIG. 9.

FIG. 11 is the FIG. 9 front elevational view with the top portion of the cartridge removed.

BEST MODE FOR CARRYING OUT THE INVENTION

FIG. 1 illustrates an exploded view of present invention air freshener device 10.

In assembled form, air freshener device 10 is plugged into a wall electrical socket by means of twin prongs 18 of heater module 12, and electric current is conducted to an electrical-resistance heating element which is embedded in heater

-5-

module 12. Support frame 14 securely maintains cartridge 15 in a vertical position with the cartridge 15 stem extension proximate to heater module 12 for promotion of air freshener wicking out of cartridge 15 into the atmosphere, after removal of top portion 16 of the stem extension to expose the top section of the internally disposed
5 elongated wick (not shown in FIG. 1).

FIG. 2 is a side elevation view of heater module 12, with metal prongs 18, and structural recess 19 which secures heater module 12 to support frame 14.

Heater module 12 is a commercially available type of plug-in heater product. The metal prongs and connected electrical-resistance heating element are embedded in
10 a molded plastic matrix. Illustrated heated module 12 has a front heating surface diameter of about 0.5-1.5 inches.

Another type of plug-in heater product has a similar construction, except that the electrical- resistance heating element is in the form of a film coating or printed pattern on the front heating surface. These types of electrical-resistance heating
15 elements are described in publications such as United States Patent Numbers 3,067,310; 3,266,661; 4,849,255; 4,857,384; 4,912,306; 4,935,156; 5,106,540; 5,382,384; and 5,415,934; incorporated by reference.

FIG. 3 and FIG. 4 are prospective front and back views of support frame 14, with extended side panels 21, and cut-out opening 20 which is adapted to snap-in to
20 recess 19 of heater module 12 in FIG. 2. Support frame 14 is detachably and rotatably secured to heater module 12, so that support frame 14 and supported disposable cartridge 15 are adjustable to a vertical position for any orientation of wall electrical outlet.

FIG. 5 is an alternative design for a FIG. 4 type of support frame 14 for
25 disposable cartridge 15. Opening slot 23 permits a view of liquid air freshener 25 in cartridge 15 (not shown in FIG. 5). Support frame 14 in FIG. 5 can have other structural configurations, and the front expanse can have a decorative design and/or logo on the surface.

Support frame 14 is a semi-rigid or rigid housing preferably constructed of a
30 molded thermoplastic polymer such as polypropylene or polystyrene. Other suitable

-6-

construction materials include thermoset resins, metals, cellulose, and the like. The dimensions of support frame 14 are suitably selected for conformation with heater module 12 and disposable cartridge 15.

FIG. 6 is a front elevational view of air freshener dispenser device 10, with
5 disposable cartridge 15 positioned in support frame 14. The combination of disposable cartridge 15 and support frame 14 is detachably and rotatably secured to heater module 12 (not shown). Heater module 12 extends rearwardly horizontal from support frame 14, with metal prongs 18 positioned for engagement with a wall electrical outlet.

10 FIG. 7 is a cross-sectional view taken along lines 7-7 of FIG. 6, with heater module 12 secured to the combination of support frame 14 and disposable cartridge 15. Air passages within and around dispenser device 10 permit convected air flow upwardly past the heated stem extension of cartridge 15 and exposed upper section of the interior wick (not shown) when top portion 16 of the cartridge stem extension is
15 manually removed.

FIG. 8 is a cross-sectional side view of disposable cartridge 15, with capillary wick 24 in a vertically disposed position within the reservoir chamber of disposable cartridge 15, and in contact with liquid air freshener medium 25.

Disposable cartridge 15 can be constructed by either injection or thermoform
20 molding of a thermoplastic polymer such as polyethylene, polypropylene, polystyrene, polyvinyl chloride, polyvinyl acetate, polyamide, polymethacrylate, and the like. In one method the hollow body of disposable cartridge 15 of FIG. 8 is constructed of sealed juxtapositioned sections of molded vapor-impermeable polyvinyl thin film, with an opening in the bottom periphery. The bottom opening is
25 utilized for introducing air freshener medium 25 and wick 24 into the reservoir chamber of disposable cartridge 15, after which the opening is heat-sealed.

Wick 24 in FIG. 8 normally is in the shape of an elongated flat-sided or annular body with an interconnected porosity for liquid capillary action. Wick 24 is a porous matrix which is composed of inorganic or organic materials such as ceramic,

plastic and cellulosic compositions. Wick 24 alternatively can be in the form of a fibrous aggregate or a grooved nonporous rod.

A variety of wick compositions and structures suitable for air freshener dispenser devices are described in United States Patent Numbers 3,431,393; 5 3,482,929; 3,633,881; 4,020,321, 4,968,487; 5,038,394; and 5,290,546; incorporated by reference.

Air freshener medium 25 in FIG. 8 can be any air treating material which can migrate up capillary wick 24 and disperse into the atmosphere in vapor form.

Typically air freshener medium 25 is a fragrance or a deodorant in liquid form.

10 Preferably, air freshener medium 25 is a liquid fragrance comprising one or more volatile organic compounds which are available from perfumery suppliers such as Firmenich Inc., Takasago Inc., Noville Inc., Quest Co., and Givaudan-Roure Corp.

Most conventional fragrance materials are volatile essential oils. The fragrance can be a synthetically formed material, or a naturally derived oil such as oil 15 of Bergamot, Bitter Orange, Lemon, Mandarin, Caraway, Cedar Leaf, Clove Leaf, Cedar Wood, Geranium, Lavender, Orange, Origanum, Petitgrain, White Cedar, Patchouli, Lavandin, Neroli, Rose absolute, and the like.

A wide variety of chemicals are known for perfumery, such as aldehydes, ketones, esters, alcohols, terpenes, and the like. A fragrance can be relatively simple 20 in composition, or can be a complex mixture of natural and synthetic chemical components.

A typical scented oil can comprise woody/earthy bases containing exotic constituents such as sandalwood oil, civet, patchouli oil, and the like. A scented oil can have a light floral fragrance, such as rose extract or violet extract. Scented oil 25 also can be formulated to provide desirable fruity odors, such as lime, lemon or orange.

Synthetic types of fragrance compositions either alone or in combination with natural oils are described in United States Patents 4,314,915; 4,411,829; and 4,434,306; incorporated herein by reference. Other artificial liquid fragrances include

-8-

geraniol, geranyl acetate, eugenol, isoeugenol, linalool, linalyl acetate, phenethyl alcohol, methyl ethyl ketone, methylionone, isobornyl acetate, and the like.

FIG. 9 is a front elevational view of disposable cartridge 15 which illustrates additional structural features. If disposable cartridge 15 is constructed with a flexible thermoplastic thin film, structural reinforcement of the thin film shape can be
5 accomplished by forming centrally disposed rib 27 during the thin film molding stage.

An important feature of disposable cartridge 15 in FIG. 9 is detachable portion 16 of the cartridge stem extension, which is adapted for removal by a manual twisting force. The removal of portion 16 is for the purpose of exposing the upper section of
10 wick 24 to the atmosphere. Demarcation 30 is a scored or spaced detachment line.

FIG. 10 is a cross-sectional view taken along lines 10-10 of FIG. 9, which illustrates the disposition of wick 24, and air freshener medium 25 in disposable cartridge 15, and recessed rib 27.

It is preferred that cartridge 15 of FIG. 9 and FIG. 10 is constructed with at
15 least one thermoplastic section which has optical transparency, and interior air freshener medium 25 is visible.

FIG. 11 is the FIG. 9 front elevation view with top portion 16 detached, and upper section 32 of wick 24 exposed to the atmosphere.

Disposable cartridge 15 of a present invention air freshener device can be
20 produced in high volume from relatively inexpensive plastic materials. After usage, the cartridge qualifies for disposal as a non-hazardous solid waste.

INDUSTRIAL APPLICABILITY

The units of this invention may be used as low cost volatile dispensing devices for both fragrances and or insect active compounds.

WHAT IS CLAIMED IS:

1. An air freshener dispenser device which is adapted for engagement and support by a wall electrical outlet, and which is an assembly of structural units comprising
- (1) a disposable cartridge having
 - 5 (a) an elongated thermoplastic hollow body configuration with a sealed internal reservoir chamber of liquid air freshener medium, and the upper end of the cartridge has a narrow stem extension of the internal chamber,
 - 10 (b) an elongated wick which extends from the chamber bottom up to the top of the stem extension, and
 - (c) integrally structured means adapted for removal of a top portion of the cartridge stem extension to expose an upper section of the wick to the atmosphere; and
 - 15 (2) a heater means which is detachably secured and positioned proximate to the said cartridge stem extension for promotion of air freshener wicking into the atmosphere.
2. A dispenser device in accordance with claim 1 wherein the hollow body of the cartridge is a construction of sealed juxtapositioned sections of molded vapor-impermeable polyvinyl thin film.
- 20 3. A dispenser device in accordance with claim 2 wherein the thermoplastic thin film sections have one or more structurally integrated rib support means to resist flexing of the said thin film sections by external pressure.
- 25 4. A dispenser device in accordance with claim 2 wherein at least one of the thermoplastic thin film sections has optical transparency, and the interior liquid air freshener content is visible.
- 30 5. A dispenser device in accordance with claim 1 wherein the wick is a porous matrix selected from the group consisting of ceramic, plastic and cellulosic compositions.

-10-

6. A dispenser device in accordance with claim 1 wherein the integrally structured means for removal of the top portion of the cartridge stem extension consists of the top portion with a scored or spaced detachment demarcation which facilitates manual
5 removal of the said top portion.
7. A dispenser device in accordance with claim 1 wherein the heater means comprises a molded plastic plug with a front heating section which contains an embedded electrical-resistance heating element, and with a pair of prongs extending rearwardly
10 from the plug for engagement with a wall electrical outlet, and said prongs are adapted to conduct electric current to the electrical-resistance heating element.
8. A dispenser device in accordance with claim 7 wherein the plastic plug electrical-resistance heating element is in the form of a film coating or printed pattern on the
15 front heating surface of the plug.
9. A dispenser device in accordance with claim 1 wherein the liquid air freshener medium is a fragrance formulation.
- 20 10. An air freshener dispenser device which is adapted for engagement and support by a wall electrical outlet, and which is an assembly of structural units comprising
(1) a disposable cartridge having

-11-

- (a) an elongated thermoplastic hollow body configuration with a sealed internal reservoir chamber of liquid air freshener medium, and the upper end of the cartridge has a narrow stem extension of the interior chamber,
- 5 (b) an elongated wick which extends from the chamber bottom up to the top of the stem extension, and
- (c) integrally structured means adapted for removal of a top portion of the cartridge stem extension to expose an upper section of the wick to the atmosphere;
- 10 (2) a plug-in heater module; and
- (3) a support frame which is adapted to support the disposable cartridge, wherein the support frame is detachably secured to the heater module, and the support frame maintains the supported cartridge in a vertical position with the cartridge stem extension proximate to the heater
- 15 module for promotion of air freshener wicking into the atmosphere.

11. An air freshener dispenser device in accordance with claim 10 wherein the heater module is a molded plastic plug with a front heating section which contains an embedded electrical-resistance heating element, and with a pair of prongs extending

20 rearwardly from the plug for engagement with a wall electrical outlet, and said prongs are adapted to conduct electric current to the electrical-resistance heating element.

12. An air freshener dispenser device in accordance with claim 11 wherein the plastic plug electrical-resistance heating element is in the form of a film coating or printed

25 pattern on the front heating surface of the plug.

-12-

13. An air freshener dispenser device in accordance with claim 10 wherein the support frame is detachably and rotatably secured to the heater module, so that the support frame and supported-disposable cartridge are adjustable to a vertical position for any orientation of wall electrical outlet.

5

14. A disposable cartridge which is adapted for utility as a module in a heat-activated air freshener dispersion device, wherein the cartridge structure comprises

- (a) an elongated thermoplastic hollow body configuration with a sealed internal reservoir chamber of liquid air freshener medium, and the upper end of the cartridge has a narrow stem extension of the internal chamber;
- (b) an elongated wick which extends from the chamber bottom up to the top of the stem extension; and
- (c) integrally structured means adapted for removal of a top portion of the cartridge stem extension to expose an upper section of the wick to the atmosphere.

10

15

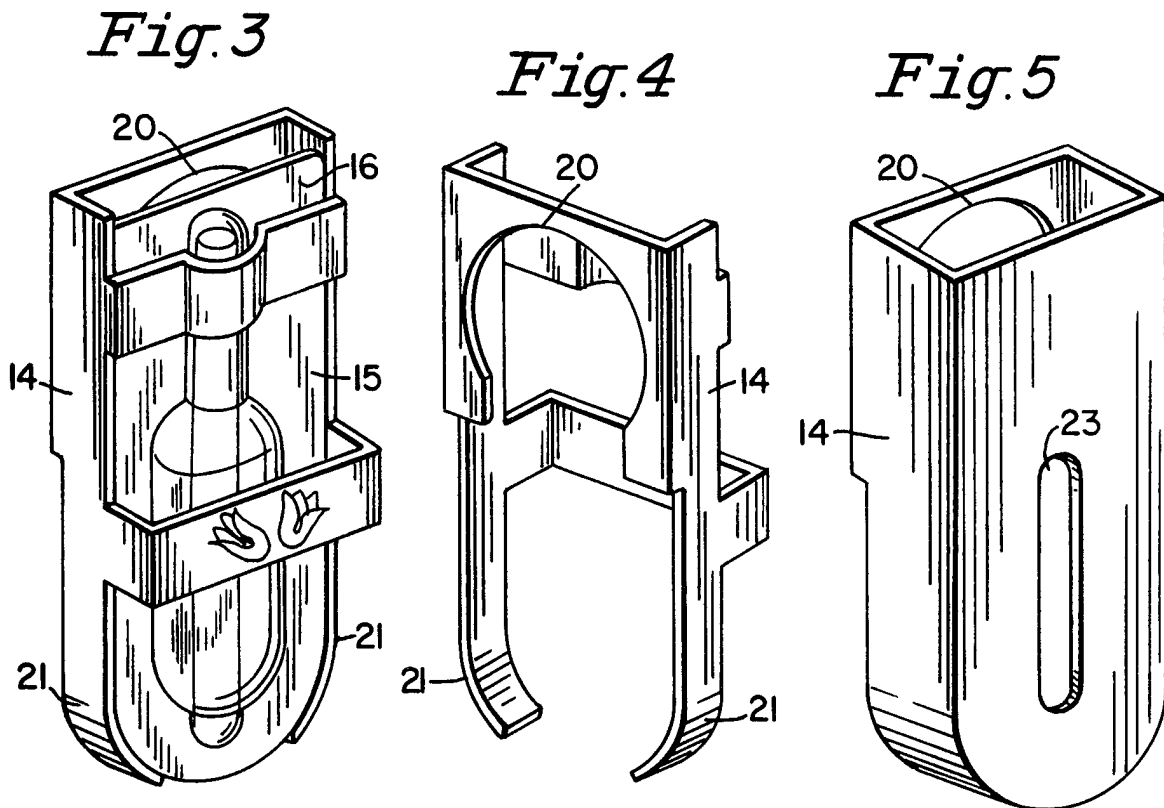
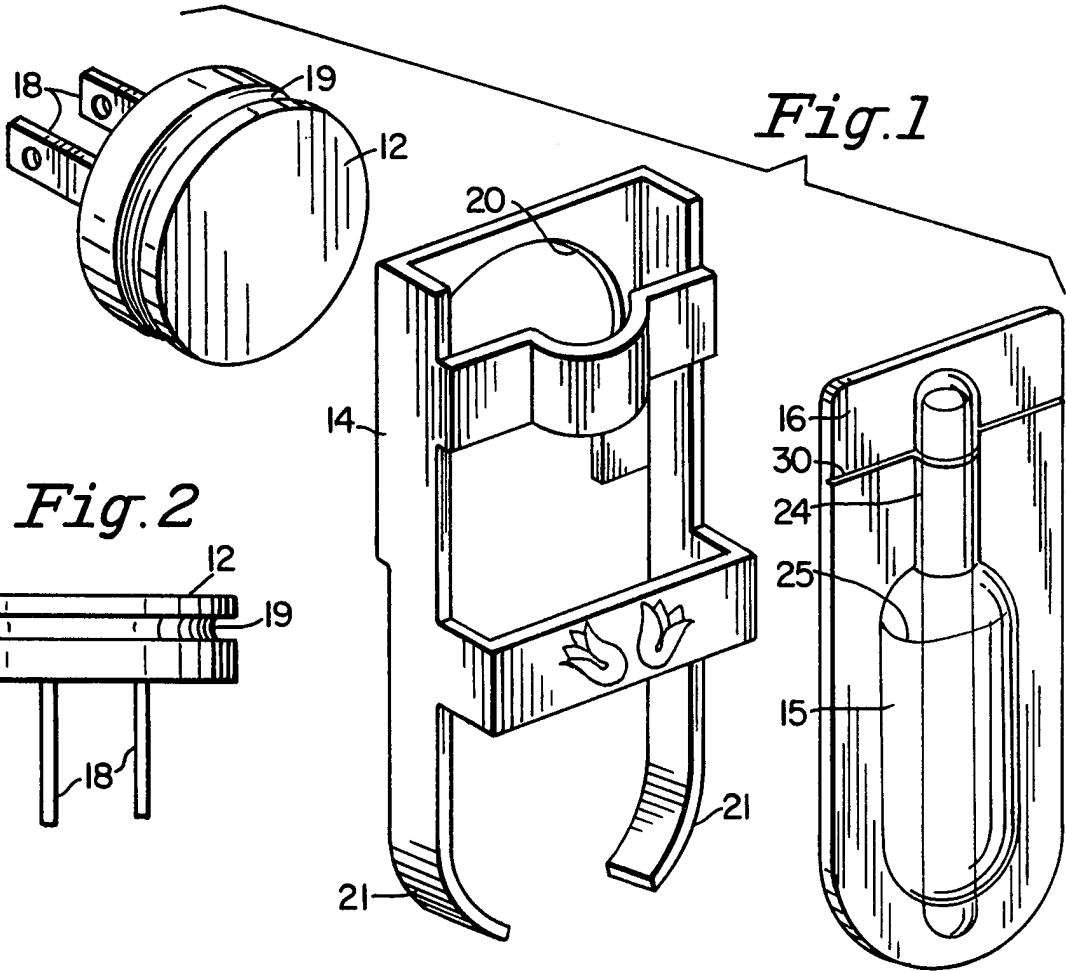

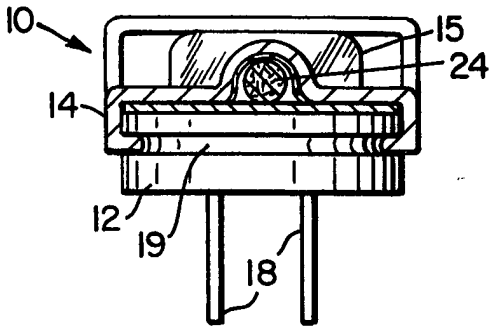

Fig. 7

2 / 2

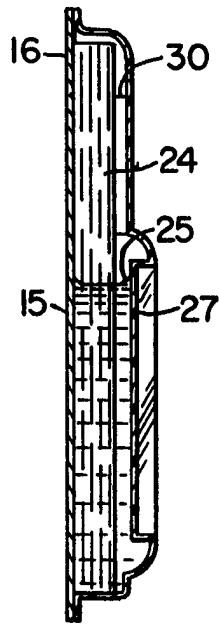

Fig. 8

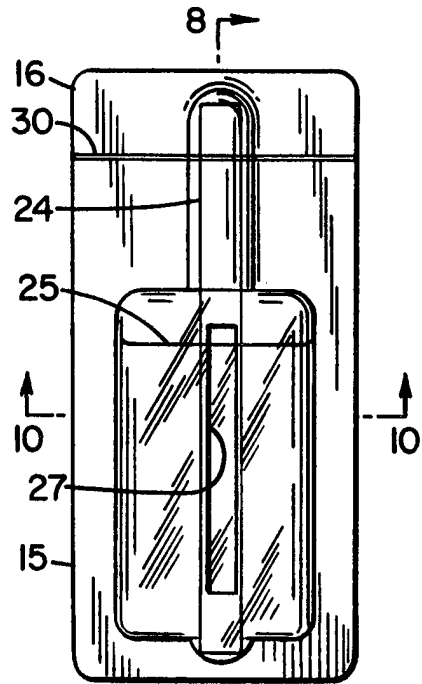

Fig. 9

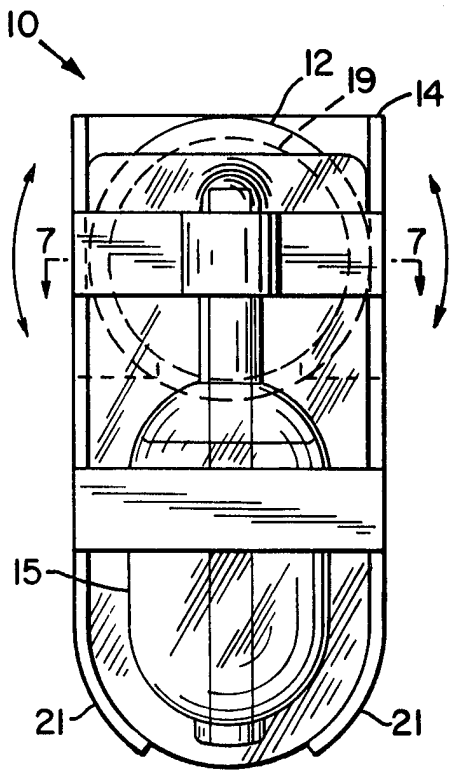

Fig. 6

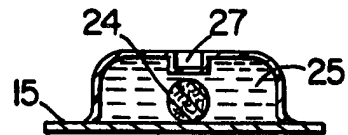
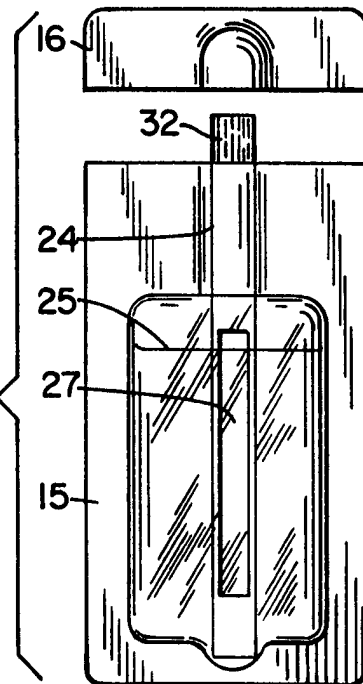

Fig. 10

Fig. 11



INTERNATIONAL SEARCH REPORT

International Application No

PCT/US 98/07737

A. CLASSIFICATION OF SUBJECT MATTER

IPC 6 A61L9/03

According to International Patent Classification (IPC) or to both national classification and IPC

B. FIELDS SEARCHED

Minimum documentation searched (classification system followed by classification symbols)

IPC 6 A61L A01M

Documentation searched other than minimum documentation to the extent that such documents are included in the fields searched

Electronic data base consulted during the international search (name of data base and, where practical, search terms used)

C. DOCUMENTS CONSIDERED TO BE RELEVANT

Category °	Citation of document, with indication, where appropriate, of the relevant passages	Relevant to claim No.
Y	DE 44 46 413 A (GLOBOL GMBH) 27 June 1996 see claims; figures 1-6 ---	1-14
Y	DE 41 31 613 A (GLOBOL GMBH) 25 March 1993 see claims; figures ---	1-14
A	WO 94 15650 A (CULMSTOCK LTD ;PAUL DUNCAN J (GB); MARSH JOHN REES (GB); SMITH NIG) 21 July 1994 see claims; figures ---	1-14
A	DE 36 09 511 A (OREAL) 16 October 1986 see figures ---	1-14
A	GB 2 275 608 A (JOHNSON & SON INC S C) 7 September 1994 see figures 1-9 ---	1-14
	-/--	

Further documents are listed in the continuation of box C.

Patent family members are listed in annex.

° Special categories of cited documents :

- "A" document defining the general state of the art which is not considered to be of particular relevance
- "E" earlier document but published on or after the international filing date
- "L" document which may throw doubts on priority claim(s) or which is cited to establish the publication date of another citation or other special reason (as specified)
- "O" document referring to an oral disclosure, use, exhibition or other means
- "P" document published prior to the international filing date but later than the priority date claimed

- "T" later document published after the international filing date or priority date and not in conflict with the application but cited to understand the principle or theory underlying the invention
- "X" document of particular relevance; the claimed invention cannot be considered novel or cannot be considered to involve an inventive step when the document is taken alone
- "Y" document of particular relevance; the claimed invention cannot be considered to involve an inventive step when the document is combined with one or more other such documents, such combination being obvious to a person skilled in the art.
- "&" document member of the same patent family

Date of the actual completion of the international search

28 September 1998

Date of mailing of the international search report

05/10/1998

Name and mailing address of the ISA

European Patent Office, P.B. 5818 Patentlaan 2
NL - 2280 HV Rijswijk
Tel. (+31-70) 340-2040, Tx. 31 651 epo nl,
Fax: (+31-70) 340-3016

Authorized officer

ESPINOSA, M

INTERNATIONAL SEARCH REPORT

International Application No

PCT/US 98/07737

C.(Continuation) DOCUMENTS CONSIDERED TO BE RELEVANT

Category	Citation of document, with indication, where appropriate, of the relevant passages	Relevant to claim No.
A	FR 2 432 837 A (GLOBOL WERK) 7 March 1980 -----	
A	US 5 556 192 A (WANG SHIH-LIN) 17 September 1996 -----	
A	EP 0 689 766 A (FALP SRL) 3 January 1996 -----	

INTERNATIONAL SEARCH REPORT

Information on patent family members

International Application No

PCT/US 98/07737

Patent document cited in search report	Publication date	Patent family member(s)	Publication date
DE 4446413 A	27-06-1996	AU 695612 B	20-08-1998
		AU 4020095 A	04-07-1996
		BR 9505736 A	23-12-1997
		CN 1133257 A	16-10-1996
		EP 0722742 A	24-07-1996
		JP 8244842 A	24-09-1996
		ZA 9510121 A	06-06-1996

DE 4131613 A	25-03-1993	NONE	

WO 9415650 A	21-07-1994	AU 5837394 A	15-08-1994

DE 3609511 A	16-10-1986	FR 2581878 A	21-11-1986
		AT 391270 B	10-09-1990
		AT 73786 A	15-03-1990
		BE 904443 A	19-09-1986

GB 2275608 A	07-09-1994	NONE	

FR 2432837 A	07-03-1980	DE 7823826 U	08-02-1979
		DK 333379 A	11-02-1980
		NL 7906097 A	12-02-1980
		SE 7906454 A	11-02-1980

US 5556192 A	17-09-1996	NONE	

EP 0689766 A	03-01-1996	NONE	
