

(12) **UK Patent Application** (19) **GB** (11) **2 282 931** (13) **A**

(43) Date of A Publication **19.04.1995**

(21) Application No **9321410.4**

(22) Date of Filing **16.10.1993**

(71) Applicant(s)
United Kingdom Atomic Energy Authority

(Incorporated in the United Kingdom)

**Harwell Laboratory, DIDCOT, Oxfordshire, OX11 0RA,
United Kingdom**

(72) Inventor(s)
**Leslie Melbourne Barrett
Damien Paul Kevin Hartley**

(74) Agent and/or Address for Service
**Marcus John Lofting
United Kingdom Atomic Energy Authority,
Patents Department, Building 329, Harwell
Laboratory, DIDCOT, Oxfordshire, OX11 0RA,
United Kingdom**

(51) INT CL⁶
H04R 17/00

(52) UK CL (Edition N)
**H4J JCE J31J
G1G GPCX G9S**

(56) Documents Cited
**GB 2086582 A EP 0528279 A1 EP 0165886 A2
US 4701659 A US4376302 A US 4322877 A**

(58) Field of Search
**UK CL (Edition M) H4J JCE
INT CL⁵ B06B 1/06 , H04R 17/00**

(54) **Flexible transducer array support**

(57) Electrodes 12 with associated connecting strips 13 are embedded in or on a flexible support 11 of plastics material. The connecting strips 13 couple the electrodes 12 with a plug/socket connector 17. The electrodes 12 are provided with a surface layer of polymeric piezo electric material. The electrode array can be positioned in contact with a surface of any shape and ultrasonic signals generated by supplying electrical pulses to the electrodes 12.

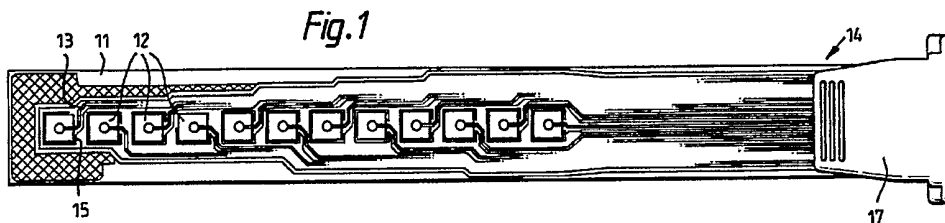

GB 2 282 931 A

Fig. 1

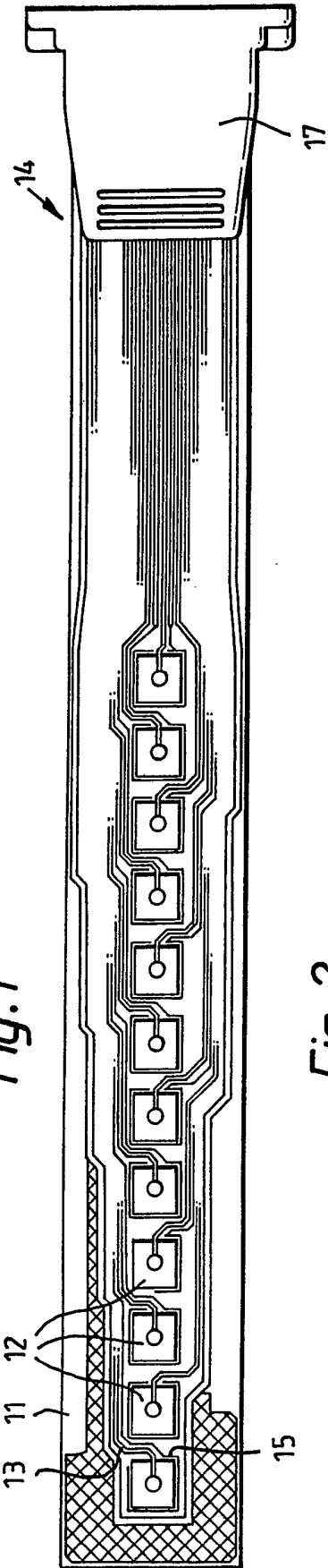

Fig. 2

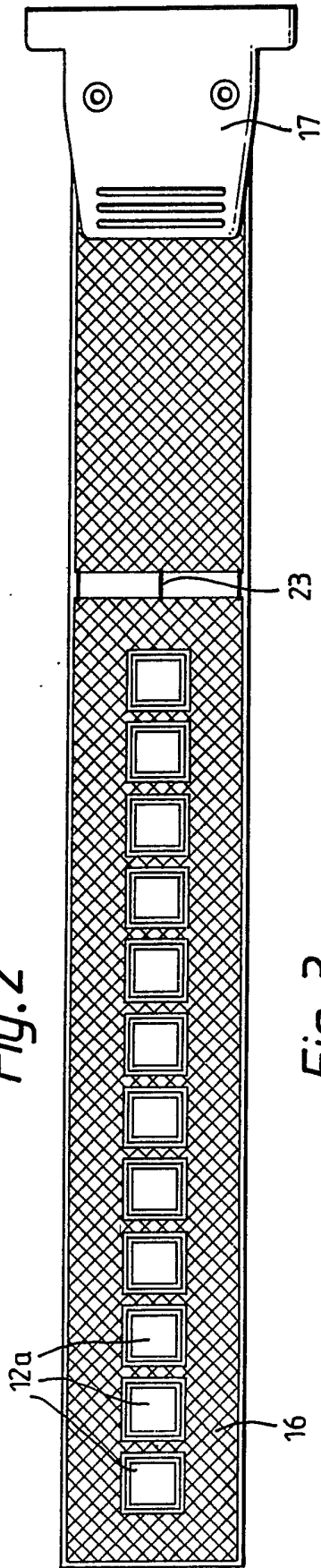

Fig. 3

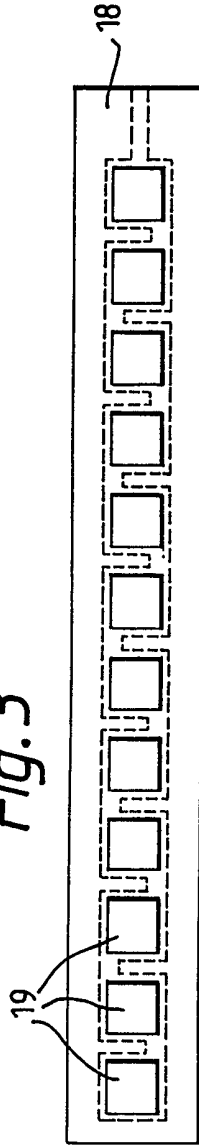

Fig. 4

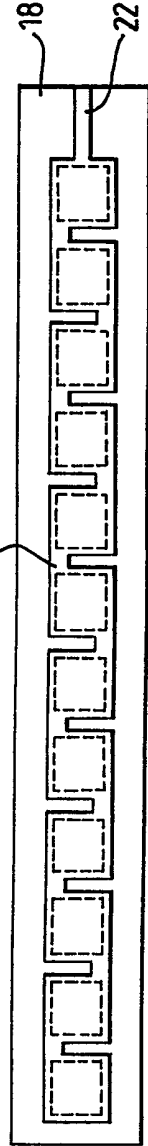

Fig. 5

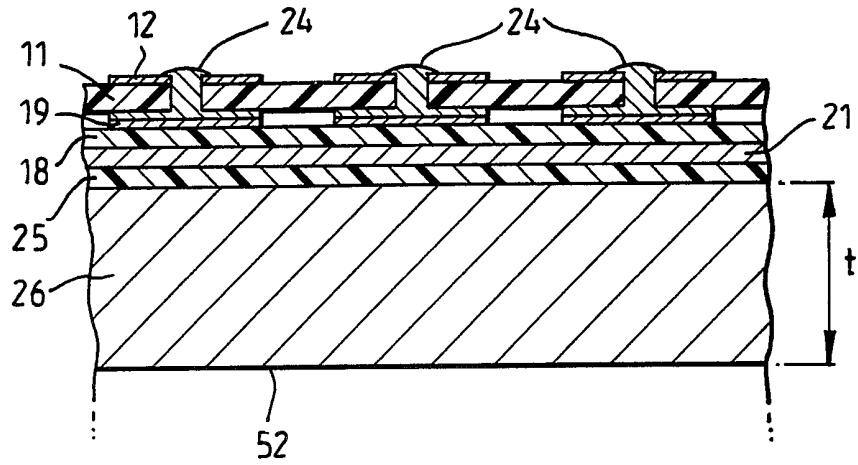

Fig. 6

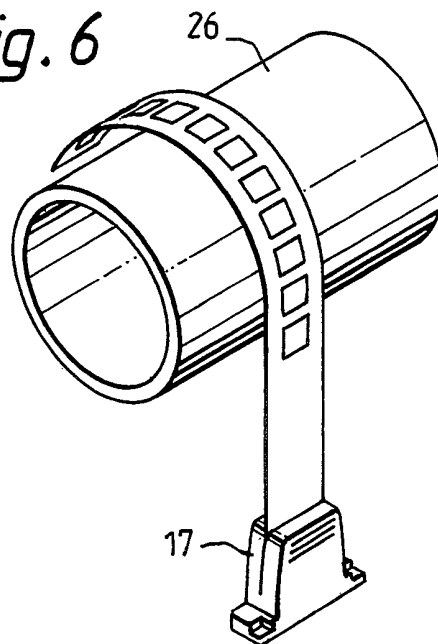

Fig. 7

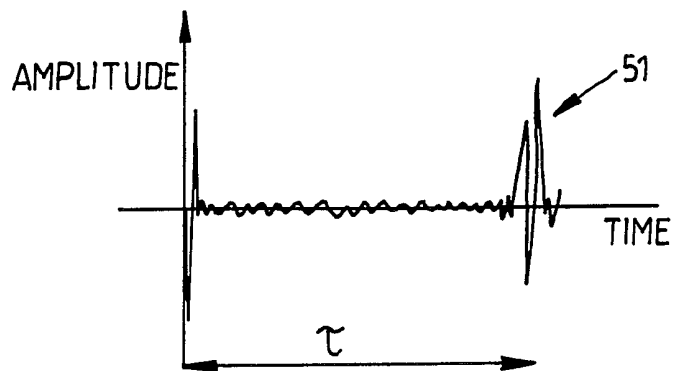

Fig. 8

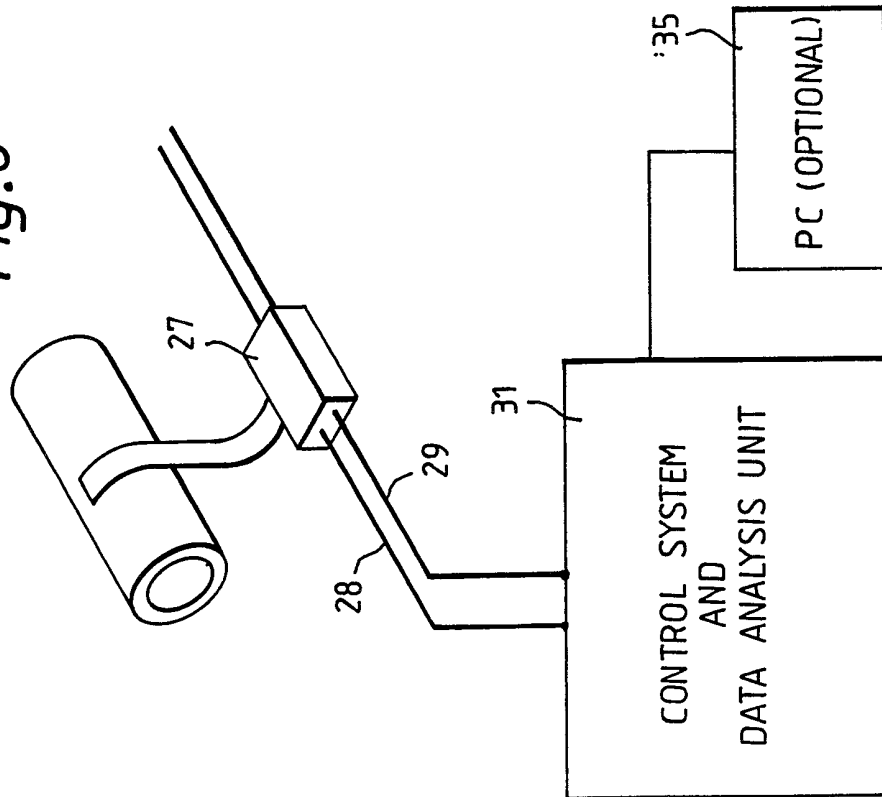

Fig. 9

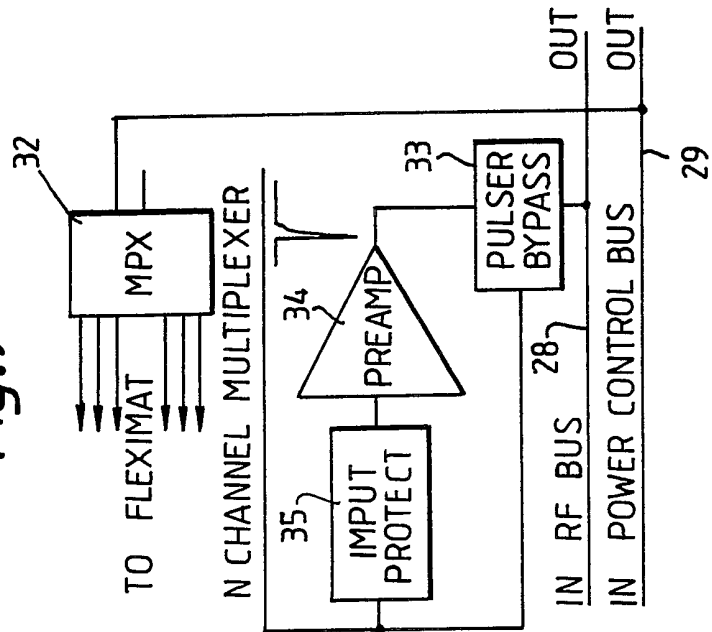
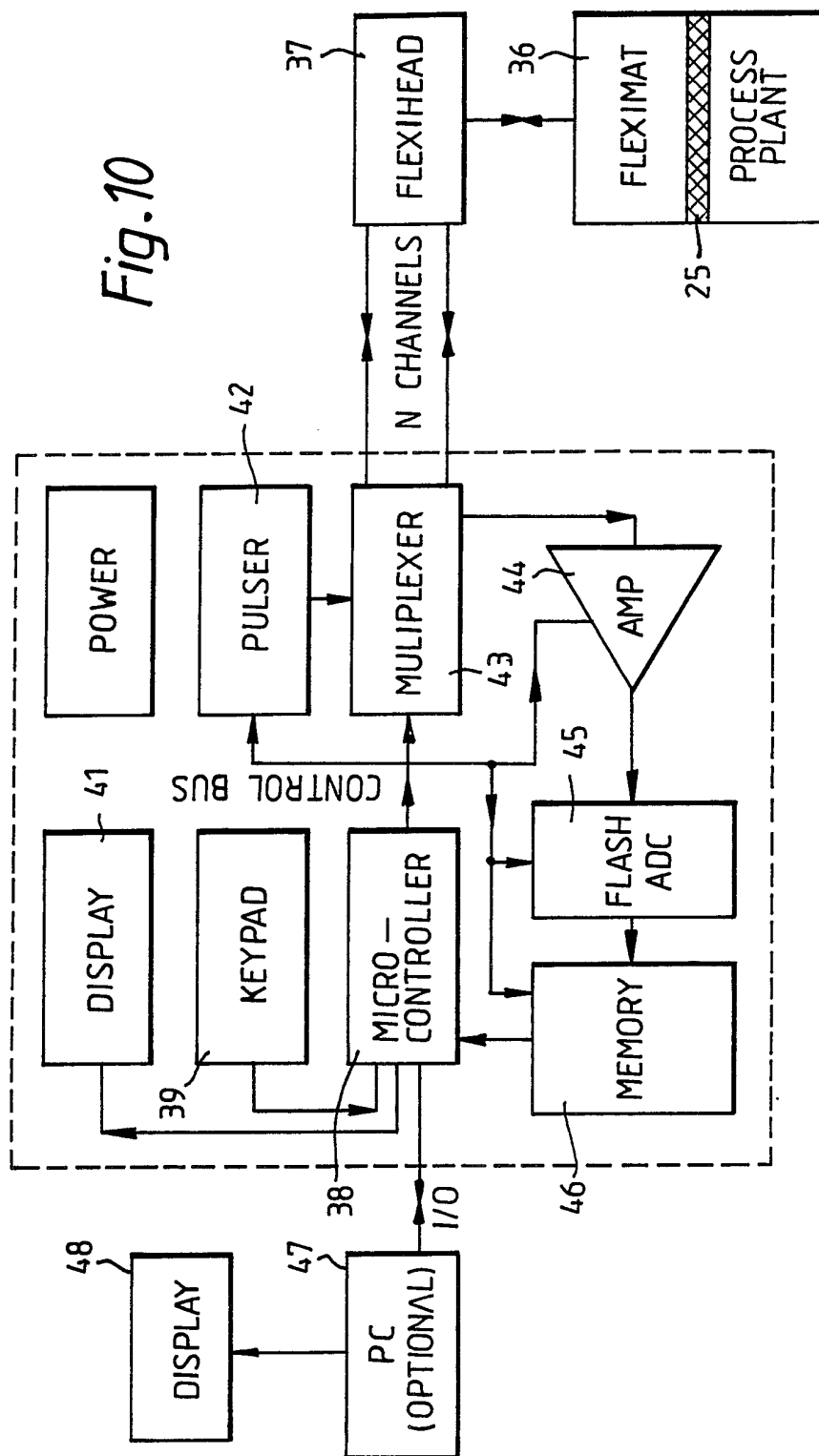

Fig. 10



Flexible Transducer Array Support

The invention relates to a method of testing and a component for use in testing using an array of
5 transducers such as for providing ultrasonic signals.

It is well known to carry out in-service tests of components such as metal pressure vessels and pipelines by positioning an ultrasonic transducer on the available
10 surfaces and recording the echo signal responses when the test object is energised, typically by the injection of a brief transmission pulse of ultrasonic energy. There are other forms of testing which require application of a transducer to the exposed surface of the object under
15 test such as, for example, for eddy current testing.

Positioning of the transducer and ensuring there is good coupling requires the attention of skilled operators. If, as is usual, a large area of object has
20 to be tested, the transducer probe may have to be moved around and the results interpreted. Use of an array of transducers can enable a larger area to be tested at one position of a probe, but the problem of having to move the probe and maintain good coupling remains, since the
25 size of the array will be limited by the variations in surface contour of the components which are to be tested. It is also particularly desirable for in-service tests to compare results at a specific location from tests carried out at regular time intervals which may be months or
30 years apart.

It is an object of the present invention to provide a component and method which facilitates testing of this
35 type.

The invention provides, in one of its aspects, a

component for use in testing comprising a flexible support of plastics material carrying a plurality of electrodes together with connecting strips fixed in or on the said plastics material for providing electrical coupling between the electrodes and a connection region of the flexible plastics material.

Preferably the flexible support of plastics material is in the form of a thin sheet having little or no bending resilience so that the sheet conforms readily to the shape of any object to which it is applied.

Preferably each electrode is at least partly covered by a thin layer of polymeric piezo electric material.

In a preferred construction of component the said flexible support of plastics material carrying electrodes and connecting strips thereon and the piezo electric material are in the form of thin sheets adhered together. Preferably the thin sheet of piezo electric material is coated on both sides with a pattern of thin electrically conducting material arranged in isolated regions on one side positioned to be in electrical contact making abutment with the said electrodes on the flexible support, and in matching electrically interconnected regions on the other side to provide a common electrode, whereby localised ultrasonic pulses can be generated by electrical voltage drive pulses applied to a selected said isolated region relative to the said common electrode region via the respective connecting strip and electrode on the flexible support.

Alternatively, each electrode on the flexible support is separately covered with a thin piece of piezo electric material. However, in this case, provision has to be made for a return or common electrode connection to

the side of the piezo electric material remote from the electrode on the flexible support to which it is attached.

5 Connection of electrical driver and detection
circuitry to the component is facilitated by providing a
standard in-line plug or socket connector clamped to the
connection region of the flexible support so as to make
electrical connection between selected connecting strips
10 on the flexible support and corresponding selected pins
or sockets of the connector.

 The component, with its configuration, simplicity
and relative cheapness of manufacture, lends itself to a
15 method of use which involves more or less permanent
attachment of one or a plurality of such components at
strategically chosen positions in process plant where it
is desired to maintain regular checks on the condition of
the plant.

20
 Commercially available driver/receiver electronics
for ultrasonic flaw detection can be coupled, during a
test run, in turn to each of the components via the plug
or socket connector using a switchbox or custom designed
25 electronics. Time of flight data for ultrasonic pulses
can be established and recorded at each location defined
by each electrode on the flexible supports of each
component. The recorded data from inspections carried
out at routine intervals can be monitored for changes in
30 the time of flight data indicative of corrosion or other
damage to the structure under inspection. Using
components in accordance with the invention fixed
permanently in position, one can be confident that
precisely the same array of test positions is used each
35 time the inspection is carried out.

The invention includes a method of testing comprising applying to an object a thin layer in one or more pieces of flexible piezo electric material having superimposed thereupon a layer of flexible support comprising plastics material carrying a matrix of electrodes in an array together with connecting strips fixed in or on the said plastics material for providing electrical coupling between the electrodes and a connection region of the flexible plastics material, so that the electrodes and the regions of piezo electric material contacted thereby form an array of ultrasonic transducers, connecting the electrodes via the said connection region to a corresponding connector output of a voltage pulse driver/receiver, and operating the driver/receiver so as to transmit and/or receive ultrasonic signals in the object via one or more transducers in the array.

A specific construction of component and a method embodying the invention will now be described by way of example and with reference to the drawings filed herewith in which:

Figure 1 is a plan view of a component,

Figure 2 is a view from below of the component shown in Figure 1 with a part removed,

Figure 3 is a plan view of this removed part, which is a thin strip of polymeric piezo electric material,

Figure 4 is a view from below of the part shown in Figure 3,

Figure 5 is an enlarged sectional view partly cut away of a component in position on a pipeline,

Figure 6 is a diagrammatic perspective view to illustrate a component and a pipeline to which it is to be attached,

5 Figure 7 is a plot of ultrasonic pulse amplitude against time to illustrate the typical signal pulse and echo sequence obtained in use of the component,

10 Figure 8 is a highly diagrammatic representation of an electrical circuit control system and data analysis unit and the method of connection to one or more components of the type shown in Figures 1 to 6 which we have given the name "fleximat",

15 Figure 9 is an electrical block diagram showing the components of a coupling head for connecting the control system and data analysis unit to the fleximat, and

20 Figure 10 is an electrical block diagram illustrating the essential components of a control system and data analysis unit.

Referring to Figure 1, there is shown a flexible film 11 of Kapton plastics material in which are embedded
25 twelve thin rectangular electrodes 12, the underside surface marked 12a of which is exposed (see Figure 2). Each electrode 12 is electrically connected to a connecting strip 13 embedded in the flexible film 11 and leading to a connection region 14 at an edge of the film
30 11. Running parallel with each connecting strip 13 is a thinner screen strip 15 which extends around the periphery of the associated electrode 12. Further screening is provided by a matrix of thin conducting strips 16 embedded in the film 11 close to the underside.
35 It will be appreciated that the arrangement of the screen strips 15 and screen matrix 16 are such that they are

electrically isolated by the plastics material of the flexible film 11 from the conducting strips 13 and electrodes 12.

5 A standard in line plug or socket connector 17 is clamped to the edge of the flexible film 11 at 14 and provides readily for appropriate electrical connection to the connecting strips 13, screen strips 15 and screen matrix 16.

10

 Figures 3 and 4 show respectively the upper and lower surfaces of a thin film 18 of polymeric (Polyvinylidene fluoride) piezo electric material. Such material is available in a form in which the opposed surfaces are coated with an electrically conducting silver ink. This has been etched to provide on the upper surface a series of rectangular islands 19 which are electrically isolated from one another and positioned to correspond with the exposed surfaces 12a of the electrodes in the flexible film 11. Figure 4 shows the pattern etched into the silver ink on the underside of the piezo electric film 18 so as to provide a common electrode layer 21. It will be appreciated that if an electrical signal voltage pulse is applied to a selected one of the islands 19 relative to the common electrode layer 21, then a corresponding pressure pulse is generated by the piezo electric material in the region of the island 19.

30 The piezo electric film 18 is fixed with adhesive to the underside of the flexible film 11 so that the islands 19 are in contact with the exposed surfaces 12a of the electrodes 12. Connection to the common electrode layer 21 is made by folding under a small region at the end of the piezo electric film 18 so that a portion at 22 of the electrode layer 21 is brought into electrical contact at

35

23 with the screen matrix 16 in the flexible film 11.

Each electrode 12 has a hole extending through the centre from the top to the bottom surface of the flexible film 11. After fixing the piezo electric film 18 to the flexible film 11 with adhesive, these holes are filled with silver ink to provide good electrical contact between the electrodes 12 and the islands 19. This may be seen in Figure 5 in which the silver ink filling the holes through the electrodes 12 is marked at 24.

For use, the component as described with reference to Figures 1 to 5 can be fixed permanently to, for example, a metal pipeline 26 (see also Figure 6). Attachment is conveniently by means of a layer of epoxy resin 25. A plurality of fleximats may be attached at chosen locations on the pipework of an installation so that periodic ultrasonic inspections can routinely be made.

Such inspections may be carried out by an operator carrying an ultrasonic drive/receive unit of a form readily commercially available, and a switchbox to connect in turn to each of the fleximats via the plug/socket connector 17.

However, we prefer to provide an arrangement in which all of the fleximats within an installation or a region of an installation are set up ready coupled via a coupling head 27 (Figure 8) to electrical buses 28 and 29 which provide respectively for radio frequency pulse signals (28) and control and power supply (29). A full inspection run is carried out from a central control system and data analysis unit 31 which is either permanently connected to the buses 28 and 29 or is connected to them at the time of the inspection.

Figure 9 shows in block diagram form the essential electrical components of the coupling head 27. Operation of a multiplexer 32 is controlled by signals on the power and control bus 29. When the coupling head 27 is selected by the appropriate coded signal from the control system, radio frequency pulses are fed via a pulser bypass 33 and distributed via the multiplexer to each electrode 12 in turn on the associated fleximat. The number of channels provided by the multiplexer will correspond to the number of electrodes 12 in the fleximat. In this example, there are twelve such electrodes, but it will be appreciated that any convenient number can be provided. Under control of the multiplexer 32, echo signals received back via each transducer are detected and amplified by pre-amplifier 34 and returned via the RF bus 28 to the central control system 31. An input protection circuit 35 protects the amplifier 34 from drive pulses.

The central control system and data analysis unit 31 essentially consists of a micro controller carrying out all supervisory, set up, data collection, data analysis and input/output functions. The appropriate fleximat is selected and excited via a multiplexer, pulses supplied and the returning echo amplified. The returning echo signal is converted to digital data using a flash analogue to digital converter and the resulting digital data is stored in a local memory for subsequent processing by the micro controller which can be set up to interpret the results and display chosen parameters. Provision for operator interaction/manipulation via an external PC 35 can optionally be readily provided.

Figure 10 illustrates in block diagram form the components of a self contained control system appropriate for use by an operator who would manually connect this in

turn to each fleximat 36 via a coupling head 37. The essential components of micro controller 38, associated key pad 39 and display 41, pulser 42, multiplexer 43, amplifier 44, flash analogue to digital converter 45, memory 46 and optional personal computer 47 with its associated display 48 all correspond closely with those referred to above in describing the essential operation of the arrangement having a central control system and data analysis unit 31.

10

As is well known, a drive ultrasonic pulse of the form shown at time = 0 in Figure 7 when applied at a surface of a component such as the metal pipeline 26 will result in an echo signal 51 reflected from the back surface 52 (see Figure 5) of the component. The delay τ between the drive pulse and echo pulse is indicative of the thickness T of the metal of the pipeline 26. Thus, for example, changes in thickness caused by corrosion will show up over the passage of time. Also, a crack appearing in the metal in the path of an ultrasonic pulse will result in a reflection at some point between the drive pulse and back reflection echo 51 so that information about the appearance of such cracks and their extent can be derived from analysis of the echo signal data.

25

The invention is not restricted to the details of the foregoing example. It will be appreciated that it is possible in principle to provide directly for the excitation of selected regions in sequence of a polymeric piezo electric film by etching conducting films on the surfaces thereof into a pattern corresponding to the pattern of electrodes and conducting strips provided in the foregoing example on the flexible support film 11. However, we have found that such an approach is less satisfactory for a number of reasons. In particular the

30
35

flexible polymeric piezo electric film is not on its own sufficiently robust. Also, the passage of the drive pulse currents through conducting strips on the surface of piezo electric film tends to generate pressure pulses all along the length of the conducting strips. This generates a noise which interferes with the desired information derived from the pressure pulses generated at the island electrodes 19.

10

14967 LgR

Claims

1. A component for use in testing comprising a flexible support of plastics material carrying a plurality of electrodes together with connecting strips fixed in or on the said plastics material for providing electrical coupling between the electrodes and a connection region of the flexible plastics material.
2. A component as claimed in Claim 1, wherein the flexible support of plastics material is in the form of a thin sheet having little or no bending resilience so that the sheet conforms readily to the shape of any object to which it is applied.
3. A component as claimed in Claim 1 or Claim 2, wherein each electrode is at least partly covered by a thin layer of polymeric piezo electric material.
4. A component as claimed in any of Claims 1 to 3, wherein the said flexible support of plastics material carrying electrodes and connecting strips thereon and the piezo electric material are in the form of thin sheets adhered together.
5. A component as claimed in Claim 4, wherein the thin sheet of piezo electric material is coated on both sides with a pattern of thin electrically conducting material arranged in isolated regions on one side positioned to be in electrical contact making abutment with the said electrodes on the flexible support, and in matching but electrically interconnected regions on the other side to provide a common electrode, whereby localised ultrasonic pulses can be generated by electrical voltage drive pulses applied to a selected said isolated region relative to the said common electrode region via the

respective connecting strip and electrode on the flexible support.

5 6. A component as claimed in any one of Claims 1 to 3,
wherein each electrode on the flexible support is
separately covered with a thin piece of piezo electric
material, and a return or common electrode connection is
provided on the side of the piezo electric material
remote from the electrode on the flexible support to
10 which it is attached.

15 7. A component as claimed in any of the preceding
claims, wherein a standard in-line plug or socket
connector is clamped to the connection region of the
flexible support so as to make electrical connection
between selected connecting strips on the flexible
support and corresponding selected pins or sockets of the
connector.

20 8. A method of testing using a component as claimed in
any of the preceding claims, which method comprises the
permanent attachment of one or a plurality of such
components at strategically chosen positions in process
plant where it is desired to maintain regular checks on
25 the condition of the plant.

30 9. A method of testing comprising applying to an object
a thin layer in one or more pieces of flexible piezo
electric material having superimposed thereupon a layer
of flexible support comprising plastics material carrying
a matrix of electrodes in an array together with
connecting strips fixed in or on the said plastics
material for providing electrical coupling between the
electrodes and a connection region of the flexible
35 plastics material, so that the electrodes and the regions
of piezo electric material contacted thereby form an

array of ultrasonic transducers, connecting the
electrodes via the said connection region to a
corresponding connector output of a voltage pulse
driver/receiver, and operating the driver/receiver so as
5 to transmit and/or receive ultrasonic signals in the
object via one or more transducers in the array.

10. A component substantially as herein described with
reference to, and illustrated in, Figures 1 to 6 of the
10 drawings filed herewith.

11. A method of testing substantially as herein
described with reference to Figures 6 to 10 of the
drawings filed herewith.

15

20

Relevant Technical Fields

- (i) UK Cl (Ed.M) H4J (JCE)
 (ii) Int Cl (Ed.5) H04R 17/00; B06B 1/06

Search Examiner
 P J EASTERFIELD

Date of completion of Search
 4 JANUARY 1994

Databases (see below)

- (i) UK Patent Office collections of GB, EP, WO and US patent specifications.
 (ii)

Documents considered relevant following a search in respect of Claims :-
 1-9

Categories of documents

- X:** Document indicating lack of novelty or of inventive step. **P:** Document published on or after the declared priority date but before the filing date of the present application.
Y: Document indicating lack of inventive step if combined with one or more other documents of the same category. **E:** Patent document published on or after, but with priority date earlier than, the filing date of the present application.
A: Document indicating technological background and/or state of the art. **&:** Member of the same patent family; corresponding document.

Category	Identity of document and relevant passages	Relevant to claim(s)
X	GB 2086582 A (LIST)	1-5, 8
X	EP 0528279 A1 (KUREHA)	1-5, 8
X	EP 0165886 A2 (NGK)	1-5, 8
X	US 4701659 A (FUJII ET AL)	1-5, 8
X	US 4376302 A (MILLER)	1-5, 8
X	US 4322877 A (TAYLOR)	1-5, 8

Databases:The UK Patent Office database comprises classified collections of GB, EP, WO and US patent specifications as outlined periodically in the Official Journal (Patents). The on-line databases considered for search are also listed periodically in the Official Journal (Patents).