

AUSTRALIA  
PATENTS ACT 1990  
NOTICE OF ENTITLEMENT

I, **Urs A. Ramel**, the applicant/Nominated Person in respect of Application No. 30633/92 state the following:-

The Nominated Person is entitled to the grant of the patent because the Nominated Person is the inventor.

The Nominated Person is entitled to claim priority from the application listed in the declaration under Article 8 of the PCT because the Nominated Person made the application listed in the declaration under Article 8 of the PCT, and because that application was the first application made in a Convention country in respect of the invention.

DATED this TWENTY SIXTH day of MAY 1994



.....  
a member of the firm of  
DAVIES COLLISON  
CAVE for and on behalf  
of the applicant(s)

(DCC ref: 1666120)



PAPCB13B 1.9

PCT APPLICATION DETAILS

17/05/94 10:03:08 9

Application ID: 30633 / 92 PCT Number : PCT/US92/09456  
Applicant-Name

SECTION 113 DIRECTION SEE FOLIO a

NAME DIRECTED Actimed Laboratories, Inc of  
5 Terri Lane, Burlington, New Jersey  
08016, United states of America.



Priority Country Priority Date Priority App. No.  
US 12 NOV 91 790376

Address-for Service :

DAVIES COLLISON CAVE

1 Little Collins Street

MELBOURNE VIC 3000

Date of Lodgement : 12 NOV 92

668533



AU9230633

**(12) PATENT ABRIDGMENT (11) Document No. AU-B-30633/92**  
**(19) AUSTRALIAN PATENT OFFICE (10) Acceptance No. 668533**

- (54) Title  
**LANCET DEVICE**
- International Patent Classification(s)  
(51)<sup>5</sup> **A61B 005/14**
- (21) Application No. : **30633/92** (22) Application Date : **12.11.92**
- (87) PCT Publication Number : **WO93/09723**
- (30) Priority Data
- (31) Number (32) Date (33) Country  
**790376 12.11.91 US UNITED STATES OF AMERICA**
- (43) Publication Date : **15.06.93**
- (44) Publication Date of Accepted Application : **09.05.96**
- (71) Applicant(s)  
**ACTIMED LABORATORIES, INC.**
- (72) Inventor(s)  
**URS A. RAMEL**
- (74) Attorney or Agent  
**DAVIES COLLISON CAVE , 1 Little Collins Street, MELBOURNE VIC 3000**
- (56) Prior Art Documents  
**AU 657537 17944/92 A61B 17/32**  
**US 5026388**  
**US 4416279**
- (57) Claim

1. A lancet device having an armed state from which it can be released to pierce human or animal tissue, the device comprising:

a lance, including a needle and a shaft with one or more arms; a spring, one end of which is fixedly attached to said shaft of said lance; a base, including a well wherein said lance and spring are located; means for fixedly attaching the other end of said spring to said base;

a trigger, including a barrel to slidably accept said lance and having one or more slots to slidably engage said one or more arms of said lance when said device is released from the armed state, means for retaining said lance and spring in a compressed armed position prior to use, an end with an orifice to allow said needle to protrude through said orifice when said lance and spring are released from said armed position to pierce human or other animal tissue, and rotational means for rotating said trigger about its central longitudinal axis to rotatably align each said slot with one of said arms such that said arms are slidably engaged in said

(11) AU-B-30633/92  
(10) 668533

-2-

slots thereby releasing said lance and said spring from said armed position during use;

means for controlling the depth of penetration of said needle into said tissue;

a body, including a barrel having an outer surface and a hollow center to slidably accept said trigger and fixedly accept said base, an open end distal from said base, said open end being in about the same plane as the face of said orifice-containing end of said trigger when said trigger is inserted into said body, and means for retaining said trigger in said barrel:

means for fixedly attaching said base to said body;

means for aligning said orifice-containing end of said trigger in about the same plane as said open end of said body; and

means for centering and guiding said trigger rotatably in said body about the central longitudinal axis of said body, said central longitudinal axis of said body identical to said central longitudinal axis of said trigger.

13. A lancet device, comprising:

a lance, including a needle of a specific length and a shaft with one or more arms;

a spring, one end of which is fixedly attached to said shaft of said lance;

a trigger, including a barrel with an outer surface, one or more slots and a hollow center to slidably accept said lance, an end having a specific wall thickness and an orifice, an end distal from said orifice-containing end to engage said arms of said lance to compress said spring, and one or more pins on said outer surface;

a body, including a barrel, a hollow center to slidably accept said trigger, a base with a well wherein said lance and spring are located in a compressed armed position prior to use, one or more angled slots in said barrel for engaging said pins of said trigger, and an end distal from said base being in about the same plane as the face of said orifice-containing end of said trigger when said pins of said trigger are engaged in said slots of said body;

(11) AU-B-30633/92

-3-

(10) 668533

means for fixedly attaching the other end of said spring to said base;

one or more slots in said base to slidably accept said arms of said lance;

said distal end of said trigger retaining said lance and spring in said compressed armed position in said well when said pins in said trigger are engaged in the top of said angled slots of said body; and

said angled slots of said body guiding said pins of said trigger to rotate said trigger when said trigger is depressed so that said slots of said trigger align with said slots of said base and said arms of said lance to release said lance and spring to allow said needle to protrude through said orifice to pierce human or other animal tissue.

OPI DATE 15/06/93 APPLN. ID 30633/92  
 AOJP DATE 19/08/93 PCT NUMBER PCT/US92/09456



AU9230633

INTERNATIONAL PATENT COOPERATION TREATY (PCT)

<p>(51) International Patent Classification <sup>5</sup> : <b>A61B 17/32</b></p>	<p><b>A1</b></p>	<p>(11) International Publication Number: <b>WO 93/09723</b>          (43) International Publication Date: 27 May 1993 (27.05.93)</p>
<p>(21) International Application Number: PCT/US92/09456          (22) International Filing Date: 12 November 1992 (12.11.92)          (30) Priority data:          790,376 12 November 1991 (12.11.91) US  <del>(71)(72) Applicant and Inventor: RAMEL, Urs., A. [US/US];          1331 Los Arboles Avenue, Sunnyvale, CA 94087 (US).</del>          (74) Agents: BALDWIN, Stephen, E. et al.; Heller, Ehrman,          White &amp; McAuliffe, 333 Bush Street, San Francisco, CA          94104-2878 (US).          (A) Actimed Laboratories, Inc          of 5 Terni Lane, Burlington          New Jersey, 08016 U.S.A.</p> 		<p>(81) Designated States: AU, CA, JP, KR, European patent (AT, BE, CH, DE, DK, ES, FR, GB, GR, IE, IT, LU, MC, NL, SE).          Published          With international search report.</p> <p style="font-size: 2em; text-align: center;">668533</p>

(54) Title: LANCET DEVICE

(57) Abstract

A lancet device includes a body (242) within which is slidably located a trigger (224) and fixedly located a base (214). The base (214) contains, in an armed position, the lance (202) with its needle (204) and a spring affixed to the lance. The trigger includes means to release the lance during use. In preferred embodiment, the lancet device of the present invention is self-activated by the finger (or other body part) to be pierced. Depression of the trigger with the finger releases the lance and the spring so that the needle protrudes through an orifice in the end of the trigger and pierces the tissues. Because the spring is held in a pre-armed position, release of the spring is consistent, and reproducibility of incision is well controlled.

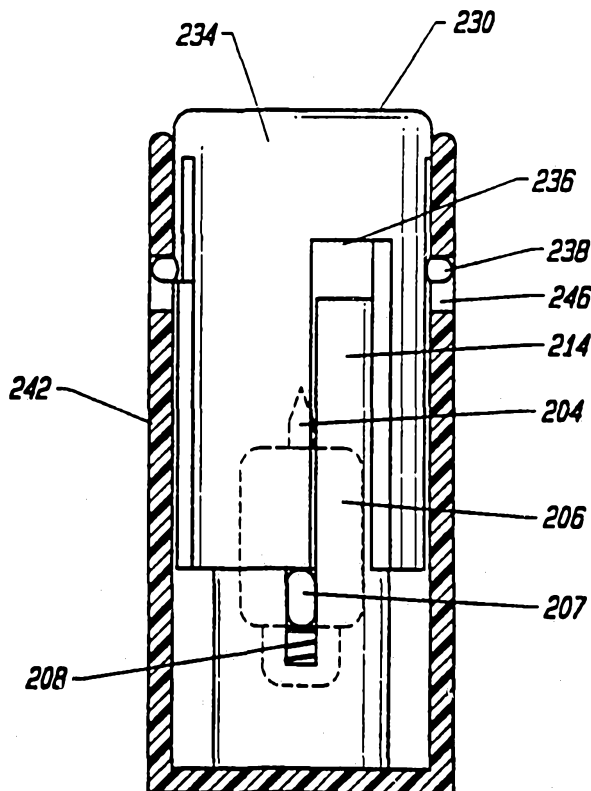

-1-

**LANCET DEVICE****BACKGROUND OF THE INVENTION**

This invention relates to a lancet device for use in taking capillary blood samples by pricking a body tissue, such as a fingertip.

5           In the case of certain diseases, such as diabetes, or test kits, such as cholesterol test kits, a patient is required to provide small specimens of blood for analysis. This involves pricking a finger or other suitable body part in  
10 order to obtain the blood specimen. It is physiologically and psychologically difficult for many people to prick their own finger with a hand-held needle, which must be sterile.

15           Other lancet devices for obtaining blood samples, such as are disclosed in U.S. Patent Nos.

4,869,249 and 4,817,603, include a cap which is used to protect the needle or to keep the needle sterile. This makes manufacturing of these devices more difficult and costly, and makes the device harder to use.

5 In other devices, a spring used to shoot a needle into the tissue is compressed during use by the trigger mechanism, which can lead to misfiring or skewing of the spring so that the incision made is not suitable for obtaining a blood sample. Also, two hands are required for operation of many  
10 of these devices.

Thus, there is a need for a simple, inexpensive, reliable, self-activating, disposable lancet device in which reproducibility of suitable incisions is well controlled.

15 SUMMARY OF THE INVENTION

It is an object of the present invention to provide an improved lancet device.

According to the present invention, there is provided a lancet device having an armed state from which it can be  
20 released to pierce human or animal tissue, the device comprising:

a lance, including a needle and a shaft with one or more arms; a spring, one end of which is fixedly attached to said shaft of said lance; a base, including a well wherein said  
25 lance and spring are located; means for fixedly attaching the other end of said spring to said base;

a trigger, including a barrel to slidably accept said lance and having one or more slots to slidably engage said one or more arms of said lance when said device is released  
30 from the armed state, means for retaining said lance and spring in a compressed armed position prior to use, an end with an orifice to allow said needle to protrude through said orifice when said lance and spring are released from said armed position to pierce human or other animal tissue, and  
35 rotational means for rotating said trigger about its central longitudinal axis to rotatably align each said slot with one of said arms such that said arms are slidably engaged in said





slots thereby releasing said lance and said spring from said armed position during use;

means for controlling the depth of penetration of said needle into said tissue;

5 a body, including a barrel having an outer surface and a hollow center to slidably accept said trigger and fixedly accept said base, an open end distal from said base, said open end being in about the same plane as the face of said orifice-containing end of said trigger when said trigger is  
10 inserted into said body, and means for retaining said trigger in said barrel:

means for fixedly attaching said base to said body;

means for aligning said orifice-containing end of said trigger in about the same plane as said open end of said  
15 body; and

means for centering and guiding said trigger rotatably in said body about the central longitudinal axis of said body, said central longitudinal axis of said body identical to said central longitudinal axis of said trigger.

20 The present invention also provides a lancet device, comprising:

a lance, including a needle of a specific length and a shaft with one or more arms;

25 a spring, one end of which is fixedly attached to said shaft of said lance;

a trigger, including a barrel with an outer surface, one or more slots and a hollow center to slidably accept said lance, an end having a specific wall thickness and an orifice, an end distal from said orifice-containing end to  
30 engage said arms of said lance to compress said spring, and one or more pins on said outer surface;

a body, including a barrel, a hollow center to slidably accept said trigger, a base with a well wherein said lance and spring are located in a compressed armed position prior  
35 to use, one or more angled slots in said barrel for engaging said pins of said trigger, and an end distal from said base being in about the same plane as the face of said



orifice-containing end of said trigger when said pins of said trigger are engaged in said slots of said body; means for fixedly attaching the other end of said spring to said base;

5 one or more slots in said base to slidably accept said arms of said lance;

said distal end of said trigger retaining said lance and spring in said compressed armed position in said well when said pins in said trigger are engaged in the top of said angled slots of said body; and

10 said angled slots of said body guiding said pins of said trigger to rotate said trigger when said trigger is depressed so that said slots of said trigger align with said slots of said base and said arms of said lance to release said lance and spring to allow said needle to protrude through said orifice to pierce human or other animal tissue.

15 There is also provided, in accordance with the invention, a lancet device having an armed state from which it can be released to pierce human or animal tissue, the device comprising:

20 a lance, including a needle and a shaft with one or more arms;

a base, including a well wherein said lance is located, said well having a bottom;

25 a spring, located in said well between said shaft of said lance and said bottom of said well;

a trigger, including a barrel to slidably accept said lance and having one or more slots to slidably engage said one or more arms of said lance when said device is released from the armed state, means for retaining said lance and spring in a compressed armed position prior to use, an end with an orifice to allow said needle to protrude through said orifice when said lance and spring are released from said armed position to pierce human or other animal tissue, and rotational means for rotating said trigger about its central longitudinal axis to rotatably align each said slot with one of said arms such that said arms are slidably engaged in said

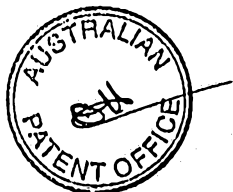

slots thereby releasing said lance and spring from said armed position during use;

means for controlling the depth of penetration of said needle into said tissue;

5 a body, including a barrel to slidably accept said trigger and fixedly accept said base, an open end distal from said base, said open end being in about the same plane as the face of said orifice-containing end of said trigger when said trigger is inserted into said body, and means for retaining  
10 said trigger in said barrel;

means for fixedly attaching said base to said body;

means for aligning said orifice-containing end of said trigger in about the same plane as said open end of said body; and

15 means for centering and guiding said trigger rotatably in said body about the central longitudinal axis of said body, said central longitudinal axis of said body identical to said central longitudinal axis of said trigger.

The invention also provides a lancet device, comprising:

20 a lance, including a needle and a shaft with one or more arms;

a base, including a well wherein said lance is located, said well having a bottom;

25 a spring, located in said well between said shaft of said lance and said bottom of said well;

means for retaining said lance and spring in a compressed armed position prior to use;

30 a trigger, including a barrel with an outer surface, one or more longitudinal slots and a hollow center to slidably accept said lance, an end having an orifice, and one or more pins on said outer surface;

35 a body, including a barrel to slidably accept said trigger and fixedly accept said base, one or more angled slots in said barrel for engaging said one or more pins on said outer surface of said trigger, and an end distal from said base being in about the same plane as the face of said orifice-containing end of said trigger when said one or more



pins of said trigger are engaged in said one or more angled slots of said body; and

said one or more angled slots of said body guiding said one or more pins of said trigger to rotate said trigger about  
5 the central longitudinal axis of said body when said trigger is depressed so that said one or more longitudinal slots of said trigger align with said one or more arms of said lance, releasing said lance and spring to allow said needle to protrude through said orifice to pierce human or other animal  
10 tissue.

The invention further provides a lancet device, comprising:

a lance, including a needle and a shaft;

a spring, one end of which is fixedly attached to said  
15 shaft of said lance;

a base, including a well wherein said lance and spring are located;

means for fixedly attaching the other end of said spring to said base;

20 a trigger, including a barrel to slidably accept said lance, means for retaining said lance and spring in a compressed armed position prior to use, an end with an orifice to allow said needle to protrude through said orifice when said lance and spring are released from said armed  
25 position to pierce human or other animal tissue, and rotational means for rotating said trigger about its central longitudinal axis to rotatably release said lance and said spring from said armed position during use;

30 means for controlling the depth of penetration of said needle into said tissue;

a body, including a barrel having an outer surface and a hollow center to slidably accept said trigger and fixedly accept said base, an open end distal from said base, said open end being in about the same plane as the face of said  
35 orifice-containing end of said trigger when said trigger is inserted into said body, and means for retaining said trigger in said barrel;



means for fixedly attaching said base to said body;  
said rotational means for rotating said trigger about  
its central longitudinal axis to rotatably release said lance  
and spring comprising one or more pins on said trigger which  
5 engage one or more angled slots in said outer surface of said  
barrel of said body, said one or more angled slots at an  
angle between 10° and 80° relative to the central  
longitudinal axis of said body, said central longitudinal  
axis of said body identical to said central longitudinal axis  
10 of said trigger;

means for aligning said orifice-containing end of said  
trigger in about the same plane as said open end of said  
body; and

means for centering and guiding said trigger rotatably  
15 in said body about the central longitudinal axis of said  
body.

In a preferred embodiment, the lancet device of the  
present invention is self-activated by the finger (or other  
body part) to be pierced. Depression of the trigger with the  
20 finger releases the lance and the spring so that the needle  
protrudes through an orifice in one end of the trigger and  
pierces the tissue of the finger. Because the spring is held  
in a pre-armed



position, release of the spring is consistent, and reproducibility of incision is well controlled.

Other objects, features and advantages of the present invention will become apparent from the following detailed description when taken in conjunction with the accompanying drawings.

#### BRIEF DESCRIPTION OF THE DRAWINGS

The accompanying drawings, which are incorporated in and form a part of this specification, illustrate embodiments of the invention and, together with the description, serve to explain the principles of the invention:

FIG. 1 shows one embodiment in a longitudinal cross-section through the assembled lancet device.

FIG. 2 is a side view of the lance of the embodiment shown in FIG. 1.

FIG. 3 is a side view of the spring of the embodiment shown in FIG. 1.

FIG. 4 is a side view of the base of the embodiment shown in FIG. 1.

FIG. 5 is a side view of the trigger of the embodiment shown in FIG. 1.

FIG. 6 is a side view of the body of the embodiment shown in FIG. 1.

FIG. 7 shows the lancet device of the embodiment shown in FIG. 1 in firing position.

FIG. 8 shows the lancet device of the embodiment shown in FIG. 1 in the retracted position, after it has been fired.

5 FIG. 9 shows a side view of another embodiment of the assembled lancet device.

FIG. 10 is a side view of the lance of the embodiment shown in FIG. 9.

10

FIG. 11 is a side view of the spring of the embodiment shown in FIG. 9.

15 FIGS. 12a and 12b are side views of the body of the embodiment shown in FIG. 9.

FIG. 13 is a side view of the trigger of the embodiment shown in FIG. 9.

20 FIG. 14 is a longitudinal cross-section through the assembled lancet device of the embodiment shown in FIG. 9.

25 FIG. 15 shows the lancet device of the embodiment shown in FIG. 9 in firing position.

FIG. 16 shows the lancet device of the embodiment shown in FIG. 9 in the retracted position after it has been fired.

30

FIGS. 17a and 17b show side views of the alternate lance for each embodiment.

DETAILED DESCRIPTION OF THE PREFERRED EMBODIMENTS

Reference will now be made in detail to the preferred embodiments of the invention, examples of which are illustrated in the accompanying drawings. While the invention will be described in conjunction with the preferred 5 embodiments, it will be understood that they are not intended to limit the invention to those embodiments. On the contrary, the invention is intended to cover alternatives, modifications and 10 equivalents, which may be included within the spirit and scope of the invention as defined by the appended claims.

One embodiment of the disposable lancet device 100 shown assembled in FIG. 1 and in an exploded view in FIGS. 2-6 comprises a body 42 15 with a lip 46 extending from an aligning ring 52. The trigger 24 is slidably located in barrel 54 of body 42. Its end 30 containing an orifice 32 is aligned so that end 30 is in about the same plane 20 48 as the edge of lip 46 which is at the open end of body 42.

In a preferred embodiment, end 30 of trigger 24 is aligned in plane 48 by means of aligning edge 38 on trigger 24 and aligning ring 25 52 on inner surface 44 of body 42.

Means are provided for guiding and centering trigger 24 in barrel 54 of body 42. In a preferred embodiment, guiding ring 40 of trigger 24 serves this function.

30 The base 14 is fixedly attached to body 42. In a preferred embodiment, this is provided by means of snap fit edge 22 which is in contact with snap fit edge 50 of base 42. Other means of attachment, such as sonic welding, are also 35 possible.



End 12 of spring 8 is fixedly attached to button 13 of base 14. End 10 of spring 8 is fixedly attached to shaft 6 of lance 2. Spring 8, shaft 6 and needle 4 thus provide a lance means.

5 In a preferred embodiment, end 12 is greater in diameter than end 10 to form a tapered spring configuration. Using this tapered spring configuration allows the coils of spring 8 to compress within one another without twisting when

10 they are compressed in an armed position. When a uniform diameter spring is compressed, it may twist or skew. Thus, using a tapered spring helps ensure reproducible release without skewing of the spring. This provides reproducible, centered,

15 piercing force to the lance. In one preferred embodiment, end 12 is about 250 mils in diameter and end 10 is about 150 mils in diameter.

Base 14 comprises retaining means to keep lance 2 and spring 8 in a pre-armed position

20 in well 16. In a preferred embodiment, shaft 6 of lance 2 has an edge 7 which will be caught by clip 20 of arm 18 of base 14 when the lancet device 100 is in the armed position. Spring 8 is compressed, edge 7 is caught by clips 20 of base 14 so that

25 base 14 retains lance 2 and spring 8 in an armed position in well 16. The lance means is thus located in base 14 during manufacture, shipping and storage of the device prior to use.

To use lancet device 100, a body part,

30 such as a finger, to be pierced is placed over orifice 32 and trigger 24 is then depressed. This causes clip-deflecting edges 36 to spread arms 18 and release lance 2 and spring 8. Needle 4 is centered and guided through the hollow center 26

35 of trigger 24 by shaft 6. The force of

decompression of spring 8 pushes needle 4 through orifice 32 to pierce the finger depressing trigger 24. This can be seen in FIG. 7. The depth of penetration of needle 4 is controlled by the  
5 length of the needle and the thickness of end wall 34. Because the body part to be pierced is the body part which depresses trigger 24, this lancet device is self-activating. This feature makes the lancet device of the present invention simple to  
10 use, as it may be operated with one hand. In one preferred embodiment, end wall 34 is 20 to 60 mils thick and the protruding end of needle 4 is 1 to 2.5 mm long.

In another embodiment the disposable  
15 lancet device 200 shown assembled in FIGS. 9 and 14 and in an exploded view in FIGS. 10-13 comprises a body 242. The trigger 224 is slidably located in barrel 254 of body 242. Its end 230 containing an orifice 232 is aligned so that end  
20 230 is in about the same plane 248 as the open end of body 242.

In a preferred embodiment, end 230 of trigger 224 is aligned in plane 248 by means of pins 238 of trigger 224 and slots 246 of body 242.  
25

Means are provided for guiding and centering trigger 224 in barrel 254 of body 242. In a preferred embodiment, pins 238 of trigger 224 and slots 246 of body 242 serve this function as well.  
30

The base 214 is inside barrel 254 of body 242. In a preferred embodiment, base 214 is a portion of the same molded piece as body 242.

Spring 208 is fixedly attached to base 214 at end 212. Spring 208 is fixedly attached to  
35 shaft 206 of lance 202 at end 210. Spring 208,

shaft 206 and needle 204 thus provide a lance means. In a preferred embodiment, end 212 is greater in diameter than end 210 to form a tapered spring configuration. As described in the  
5 previous embodiment, using this tapered spring configuration allows the coils of spring 208 to compress within one another without twisting when they are compressed in an armed position. This provides reproducible, centered, piercing force to  
10 the lance. In one preferred embodiment, end 212 is about 250 mils in diameter and end 210 is about 150 mils in diameter.

Base 214 comprises well 216 wherein lance 202 and spring 208 are loaded and retained.  
15 In a preferred embodiment, shaft 206 of lance 202 has arms 207 which line up with slots 220 in base 214. When trigger 224 is inserted into barrel 254 of base 242, it pushes against arms 207 of lance 202, sliding the lance into well 216 of base 214.  
20 This compresses spring 208. When pins 238 of trigger 224 engage slots 246 of body 242, they snap in place, retaining lance 202 and spring 208 in a compressed, armed position in well 216. The lance means is thus located pre-armed in base 214  
25 during manufacture, shipping and storage of the device prior to use.

To use lancet device 200, a body part, such as a finger, to be pierced is placed over orifice 232 and trigger 224 is then depressed.  
30 Pins 238 sliding in angled slots 246 cause trigger 224 to rotate. When trigger 224 is fully depressed slots 236 are aligned with slots 220 of base 214. This releases lance 202 and spring 208. Slots 246 can be at angles from 10° to 80°. In a

preferred embodiment, the angle of slots 246 can be from 30° to 60°.

Lance 202 is centered and guided by shaft 206 and arms 207 within base 214. The force of decompression of spring 208 pushes needle 204 through orifice 232 to pierce the finger depressing trigger 224. This can be seen in FIG. 15. The depth of penetration of needle 204 is controlled by the length of the needle and the thickness of end wall 234. Because the body part to be pierced is the body part which depresses trigger 224, this lancet device is self-activating. This feature makes the lancet device of the present invention simple to use, as it may be operated with one hand. In one preferred embodiment, end wall 234 is 20 to 60 mils thick and the protruding portion of needle 204 is 1 to 2.5 mm long.

In either embodiment, when the spring completes its over-extension after release and returns to its regular, un-armed length, the needle is completely within the trigger, so there is little or no danger of accidental needle exposure from the device after use. This can be seen in FIGS. 8 and 16.

The shaft of the lance is greater in diameter than the orifice in the trigger to prevent over-extension of the needle. The orifice is greater in diameter than the needle to allow easy withdrawal of the needle back into the hollow center of the trigger.

In either embodiment, more than one needle may be included in the lance. This alternate configuration may provide a more suitable incision for some uses. In preferred

embodiments, as seen in FIGS. 17a and 17b, two needles are used.

Various dimensions, shapes and structures can be used for the various components  
5 of the lancet device of the present invention.

The body, trigger, shaft, edge, and base may be circular, oval, square, rectangular or other appropriate shape in cross-section.

Conveniently, the base, trigger and body  
10 are injection molded using an appropriate plastics material. In a preferred embodiment, they are made of polystyrene.

The lancet device of the present invention may be utilized for human or veterinary  
15 use.

The foregoing descriptions of specific embodiments of the present invention have been presented for purposes of illustration and description. They are not intended to be  
20 exhaustive or to limit the invention to the precise forms disclosed, and it should be understood that many modifications and variations are possible in light of the above teaching. The embodiments were chosen and described in order to  
25 best explain the principles of the invention and its practical application, to thereby enable others skilled in the art to best utilize the invention and various embodiments with various modifications as are suited to the particular use  
30 contemplated. It is intended that the scope of the invention be defined by the Claims appended hereto and their equivalents.

THE CLAIMS DEFINING THE INVENTION ARE AS FOLLOWS:-

1. A lancet device having an armed state from which it can  
be released to pierce human or animal tissue, the device  
5 comprising:

a lance, including a needle and a shaft with one or more  
arms; a spring, one end of which is fixedly attached to said  
shaft of said lance; a base, including a well wherein said  
lance and spring are located; means for fixedly attaching the  
10 other end of said spring to said base;

a trigger, including a barrel to slidably accept said  
lance and having one or more slots to slidably engage said  
one or more arms of said lance when said device is released  
from the armed state, means for retaining said lance and  
15 spring in a compressed armed position prior to use, an end  
with an orifice to allow said needle to protrude through said  
orifice when said lance and spring are released from said  
armed position to pierce human or other animal tissue, and  
rotational means for rotating said trigger about its central  
20 longitudinal axis to rotatably align each said slot with one  
of said arms such that said arms are slidably engaged in said  
slots thereby releasing said lance and said spring from said  
armed position during use;

means for controlling the depth of penetration of said  
25 needle into said tissue;

a body, including a barrel having an outer surface and  
a hollow center to slidably accept said trigger and fixedly  
accept said base, an open end distal from said base, said  
open end being in about the same plane as the face of said  
30 orifice-containing end of said trigger when said trigger is  
inserted into said body, and means for retaining said trigger  
in said barrel:

means for fixedly attaching said base to said body;

means for aligning said orifice-containing end of said  
35 trigger in about the same plane as said open end of said  
body; and

means for centering and guiding said trigger rotatably



in said body about the central longitudinal axis of said body, said central longitudinal axis of said body identical to said central longitudinal axis of said trigger.

- 5 2. A device as in Claim 1, wherein said lance includes a plurality of needles.
3. A device as in Claim 1 wherein said means for retaining said lance and said spring in a compressed armed position  
10 prior to use comprises one or more pins on said trigger which engage one or more angled slots in said outer surface of said barrel of said body.
4. A device as in Claim 1 wherein said means for  
15 controlling comprises said orifice-containing end of said trigger having a specific wall thickness and said needle having a specific length.
5. A device as in Claim 1 wherein said rotational means for  
20 rotating said trigger about its central longitudinal axis to rotatably release said lance and spring comprises one or more pins on said trigger which engage one or more angled slots in said outer surface of said barrel of said body wherein rotation is caused by depressing said trigger.
- 25 6. A device as in Claim 5 wherein said trigger is depressed by a human or animal body part to be pierced by said needle.
7. A device as in Claim 1 wherein said means for attaching  
30 said base comprises molding said base and said body as a single piece.
8. A device as in Claim 1 wherein said means for centering and guiding said trigger comprises one or more pins on said  
35 trigger engaged with one or more angled slots in said outer surface of said barrel of said body.



9. A device as in Claim 1 wherein said means for aligning said trigger comprises one or more pins on said trigger engaged with one or more angled slots in said outer surface of said barrel of said body.

5

10. A device as in Claim 1 wherein said base, trigger and body are made of polystyrene.

11. A device as in Claim 1 wherein said base, trigger and  
10 body are injection molded.

12. A device as in Claim 5 wherein said one or more angled slots are at an angle between 10° and 80° relative to the central longitudinal axis of said body.

15

13. A lancet device, comprising:

a lance, including a needle of a specific length and a shaft with one or more arms;

a spring, one end of which is fixedly attached to said  
20 shaft of said lance;

a trigger, including a barrel with an outer surface, one or more slots and a hollow center to slidably accept said lance, an end having a specific wall thickness and an orifice, an end distal from said orifice-containing end to  
25 engage said arms of said lance to compress said spring, and one or more pins on said outer surface;

a body, including a barrel, a hollow center to slidably accept said trigger, a base with a well wherein said lance and spring are located in a compressed armed position prior  
30 to use, one or more angled slots in said barrel for engaging said pins of said trigger, and an end distal from said base being in about the same plane as the face of said orifice-containing end of said trigger when said pins of said trigger are engaged in said slots of said body;

35 means for fixedly attaching the other end of said spring to said base;

one or more slots in said base to slidably accept said





arms of said lance;

said distal end of said trigger retaining said lance and spring in said compressed armed position in said well when said pins in said trigger are engaged in the top of said  
5 angled slots of said body; and

said angled slots of said body guiding said pins of said trigger to rotate said trigger when said trigger is depressed so that said slots of said trigger align with said slots of said base and said arms of said lance to release said lance  
10 and spring to allow said needle to protrude through said orifice to pierce human or other animal tissue.

14. A lancet device having an armed state from which it can be released to pierce human or animal tissue, the device  
15 comprising:

a lance, including a needle and a shaft with one or more arms;

a base, including a well wherein said lance is located, said well having a bottom;

20 a spring, located in said well between said shaft of said lance and said bottom of said well;

a trigger, including a barrel to slidably accept said lance and having one or more slots to slidably engage said one or more arms of said lance;

25 when said device is released from the armed state, means for retaining said lance and spring in a compressed armed position prior to use, an end with an orifice to allow said needle to protrude through said orifice when said lance and spring are released from said armed position to pierce human  
30 or other animal tissue, and rotational means for rotating said trigger about its central longitudinal axis to rotatably align each said slot with one of said arms such that said arms are slidably engaged in said slots thereby releasing said lance and spring from said armed position during use;

35 means for controlling the depth of penetration of said needle into said tissue;

a body, including a barrel to slidably accept said



trigger and fixedly accept said base, an open end distal from said base, said open end being in about the same plane as the face of said orifice-containing end of said trigger when said trigger is inserted into said body, and means for retaining

5 said trigger in said barrel;

means for fixedly attaching said base to said body;

means for aligning said orifice-containing end of said trigger in about the same plane as said open end of said body; and

10 means for centering and guiding said trigger rotatably in said body about the central longitudinal axis of said body, said central longitudinal axis of said body identical to said central longitudinal axis of said trigger.

15 15. A lancet device, comprising:

a lance, including a needle and a shaft with one or more arms:

a base, including a well wherein said lance is located, said well having a bottom;

20 a spring, located in said well between said shaft of said lance and said bottom of said well;

means for retaining said lance and spring in a compressed armed position prior to use;

25 a trigger, including a barrel with an outer surface, one or more longitudinal slots and a hollow center to slidably accept said lance, an end having an orifice, and one or more pins on said outer surface;

30 a body, including a barrel to slidably accept said trigger and fixedly accept said base, one or more angled slots in said barrel for engaging said one or more pins on said outer surface of said trigger, and an end distal from said base being in about the same plane as the face of said orifice-containing end of said trigger when said one or more pins of said trigger are engaged in said one or more angled slots of said body; and

said one or more angled slots of said body guiding said one or more pins of said trigger to rotate said trigger about



the central longitudinal axis of said body when said trigger is depressed so that said one or more longitudinal slots of said trigger align with said one or more arms of said lance, releasing said lance and spring to allow said needle to protrude through said orifice to pierce human or other animal tissue.

16. A lancet device, comprising:

a lance, including a needle and a shaft;

10 a spring, one end of which is fixedly attached to said shaft of said lance;

a base, including a well wherein said lance and spring are located;

15 means for fixedly attaching the other end of said spring to said base;

a trigger, including a barrel to slidably accept said lance, means for retaining said lance and spring in a compressed armed position prior to use, an end with an orifice to allow said needle to protrude through said orifice when said lance and spring are released from said armed position to pierce human or other animal tissue, and rotational means for rotating said trigger about its central longitudinal axis to rotatably release said lance and said spring from said armed position during use;

25 means for controlling the depth of penetration of said needle into said tissue;

a body, including a barrel having an outer surface and a hollow center to slidably accept said trigger and fixedly accept said base, an open end distal from said base, said open end being in about the same plane as the face of said orifice-containing end of said trigger when said trigger is inserted into said body, and means for retaining said trigger in said barrel;

means for fixedly attaching said base to said body;

35 said rotational means for rotating said trigger about its central longitudinal axis to rotatably release said lance and spring comprising one or more pins on said trigger which



engage one or more angled slots in said outer surface of said barrel of said body, said one or more angled slots at an angle between 10° and 80° relative to the central longitudinal axis of said body, said central longitudinal axis of said body identical to said central longitudinal axis of said trigger;

means for aligning said orifice-containing end of said trigger in about the same plane as said open end of said body; and

means for centering and guiding said trigger rotatably in said body about the central longitudinal axis of said body.

17. A lancet device substantially as hereinbefore described with reference to Figures 9 to 17 of the accompanying drawings.

Dated this 14th day of February, 1996

URS A. RAMEL  
By his Patent Attorneys  
Davies Collison Cave

25



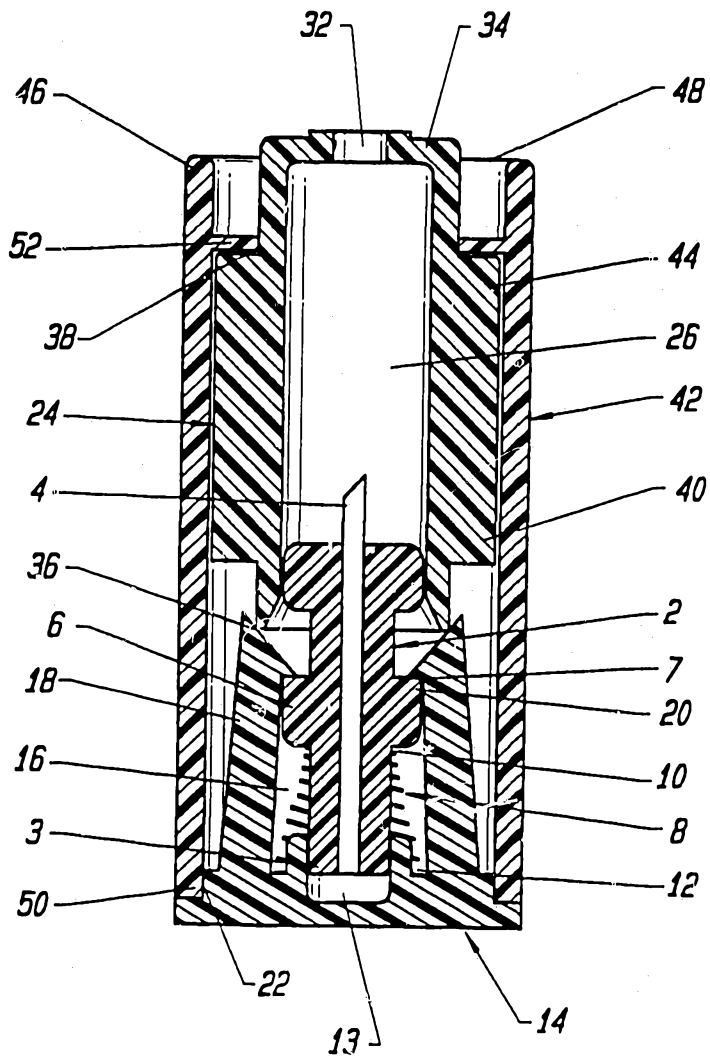

FIG. 1

FIG. 6

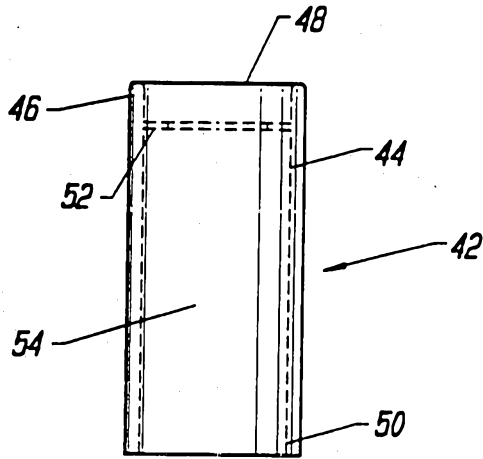

FIG. 5

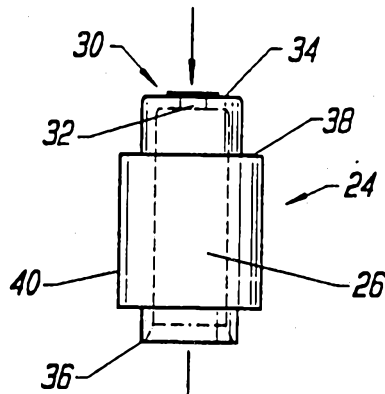

FIG. 2

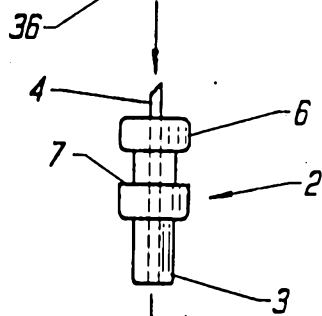

FIG. 3

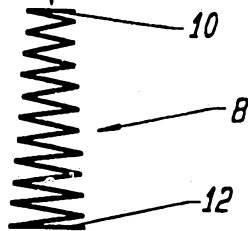
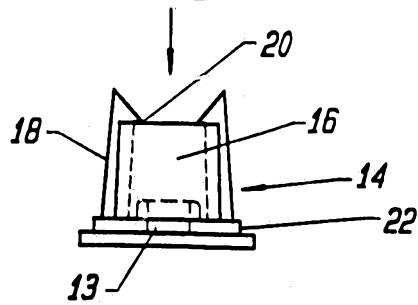

FIG. 4



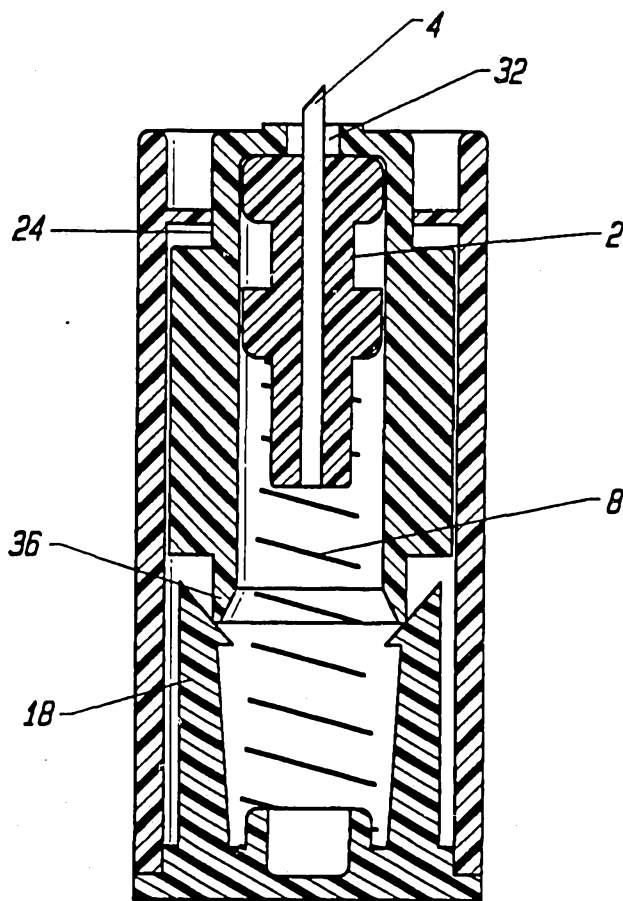

FIG. 7

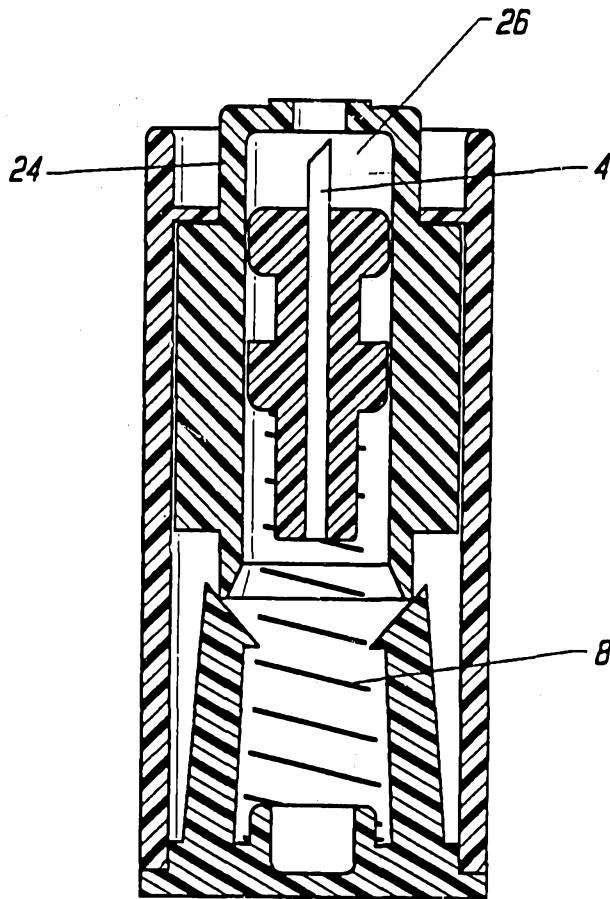

FIG. 8



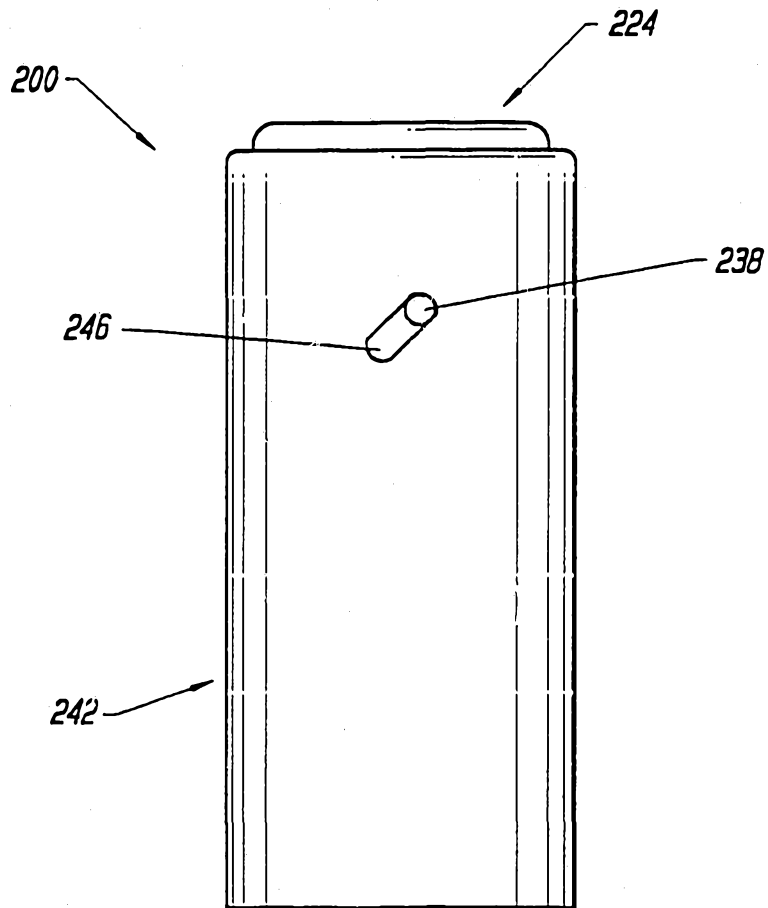
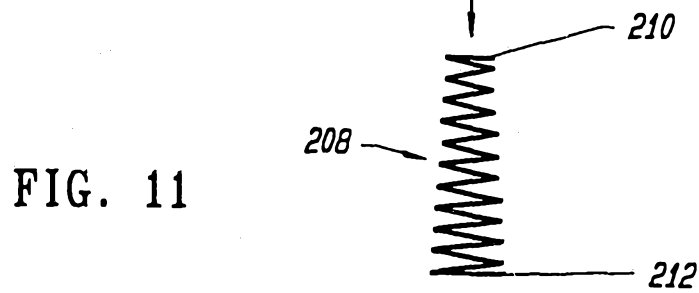
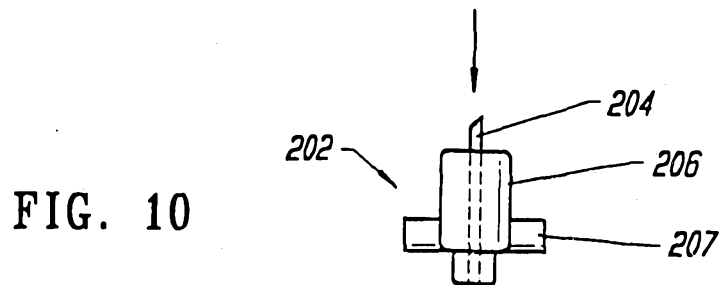
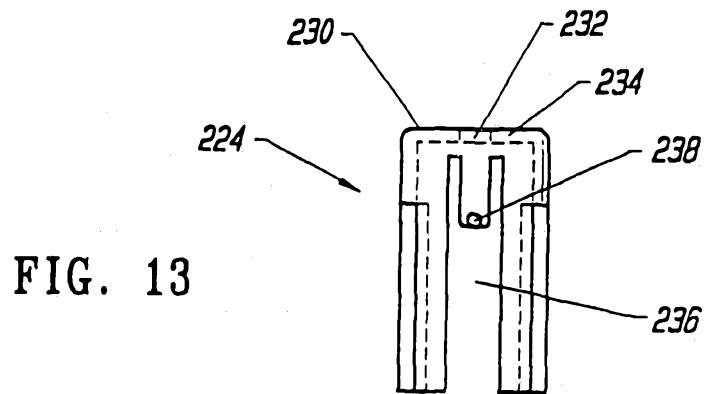

FIG. 9



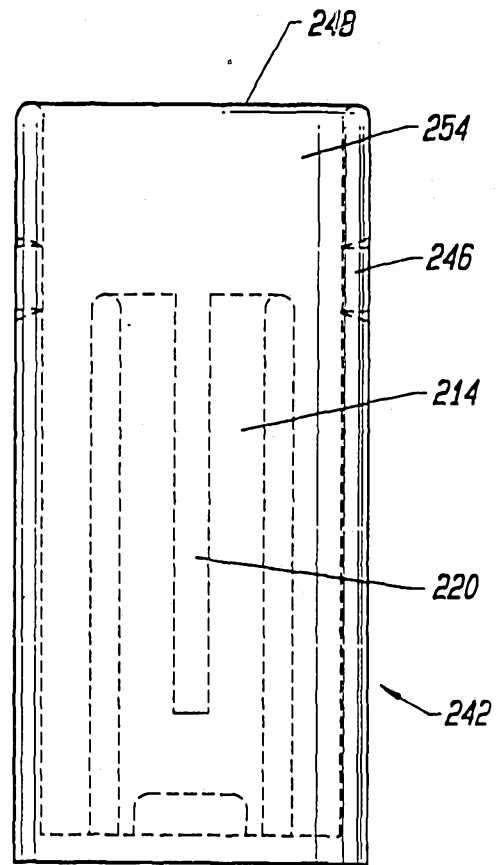
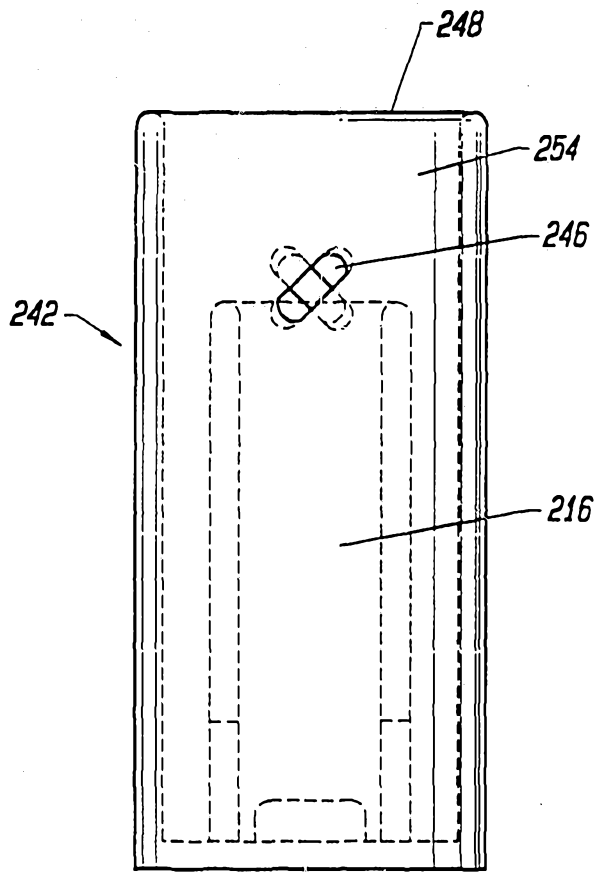

FIG. 12A

FIG. 12B

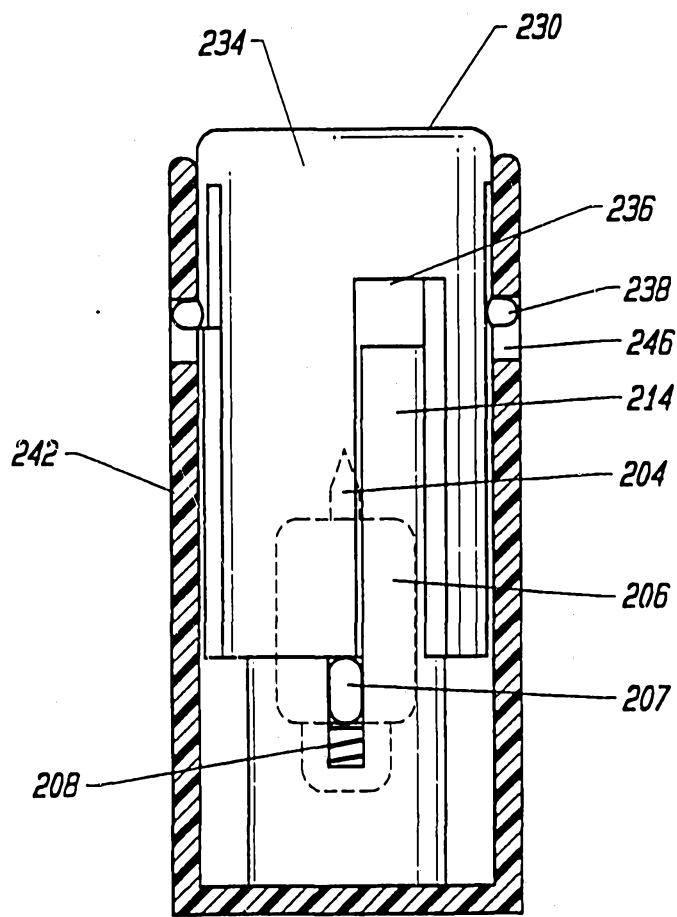

FIG. 14

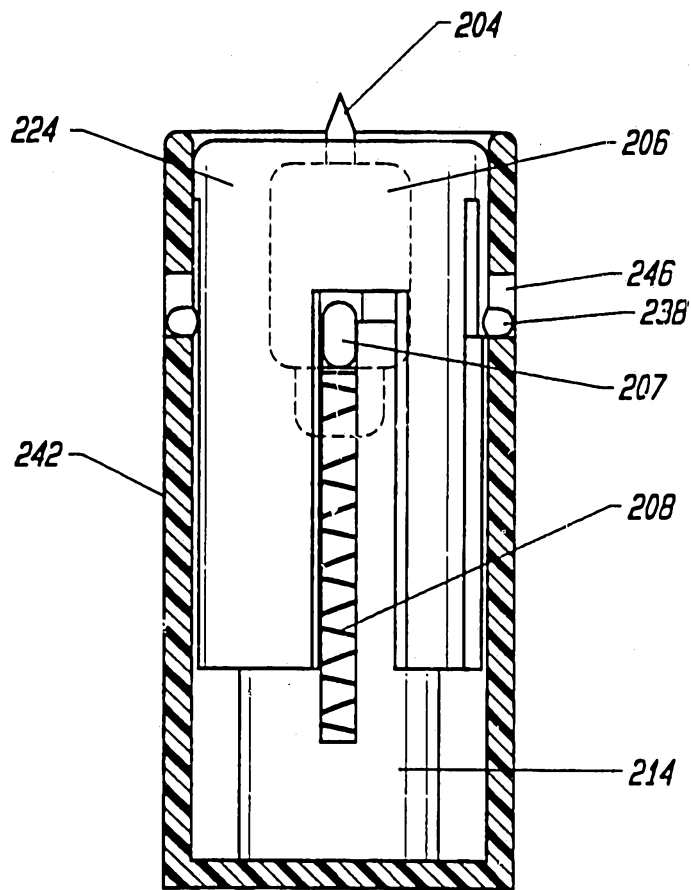

FIG. 15

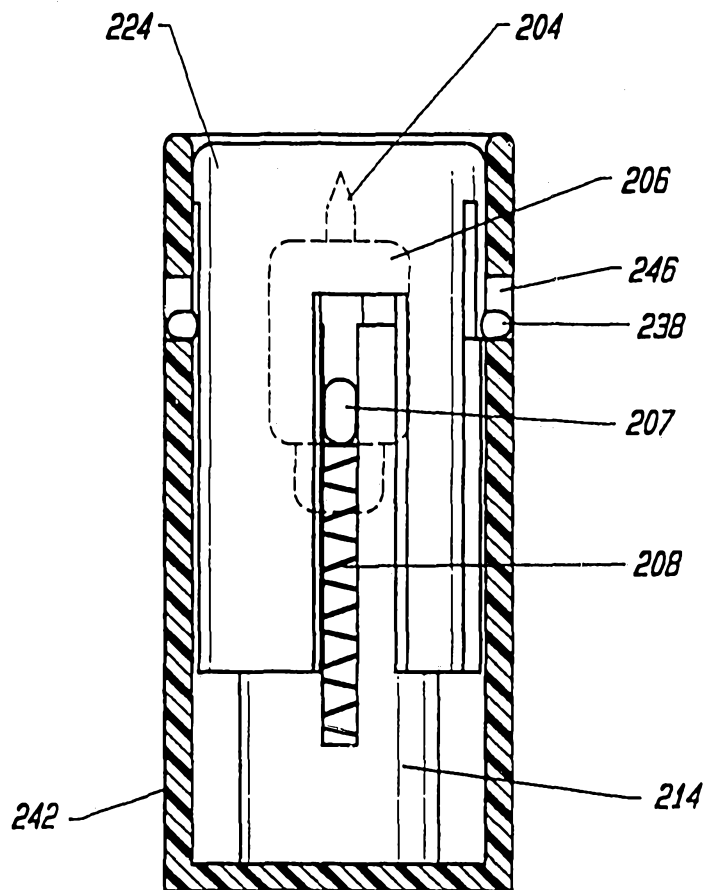

FIG. 16

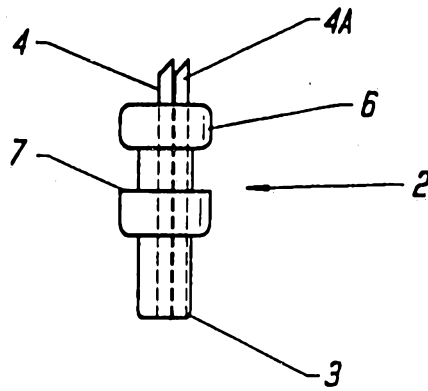

FIG. 17A

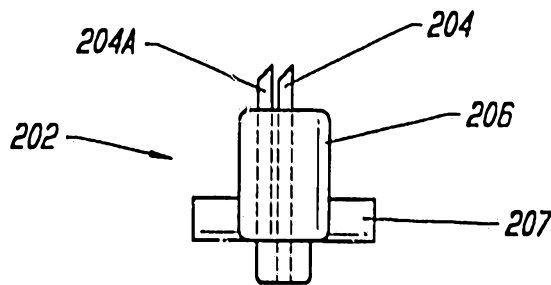

FIG. 17B

INTERNATIONAL SEARCH REPORT

PCT/US92/09456

**A. CLASSIFICATION OF SUBJECT MATTER**

IPC(5) :A61B 17/32  
US CL :606/183,182

According to International Patent Classification (IPC) or to both national classification and IPC

**B. FIELDS SEARCHED**

Minimum documentation searched (classification system followed by classification symbols)

U.S. : 606/185,186; 604/137,157

Documentation searched other than minimum documentation to the extent that such documents are included in the fields searched

Electronic data base consulted during the international search (name of data base and, where practicable, search terms used)

**C. DOCUMENTS CONSIDERED TO BE RELEVANT**

Category*	Citation of document, with indication, where appropriate, of the relevant passages	Relevant to claim No.
X Y	US,A, 4,817,603 (TURNER ET AL) 04 APRIL 1989 See entire document	1,17,19-28 2-16,18
Y	US,A, 3,208,452 (STERN) 28 SEPTEMBER 1965 See entire document	11,18
Y	US,A, 4,653,513 (Dombrowski) 31 MARCH 1987 See entire document	2-16
Y	US,A, 5,026,388 (INGALZ) 25 JUNE 1991 See entire document	5,16

Further documents are listed in the continuation of Box C.  See patent family annex.

* Special categories of cited documents:	*T	later document published after the international filing date or priority date and not in conflict with the application but cited to understand the principle or theory underlying the invention
*A* document defining the general state of the art which is not considered to be part of particular relevance	*X*	document of particular relevance; the claimed invention cannot be considered novel or cannot be considered to involve an inventive step when the document is taken alone
*E* earlier document published on or after the international filing date	*Y*	document of particular relevance; the claimed invention cannot be considered to involve an inventive step when the document is combined with one or more other such documents, such combination being obvious to a person skilled in the art
*L* document which may throw doubt on priority claim(s) or which is cited to establish the publication date of another citation or other special reason (as specified)	*&*	document member of the same patent family
*O* document referring to an oral disclosure, use, exhibition or other means		
*P* document published prior to the international filing date but later than the priority date claimed		

Date of the actual completion of the international search: 08 DECEMBER 1992	Date of mailing of the international search report 21 JAN 1993
Name and mailing address of the ISA/ Commissioner of Patents and Trademarks Box PCT Washington, D.C. 20231 Facsimile No. NOT APPLICABLE	Authorized officer <i>H. Thaler</i> MICHAEL THALER Telephone No. (703) 308-2981