



US00D368680S

United States Patent [19]
Freeman

[11] **Patent Number:** **Des. 368,680**
[45] **Date of Patent:** ****Apr. 9, 1996**

[54] **COMBINED BICYCLE AND CART**
[76] Inventor: **Richard D. Freeman**, 400 John C
Hunter Rd., Sharpsburg, Ga. 30277
[**] Term: **14 Years**
[21] Appl. No.: **34,194**
[22] Filed: **Jan. 30, 1995**
[52] **U.S. Cl.** **D12/113**
[58] **Field of Search** D12/109, 112,
D12/113; 280/202, 273, 282, 761, 7.16

D. 304,813 11/1989 Kelly D12/113
D. 310,983 10/1990 Goldmeir D12/112
1,218,943 3/1917 Hudry D12/113

Primary Examiner—A. Hugo Word
Assistant Examiner—M. Brown
Attorney, Agent, or Firm—Terry M. Gernstein

[57] **CLAIM**

The ornamental design for a combined bicycle and cart, as shown and described.

DESCRIPTION

FIG. 1 is a front, top and side perspective view of the combined bicycle and cart showing my new design; FIG. 2 is a front elevational view thereof; FIG. 3 is a rear elevational view thereof; FIG. 4 is a side elevational view thereof, the side opposite being a mirror image of the side shown in FIG. 4; FIG. 5 is a top plan view thereof; and, FIG. 6 is a bottom plan view thereof.

[56] **References Cited**

U.S. PATENT DOCUMENTS

D. 149,413 4/1948 Jackson D12/113
D. 158,455 5/1950 Glamb D12/113
D. 159,103 6/1950 Smith D12/113
D. 162,622 3/1951 Boone D12/113
D. 176,037 11/1955 Rhoades D12/113
D. 176,584 1/1956 Barone D12/109
D. 225,348 12/1972 Garrett D12/109
D. 250,404 11/1978 Reese D12/109

1 Claim, 4 Drawing Sheets

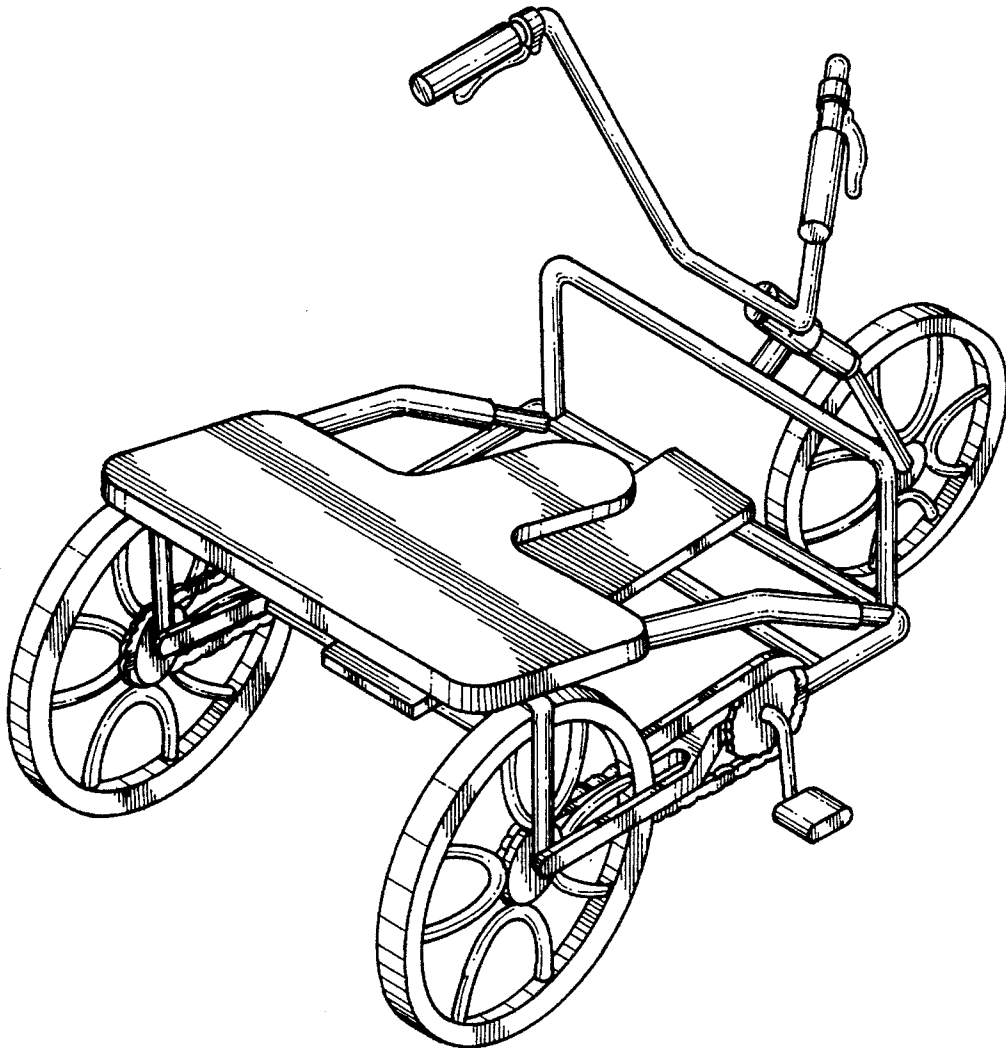

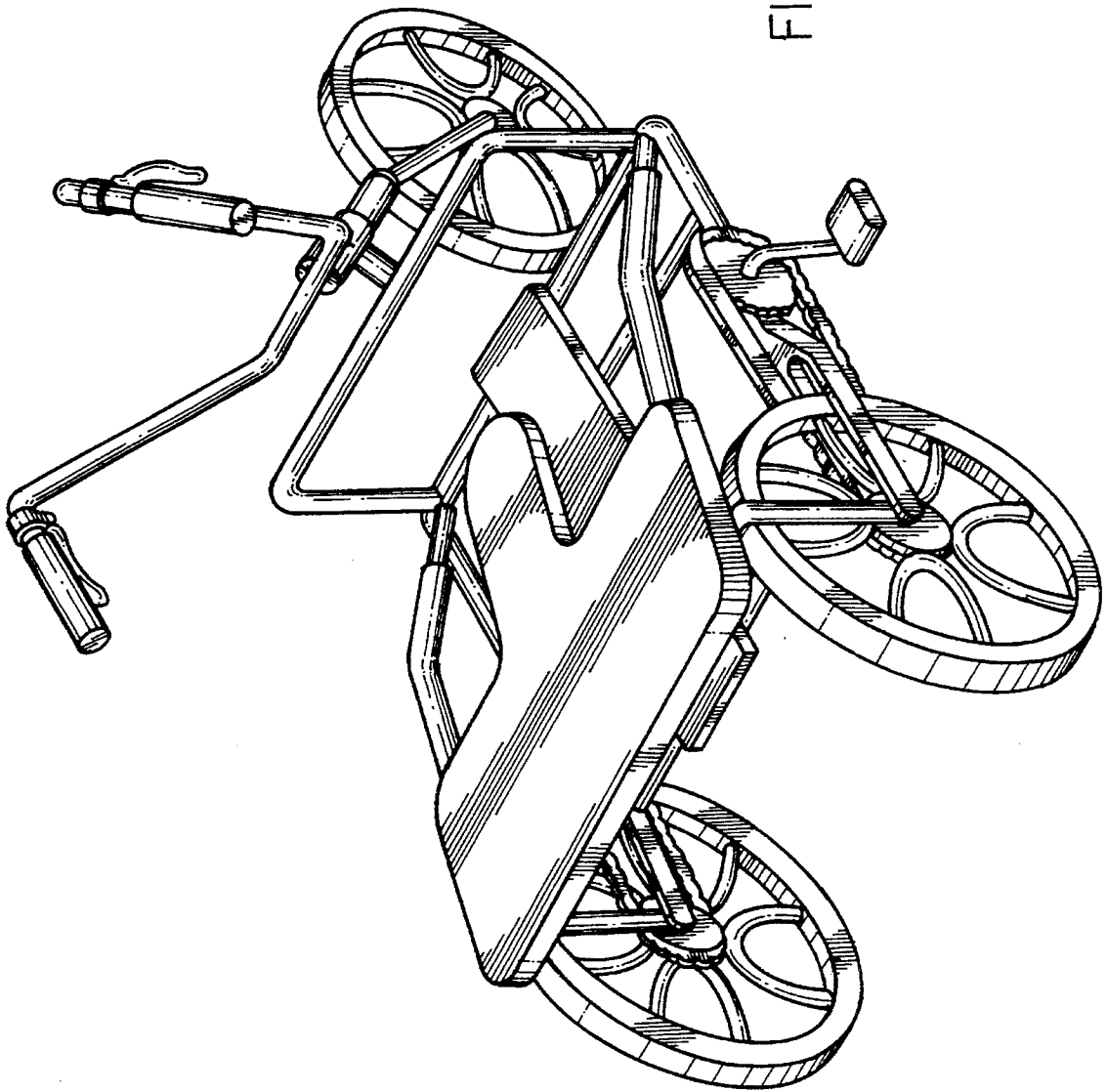

FIG.1.

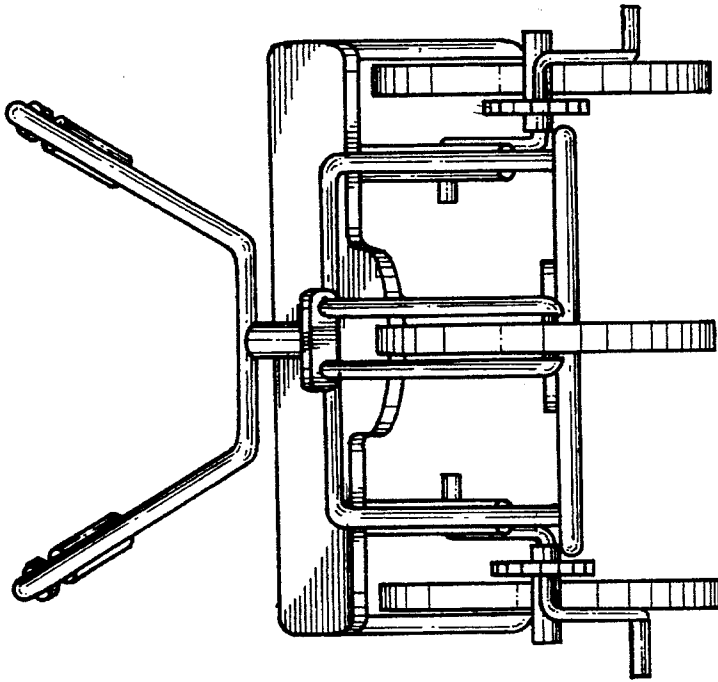

FIG. 2.

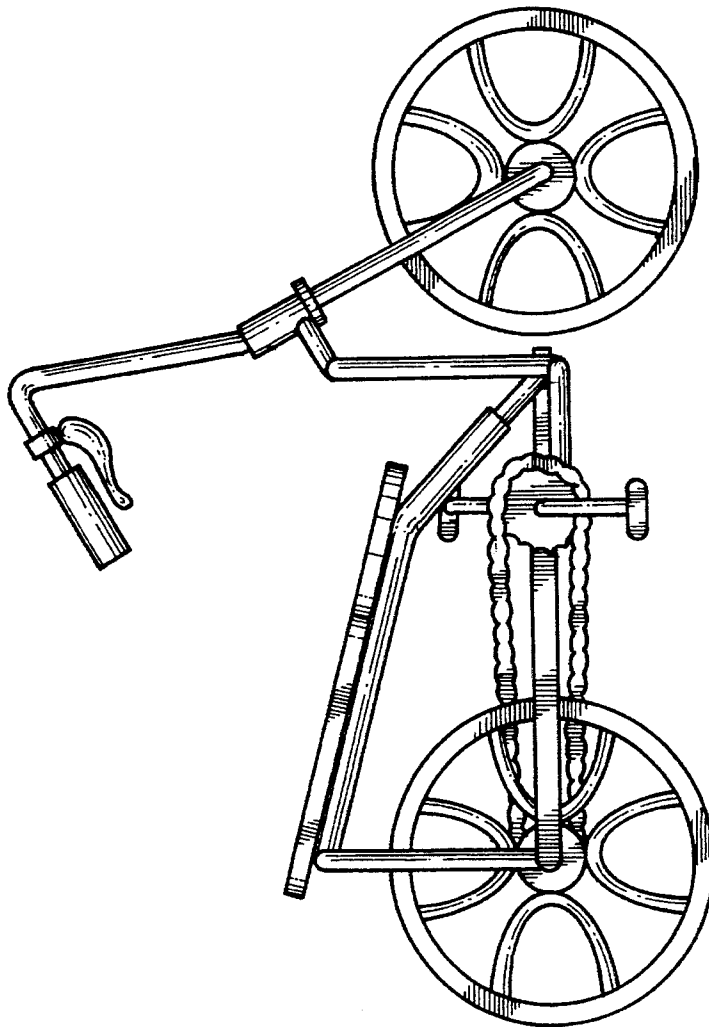

FIG. 4.

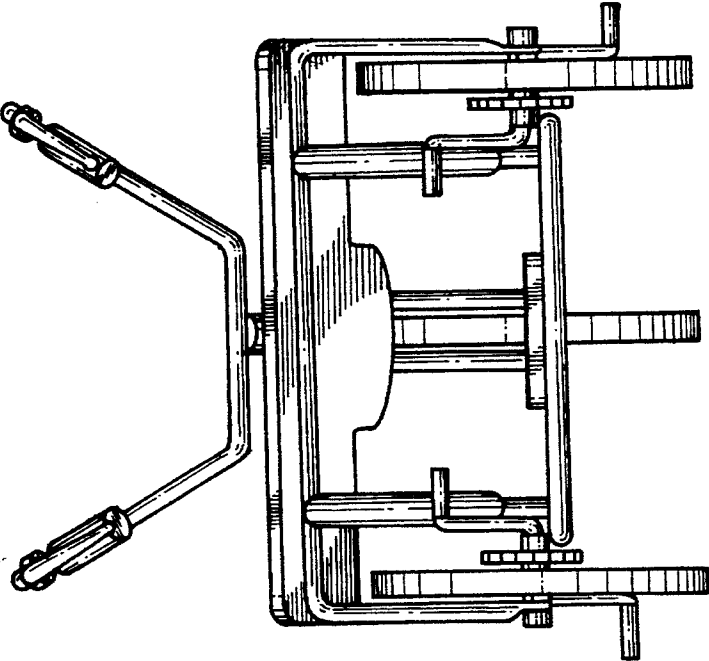

FIG. 3.

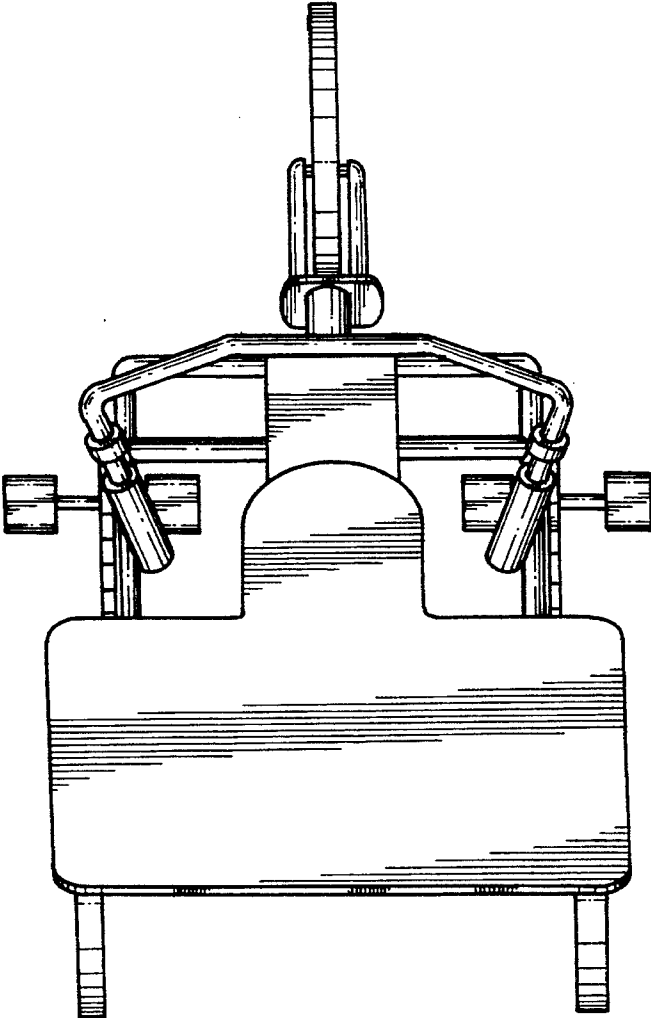

FIG. 5.

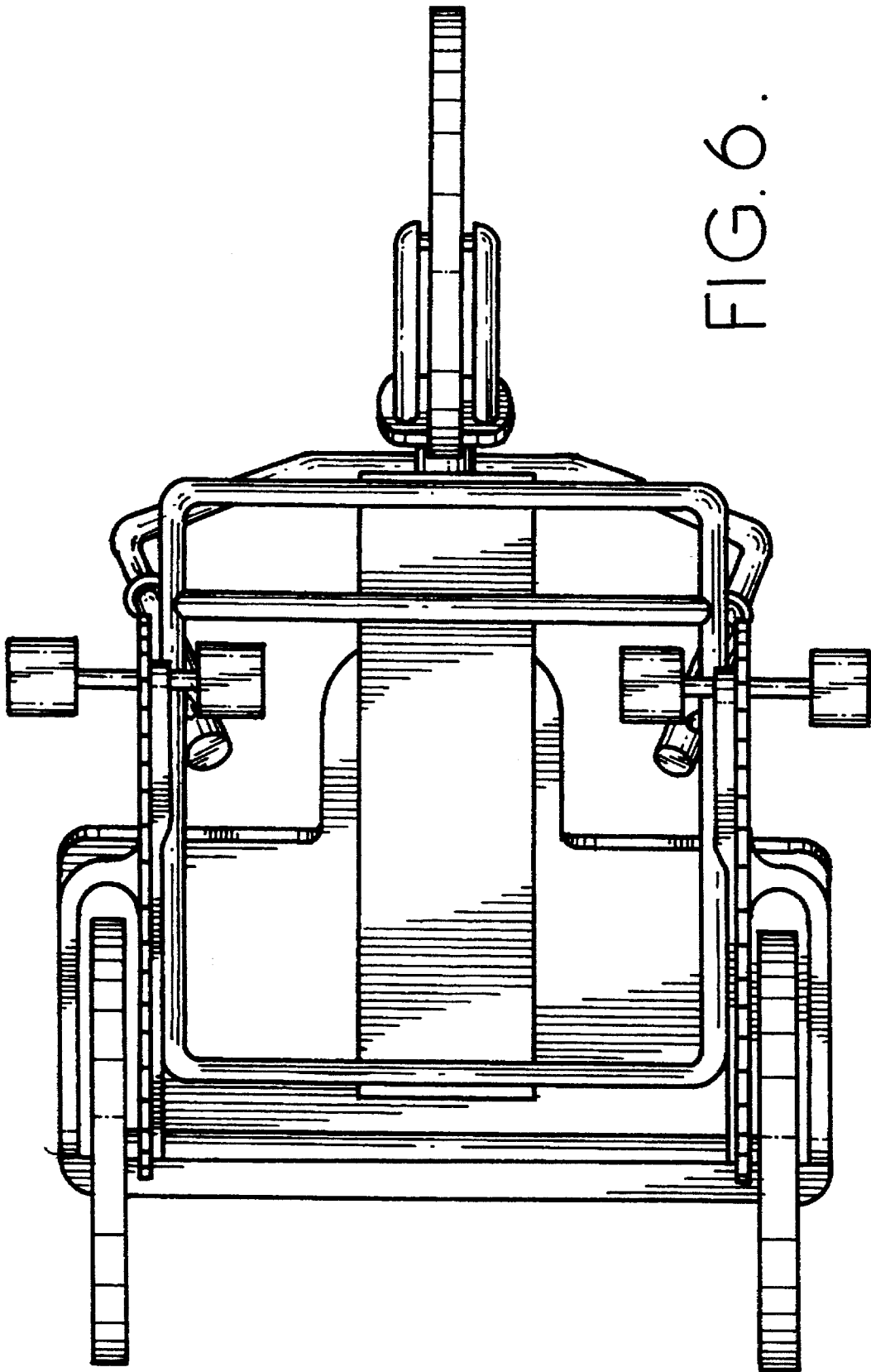

FIG. 6.