



(19) **United States**

(12) **Patent Application Publication**

Rissa et al.

(10) **Pub. No.: US 2013/0093753 A1**

(43) **Pub. Date: Apr. 18, 2013**

(54) **AUTO-STEREOSCOPIIC DISPLAY CONTROL**

(52) **U.S. Cl.**

(75) Inventors: **Tero Pekka Rissa**, Siivikkala (FI); **Aki Petri Happonen**, Kiiminki (FI)

USPC **345/419; 345/522**

(73) Assignee: **NOKIA CORPORATION**, Espoo (FI)

(57) **ABSTRACT**

(21) Appl. No.: **13/274,047**

(22) Filed: **Oct. 14, 2011**

An apparatus, a method and a non-transitory computer readable medium is provided. The apparatus includes: at least one processor; and at least one memory storing computer program instructions configured, working with the at least one processor, to cause the apparatus to perform at least the following: detecting bending of a flexible auto-stereoscopic display; and adjusting a parallax barrier arrangement of the flexible auto-stereoscopic display in dependence upon the bending of the flexible auto-stereoscopic display.

Publication Classification

(51) **Int. Cl.**

G06T 15/00 (2011.01)
G06T 1/00 (2006.01)

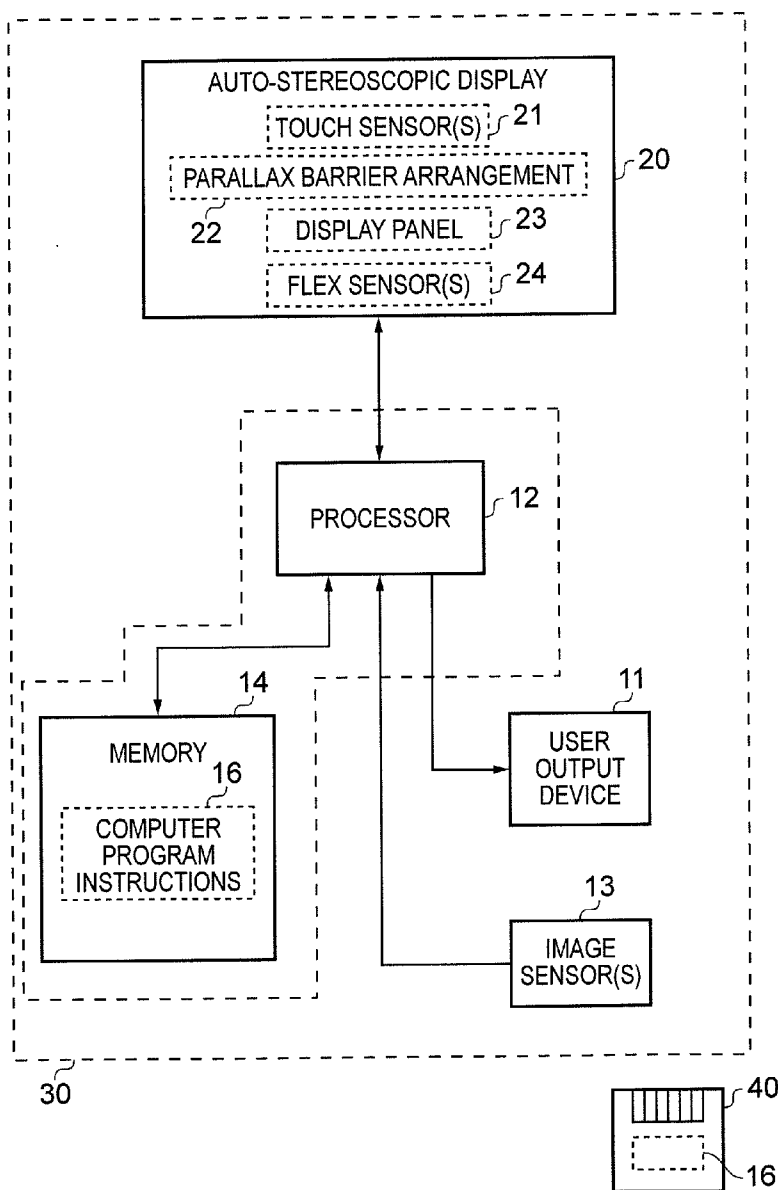

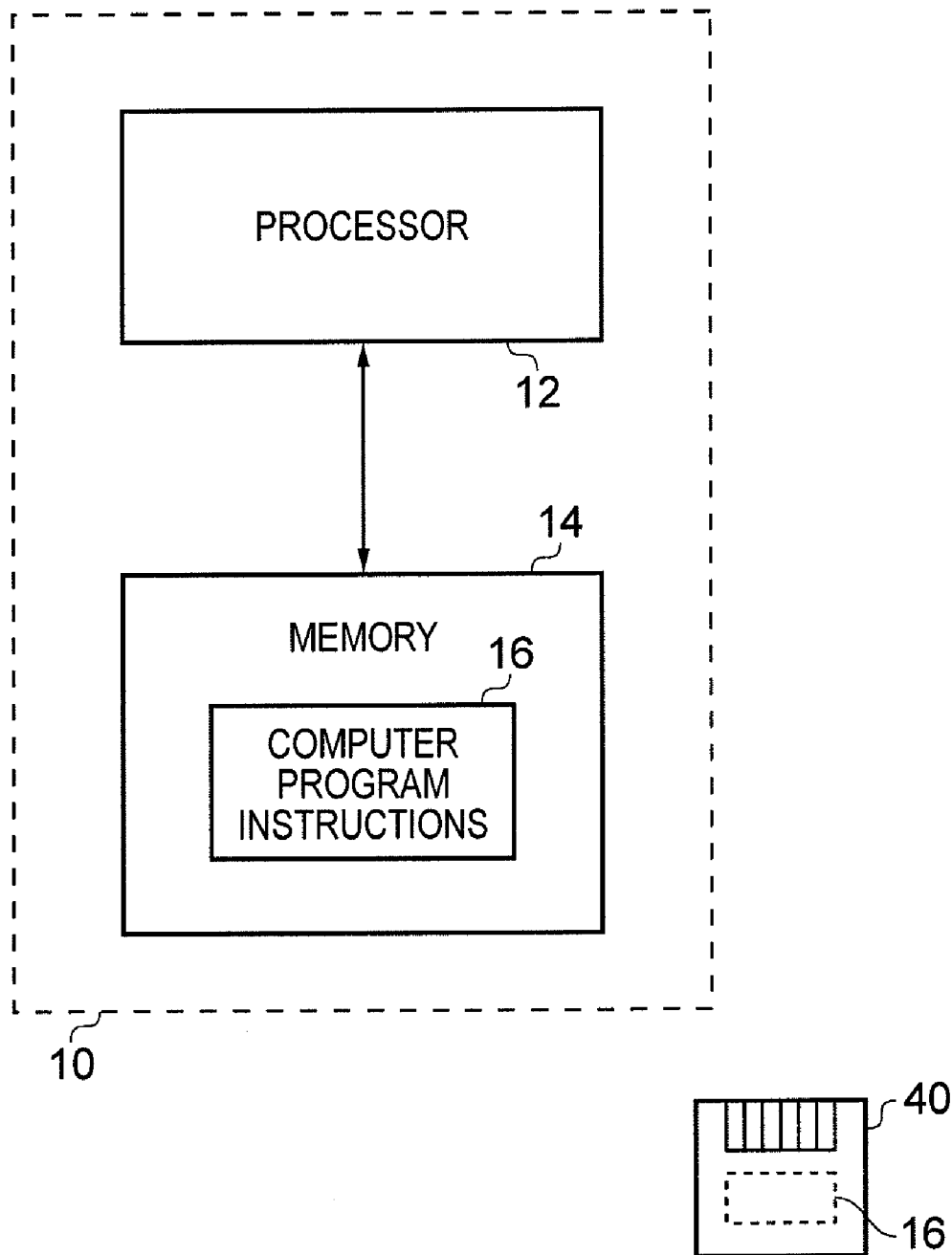

FIG. 1

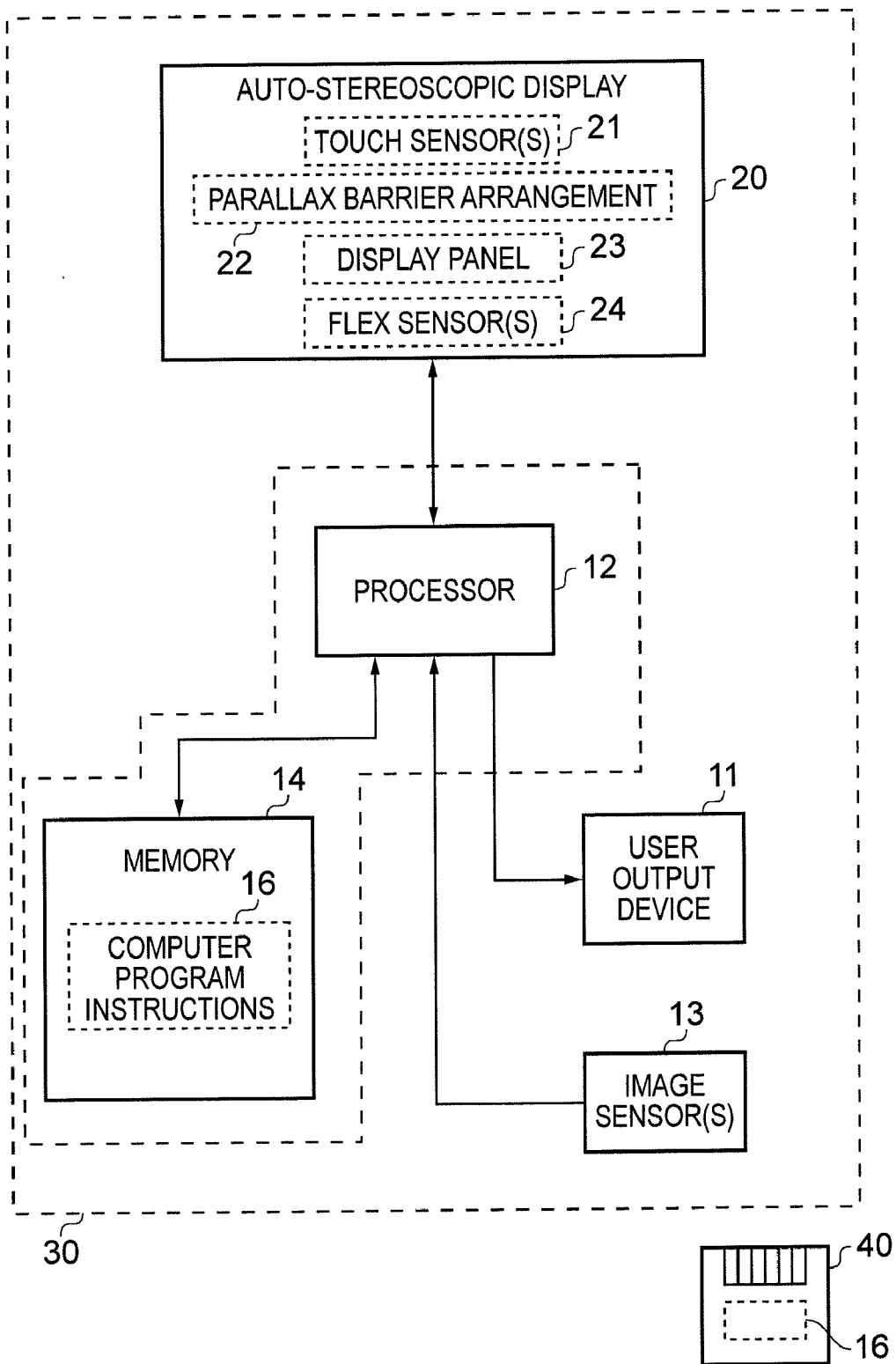

FIG. 2

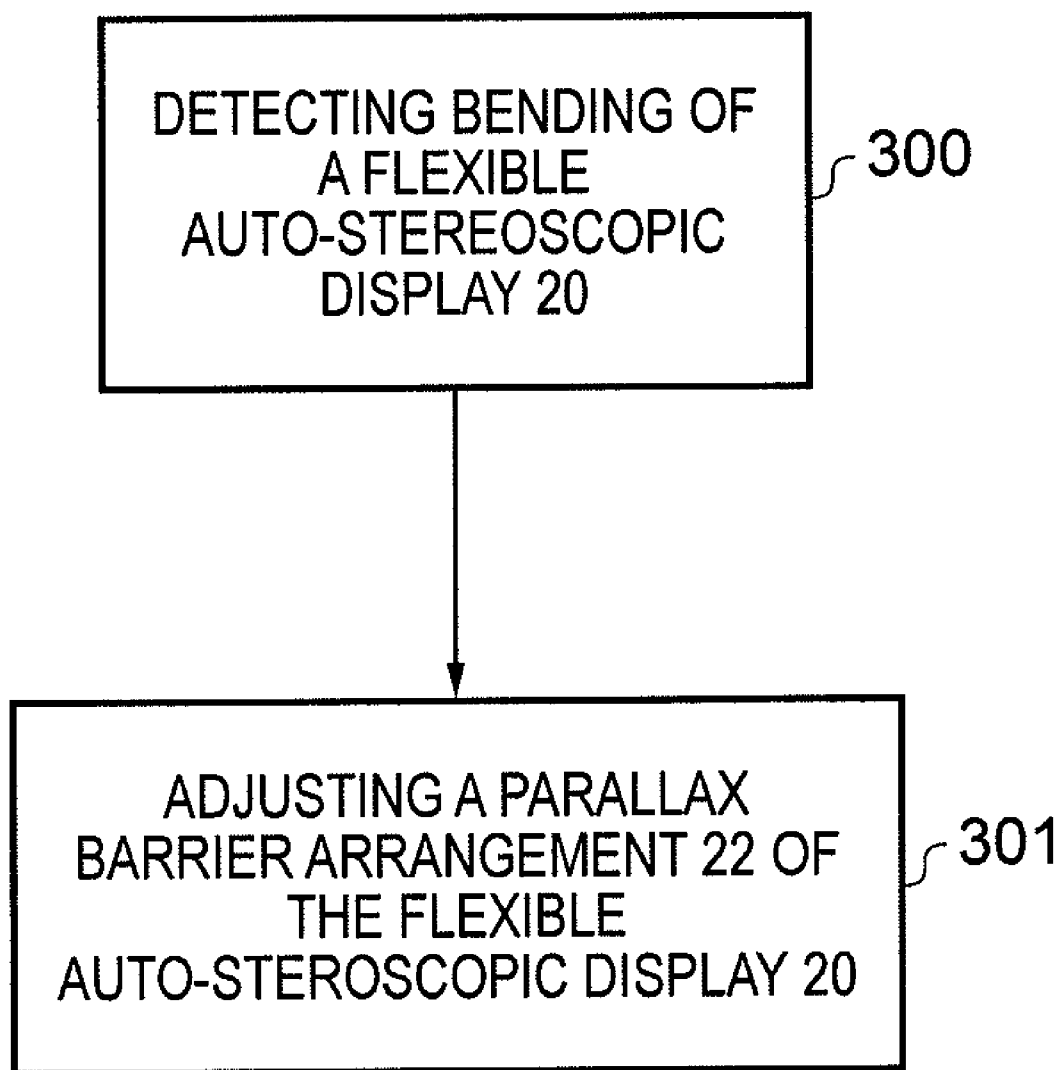

FIG. 3

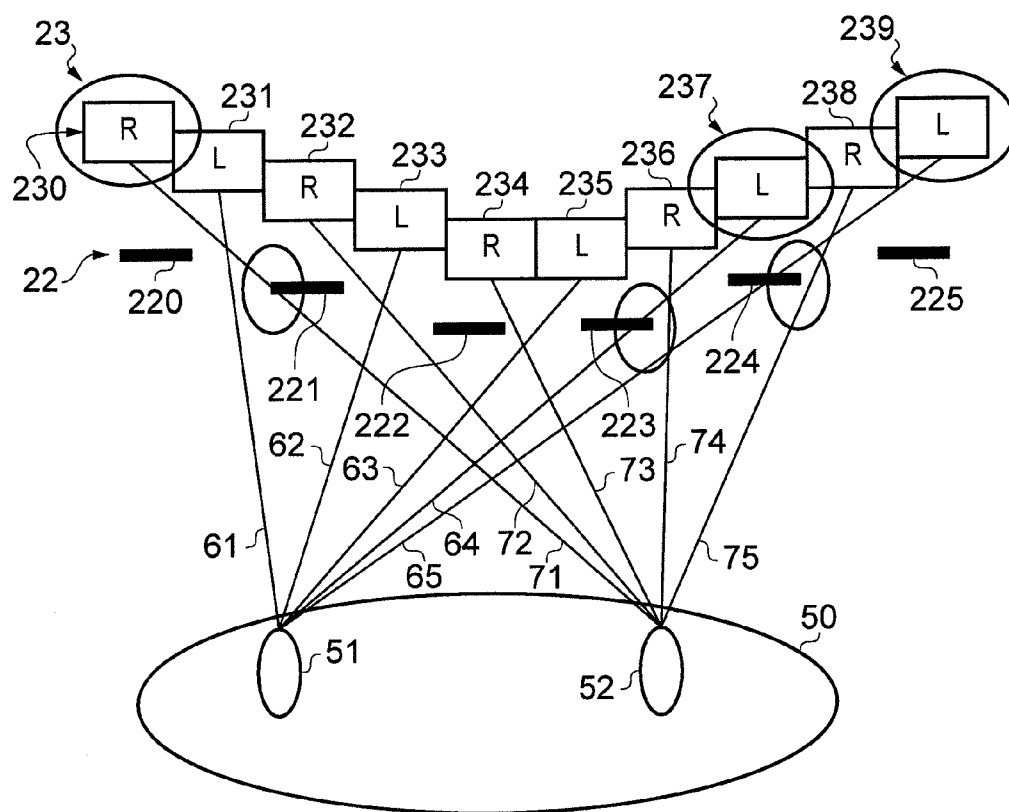

FIG. 4

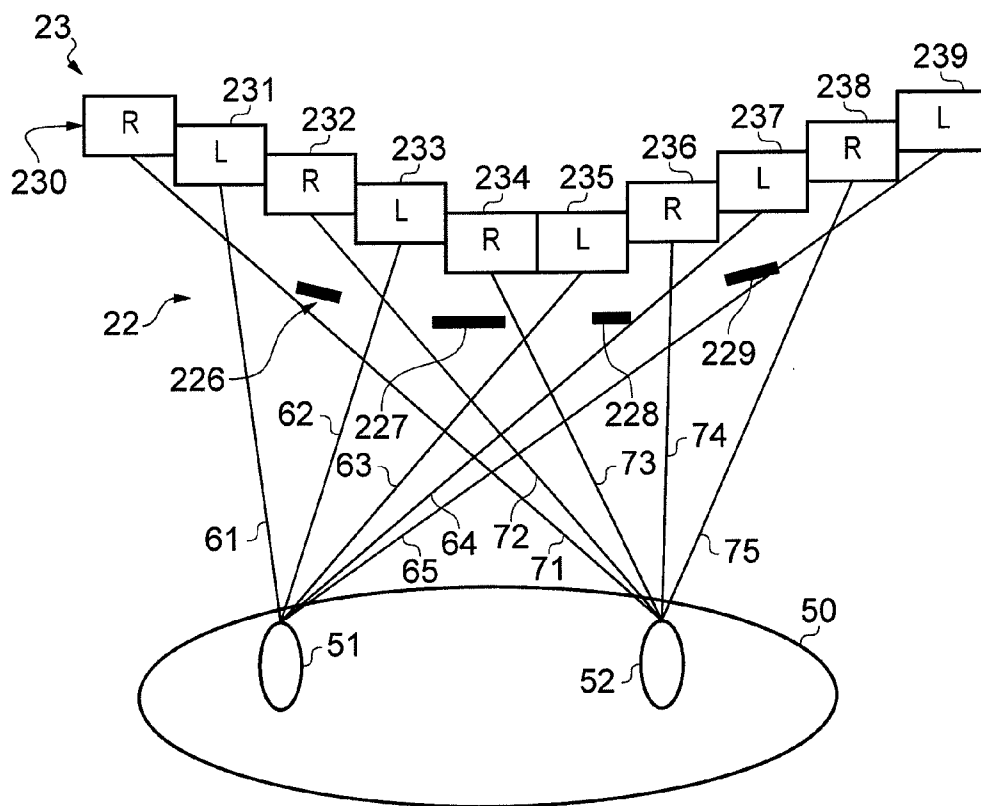

FIG. 5

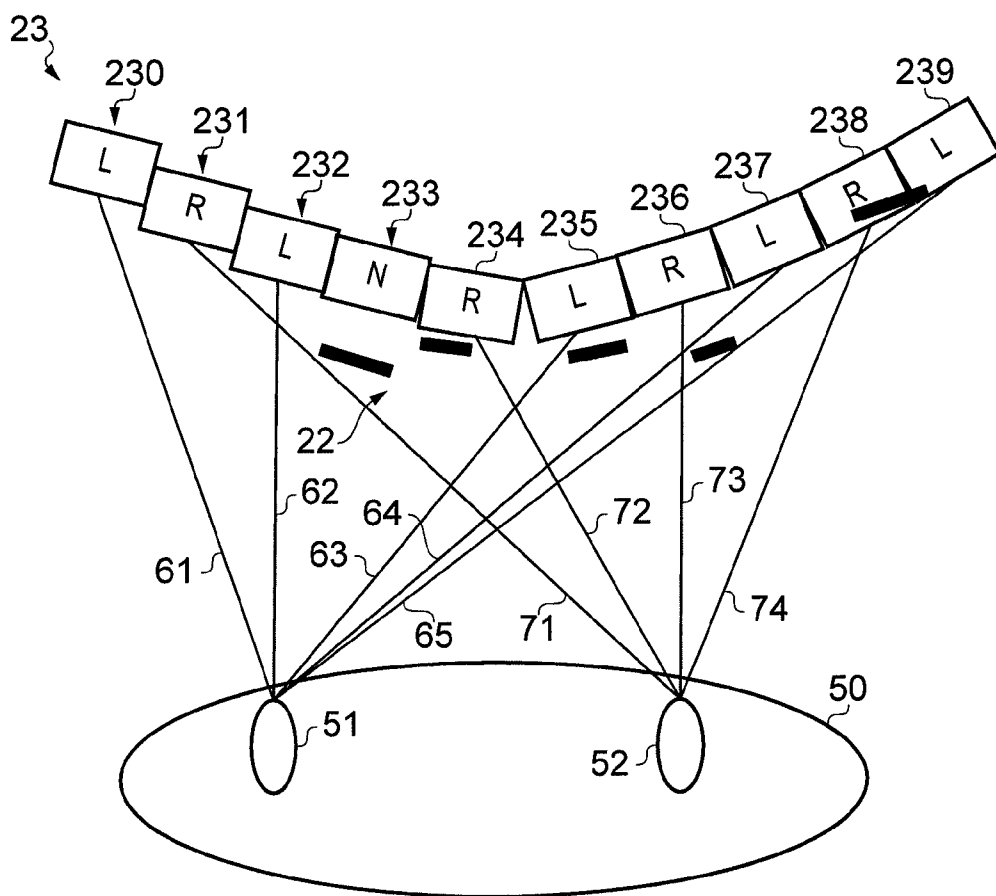

FIG. 6

AUTO-STEREOSCOPIC DISPLAY CONTROL

BRIEF DESCRIPTION

TECHNOLOGICAL FIELD

[0001] Embodiments of the present invention relate to auto-stereoscopic display control. In particular, they relate to controlling a parallax barrier arrangement of a flexible auto-stereoscopic display.

[0010] For a better understanding of various examples of embodiments of the present invention reference will now be made by way of example only to the accompanying drawings in which:

[0011] FIG. 1 illustrates an apparatus;

[0012] FIG. 2 illustrates a further apparatus;

[0013] FIG. 3 illustrates a method;

[0014] FIG. 4 schematically illustrates a viewer viewing a flexible auto-stereoscopic display that has been bent, where a parallax barrier arrangement of the flexible auto-stereoscopic display has not been adjusted;

[0015] FIG. 5 schematically illustrates a viewer viewing a flexible auto-stereoscopic display that has been bent and the parallax barrier arrangement has been adjusted; and

[0016] FIG. 6 schematically illustrates a change in how auto-stereoscopic content is displayed by the flexible auto-stereoscopic display in accordance with adjustment of the parallax barrier arrangement.

BACKGROUND

[0002] A stereoscopic display is configured to convey a stereoscopic image (that is, a three dimensional image) to a viewer. Some stereoscopic displays require a viewer to wear special glasses (such as polarized glasses or active shutter glasses) in order to obtain the stereoscopic effect.

[0003] An auto-stereoscopic display is configured to convey a stereoscopic image to a viewer without requiring the viewer to wear special glasses to view the displayed stereoscopic image.

[0004] Some forms of auto-stereoscopic display include a parallax barrier arrangement. The parallax barrier arrangement controls which parts of the display can be seen by each eye of the viewer from a particular position. Each eye sees a different image, which results in a stereoscopic effect for the viewer.

DETAILED DESCRIPTION

BRIEF SUMMARY

[0017] Embodiments of the invention relate to controlling a parallax barrier arrangement of a flexible auto-stereoscopic display. An image displayed on the flexible display may be viewable in three dimensions from one or more viewer positions (“sweet spots”). At all other viewer positions, the viewer may see a two-dimensional image displayed on the flexible display rather than a three-dimensional image.

[0005] According to various, but not necessarily all, embodiments of the invention there is provided an apparatus, comprising: at least one processor; and at least one memory storing computer program instructions configured, working with the at least one processor, to cause the apparatus to perform at least the following: detecting bending of a flexible auto-stereoscopic display; and adjusting a parallax barrier arrangement of the flexible auto-stereoscopic display in dependence upon the bending of the flexible auto-stereoscopic display.

[0018] In embodiments of the invention, if a user bends the flexible auto-stereoscopic display, the three-dimensional effect is advantageously maintained at one or more of the “sweet spots” by adjusting the parallax barrier arrangement of the flexible display.

[0006] According to various, but not necessarily all, embodiments of the invention there is provided a method, comprising: detecting bending of a flexible auto-stereoscopic display; and adjusting a parallax barrier arrangement of the flexible auto-stereoscopic display in dependence upon the bending of the flexible auto-stereoscopic display.

[0019] In this regard, the figures illustrate an apparatus 10/30, comprising: at least one processor 12; and at least one memory 14 storing computer program instructions 16 configured, working with the at least one processor 12, to cause the apparatus 10/30 to perform at least the following: detecting bending of a flexible auto-stereoscopic display 20; and adjusting a parallax barrier arrangement 22 of the flexible auto-stereoscopic display 20 in dependence upon the bending of the flexible auto-stereoscopic display 20.

[0007] According to various, but not necessarily all, embodiments of the invention there is provided an apparatus comprising means for performing the above method.

[0020] FIG. 1 illustrates a schematic of an apparatus 10 comprising at least one processor 12 and at least one memory 14. The apparatus 10 may, for example, be a chip or a chipset. Although a single processor 12 and a single memory 14 are illustrated in FIG. 1, in some implementations of the invention more than one processor 12 and/or more than one memory 14 is provided.

[0008] According to various, but not necessarily all, embodiments of the invention there is provided a non-transitory computer readable medium storing computer program instructions that, when performed by at least one processor, cause at least the following to be performed: detecting bending of a flexible auto-stereoscopic display; and adjusting a parallax barrier arrangement of the flexible auto-stereoscopic display in dependence upon the bending of the flexible auto-stereoscopic display.

[0021] The processor 12 is configured to read from and write to the memory 14. The processor 12 may also comprise an output interface via which data and/or commands are output by the processor 12 and an input interface via which data and/or commands are input to the processor 12.

[0009] According to various, but not necessarily all, embodiments of the invention there is provided an apparatus comprising: means for detecting bending of a flexible auto-stereoscopic display; and means for adjusting a parallax barrier arrangement of the flexible auto-stereoscopic display in dependence upon the bending of the flexible auto-stereoscopic display.

[0022] Although the memory 14 is illustrated as a single component it may be implemented as one or more separate components some or all of which may be integrated/removable and/or may provide permanent/semi-permanent/dynamic/cached storage.

[0023] The memory 14 stores computer program instructions 16 that control the operation of the apparatus 10 when loaded into the processor 12. The computer program instructions 16 provide the logic and routines that enables the appa-

ratus 10/30 to perform the method illustrated in FIG. 3. The processor 12 by reading the memory 14 is able to load and execute the computer program instructions 16.

[0024] The computer program instructions 16 may arrive at the apparatus 10/30 via any suitable delivery mechanism 40. The delivery mechanism 40 may be, for example, a non-transitory computer-readable storage medium, a computer program product, a memory device, a record medium such as a compact disc read-only memory (CD-ROM) or digital versatile disc (DVD), an article of manufacture that tangibly embodies the computer program instructions 16. The delivery mechanism 40 may be a signal configured to reliably transfer the computer program instructions 16. The apparatus 10/30 may propagate or transmit the computer program instructions 16 as a computer data signal.

[0025] FIG. 2 illustrates a schematic of a further apparatus 30. The apparatus 30 may, for example, be a hand-portable electronic apparatus. The apparatus 30 may be configured to operate as a mobile telephone, an electronic book, a tablet computer, a games console and/or a portable music player.

[0026] The apparatus 30 illustrated in FIG. 2 comprises a flexible auto-stereoscopic display 20, a user output device 11, one or more image sensors 13 and the apparatus 10 illustrated in FIG. 1. The elements 11, 12, 13, 14 and 20 are operationally coupled and any number or combination of intervening elements can exist (including no intervening elements). The elements 11, 12, 13, 14 and 20 may be co-located within a housing.

[0027] The user output device 11 may, for example, be an illumination apparatus comprising one or more light emitting diodes. The processor 12 is configured to provide control outputs to the user output device 11.

[0028] The processor 12 is also configured to read image data from the one or more image sensors 13. The one or more image sensors 13 may, for example, be charge coupled devices (CCDs) or complementary metal-oxide-semiconductor (CMOS) sensors.

[0029] The flexible auto-stereoscopic display 20 comprises one or more touch sensors 21, a parallax barrier arrangement 22, a (flexible) display panel 23 and one or more flex sensors 24.

[0030] The one or more touch sensors 21 are configured to sense touch input from a user (for example, fingertip or stylus input). The processor 12 is configured to read the touch sensor(s) 21. The touch sensor(s) 21 may be any type of touch sensors, including resistive sensors, capacitive sensors, infrared sensors or surface acoustic wave sensors, or some combination of these sensors.

[0031] The display panel 23 comprises a plurality of pixels arranged in columns and rows. The processor 12 is configured to control the display panel 23 to display stereoscopic images (that is, three dimensional images) and non-stereoscopic images (that is, two dimensional images).

[0032] The display panel 23 may be any type of flexible display panel. It could, for example, be a liquid crystal display panel (LCD), an organic light emitting diode (OLED) display panel, a quantum dot display panel or an electrophoretic ink (E Ink) display panel.

[0033] The one or more flex sensors 24 are configured to sense when the flexible display 20 is bent (for example by a user). The one or more flex sensors 24 may also sense the position(s) at which the flexible display 20 has been bent and the extent to which it has been bent. The processor 12 is configured to read the flex sensor(s) 24. The one or more flex

sensors 24 may, for example, comprise one or more strain gauges, one or more piezoelectric sensors, one or more optical sensors, one or more capacitive sensors and/or one or more resistive sensors.

[0034] The parallax barrier arrangement 22 is positioned between the display panel 23 and a viewer of the display panel 23. It is controlled by the processor 12. When the display 20 is in a stereoscopic (three-dimensional) mode, the processor 12 controls the parallax barrier arrangement 22 to provide a plurality of opaque regions that define a plurality of slits. In this mode, the parallax barrier arrangement 22 separates light emanating from the display panel 23 such that the viewer's left eye sees a different image to the viewer's right eye. Image content for viewer's left eye and image content for the viewer's right eye is displayed concurrently on the display panel 23.

[0035] When the display 20 is in a non-stereoscopic (two dimensional) mode, the processor 12 controls the parallax barrier arrangement 22 such that it does not separate out light emanating from the display panel 23 for the viewer's left and right eyes. For example, in this mode, the parallax barrier arrangement 22 may be transparent.

[0036] The parallax barrier arrangement 22 may comprise at least one parallax barrier. Each parallax barrier may, for example, comprise a switching liquid crystal that includes portions which switch from being substantially opaque to being substantially transparent.

[0037] A method according to embodiments of the invention will now be described with reference to FIG. 3.

[0038] Initially, the flexible auto-stereoscopic display 20 is in stereoscopic mode. A viewer is positioned in a position (a "sweet spot") that enables him to view the display 20 stereoscopically. At this time, the flexible display 20 is substantially planar in shape.

[0039] The viewer of the display 20 subsequently bends/flexes the display 20 using his hands, such that a cross-section of the flexible display 20 defines a curve. At block 300 of FIG. 3, the processor 12 detects bending of the flexible display 20 by reading the one or more flex sensors 24. The output provided by the flex sensors 24 to the processor 12 may, for example, indicate the position(s) at which the flexible display 20 has been bent and/or the magnitude/extent of the bending.

[0040] FIG. 4 is a schematic illustrating a viewer 50 viewing the flexible auto-stereoscopic display 20 following bending of the display 20, and without adjustment of the parallax barrier arrangement 22. A cross section of the display panel 23 comprising ten pixels 230-239 is shown for illustrative purposes. Each pixel 230-239 is positioned in a different column in the display panel 23. The pixels 230, 232, 234, 236 and 238 are displaying image content for viewer's right eye 52 and the pixels 231, 233, 235, 237 and 239 are displaying image content for the viewer's left eye 51. The illustrated parallax barrier arrangement 22 comprises a plurality of opaque regions 220-225 which define a plurality of slits.

[0041] Prior to the flexible display 20 being bent by the viewer 50, the viewer's left eye 51 was able to see pixels 231, 233, 235, 237 and 239 and the viewer's right eye 52 was able to see pixels 230, 232, 234, 236 and 238. The parallax barrier arrangement 22 prevented the viewer's left eye 51 from seeing pixels 230, 232, 234, 236 and 238 and prevented the viewer's right eye 52 from seeing pixels 231, 233, 235, 237 and 239, in order to provide a stereoscopic effect.

[0042] After the flexible display 20 was bent by the viewer 50 (as shown in FIG. 4), the viewer's left eye 51 is still able to

see pixels **231**, **233** and **235**, because light passing through those pixels reaches the viewer's left eye **51** (see light rays **61**, **62** and **63** in FIG. 4). However, the viewer **50** cannot see pixels **237** and **239**, because the light passing through those pixels is being blocked by the opaque regions **223** and **224** (see light rays **64** and **65** in FIG. 4). The viewer's right eye **52** is able to see pixels **232**, **234**, **236** and **238** (see light rays **72-75** in FIG. 4) but it cannot see pixel **230**, because light passing through that pixel is being blocked by the opaque region **221** (see light ray **71** in FIG. 4).

[0043] In some circumstances, it may also be the case that, due to the inappropriate positioning of the parallax barrier arrangement **22** following bending of the flexible display **20**, the viewer's right eye **52** can see image content that is being displayed for his left eye **51** and the viewer's left eye **51** can see image content that is being displayed for his right eye **52**.

[0044] The viewer **50** in FIG. 4 will either see a poorer quality stereoscopic image following bending of the flexible display **20**, or he will lose the stereoscopic effect altogether. However, in embodiments of the invention, this may be avoided. This is because, at block **301** of FIG. 3, the processor **12** adjusts the parallax barrier arrangement **22** in dependence upon the bending of the flexible display **20**.

[0045] The processor **12** may adjust at least one or more characteristics of the parallax barrier arrangement **22** following bending of the flexible display **20**. For example, the processor **12** may control the parallax barrier arrangement **22** to re-position the opaque regions and the slits in the parallax barrier arrangement **22**, such that different regions of the parallax barrier arrangement **22** are opaque following bending, as compared with the parallax barrier arrangement **22** prior to bending. Alternatively or additionally, the width of one or more of the opaque regions may be adjusted.

[0046] FIG. 5 illustrates an example of a situation in which the parallax barrier arrangement **22** of the flexible display **20** has been adjusted by the processor **12**. In the FIG. 5 example, the parallax barrier arrangement **22** comprises opaque regions **226**, **227**, **228** and **229**. The adjusted parallax barrier arrangement **22** enables the viewer's left eye **51** to see pixels **231**, **233**, **235**, **237** and **239** displaying left eye image content (see light rays **61-65** in FIG. 5) and enables the viewer's right eye **52** to see pixels **230**, **232**, **234**, **236** and **238** displaying right eye image content (see light rays **71-75** in FIG. 5).

[0047] The viewer's left eye **51** is prevented by the opaque regions **226-229** of the parallax barrier arrangement **22** from seeing the right eye image content being displayed by pixels **230**, **232**, **234**, **236** and **238**. The viewer's right eye **52** is prevented by the opaque regions **226-229** of the parallax barrier arrangement **22** from seeing the left eye image content being displayed by pixels **231**, **233**, **235**, **237** and **239**.

[0048] Adjustment of the parallax barrier arrangement **22** in accordance with bending of the flexible display **20** advantageously enables a (clear) stereoscopic image to continue to be conveyed to the viewer **50**. In some embodiments, there is no need for the viewer **50** to change his viewing position in order to continue viewing the stereoscopic image displayed by the flexible display **20** after the display **20** has been bent. For example, in some implementations, the processor **12** may assume that the viewer's viewing position has not changed when the flexible display **20** is bent and it may adjust the parallax barrier arrangement **22** accordingly.

[0049] In other implementations, the processor **12** may use the image sensor(s) **13** to determine the positions of the viewer's eyes **51**, **52**. The processor **12** may use this information to

determine how to adjust the parallax barrier arrangement **22**, when the flexible display **20** is bent, to enable a clear stereoscopic image to continue to be conveyed to the viewer **50**.

[0050] In some examples, the processor **12** may be configured to control the user output device **11** to cause an output to be provided to the viewer **50**, following bending of the flexible display **20**, which is associated with a switch from the display **20** displaying a stereoscopic image to the display **20** displaying a non-stereoscopic image. For example, if excessive bending of the display **20** has or is about to occur, the processor **12** may control the user output device **11** to provide a warning output to the viewer **50** (for example, by illuminating a warning light) after or prior to switching the flexible display **20** from displaying a stereoscopic image to displaying a non-stereoscopic image.

[0051] FIG. 6 illustrates an implementation in which the processor **12** responds to detecting bending of the flexible display **20** by changing how auto-stereoscopic content is displayed by the display panel **23**, in accordance with adjustment of the parallax barrier arrangement **22**. The processor **12** may, for example, change which pixels are viewable by one or both eyes **51**, **52** of the viewer **50**.

[0052] In this example, when the flexible display **20** is substantially planar, the processor **12** controls alternate columns of pixels of the display panel **23** to display left eye image content and right eye image content. Pixels **230**, **232**, **234**, **236** and **238** display left eye image content and pixels **231**, **233**, **235**, **237** and **239** display right eye image content.

[0053] When the parallax barrier arrangement **22** is adjusted in dependence upon the bending of the flexible display **20**, the processor **12** controls the display panel **23** such that pixel **233** is not used to display any image content. Both eyes **51**, **52** of the viewer **50** may be prevented from seeing pixel **233** by the adjusted parallax barrier arrangement **22**. Pixels **230**, **232**, **235**, **237** and **239** are controlled by the processor **12** to display left eye image content, and pixels **231**, **234**, **236** and **238** are controlled by the processor **12** to display right eye image content.

[0054] References to 'computer-readable storage medium', or a 'computer', 'processor', etc. should be understood to encompass not only computers having different architectures such as single/multi-processor architectures and sequential (Von Neumann)/parallel architectures but also specialized circuits such as field-programmable gate arrays (FPGAs), application specific circuits (ASICs), signal processing devices and other processing circuitry. References to computer program, instructions, code etc. should be understood to encompass software for a programmable processor or firmware such as, for example, the programmable content of a hardware device whether instructions for a processor, or configuration settings for a fixed-function device, gate array or programmable logic device, etc.

[0055] As used in this application, the term 'circuitry' refers to all of the following:

- (a) hardware-only circuit implementations (such as implementations in only analog and/or digital circuitry) and
- (b) to combinations of circuits and software (and/or firmware), such as (as applicable): (i) to a combination of processor(s) or (ii) to portions of processor(s)/software (including digital signal processor(s)), software, and memory(ies) that work together to cause an apparatus, such as a mobile phone or server, to perform various functions) and

(c) to circuits, such as a microprocessor(s) or a portion of a microprocessor(s), that require software or firmware for operation, even if the software or firmware is not physically present.

[0056] This definition of ‘circuitry’ applies to all uses of this term in this application, including in any claims. As a further example, as used in this application, the term “circuitry” would also cover an implementation of merely a processor (or multiple processors) or portion of a processor and its (or their) accompanying software and/or firmware. The term “circuitry” would also cover, for example and if applicable to the particular claim element, a baseband integrated circuit or applications processor integrated circuit for a mobile phone or a similar integrated circuit in server, a cellular network device, or other network device.

[0057] The blocks illustrated in FIG. 3 may represent steps in a method and/or sections of code in the computer program instructions 16. The illustration of a particular order to the blocks does not necessarily imply that there is a required or preferred order for the blocks and the order and arrangement of the block may be varied. Furthermore, it may be possible for some blocks to be omitted.

[0058] Although embodiments of the present invention have been described in the preceding paragraphs with reference to various examples, it should be appreciated that modifications to the examples given can be made without departing from the scope of the invention as claimed. For example, the user output device 11 could be an aural device rather than a visual device, such as a loudspeaker.

[0059] Features described in the preceding description may be used in combinations other than the combinations explicitly described.

[0060] Although functions have been described with reference to certain features, those functions may be performable by other features whether described or not.

[0061] Although features have been described with reference to certain embodiments, those features may also be present in other embodiments whether described or not.

[0062] Whilst endeavoring in the foregoing specification to draw attention to those features of the invention believed to be of particular importance it should be understood that the Applicant claims protection in respect of any patentable feature or combination of features hereinbefore referred to and/or shown in the drawings whether or not particular emphasis has been placed thereon.

I/We claim:

1. An apparatus, comprising:
at least one processor; and
at least one memory storing computer program instructions configured, working with the at least one processor, to cause the apparatus to perform at least the following:
detecting bending of a flexible auto-stereoscopic display;
and
adjusting a parallax barrier arrangement of the flexible auto-stereoscopic display in dependence upon the bending of the flexible auto-stereoscopic display.
2. An apparatus as claimed in claim 1, wherein adjustment of the parallax barrier arrangement depends upon where the flexible auto-stereoscopic display is bent.
3. An apparatus as claimed in claim 1, wherein adjustment of the parallax barrier arrangement depends upon the extent to which the flexible auto-stereoscopic display is bent.
4. An apparatus as claimed in claim 1, wherein the parallax barrier arrangement is configured to provide a plurality of

opaque regions defining a plurality of slits, and adjusting the parallax barrier arrangement comprises adjusting at least one characteristic of the opaque regions.

5. An apparatus as claimed in claim 4, wherein the at least one characteristic comprises one or more positions of the opaque regions.

6. An apparatus as claimed in claim 4, wherein the at least one characteristic comprises one or more widths of the opaque regions.

7. An apparatus as claimed in claim 1, wherein the positions of a viewer’s eyes are determined using at least one image captured by one or more image sensors, and the parallax barrier arrangement is adjusted in dependence upon the determined positions.

8. An apparatus as claimed in claim 1, wherein adjustment of the parallax barrier arrangement changes which pixels of the flexible auto-stereoscopic display are viewable by one or both eyes of a viewer.

9. An apparatus as claimed in claim 1, wherein the computer program instructions are configured, working with the at least one processor, to cause the apparatus to: change how auto-stereoscopic image content is displayed by pixels of the flexible auto-stereoscopic display, in accordance with adjustment of the parallax barrier arrangement.

10. An apparatus as claimed in claim 1, wherein the computer program instructions are configured, working with the at least one processor, to cause: an output to be provided to a viewer, following the bending of the flexible auto-stereoscopic display, which is associated with a switch from the flexible auto-stereoscopic display displaying a stereoscopic image to the flexible auto-stereoscopic display displaying a non-stereoscopic image.

11. An apparatus as claimed in claim 1, wherein the computer program instructions are configured, working with the at least one processor, to cause: the flexible auto-stereoscopic display to change from displaying a stereoscopic image to displaying a non-stereoscopic image, in dependence upon the bending of the flexible auto-stereoscopic display.

12. An apparatus as claimed in claim 1, further comprising the flexible auto-stereoscopic display which includes a display panel and the parallax barrier arrangement.

13. A method, comprising:

detecting bending of a flexible auto-stereoscopic display;
and

adjusting a parallax barrier arrangement of the flexible auto-stereoscopic display in dependence upon the bending of the flexible auto-stereoscopic display.

14. A method as claimed in claim 13, wherein the parallax barrier arrangement is configured to provide a plurality of opaque regions defining a plurality of slits, and adjusting the parallax barrier arrangement comprises adjusting at least one characteristic of the opaque regions.

15. A method as claimed in claim 13, wherein the at least one characteristic comprises one or more positions of the opaque regions and/or one or more widths of the opaque regions.

16. A method as claimed in claim 13, further comprising:
changing how auto-stereoscopic image content is displayed by pixels of the flexible auto-stereoscopic display, in accordance with adjustment of the parallax barrier arrangement.

17. A non-transitory computer readable medium storing computer program instructions that, when performed by at least one processor, cause at least the following to be performed:

- detecting bending of a flexible auto-stereoscopic display;
and
- adjusting a parallax barrier arrangement of the flexible auto-stereoscopic display in dependence upon the bending of the flexible auto-stereoscopic display.

18. A non-transitory computer readable medium as claimed in claim 17, wherein the parallax barrier arrangement is configured to provide a plurality of opaque regions defining

a plurality of slits, and adjusting the parallax barrier arrangement comprises adjusting at least one characteristic of the opaque regions.

19. A non-transitory computer readable medium as claimed in claim 17, wherein the at least one characteristic comprises one or more positions of the opaque regions and/or one or more widths of the opaque regions.

20. A non-transitory computer readable medium as claimed in claim 17, further comprising: changing how auto-stereoscopic image content is displayed by pixels of the flexible auto-stereoscopic display, in accordance with adjustment of the parallax barrier arrangement.

* * * * *