

[54] WASHING MACHINE AND DOOR LATCH

[57] ABSTRACT

[76] Inventor: Carl Ulrich, 244 Whitehall St.,
Lynbrook, N.Y. 11563

[22] Filed: Sept. 26, 1973

[21] Appl. No.: 400,799

[52] U.S. Cl. 292/336.3; 68/12 R

[51] Int. Cl. E05c 3/04

[58] Field of Search 292/DIG. 27, 336.3, 347

[56] References Cited

UNITED STATES PATENTS

1,855,697 4/1932 Sullivan 292/DIG. 27

Primary Examiner—Richard E. Moore

Attorney, Agent, or Firm—Pasquale A. Razzano;
Curtis, Morris & Safford

A safety door latch for a commercial washing machine is provided which is adapted to selectively maintain the door of the washing machine locked in its closed position during operation of the machine. The handle of the washing machine is rotatably mounted on the door and is connected to a latch member through a selectively operable clutch. The latch member cooperates with another latch member, fixed to the frame of the washing machine, so that when the latch members are in engagement the door is held in its closed position. In that position, the door latch member actuates means for disengaging the clutch so that rotation of the handle when the door is closed, and during operation of the machine, is ineffective to rotate the door latch member so that the door cannot be opened.

18 Claims, 10 Drawing Figures

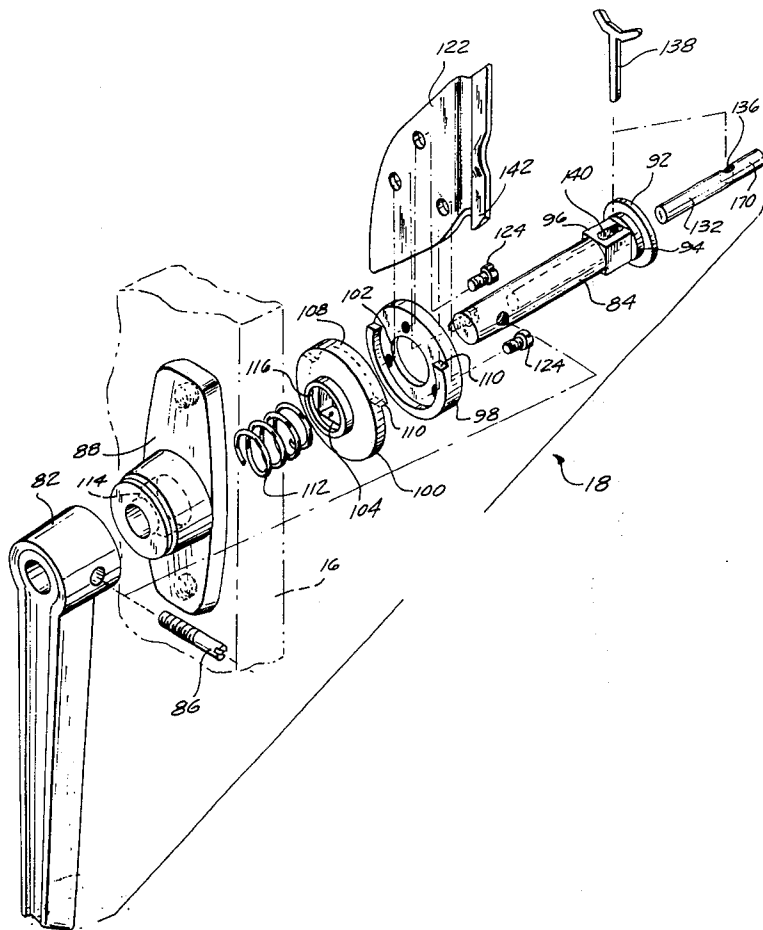

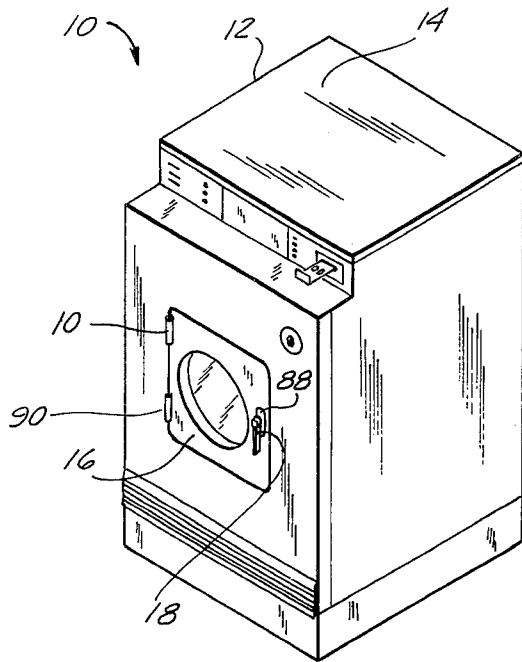

FIG. 1

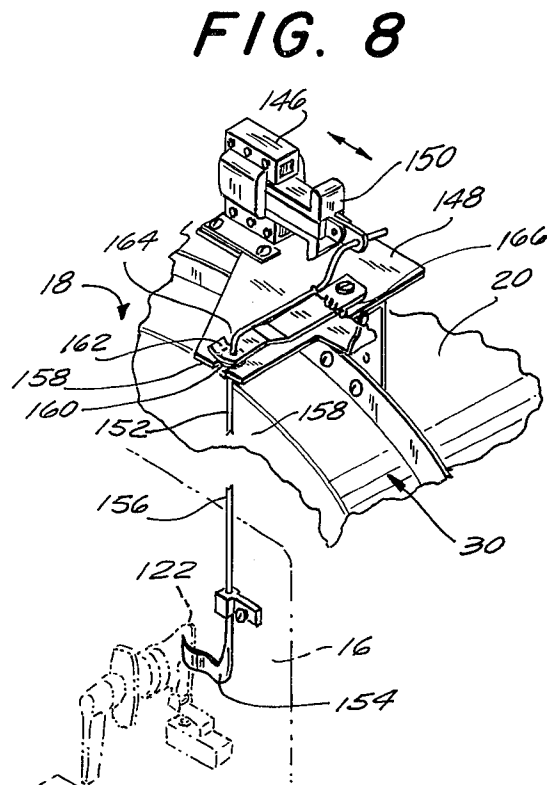

FIG. 8

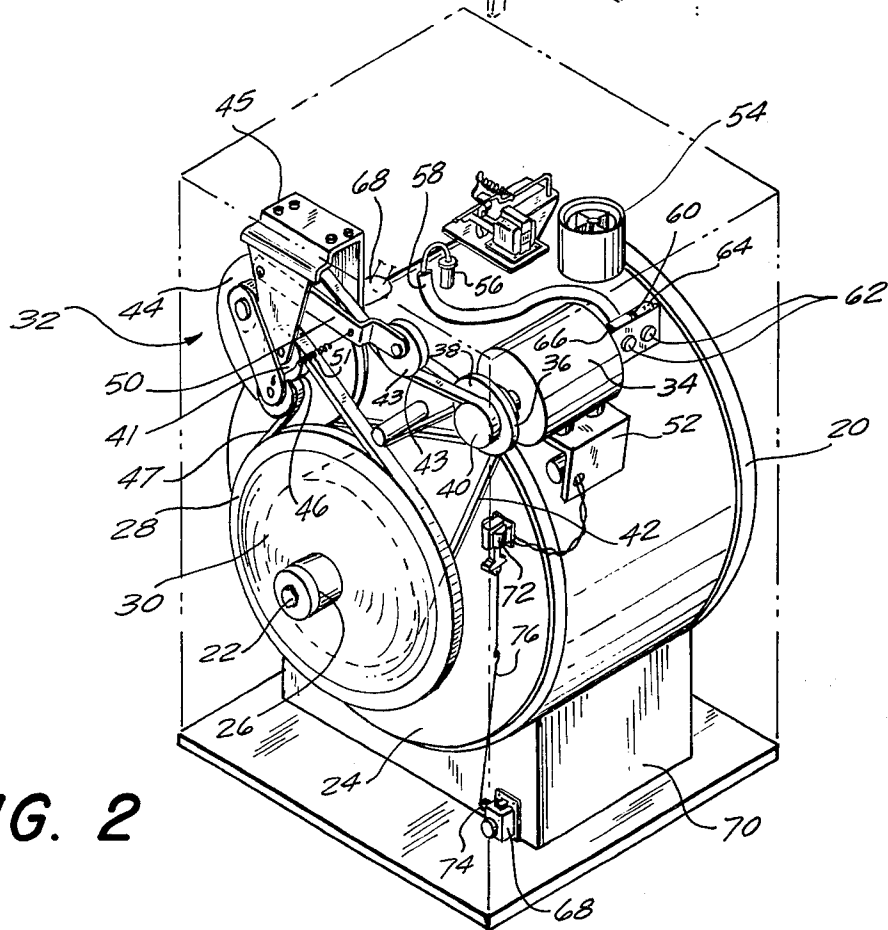

FIG. 2

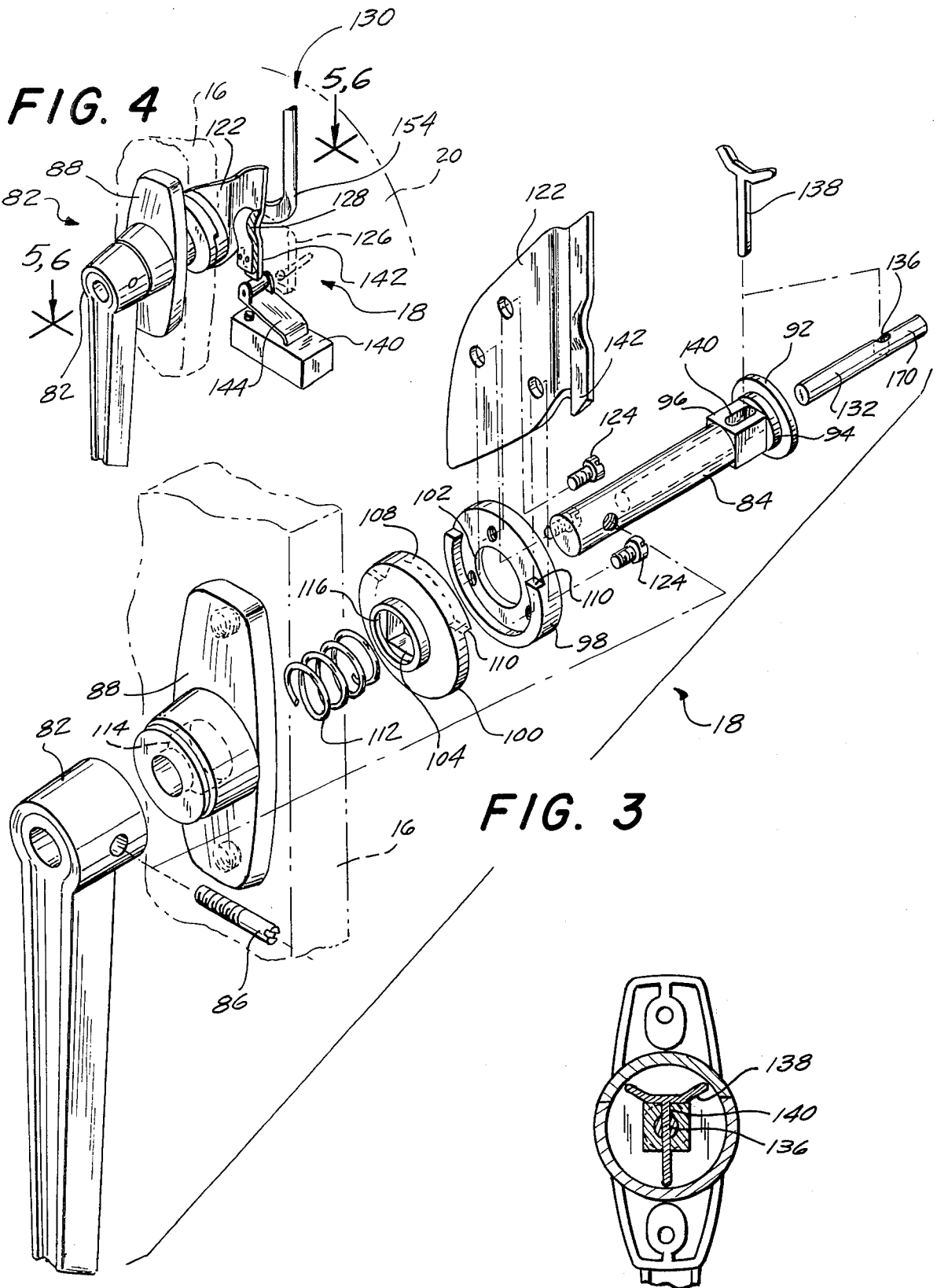

FIG. 4

FIG. 3

FIG. 7

FIG. 5

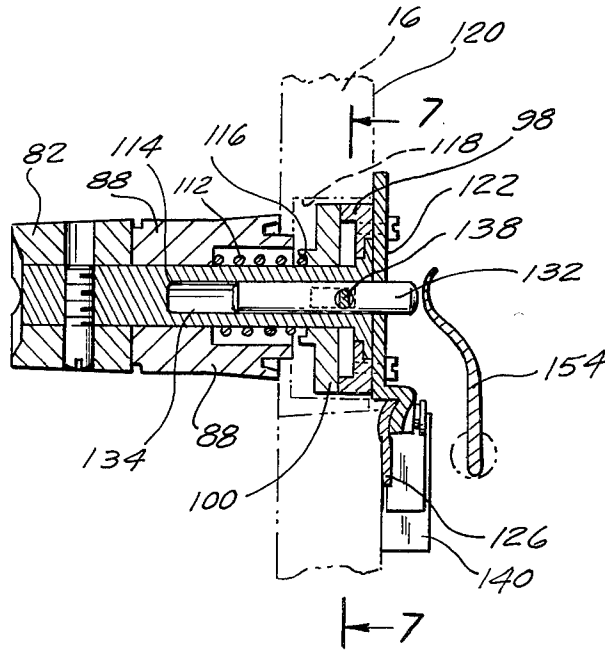
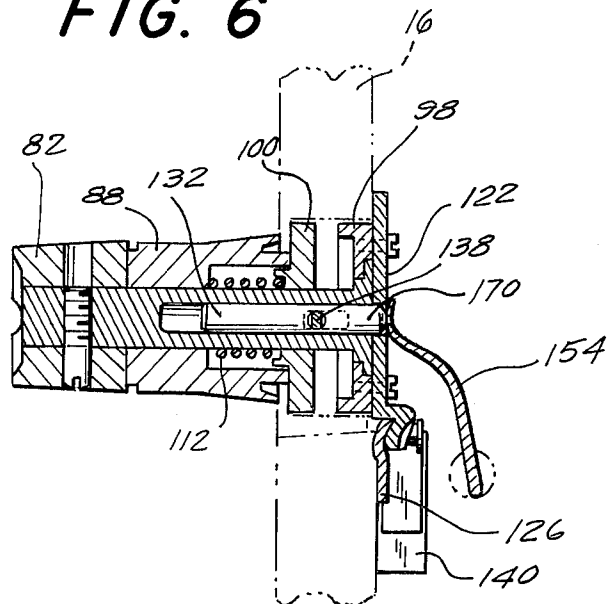

FIG. 6



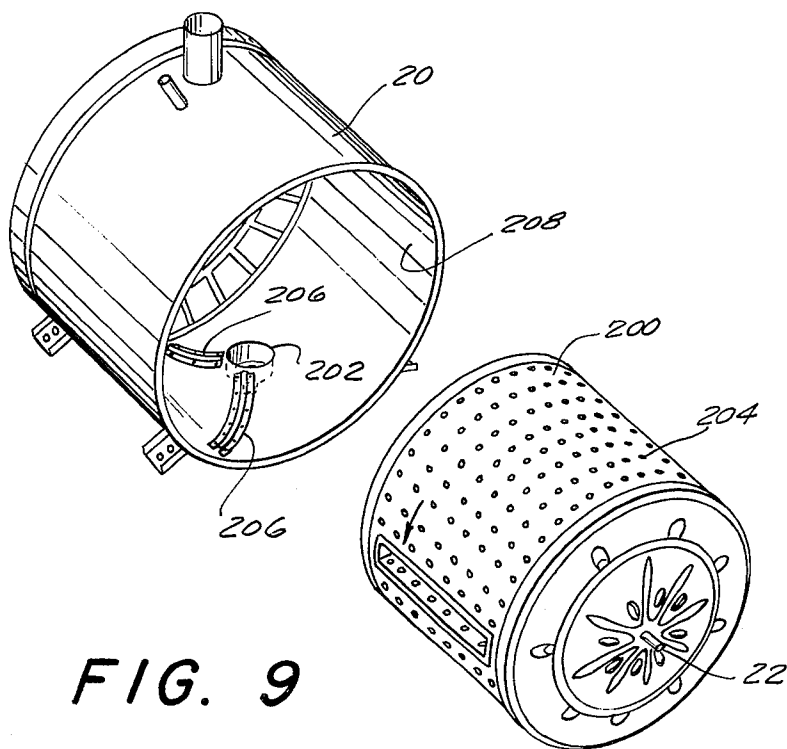

FIG. 9

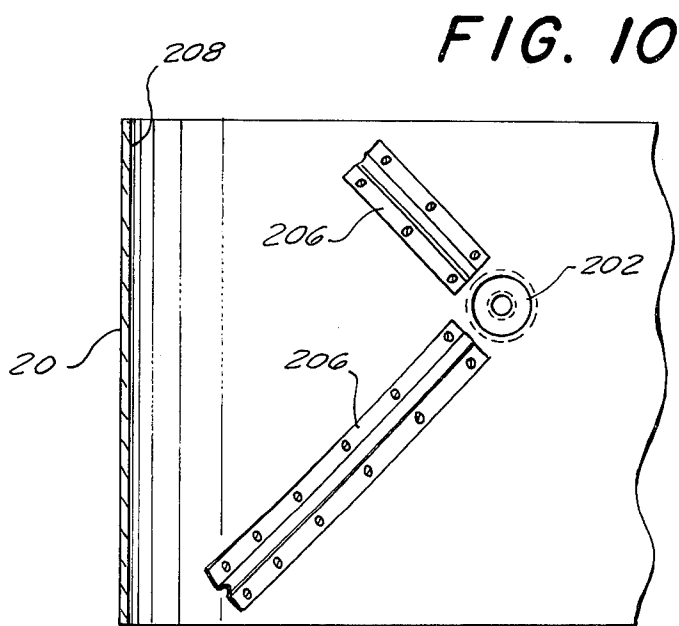

FIG. 10

WASHING MACHINE AND DOOR LATCH

The present invention relates to door latches and more particularly to a door latch for a commercial washing machine.

In recent years there has been a widespread increase in the number of commercial laundromat establishments at which the general public may launder clothing and other items in commercial washing machines. Many of these establishments use commercial washing machines which are coin operated and others use machines which are operated by the proprietor or by the public and for which a fee is paid directly to the proprietor. In either case, it is quite apparent that such commercial washing machines are subjected to intensive and substantially continuous use. As a result these machines are specially built to be quite durable and particularly adapted for heavy duty applications. However, it is still necessary from time to time to repair such machines as the various parts thereof wear during use.

Since such machines are used in commercial establishments the "down time" of these machines for repair purposes represents a loss of income to the proprietor of the laundromat. Accordingly, it is desirable that the machines be constructed in such a manner that repairs can be made rapidly and easily so that the machine can be placed back in operation immediately.

One problem with commercial washing machines is the inexperience of the person using the machines which result in overflow of water or suds from the machines. Such overflows often cause damage to the various operating mechanisms in the machine, particularly the electrical components thereof, thereby increasing the need for repairs.

Another problem with such machines is that the inexperienced operator will often attempt to open the door of the machine while it is in the wash or spin dry cycle. Accordingly, it has been found desirable to provide locks on these machines which do not permit the door of the machine to be opened during the operating cycle. However, previously proposed locks for this purpose are often damaged by the users of the machines since the user often attempts to force the lock to open the machine because they are unaware that the operating cycle is not yet completed or because they wish to interrupt the operating cycle and are under the mistaken impression that opening the door will do so.

Accordingly, it is an object of the present invention to provide a door latch mechanism for commercial washing machines which is durable in construction.

Yet another object of the present invention is to provide a door latch mechanism for a commercial washing machine which will prevent the door from being opened and the latch from being jammed or broken during the operating cycle.

Yet another object of the present invention is to provide a commercial washing machine which has its various operating components in a conveniently accessible location for permitting rapid repairs.

In accordance with an aspect of the present invention a commercial washing machine is provided in which substantially all of the operating mechanisms and control components therefore are located at the top of the machine in order to provide easy access through the top for repairs to such apparatus and components. The machine is also provided with a latch mechanism which will keep the door of the washing machine closed dur-

ing the operating cycle and which will prevent the user from jamming or breaking the latch. This latch mechanism includes a pair of cooperating latch members, one of which is mounted on the interior frame of the washing machine and the other of which is rotatably mounted on the door of the machine. The latter latch member is secured to the external handle on the door through a clutch mechanism which is normally engaged so that rotation of the handle will cause rotation of the latch. However, when the door is closed, and the door latch member is engaged with the latch member secured to the washing machine frame, the door latch member engages a switch which operates a solenoid controlled clutch disengagement mechanism. This mechanism disengages the elements of the clutch so that further rotation of the handle will not effect rotation of the latch mechanism. As a result, the handle is free to rotate when turned by a user; thus the handle and latch mechanism cannot be jammed and the door cannot be opened. The clutch disengaging mechanism remains actuated throughout the entire operating cycle of the machine and when that cycle is completed, as determined by the timing mechanism controlling the machine, the clutch disengaging mechanism is deactivated so that the latch can be rotated upon operation of the handle.

The above, and other objects, features and advantages of the present invention will be apparent from the following detailed description of an illustrative embodiment thereof which is to be read in connection with the accompanying drawings wherein:

FIG. 1 is a perspective view of a commercial washing machine constructed in accordance with the present invention;

FIG. 2 is a perspective view from the rear of the interior mechanism of the washing machine of FIG. 1;

FIG. 3 is an exploded perspective view of a portion of the latch mechanism used to lock the door of the washing machine of the present invention;

FIG. 4 is a perspective view of the handle and latch mechanism in the closed position of the door;

FIG. 5 is a sectional view, taken in plan, along line 5-5 of FIG. 4, of the latch mechanism of the present invention in the operating position of the clutch mechanism;

FIG. 6 is a sectional view similar to FIG. 5 showing the configuration of the clutch mechanism when the washing machine is in operation;

FIG. 7 is a sectional view, taken along line 7-7 of FIG. 5;

FIG. 8 is a perspective view of the entire latch assembly and clutch disengaging mechanism;

FIG. 9 is an exploded perspective view of the drum assembly of the washing machine of the present invention; and

FIG. 10 is a partial plan view of the water drain guide structure on the interior of the drum assembly.

Referring now to the drawing in detail and initially to FIG. 1 thereof, it will be seen that a washing machine 10, constructed in accordance with the present invention, includes an external housing 12 having a top 14 which is pivotally mounted along its rear edge in any convenient manner so that the top may be open to expose the interior of the machine for repair purposes as described more fully hereinafter. Housing 12 also includes a front door 16 which provides access to the interior drum of the washing machine, which door is pro-

vided with a lock or latch mechanism 18, constructed in accordance with the present invention and which is adapted to lock door 16 in its closed position during operation of the machine.

Washing machine 10 includes, as seen in FIG. 2, an internal drum-shaped rigid frame 20 which contains a rotatably mounted drum 200 (see FIG. 8) in which the clothing and other items are placed, through door 16, for the washing process. This rotatably drum includes a shaft 22 rotatably mounted in frame 20 in any convenient manner which extends through the rear wall 24 of the frame. Shaft 22 is operatively connected through a spring clutch mechanism 26 of conventional construction to a pair of pulleys 28, 30 respectively. These pulleys are drivingly connected through a transmission system 32 to an electric motor 34. The latter includes a centrifugal clutch 36 drivingly connected to a pair of output sheaves 38, 40.

Inner output sheave 38 is connected directly to the pulley 30 by a belt 42 of transmission system 32 for high speed rotation of the drum. On the other hand output sheave 40 is connected through a belt 43 in transmission system 32 to jack shaft sheave 44. The latter is rotatably mounted in a subassembly 45 on frame 20 and is drivingly connected to a coaxial output sheave 46 of smaller diameter. The latter is drivingly connected to the large diameter drive sheaves 28 by a belt 47 for low speed rotation of the drum. Belts 42, 47 are maintained in their proper tension by a pair of pivotally mounted idler arms 48, 50 respectively which are spring biased towards each other by a tension spring 41.

By this construction, at low speed operations centrifugal clutch 36 causes the sheave 40 to be operated, thereby to drive the drum through the outer sheave 28. At higher speed operations, i.e. at higher speeds of rotation of motor 34, centrifugal clutch 36, operating in the conventional manner, causes sheave 38 to rotate in lieu of sheave 40 so that a direct high speed drive through sheave 30 is permitted. Spring clutch 26 provides for a smooth transition between the operating speeds.

As seen most clearly in FIG. 2, motor 34 is mounted at the upper surface of frame 20, through an L-shaped bracket 52. Accordingly, the motor is above the base of the washing machine and is thereby protected against damage due to overflow or flooding in the base of the machine as a result of improper operation thereof by the user.

Frame 20 includes a vent 54 which permits discharge of heated and moist air from the interior and normally perforated rotating drum to the atmosphere. On the other hand, water is supplied to the interior frame 20, and thus to the rotating drum within the washing machine, through an inlet vent opening 56. The water is supplied through this opening from a hose 58 which is connected through a valve mechanism to a pair of inlet ports 62 through which hot and cold water are supplied from separate supply hoses (not shown). Valve mechanism 60 includes solenoid valves 64, 66 which are controlled by the electrical operating control system of the machine to permit the operator to select the proper proportion of hot and cold water which are supplied through the valve mechanism to hose 58 and thus to the interior drum.

The electronic controls for the solenoid valves 64, 66 and for the other aspects of the machine of the present

invention are of conventional construction and would be understood by those skilled in the art. All of the controls, including the conventional switching control mechanism 68 (such as is provided in the commercially available DUPLEX washing machine) are located on the upper portion of frame 20 away from the base of the machine. Accordingly, all of the electrical controls are protected against possible damage due to flooding and overflow of the machine during operation.

Discharge of water from the drum within the machine is provided through a dump valve 68 located at the base 70 of frame 20. This base receives water from the perforated drum 200 (shown in FIG. 8) inside of the frame 20 through drain 202, and this water is discharged through valve 68 to a hose (not shown) connected to the valve in any convenient manner. The valve itself is controlled through a solenoid 72 connected to the electrical control system of the machine. The solenoid is connected to the operating arm 74 of the dump valve 68 through a linkage 76. In this manner, the solenoid control member 72 is also located above the base, away from possible damage due to water in the base as a result of overflowing.

By this construction of the invention, it is seen that all of the operating mechanisms of the washing machine are located at the top of the washer so that they are freely available for repair and servicing through the top of the machine. As a result, the machine is more rapidly serviced by the repairman and less frequent repairs are required since the possibility of water damage to the various components is eliminated. It is noted that in previously proposed washing machines, for example the Duplex type washing machine mentioned above, the various controls, motors, etc. are located in the base of the machine, where access is difficult and where the controls and equipment are exposed to water damage.

In accordance with another aspect of the present invention, the frame 20 is provided with a water guide structure which improves water drainage into the base of frame 20 for discharge through the dump valve 68. As mentioned above, frame 20 includes a drain 202 through which water from the perforated rotatably mounted drum 200 is discharged. The drum 200 rotates in a single direction during operation of the washing machine, as indicated by the arrow 204 in FIG. 8, so that the water is discharged from the drum in a generally counterclockwise direction when the drum is viewed from the rear. In the typical washing machine structures, this water is simply sprayed through the perforations 201 in drum 200 into the exterior frame of drum 200 and gravitates to the central discharge opening 202. Applicant, however, has provided a guide structure which includes a pair of guide vanes 206 (more clearly shown in FIG. 9) which captures the water in the drum 200 and directs it to the drain opening 202. These guide vanes 206 comprise a pair of inverted generally U-shaped channels having a central raised portion whose height is approximately equal to the distance between the interior wall 208 of frame 20 and the periphery of drum 200. The guide channels are arranged in a generally V-shaped pattern, as seen in FIG. 9, so that during operation of the washing machine, water discharged through the perforations 201 in a counterclockwise path of travel, as discussed above, flows along the wall of drum 200 and is intercepted by the guides 206 and directed by them directly

to the drain hole 202. Thus, water discharged from drum 200 into frame 20 cannot pass beyond the guides 206 but must flow into the drain hole 202. This structure provides for more rapid discharge of water from the washing machine during the washing cycle. In addition, it limits the amount of water sprayed about in the frame 20, and thus substantially prevents any water from re-entering the drum 200 through the perforations therein, as may happen with previously proposed washing machines. Accordingly, a substantially improved drainage system is provided by the structure of the present invention.

In accordance with another aspect of the present invention, the washing machine is provided with the latching mechanism 18 (see FIGS. 4 and 8) which serves to lock the door 16 in a closed position during the operating cycle of the machine. The latching mechanism includes a handle 82 for use by the operator of the machine in opening and closing door 16. Handle 82 is rigidly mounted on a shaft 84 by means of a bolt 86, as seen in FIG. 3, which extends through the handle 82 into shaft 84. The latter is rotatably mounted in a boss 88 secured in any convenient manner to the exterior surface of door 16. The door is pivotally mounted on the housing 12 by hinges 90, in the conventional manner, so that the operator can open and close the door in order to expose the interior rotating drum of the machine for the purpose of placing clothing and the like therein.

Shaft 84 includes an inner end portion 92 having an outer annular section 94 and a square section 96 formed inwardly thereof. These sections 94, 96 of the shaft 84 provide mounting support for a pair of clutch plates 98, 100 respectively. Clutch plate 98 has an inner annular opening 102 which receives the annular portion 94 of shaft 84, so that the clutch plate 98 is rotatable with respect to the shaft. On the other hand, clutch plate 100 has a square opening 104 formed therein which receives the square portion 96 of shaft 84. The clutch faces have opposed complementary wall members 106, 108 formed therein, with the ends 110 of the respective wall members being located so as to engage each other when the clutch plates are in mating engagement, thereby to drivingly interconnect the two clutch plates.

Clutch plate 100 is normally biased into engagement with clutch plate 98 by a spring 112 which surrounds the shank of shaft 84 and is in engagement between an inner surface 114 of boss 88 and the rear surface 116 of clutch plate 100. By this arrangement, the two clutch plates are normally maintained in engagement with each other.

As seen in FIG. 4, in the assembled configuration of the latch mechanism, the clutch plates are received in a recess 118 in the inside surface 120 of door 16.

A first latch member 122 is operatively connected to clutch plate 98 by a plurality of screws 124. This latch member or plate cooperates with a second latch plate 126 which is rigidly mounted on frame 20 of the washing machine, adjacent the opening therein (not seen) which provides access to the interior rotating drum within the frame. Latch plate 126 is positioned to engage plate 222 when door 16 is closed and the handle 82 is rotated into the position shown in FIG. 4. In this connection, latch plates 122, 126 have cooperating and mating convex surfaces 128 formed therein to define the closed latched position of the latch mechanism.

Because of the normal engagement between the clutch plates 98, 100 due to the bias of spring 112 when door 16 is open, rotation of handle 82 will cause rotation of shaft 84, and both clutch plates, thereby also causing rotation of latch plate 122. Accordingly, when the door 16 is closed, handle 82 may be rotated to position the latch plate 122 behind latch plate 126 with the convex surfaces thereof in mating engagement. In this configuration, the door cannot be pulled open unless handle 82 is rotated. However, latch mechanism 18 is provided with a clutch disengaging mechanism 130 which disengages clutch plates 98, 100 when the door is closed and the washing machine is operating.

Clutch disengaging mechanism 130 cooperates with a pin 132 which is slidably mounted in an axial recess 134 in shaft 84, which pin extends outwardly of the end 92 of shaft 84. Pin 132 has a transverse opening 136 formed therein which receives a clutch push member 138. The latter, as seen most clearly in FIGS. 3 and 7 is formed in the general configuration of a Y, with the stem portion thereof extending through opening 136 and an elongated slot 140 in the square portion 96 of shaft 84.

In the assembled configuration of the latch mechanism, clutch push member 138 is located between the clutch plates 98, 100, as seen in FIGS. 5 and 6, in the area between the clutch plates contained within the walls 106, 108 thereof (see FIG. 7). By this arrangement, axial movement of the pin 132 inwardly of shaft 84 causes the push member 138 to engage clutch plate 100, against the bias of spring 112, and to move that clutch plate away from clutch plate 98, thereby to disengage the clutch plates. Upon such disengagement, rotation of handle 82 will cause rotation of shaft 84, due to the rigid connection therebetween, however the clutch plate 98 and the latch plate 122 will not move because they will be held in a fixed position by the engagement of latch plates 122, 126. Accordingly, handle 82 will be free to rotate without effecting the latching engagement of the latch plates. The Y-shaped configuration of member 138 provides a stable three-point engagement of the clutch plate to insure even and uniform movement thereof.

Inward movement of pin 132 in this manner is controlled by a switch 140 mounted on frame 20 adjacent latch 126 in position to be engaged by the edge 142 of the latch member 122 when the latter is in its latched position shown in FIG. 4. Thus, when door 16 is closed and the latch plates 122, 126 engaged as described above, the actuating lever 144 of switch 140 is depressed.

Switch 146 controls the clutch disengaging mechanism 130 which in turn controls a solenoid 146 mounted on a plate 148 at the upper surface of frame 20. Solenoid 146 includes a plunger 150 which is operatively connected in any convenient manner to an L-shaped lever 152. The latter is pivotally mounted in the support plate 148 and includes a spoon or foot 154 which is located along the front surface of frame 20, opposite the pin 132 when the door 16 is closed.

Lever 152 includes an extension portion 156 which extends downwardly along the front surface 158 of frame 20 through a slot 158 in the front of plate 148. The lever is held in its relative vertical position by the provision of a ring 160 integrally formed on leg 156 and captured between plate 148 and an auxiliary plate 162 having a notch 164 therein which receives the leg 156

and overlies ring 160. In this manner, lever 152 is held in its relative vertical position, but is free to pivot about its vertical axis, thereby moving shoe or foot 154 towards and away from pin 132. Normally, lever 152 is biased by a spring 166 connected between the lever and plate 148 so that foot 154 is held remote from pin 152 (FIG. 5) and so that plunger 150 of solenoid 146 is held out of the housing of the solenoid.

In accordance with the present invention, when switch 140 is actuated upon closing of door 16 in the manner described above and when the machine is placed in operation to initiate the wash cycle, solenoid 146 is actuated to retract plunger 150 against the bias of spring 166. This causes rotation of the lever 152 and moves the foot 154 into engagement with the free end 170 of pin 132 (FIG. 6). This movement of foot 154 urges pin 132 into recess 134 thereby causing push member 138 to move clutch plate 100 away from clutch plate 98. Accordingly, door 16 is locked since latch plate 122 cannot be rotated upon further rotation of handle 82. Thus, the handle can be moved and rotated by a person using the machine, but will not cause the door 16 to be opened or the latch to be jammed.

Solenoid plunger 150 remains retracted in this configuration, so that door 16 remains locked, as long as the machine is in its operating cycle. Thus, the solenoid is controlled by two signals, i.e. the signal from the switch 140 and a signal from the operating controls of the washing machine. The exact electrical connection between the various components, is not described herein in detail since on the basis of the functional description thereof it is believed that such an electrical control circuit would be apparent to those skilled in the art.

In any case, upon the completion of the operating cycle, solenoid 146 is deactivated so that plunger 150 returns to its extended position under the influence of spring 166, thereby retracting foot 154 of the lever away from pin 132 in the shaft 84. As a result, spring 112 moves clutch plate 100 back into engagement with clutch plate 98. Thus, the operator of the machine can then rotate handle 82 and thus effect rotation of clutch plate 98 and the latching plate 122 secured thereto to open door 16.

Accordingly, it is seen that a relatively simply constructed latching mechanism is provided which serves to positively lock the door of a washing machine during the operating cycle of the machine. Because the handle is free to rotate during the operating cycle it is not possible for the user to inadvertently or even purposely break or jam the latching mechanism. In addition, it is also impossible for the user to open the door unless the operating cycle of the machine is completed either in accordance with its normal timing cycle or by the operator purposely advancing the timing cycle to completion, by properly adjusting the various control mechanisms on the washing machine. Moreover, because of the construction of the present invention, all of the operating mechanisms and electrical controls for the washing machine are located in the upper portion of the machine for easy access through the top opening in the machine housing. Accordingly, the machine is relatively easily repaired and serviced, and the various components are not subjected to water damage in the event of overflows in the machine.

Although an illustrative embodiment of the present invention has been described herein with reference to

the accompanying drawings, it is to be understood that the invention is not limited to that precise embodiment and that various changes and modifications may be effected therein by one skilled in the art without departing from the scope or spirit of this invention.

What is claimed is:

1. A safety door latch for selectively maintaining a door in a closed position with respect to a fixed frame comprising, a handle rotatably mounted on said door, a first latch member mounted on said frame adjacent said handle, a second latch member adapted to engage and cooperate with said first latch member, selectively operable and normally engaged clutch means for operatively connecting said second latch member to said handle for rotation with said handle when said clutch is engaged, whereby when said door is closed rotation of said handle places said second latch member in latching engagement with said first latch member; and means for selectively disengaging said clutch when said first and second latching members are in latching engagement whereby further rotation of said handle is ineffective to rotate said second latch member and said door is held in its closed position; said handle including a shaft rigidly connected thereto for rotation therewith; and said clutch means including a pair of clutch plates, one of said clutch plates being mounted on said shaft for rotation therewith and the other of said clutch plates being freely rotatably mounted on said shaft, said second latching member being secured to said other clutch plate whereby when said clutch plates are in operative engagement, rotation of said handle rotates said second latching member and when said clutch plates are disengaged, said handle and shaft rotate freely with respect to said second latching member.

2. The safety door latch as defined in claim 1 including means for normally biasing said clutch plates into engagement with each other.

3. The safety door latch as defined in claim 2 wherein said clutch disengaging means comprises means for urging said one clutch plate away from said other clutch plate against the bias of said spring biasing means.

4. The safety door latch as defined in claim 3 wherein said shaft has an elongated slot formed therein and said urging means includes a pin slidably mounted axially in said shaft and extending outwardly therefrom towards said frame; and a push member mounted in said pin and extending through said slot between said clutch plates for moving said one clutch plate away from said other clutch plate upon inward movement of said pin against the bias of said biasing means.

5. The safety door latch as defined in claim 4 wherein said push member has a generally Y-shaped configuration whereby said one clutch plate is in a stable three point engagement with said push member during movement thereof.

6. The safety door latch as defined in claim 4 wherein said clutch plates each include cooperating peripheral wall members adapted to drivingly engage each other, said push member being received in said one clutch plate within the confines of its peripheral wall.

7. The safety door latch as defined in claim 4 wherein said clutch disengaging means includes engaging and moving said pin inwardly of said shaft against the bias of said biasing means.

8. The safety door latch as defined in claim 7 wherein said clutch disengaging means further includes switch

means mounted on said frame adjacent said first latch member for engagement and actuation by said second latch member when said latch members are in mating engagement; and a solenoid operatively engaged with said pin engaging and moving means, said solenoid activating said pin engaging and moving means upon actuation of said switch.

9. The safety door latch as defined in claim 8 wherein said pin engaging and moving means comprises a lever pivotally mounted on said frame having one end connected to said solenoid and its other end located adjacent said pin.

10. The safety door latch as defined in claim 9 including spring means normally biasing said other end of said lever away from said pin.

11. A safety door latch for selectively maintaining a door in a closed position with respect to a fixed frame comprising, a handle rotatably mounted on said door, a first latch member mounted on said frame adjacent said handle, a second latch member adapted to engage and cooperate with said first latch member, selectively operable and normally engaged clutch means for operatively connecting said second latch member to said handle for rotation with said handle when said clutch is engaged, whereby when said door is closed rotation of said handle places said second latch member in latching engagement with said first latch member; and means for selectively disengaging said clutch when said first and second latching members are in latching engagement whereby further rotation of said handle is ineffective to rotate said second latch member and said door is held in its closed position; said clutch engaging means including means for detecting the latching engagement of said first and second latching members which comprises switch means positioned adjacent said one latch member for engagement by said other latch member when the latter is rotated into latching engagement with said first latch member.

12. The safety door latch as defined in claim 11 wherein said clutch disengaging means includes a solenoid operatively connected to said switch for actuation thereby upon engagement of said switch by said other latch member, said solenoid being operatively engaged with said clutch for disengaging the clutch when actuated by said switch.

13. The safety door latch as defined in claim 11 in-

cluding timing means for deactivating said solenoid after a predetermined time period.

14. The safety door latch as defined in claim 13 wherein said door and frame form portions of a clothes washing machine and said predetermined time period comprises the completion of the wash cycle of said machine.

15. The safety door latch as defined in claim 1 wherein said latch is used on the door of a commercial clothes washing machine, said machine including a drum rotatably mounted in said frame, drive means for said drum mounted on the top of said frame, and water supply means for said drum mounted on the top of said frame.

16. The device as defined in claim 15 including electrical control means for controlling the operation of said washing machine and said clutch disengaging means, said electrical control means being mounted on the top of said frame.

17. The device as defined in claim 15 wherein said frame has a water drain hole therein and a pair of water drain vanes mounted in said frame adjacent said drain hole in a generally V-shaped configuration whose apex is located adjacent said hole and in the direction of rotation of said drum.

18. A safety door latch for selectively maintaining a door in a closed position with respect to a fixed frame comprising, a handle rotatably mounted on said door, a first latch member mounted on said frame adjacent said handle, a second latch member adapted to engage and cooperate with said first latch member, selectively operable and normally engaged clutch means for operatively connecting said second latch member to said handle for rotation with said handle when said clutch is engaged, whereby when said door is closed rotation of said handle places said second latch member in latching engagement with said first latch member; means for detecting the latching engagement of said first and second latching members upon said rotation of said handle; and means, responsive to said detecting means, for disengaging said clutch when said first and second latching members are rotated into latching engagement, whereby further rotation of said handle is ineffective to rotate said second latch member and said door is held in its closed position.

* * * * *

50

55

60

65