



US007294897B2

(12) **United States Patent**
Akram et al.

(10) **Patent No.:** **US 7,294,897 B2**
(45) **Date of Patent:** **Nov. 13, 2007**

(54) **PACKAGED MICROELECTRONIC IMAGERS AND METHODS OF PACKAGING MICROELECTRONIC IMAGERS**

5,505,804 A 4/1996 Mizuguchi et al.
5,593,913 A 1/1997 Aoki

(Continued)

(75) Inventors: **Salman Akram**, Boise, ID (US);
Charles M. Watkins, Eagle, ID (US);
Kyle K. Kirby, Boise, ID (US); **Alan G. Wood**, Boise, ID (US); **William M. Hiatt**, Eagle, ID (US)

FOREIGN PATENT DOCUMENTS

EP 0 886 323 12/1998

(Continued)

OTHER PUBLICATIONS

H. Kurino et al., Intelligent Image Sensor Chip with Three Dimensional Structure, Dec. 5-8, 1999, IEDM Technical Digest. International Electron Devices Meeting, pp. 879-882.*

(Continued)

Primary Examiner—Howard Weiss
Assistant Examiner—John Ingham
(74) *Attorney, Agent, or Firm*—Dickstein Shapiro LLP

(73) Assignee: **Micron Technology, Inc.**, Boise, ID (US)

(*) Notice: Subject to any disclaimer, the term of this patent is extended or adjusted under 35 U.S.C. 154(b) by 7 days.

(21) Appl. No.: **10/879,398**

(22) Filed: **Jun. 29, 2004**

(57) **ABSTRACT**

(65) **Prior Publication Data**

US 2005/0285154 A1 Dec. 29, 2005

(51) **Int. Cl.**
H01L 31/203 (2006.01)

(52) **U.S. Cl.** **257/434; 257/234; 257/E33.07; 438/69**

(58) **Field of Classification Search** **257/434, 257/234, E33.07; 438/69**

See application file for complete search history.

(56) **References Cited**

U.S. PATENT DOCUMENTS

3,345,134 A 10/1967 Heymer et al.
4,534,100 A 8/1985 Lane
4,906,314 A 3/1990 Farnworth et al.
5,130,783 A 7/1992 McLellan
5,371,397 A 12/1994 Maegawa et al.
5,424,573 A 6/1995 Kato et al.
5,435,887 A 7/1995 Rothschild et al.

Microelectronic imagers, methods for packaging microelectronic imagers, and methods for forming electrically conductive through-wafer interconnects in microelectronic imagers are disclosed herein. In one embodiment, a microelectronic imaging die can include a microelectronic substrate, an integrated circuit, and an image sensor electrically coupled to the integrated circuit. A bond-pad is carried by the substrate and electrically coupled to the integrated circuit. An electrically conductive through-wafer interconnect extends through the substrate and is in contact with the bond-pad. The interconnect can include a passage extending completely through the substrate and the bond-pad, a dielectric liner deposited into the passage and in contact with the substrate, first and second conductive layers deposited onto at least a portion of the dielectric liner, and a conductive fill material deposited into the passage over at least a portion of the second conductive layer and electrically coupled to the bond-pad.

26 Claims, 9 Drawing Sheets

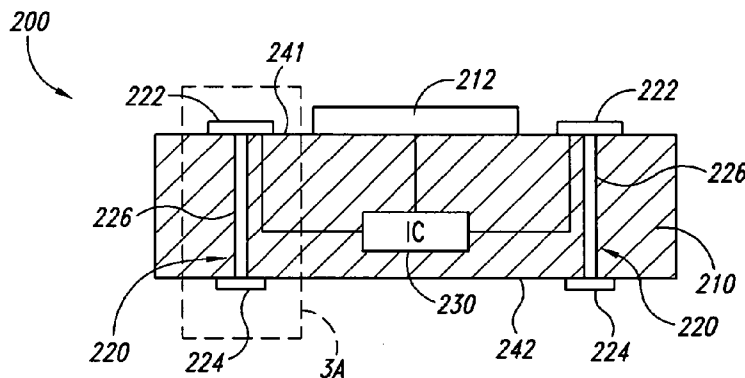

U.S. PATENT DOCUMENTS

5,605,783 A 2/1997 Revelli et al.
 5,672,519 A 9/1997 Song et al.
 5,694,246 A 12/1997 Aoyama et al.
 5,708,293 A 1/1998 Ochi et al.
 5,771,158 A 6/1998 Yamagishi et al.
 5,776,824 A 7/1998 Farnworth et al.
 5,811,799 A 9/1998 Wu
 5,821,532 A 10/1998 Beaman et al.
 5,857,963 A 1/1999 Pelchy et al.
 5,861,654 A 1/1999 Johnson
 5,877,040 A 3/1999 Park et al.
 5,897,338 A 4/1999 Kaldenberg
 5,914,488 A 6/1999 Sone
 5,977,535 A 11/1999 Rostoker
 5,998,862 A 12/1999 Yamanaka
 6,080,291 A 6/2000 Woodruff et al.
 6,104,086 A 8/2000 Ichikawa et al.
 6,114,240 A 9/2000 Akram et al.
 6,143,588 A 11/2000 Glenn
 6,235,554 B1* 5/2001 Akram et al. 438/109
 6,236,046 B1 5/2001 Watabe et al.
 6,259,083 B1 7/2001 Kimura
 6,266,197 B1 7/2001 Glenn et al.
 6,274,927 B1 8/2001 Glenn
 6,285,064 B1 9/2001 Foster
 6,351,027 B1 2/2002 Giboney et al.
 6,372,548 B2 4/2002 Bessho et al.
 6,407,381 B1 6/2002 Glenn et al.
 6,411,439 B2 6/2002 Nishikawa
 6,483,652 B2 11/2002 Nakamura
 6,503,780 B1 1/2003 Glenn et al.
 6,534,863 B2 3/2003 Walker et al.
 6,541,762 B2 4/2003 Knag et al.
 6,560,047 B2 5/2003 Choi et al.
 6,566,745 B1 5/2003 Beyne et al.
 6,603,183 B1 8/2003 Hoffman
 6,617,623 B2 9/2003 Rhodes
 6,661,047 B2 12/2003 Rhodes
 6,667,551 B2 12/2003 Hanaoka et al.
 6,670,986 B1 12/2003 Ben Shoshan et al.
 6,686,588 B1 2/2004 Webster et al.
 6,703,310 B2 3/2004 Mashino et al.
 6,703,689 B2* 3/2004 Wada 257/621
 6,864,172 B2 4/2004 Noma et al.
 6,734,419 B1 5/2004 Glenn et al.
 6,759,266 B1 7/2004 Hoffman
 6,774,486 B2 8/2004 Kinsman
 6,778,046 B2 8/2004 Stafford et al.
 6,791,076 B2 9/2004 Webster
 6,795,120 B2 9/2004 Takagi et al.
 6,797,616 B2 9/2004 Kinsman
 6,800,943 B2 10/2004 Adachi
 6,813,154 B2 11/2004 Diaz et al.
 6,825,458 B1 11/2004 Moess et al.
 6,828,663 B2 12/2004 Chen et al.
 6,828,674 B2 12/2004 Karpman
 6,844,978 B2 1/2005 Harden et al.
 6,882,021 B2 4/2005 Boon et al.
 6,885,107 B2 4/2005 Kinsman
 6,934,065 B2 8/2005 Kinsman
 6,946,325 B2 9/2005 Yean et al.
 2002/0006687 A1 1/2002 Lam
 2002/0019069 A1* 2/2002 Wada 438/69
 2002/0057468 A1 5/2002 Segawa et al.
 2002/0089025 A1 7/2002 Chou
 2002/0096729 A1 7/2002 Tu et al.
 2002/0113296 A1 8/2002 Cho et al.
 2002/0145676 A1 10/2002 Kuno et al.
 2003/0062601 A1 4/2003 Harnden et al.
 2004/0012698 A1 1/2004 Suda et al.
 2004/0023469 A1 2/2004 Suda

2004/0038442 A1 2/2004 Kinsman
 2004/0041261 A1 3/2004 Kinsman
 2004/0082094 A1 4/2004 Yamamoto
 2004/0214373 A1 10/2004 Jiang et al.
 2004/0245649 A1 12/2004 Imaoka
 2005/0029643 A1* 2/2005 Koyanagi 257/680
 2005/0052751 A1 3/2005 Liu et al.
 2005/0104228 A1 5/2005 Rigg et al.
 2005/0110889 A1 5/2005 Tuttle et al.
 2005/0127478 A1 6/2005 Hiatt et al.
 2005/0151228 A1 7/2005 Tanida et al.
 2005/0236708 A1 10/2005 Farnworth et al.
 2005/0254133 A1 11/2005 Akram et al.
 2005/0275048 A1* 12/2005 Farnworth et al. 257/431

FOREIGN PATENT DOCUMENTS

EP 1 157 967 11/2001
 FR 2 835 654 A1 8/2003
 JP 59-101882 A 6/1984
 JP 59-191388 10/1984
 JP 07-263607 A 10/1995
 JP 2001-077496 A 3/2001
 WO WO-90/05424 A1 5/1990
 WO WO-02/075815 A1 9/2002
 WO WO-02/095796 A2 11/2002
 WO WO-2004/054001 A2 6/2004

OTHER PUBLICATIONS

International Search Report and Written Opinion for PCT/US2004/037415, mailed Jul. 5, 2005.
 U.S. Appl. No. 10/785,466, Kirby.
 U.S. Appl. No. 10/845,304, Jiang et al.
 U.S. Appl. No. 10/857,948, Boettiger et al.
 U.S. Appl. No. 10/863,994, Akram et al.
 U.S. Appl. No. 10/864,974, Kirby et al.
 U.S. Appl. No. 10/867,352, Farnworth et al.
 U.S. Appl. No. 10/867,505, Farnworth et al.
 U.S. Appl. No. 10/879,838, Kirby et al.
 U.S. Appl. No. 10/893,022, Hall et al.
 U.S. Appl. No. 10/894,262, Farnworth et al.
 U.S. Appl. No. 10/901,851, Derderian et al.
 U.S. Appl. No. 10/910,491, Boiken et al.
 U.S. Appl. No. 10/915,180, Street et al.
 U.S. Appl. No. 10/919,604, Farnworth et al.
 U.S. Appl. No. 10/922,177, Oliver et al.
 U.S. Appl. No. 10/922,192, Farnworth.
 U.S. Appl. No. 10/925,406, Oliver.
 U.S. Appl. No. 10/925,501, Oliver.
 U.S. Appl. No. 10/925,502, Watkins et al.
 U.S. Appl. No. 10/927,550, Derderian et al.
 U.S. Appl. No. 10/927,760, Chong et al.
 U.S. Appl. No. 10/928,598, Kirby.
 U.S. Appl. No. 10/932,296, Oliver et al.
 U.S. Appl. No. 11/027,443, Kirby.
 U.S. Appl. No. 11/054,692, Boemler.
 U.S. Appl. No. 11/056,211, Hembree et al.
 U.S. Appl. No. 11/056,484, Boettiger et al.
 U.S. Appl. No. 11/061,034, Boettiger.
 U.S. Appl. No. 11/146,783, Tuttle et al.
 U.S. Appl. No. 11/169,546, Sulfridge.
 U.S. Appl. No. 11/169,838, Sulfridge.
 U.S. Appl. No. 11/177,905, Akram.
 U.S. Appl. No. 11/209,524, Akram.
 U.S. Appl. No. 11/217,169, Hiatt et al.
 U.S. Appl. No. 11/217,877, Oliver et al.
 U.S. Appl. No. 11/218,126, Farnworth et al.
 U.S. Appl. No. 11/218,243, Kirby et al.
 Aachboun, S. and P. Ranson, "Cryogenic etching of deep narrow trenches in silicon," J. Vac. Sci. Technol. A 18(4), Jul./Aug. 2000, pp. 1848-1852.
 Aachboun, S. and P. Ranson, "Deep anisotropic etching of silicon," J. Vac. Sci. Technol. A 17(4), Jul./Aug. 1999, pp. 2270-2273.

- Austin, M.D. and S.Y. Chou, "Fabrication of 70 nm channel length polymer organic thin-film transistors using nanoimprint lithography," *Applied Physics Letters*, vol. 81, No. 23, pp. 4431-4433, Dec. 2, 2002, American Institute of Physics.
- Blackburn, J.M. et al., "Deposition of Conformal Copper and Nickel Films from Supercritical Carbon Dioxide," *Science*, vol. 294, pp. 141-145, Oct. 5, 2001.
- Brubaker, C. et al., "Ultra-thick Lithography for Advanced Packaging and MEMS," SPIE's 27th Annual International Symposium on Microlithography 2002, Mar. 3-8, 2002, Santa Clara, CA.
- Cheng, Yu-T. et al., "Vacuum Packaging Technology Using Localized Aluminum/Silicon-to-Glass Bonding," *Journal of Microelectromechanical Systems*, vol. 11, No. 5, pp. 556-565, Oct. 2002.
- DuPont Electronic Materials, Data Sheet, Pyralux PC 2000 Flexible Composites, 4 pages, Oct. 1998, <<http://www.dupont.com/fcm>>.
- Edmund Industrial Optics, Mounted IR Filters, 1 page, retrieved from the Internet on Jun. 30, 2003, <<http://www.edmundoptics.com>>.
- Hamdorf, M. et al., "Surface-rheological measurements on glass forming polymers based on the surface tension driven decay of imprinted corrugation gratings," *Journal of Chemical Physics*, vol. 112, No. 9, pp. 4262-4270, Mar. 1, 2000, American Institute of Physics.
- Hirafune, S. et al., "Packaging Technology for Imager Using Through-hole Interconnection in Si Substrate," *Proceeding of HDP'04*, IEEE, pp. 303-306, Jul. 2004.
- IBM, Zurich Research Laboratory, EPON SU-8 photoresist, 1 page, retrieved from the Internet on Jan. 21, 2003, <<http://www.zurich.ibm.com/st/mems/su8.html>>.
- Intrinsic Viscosity and Its Relation to Intrinsic Conductivity, 9 pages, retrieved from the Internet on Oct. 30, 2003, <<http://www.ciks.cbt.nist.gov/~garbocz/paper58/node3.html>>.
- King, B. et al., Optomec, Inc., M3D™ Technology, Maskless Mesoscale™ Materials Deposition, 5 pages, <<http://www.optomec.com/downloads/M3D%20White%Paper%20080502.pdf>>, retrieved from the Internet on Jun. 17, 2005.
- Kingpak Technology, Inc. "CMOS Image Sensor Packaging," 1 page, retrieved from the Internet on Aug. 26, 2003, <<http://www.kingpak.com/CMOSImager.html>>.
- Kramer, S.J. et al., "Annual Report—Applications of Supercritical Fluid Technology to Semiconductor Device Processing," pp. 1-29, Nov. 2001.
- Kyocera Corporation, Memory Package, 1 page, retrieved from the Internet on Dec. 3, 2004, <http://global.kyocera.com/prdct/semicon/ic_pkg/memory_p.html>.
- Lin, Tim (Zhigang) and Rick Yoon, "One Package Technique of Exposed MEMS Sensors," pp. 105-108, 2002 International Symposium on Microelectronics, Sep. 2002.
- Ma, X. et al., "Low Temperature Bonding for Wafer Scale Packaging and Assembly of Micromachined Sensors," Final Report 1998-1999 for MICRO Project 98-144, 3 pages, Department of Electrical & Computer Engineering, University of California, Davis.
- Micro Chem, Nano SU-8, Negative Tone Photoresist Formulations 50-100, 4 pages, Feb. 2002, <http://www.microchem.com/products/pdf/SU8_50-100.pdf>.
- Optomec, Inc., M3D™ Technology, Maskless Mesoscale Materials Deposition (M3D), 1 page, <<http://www.optomec.com/html/m3d.htm>>, retrieved from the Internet on Aug. 15, 2003.
- Optomec, Inc., M3D™, Maskless Mesoscale™ Materials Deposition, 2 pages, <<http://www.optomec.com/downloads/M3DSheet.pdf>>, retrieved from the Internet on Jun. 17, 2005.
- Photo Vision Systems, Inc., "Advances in Digital Image Sensors," 22 pages, First Annual New York State Conference on Microelectronic Design, Jan. 12, 2002.
- Shen, X.-J. et al., "Microplastic embossing process: experimental and theoretical characterizations," *Sensors and Actuators, A* 97-98 (2002) pp. 428-433, Elsevier Science B.V.
- Tapes II International Tape and Fabrication Company, Electronics and Electrical Tapes, 2 pages, 2003, <<http://www.tapes2.com/electronics.htm>>.
- TransChip, 1 page, retrieved from the Internet on Aug. 26, 2003, <<http://www.missionventures.com/portfolio/companies/transchip.html>>.
- TransChip, Inc., CMOS vs CCD, 3 pages, retrieved from the Internet on Dec. 14, 2005, <<http://www.transchip.com/content.aspx?id=127>>.
- TransChip, Inc., Technology, 3 pages, retrieved from the Internet on Dec. 14, 2005, <<http://www.transchip.com/content.aspx?id=10>>.
- UCI Integrated Nanosystems Research Facility, "Cleaning procedures for glass substrates," 3 pages, Fall 1999.
- UCI Integrated Nanosystems Research Facility, "Glass Etch Wet Process," 3 pages, Summer 2000.
- Walker, M.J., "Comparison of Bosch and cryogenic processes for patterning high aspect ratio features in silicon," 11 pages, *Proc. SPIE* vol. 4407, p. 89-99, MEMS Design, Fabrication, Characterization, and Packaging, Uwe F. Behringer; Deepak G. Uttamchandani; Eds., Apr. 2001.
- Xsil, Via Applications, 1 page, <<http://www.xsil.com/viaapplications/index.htm>>, retrieved from the Internet on Jul. 22, 2003.
- Xsil, Vias for 3D Packaging, 1 page, <<http://www.xsil.com/viaapplications/3dpackaging/index.htm>>, retrieved from the Internet on Jul. 22, 2003.
- Ye, X.R. et al., "Immersion Deposition of Metal Films on Silicon and Germanium Substrates in Supercritical Carbon Dioxide," *Chem. Mater.* 2003, 15, 83-91.
- Yoshida, J. "TransChip rolls out a single-chip CMOS imager," 3 pages, *EE Times*, Jul. 18, 2003.

* cited by examiner

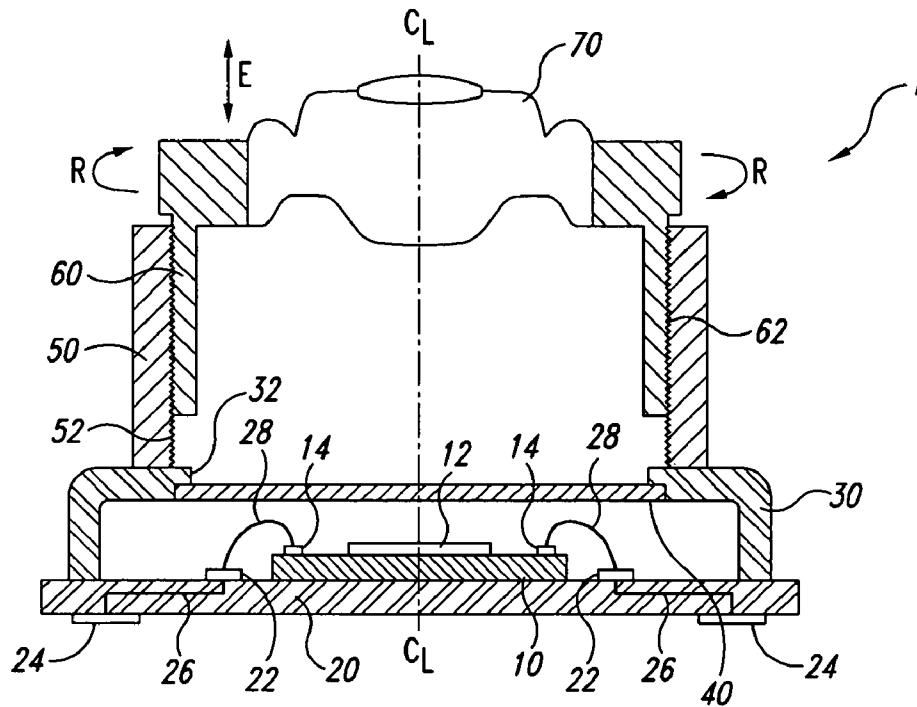

Fig. 1
(Prior Art)

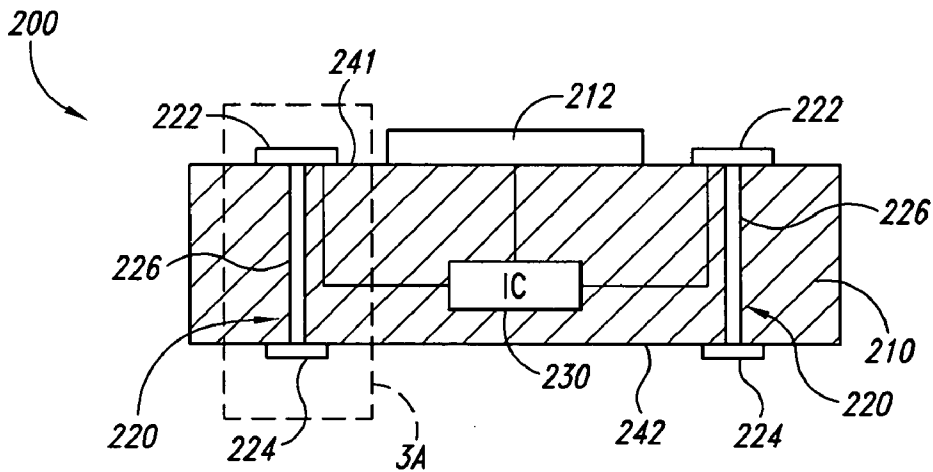

Fig. 2

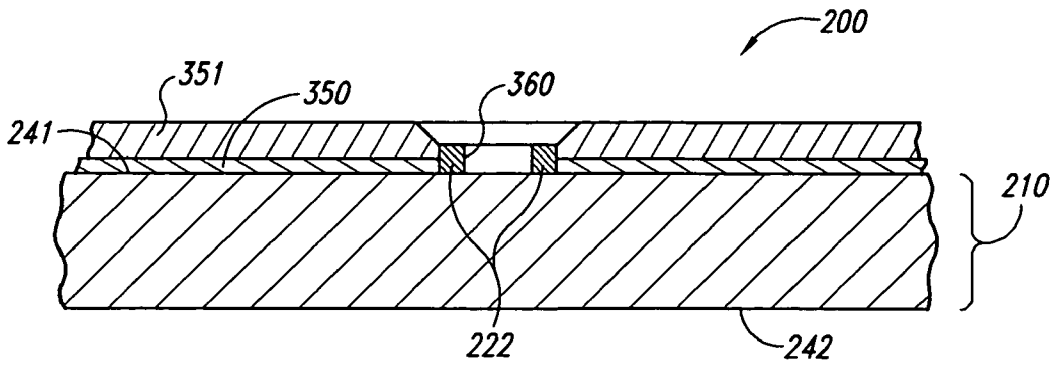

Fig. 3A

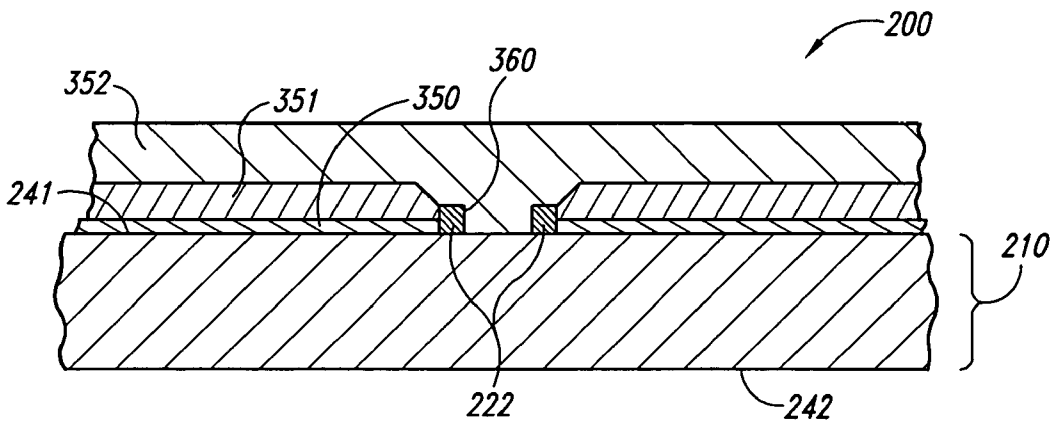

Fig. 3B

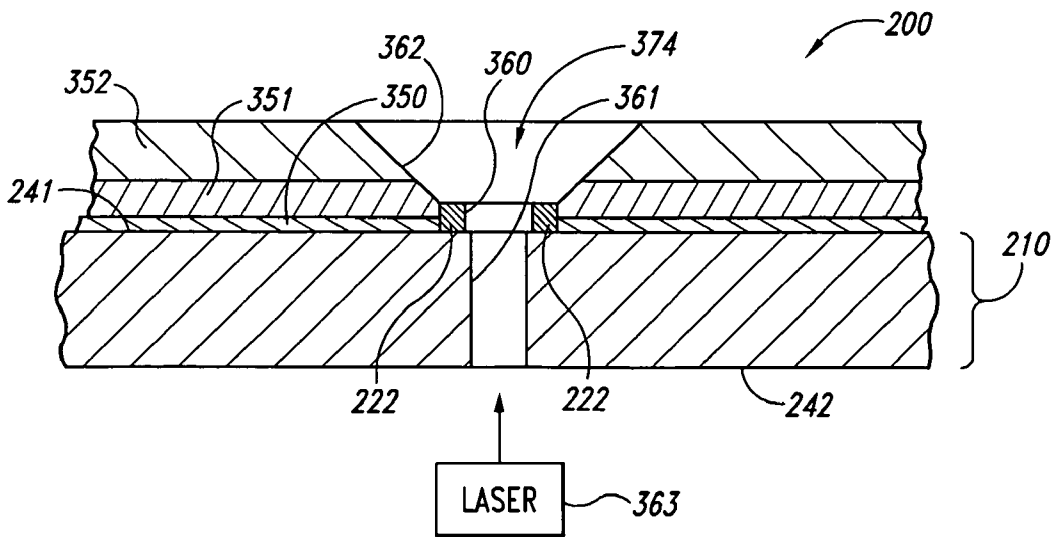

Fig. 3C

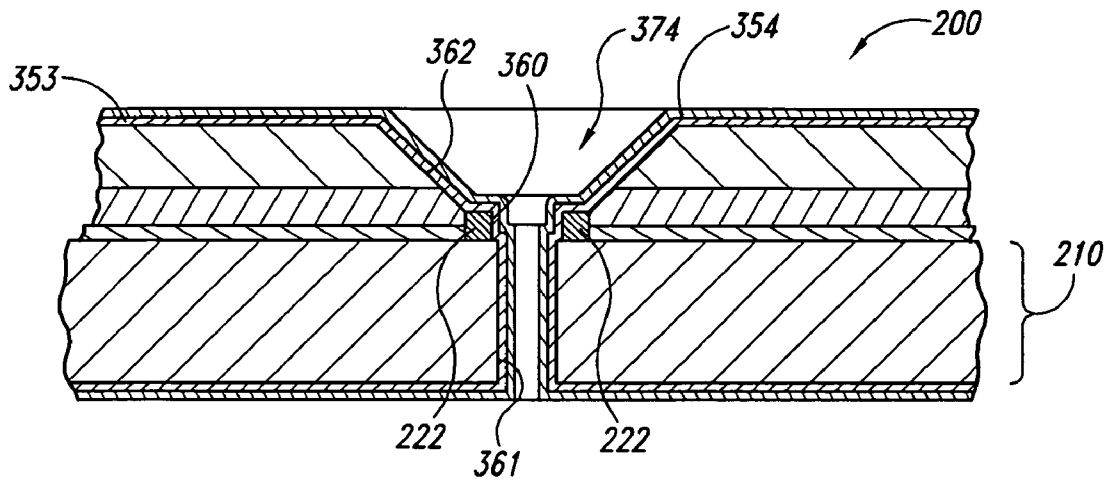

Fig. 3D

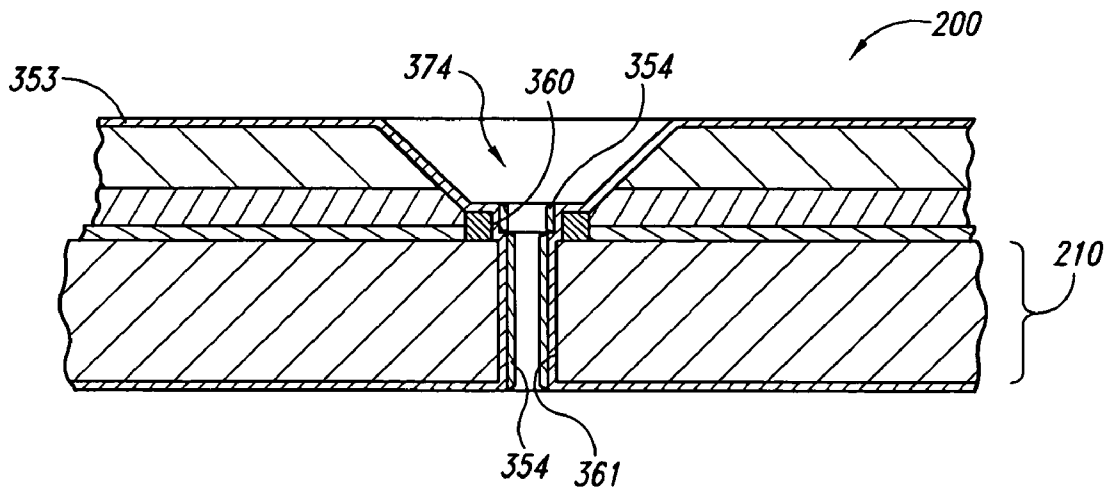

Fig. 3E

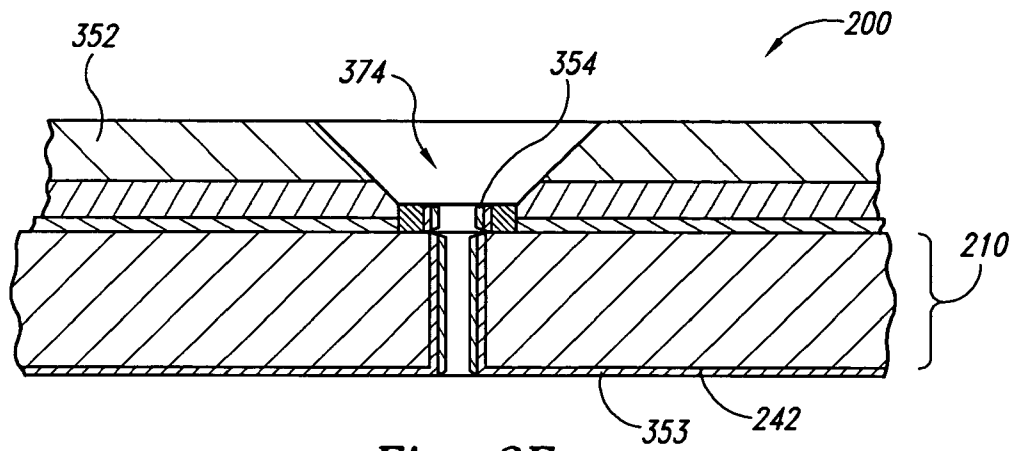

Fig. 3F

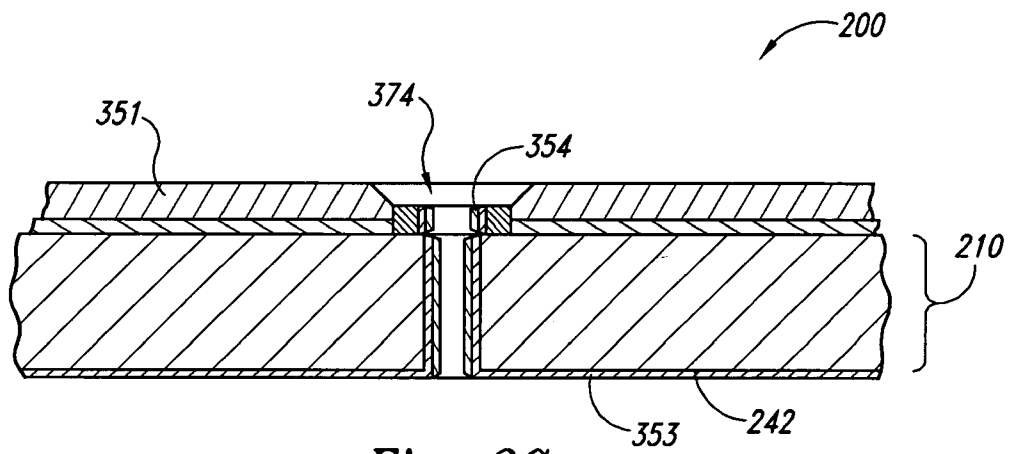

Fig. 3G

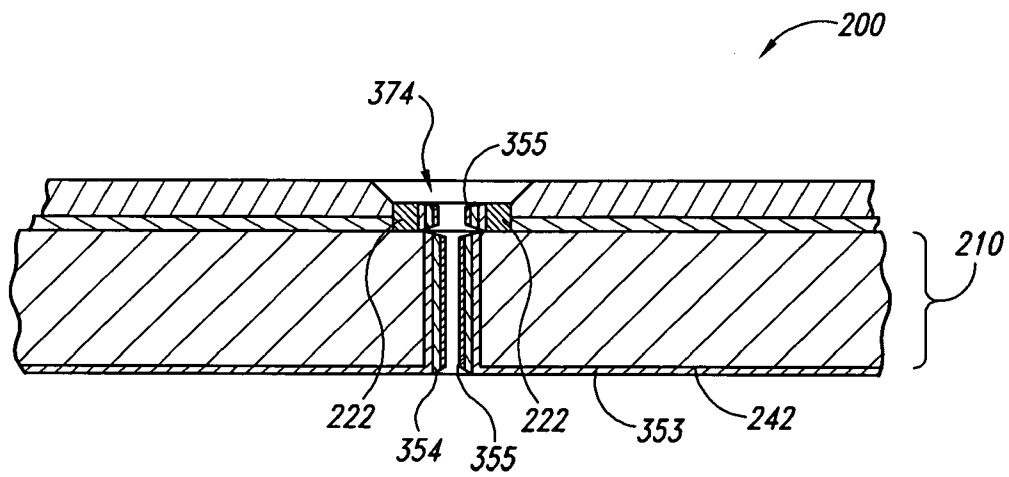

Fig. 3H

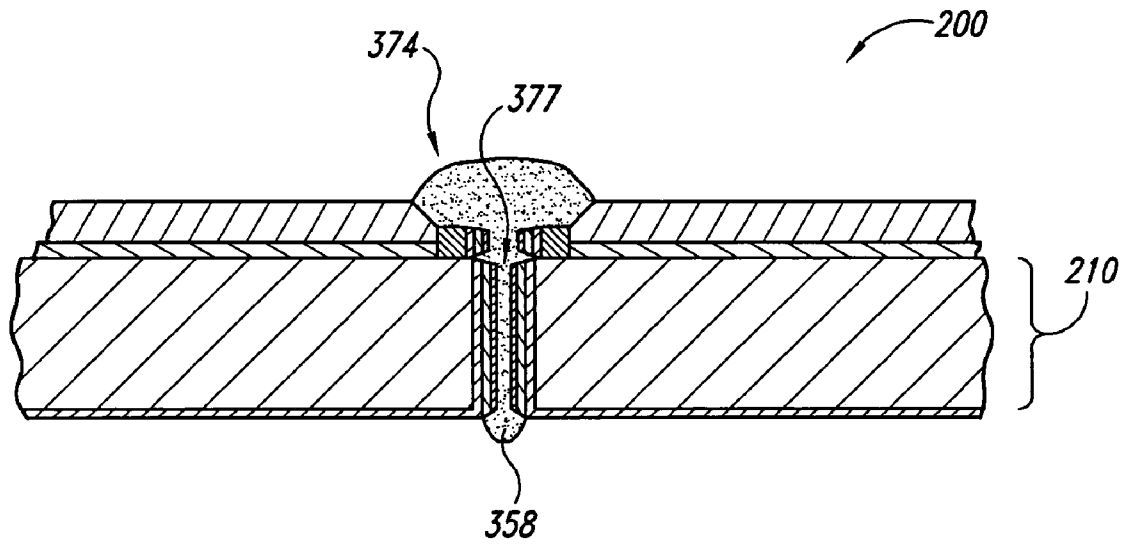

Fig. 3I

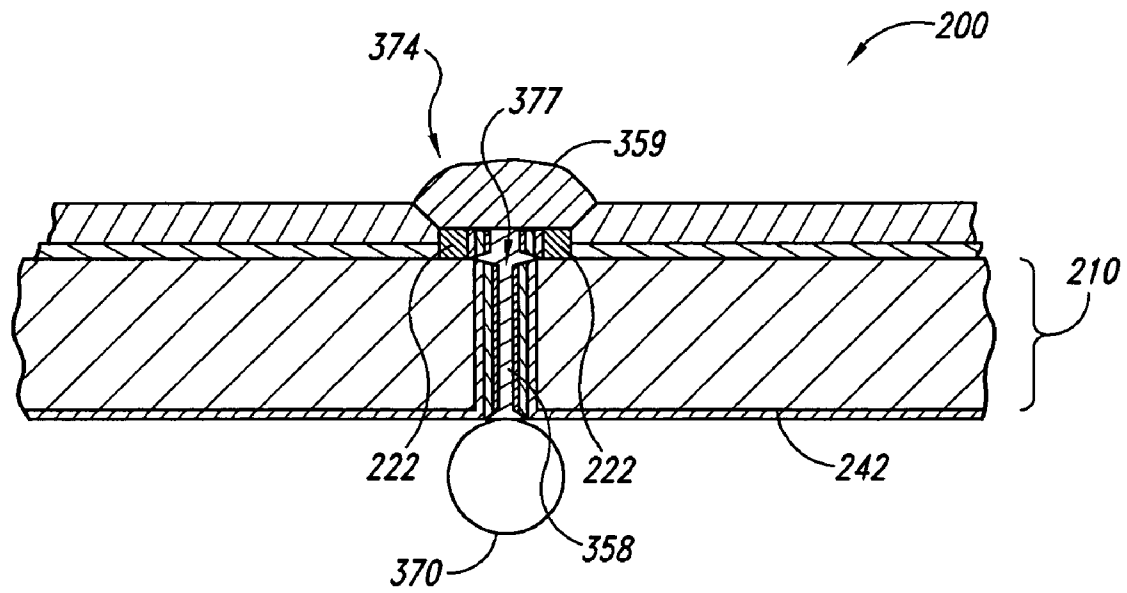

Fig. 3J

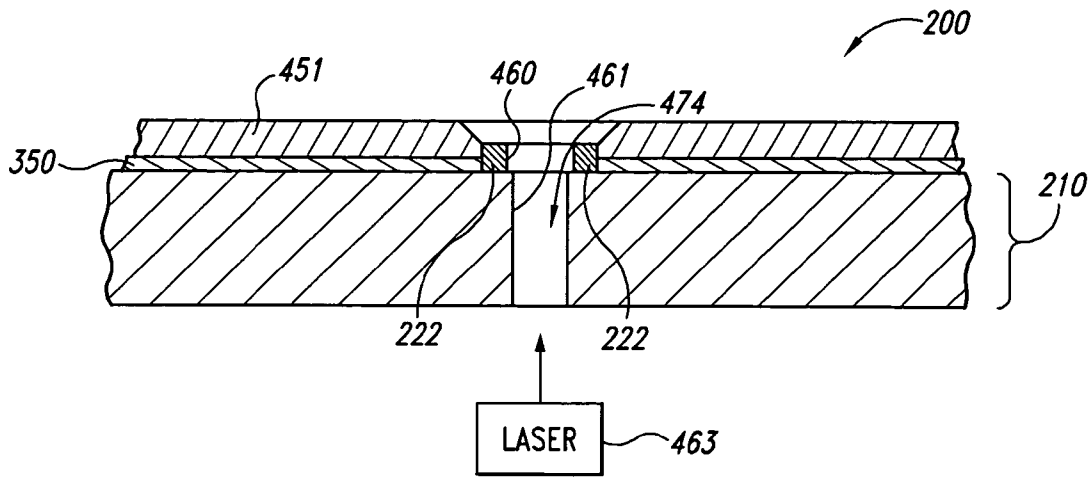

Fig. 4A

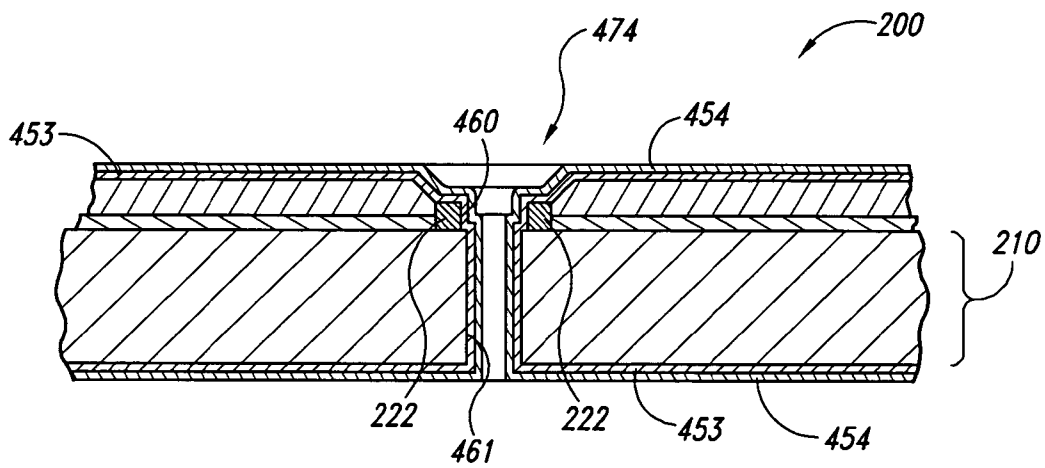

Fig. 4B

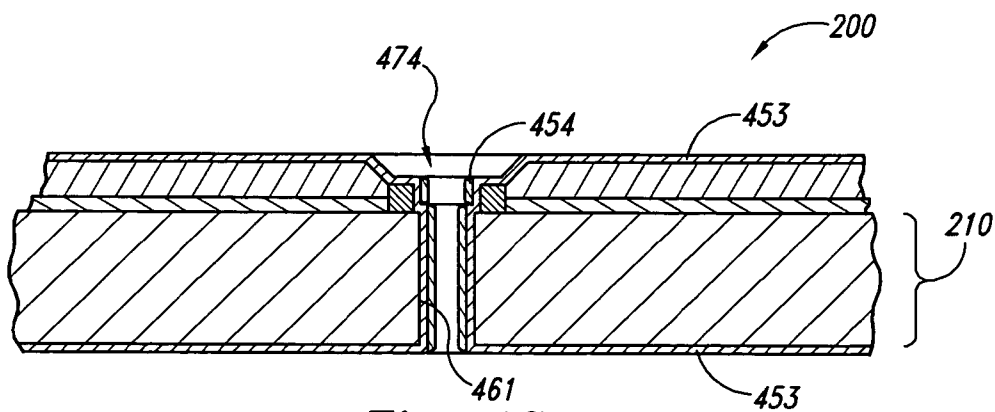

Fig. 4C

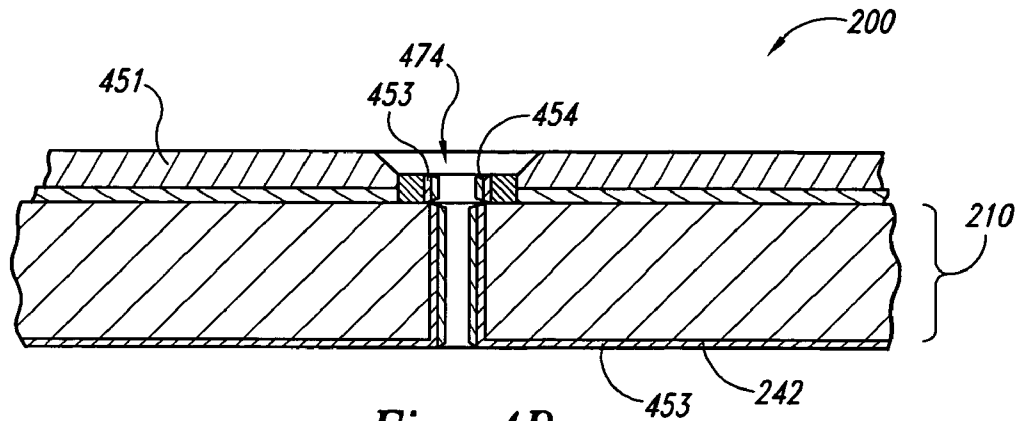

Fig. 4D

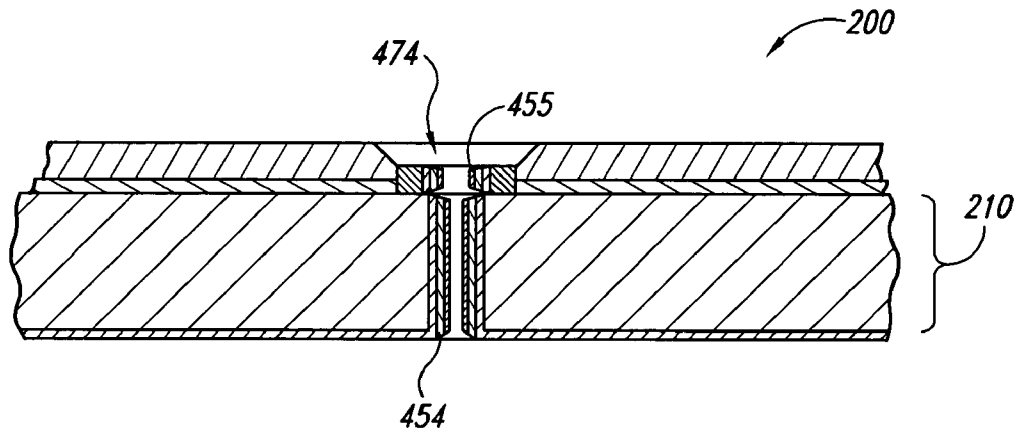

Fig. 4E

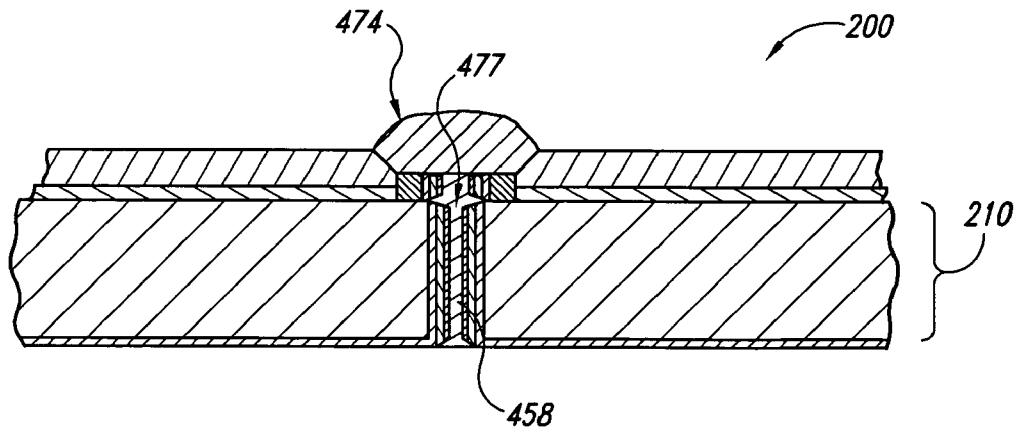

Fig. 4F

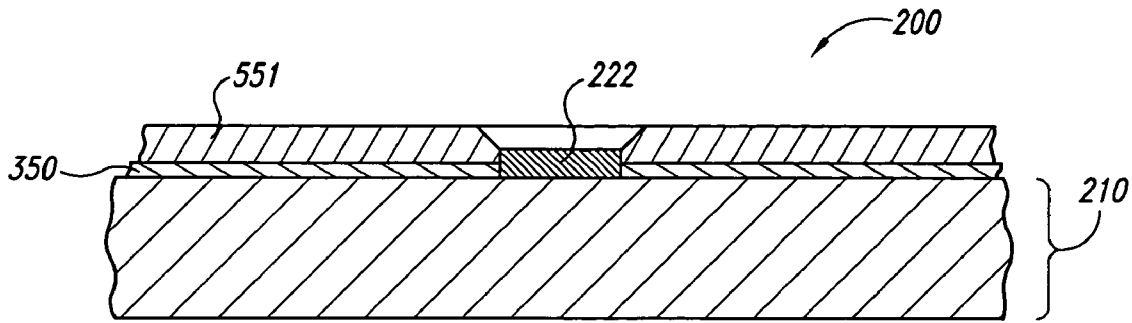

Fig. 5A

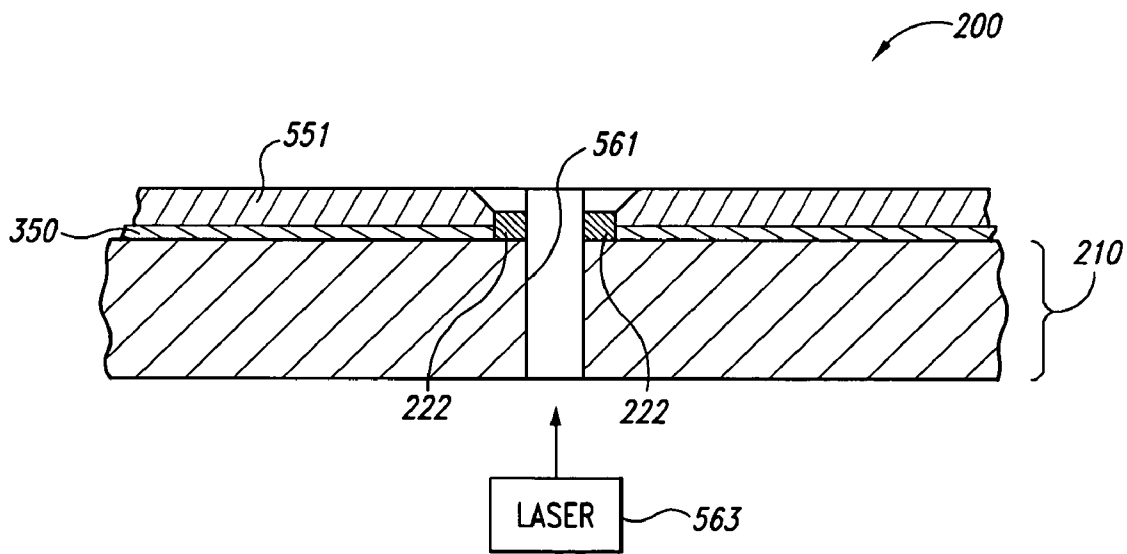

Fig. 5B

PACKAGED MICROELECTRONIC IMAGERS AND METHODS OF PACKAGING MICROELECTRONIC IMAGERS

TECHNICAL FIELD

The following disclosure relates generally to microelectronic devices and methods for packaging microelectronic devices. Several aspects of the present invention are directed toward packaging microelectronic imagers that are responsive to radiation in the visible light spectrum or radiation in other spectrums.

BACKGROUND

Microelectronic imagers are used in digital cameras, wireless devices with picture capabilities, and many other applications. Cell phones and Personal Digital Assistants (PDAs), for example, are incorporating microelectronic imagers for capturing and sending pictures. The growth rate of microelectronic imagers has been steadily increasing as they become smaller and produce better images with higher pixel counts.

Microelectronic imagers include image sensors that use Charged Coupled Device (CCD) systems, Complementary Metal-Oxide Semiconductor (CMOS) systems, or other systems. CCD image sensors have been widely used in digital cameras and other applications. CMOS image sensors are also quickly becoming very popular because they are expected to have low production costs, high yields, and small sizes. CMOS image sensors can provide these advantages because they are manufactured using technology and equipment developed for fabricating semiconductor devices. CMOS image sensors, as well as CCD image sensors, are accordingly "packaged" to protect the delicate components and to provide external electrical contacts.

FIG. 1 is a schematic view of a conventional microelectronic imager 1 with a conventional package. The imager 1 includes a die 10, an interposer substrate 20 attached to the die 10, and a housing 30 attached to the interposer substrate 20. The housing 30 surrounds the periphery of the die 10 and has an opening 32. The imager 1 also includes a transparent cover 40 over the die 10.

The die 10 includes an image sensor 12 and a plurality of bond-pads 14 electrically coupled to the image sensor 12. The interposer substrate 20 is typically a dielectric fixture having a plurality of bond-pads 22, a plurality of ball-pads 24, and traces 26 electrically coupling bond-pads 22 to corresponding ball-pads 24. The ball-pads 24 are arranged in an array for surface mounting the imager 1 to a board or module of another device. The bond-pads 14 on the die 10 are electrically coupled to the bond-pads 22 on the interposer substrate 20 by wire-bonds 28 to provide electrical pathways between the bond-pads 14 and the ball-pads 24.

The imager 1 shown in FIG. 1 also has an optics unit including a support 50 attached to the housing 30 and a barrel 60 adjustably attached to the support 50. The support 50 can include internal threads 52, and the barrel 60 can include external threads 62 engaged with the threads 52. The optics unit also includes a lens 70 carried by the barrel 60.

One problem with packaging conventional microelectronic imagers is that they have relatively large footprints and occupy a significant amount of vertical space (i.e., high profiles). The footprint of the imager in FIG. 1 is the surface area of the bottom of the interposer substrate 20. This is typically much larger than the surface area of the die 10 and can be a limiting factor in the design and marketability of

picture cell phones or PDAs because these devices are continually shrinking to be more portable. Therefore, there is a need to provide microelectronic imagers with smaller footprints and lower profiles.

Another problem with packaging conventional microelectronic imagers is the manufacturing costs for packaging the dies. Forming the wire bonds 28, for example, in the imager 1 shown in FIG. 1 can be complex and/or expensive because it requires individual wires between each set of bond-pads and ball-pads. In addition, it may not be feasible to form wire-bonds for the high-density, fine-pitch arrays of some high-performance devices. Therefore, there is a significant need to enhance the efficiency, reliability, and precision of packaging microelectronic imagers.

BRIEF DESCRIPTION OF THE DRAWINGS

FIG. 1 is a cross-sectional view of a packaged microelectronic imager in accordance with the prior art.

FIG. 2 is a side cross-sectional view schematically illustrating a microelectronic imaging die in accordance with an embodiment of the invention.

FIGS. 3A-3J are schematic side cross-sectional views illustrating various stages in a method of forming an electrically conductive interconnect through a microelectronic imaging die for providing a backside array of ball-pads in accordance with an embodiment of the invention.

FIGS. 4A-4F are schematic side cross-sectional views illustrating various stages in a method of forming an electrically conductive interconnect through a microelectronic imaging die for providing a backside array of ball-pads in accordance with another embodiment of the invention.

FIGS. 5A and 5B are schematic side cross-sectional views illustrating various stages in a method of forming an electrically conductive interconnect through a microelectronic imaging die for providing a backside array of ball-pads in accordance with another embodiment of the invention.

FIG. 6 is a schematic side cross-sectional view of an assembly including a microelectronic imager workpiece having a plurality of imaging dies and an optics workpiece having a plurality of optics units in accordance with an embodiment of the invention.

DETAILED DESCRIPTION

A. Overview

The following disclosure describes several embodiments of microelectronic imagers, methods for packaging microelectronic imagers, and methods for forming electrically conductive interconnects in microelectronic imagers. One particular embodiment of the invention is directed toward a microelectronic imaging die comprising a microelectronic substrate, an integrated circuit, and an image sensor electrically coupled to the integrated circuit. The imaging die further includes an electrical terminal (e.g., bond-pad) electrically coupled to the integrated circuit and an electrically conductive through-wafer interconnect extending through at least a portion of the substrate. One end of the interconnect contacts the bond-pad, and the other end of the interconnect can contact a ball-pad on the backside of the die.

Another particular embodiment of the invention is directed toward a method for manufacturing a microelectronic imaging die. The method can include providing a microelectronic substrate having an integrated circuit and an image sensor electrically coupled to the integrated circuit, forming a bond-pad on the substrate, and electrically cou-

pling the bond-pad to the integrated circuit. The method can further include forming a passage through the die and the bond-pad, and constructing an electrically conductive through-wafer interconnect in at least a portion of the passage so that the interconnect contacts the bond-pad. The interconnect can be constructed by depositing an electrically conductive fill material into at least a portion of the passage.

One embodiment of a method for constructing the interconnect includes cleaning the passage through the die and applying a dielectric liner to at least a portion of the passage before depositing the electrically conductive fill material into the passage. The dielectric liner electrically insulates the other components in the substrate from the electrically conductive material filling the passage. This method can further include depositing a conductive layer into at least a portion of the passage, and depositing a wetting agent over at least a portion of the conductive layer. The electrically conductive fill material can then be deposited into the passage.

Many specific details of the present invention are described below with reference to microfeature workpieces. The term "microfeature workpiece" as used throughout this disclosure includes substrates upon which and/or in which microelectronic devices, micromechanical devices, data storage elements, read/write components, and other features are fabricated. For example, such microfeature workpieces can include semiconductor wafers (e.g., silicon or gallium arsenide wafers), glass substrates, insulated substrates, and many other types of substrates. The feature sizes in microfeature workpieces can be 0.11 μm or less, but the workpieces can have larger submicron and supra-micron features.

Specific details of several embodiments of the invention are described below with reference to microelectronic imager dies and other microelectronic devices in order to provide a thorough understanding of such embodiments. Other details describing well-known structures often associated with microelectronic devices are not set forth in the following description to avoid unnecessarily obscuring the description of the various embodiments. Persons of ordinary skill in the art will understand, however, that the invention may have other embodiments with additional elements or without several of the elements shown and described below with reference to FIGS. 2-6.

In the Figures, identical reference numbers identify identical or at least generally similar elements. To facilitate the discussion of any particular element, the most significant digit or digits of any reference number refer to the Figure in which that element is first introduced. For example, element 210 is first introduced and discussed with reference to FIG. 2.

B. Microelectronic Imaging Dies with Through-Wafer Interconnects

FIG. 2 is a side cross-sectional view of a microelectronic imaging die 200 for use in a microelectronic imager in accordance with one embodiment of the invention. In this embodiment, the microelectronic imaging die 200 includes a substrate 210 having a first side 241, a second side 242 opposite the first side 241, integrated circuitry (IC) 230 within the substrate 210, and an image sensor 212 electrically coupled to the IC 230. The image sensor 212 can be a CMOS device or a CCD for capturing pictures or other images in the visible spectrum. In other embodiments, the image sensor 212 can detect radiation in other spectrums (e.g., IR or UV ranges).

The imaging die 200 further includes a plurality of external contacts 220 for carrying electrical signals. Each

external contact 220, for example, can include a bond-pad 222, a ball-pad 224, and an electrically conductive through-wafer interconnect 226 electrically coupling the bond-pad 222 to the ball-pad 224. The external contacts 220 shown in FIG. 2 accordingly provide an array of ball-pads 224 within the footprint of the imaging die 200. The ball-pads 224 can be connected to other external devices such that the imaging die 200 does not need an interposing substrate to be installed on a circuit board.

One advantage of using through-wafer interconnects 226 to electrically couple the bond-pads 222 to the ball-pads 224 is that this eliminates the need for mounting the imaging die 200 to a separate, larger interposer substrate. The imaging die 200, which has a significantly smaller footprint and profile than the interposer substrate of the conventional device shown in FIG. 1, can define the final footprint of the packaged imager. Accordingly, the imaging die 200 can be used in smaller electronic devices. Furthermore, the imaging die 200 also eliminates having to wire-bond the bond-pads to external contacts. This is useful because wire-bonds tend to break and are difficult to fabricate on high-density arrays. Accordingly, the microelectronic imaging die 200 with the through-wafer interconnects 226 is more robust than dies that require wire-bonds.

In the embodiment illustrated in FIG. 2, the processing of the imaging die 200 has been completed. As described below, FIGS. 3A-5B illustrate various embodiments of methods for forming electrically conductive through-wafer interconnects in the imaging die 200. Although the following description illustrates forming one interconnect, it will be appreciated that a plurality of interconnects are constructed simultaneously through a plurality of imaging dies on a wafer.

FIGS. 3A-3J schematically illustrate various stages in a method of forming the through-wafer interconnect 226 in the imaging die 200 in accordance with an embodiment of the invention. FIG. 3A, more specifically, is a schematic side cross-sectional view of the area 3A shown on FIG. 2. In this embodiment, a first dielectric layer 350 is applied to the first side 241 of the substrate 210, and a second dielectric layer 351 is applied over the first dielectric layer 350. A portion of the second dielectric layer 351 over the bond-pad 222 is removed by etching or another known process to expose the bond-pad 222. After exposing the bond-pad 222, a first hole 360 is formed through the bond-pad 222. The first hole 360 can be formed by etching the center of the bond-pad 222, but in other embodiments the first hole 360 can be formed using other suitable methods (e.g., laser).

Referring now to FIG. 3B, a third dielectric layer 352 is applied over the imaging die 200 to cover the bond-pad 222 and fill the first hole 360. In one embodiment the first, second, and third dielectric layers 350, 351, 352 are a polyimide material, but these dielectric layers can be other nonconductive materials in other embodiments. For example, the first dielectric layer 350 and/or one or more subsequent dielectric layers can be a low temperature chemical vapor deposition (low temperature CVD) material, such as tetraethylorthosilicate (TEOS), parylene, silicon nitride (Si_3N_4), silicon oxide (SiO_2), and/or other suitable materials. The foregoing list of dielectric materials is not exhaustive. The dielectric layers 350, 351, 352 are not generally composed of the same materials as each other, but it is possible that two or more of these layers are composed of the same material. In addition, one or more of the layers described above with reference to FIGS. 3A and 3B, or described below with reference to subsequent figures, may be omitted.

FIGS. 3C-3J are schematic side cross-sectional views similar to FIGS. 3A and 3B showing the imaging die 200 in subsequent stages of forming the through-wafer interconnect. FIG. 3C, for example, is a schematic side cross-sectional view of the imaging die 200 after a second hole 362 has been formed through the third dielectric layer 352. The second hole 362 is formed by removing a portion of the third dielectric layer 352 to open the first hole 360 and expose the bond-pad 222. The second hole 362 can be formed by etching or by other suitable methods known to those of skill in the semiconductor processing art.

FIG. 3C further illustrates cutting a passage or through-hole 361 through the substrate 210. The through-hole 361 extends through the substrate 210 to the first hole 360 in the bond-pad 222. For ease of reference, the through-hole 361 and the first hole 360 together form passage 374 extending through the imaging die 200 in the embodiment shown in FIG. 2. The through-hole 361 can be formed using a laser 363 (shown schematically) to cut through the die 200 from the second side 242 toward the first side 241. In a different embodiment, the laser 363 can conceivably cut from the first side 241 toward the second side 242. The laser 363 can be aligned with respect to the bond-pad 222 using scanning/alignment systems known in the art. In other embodiments, the through-hole 361 can be formed by suitable etching processes if the wafer is not too thick.

After forming the through-hole 361, it is cleaned to remove ablated byproducts (i.e., slag) and/or other undesirable byproducts resulting from the laser cut. The through-hole 361 can be cleaned using a wet-etch process. In the embodiment shown in FIG. 3C, the cross-sectional dimension of the through-hole 361 is less than the cross-sectional dimension of the first hole 360 in the bond-pad 222 so that the laser 363 does not impinge against the bond-pad 222. This avoids producing slag of one material in the first hole 360 through the bond-pad 222 and slag of a different material in the through-hole 361 through the substrate 210. This feature allows a single cleaning process/chemistry to clean the slag from the through-hole 361 without having to use a second cleaning process to clean residue from the first hole 360. For example, cleaning agents that do not attack the metal of the bond-pad 222 can be used to clean slag from the through-hole 361. One such cleaning agent may include 6% tetramethylammonium hydroxide (TMAH); propylene glycol for removing laser ablated byproducts. Alternatively, in certain other embodiments the through-hole 361 is not cleaned after formation.

Referring to FIG. 3D, a fourth dielectric layer 353 is applied to the imaging die 200 to at least cover the sidewall of the through-hole 361 in the substrate 210. The fourth dielectric layer 353 can be applied using CVD, PVD, ALD or other deposition processes. In the illustrated embodiment the fourth dielectric layer 353 is applied to the entire imaging die 200 so that it covers the exposed portions of the substrate 210, the bond-pad 222, and the third dielectric layer 352. The fourth dielectric layer 353 can be a low temperature CVD oxide, but in other embodiments the fourth dielectric layer 353 can be other suitable dielectric materials. The fourth dielectric layer 353 electrically insulates the components of the substrate 210 from an interconnect that is subsequently formed in the passage 374 as described in greater detail below.

After applying the fourth dielectric layer 353, a first conductive layer 354 is deposited onto the imaging die 200. In the illustrated embodiment, the first conductive layer 354 covers the fourth dielectric layer 353. The first conductive layer 354 is generally a metal layer, such as a TiN layer, but

in other embodiments the first conductive layer 354 can be composed of TaN, W, WN, Ta, Ti, Al, Cu, Ag, Au, Ni, Co and/or other suitable materials known to those of skill in the art. When the first conductive layer 354 is composed of TiN, it can be formed using TiCl_4/TiN and an atomic layer deposition (ALD) or chemical vapor deposition (CVD) process. As explained below, the first conductive layer 354 provides a material for plating another layer of metal onto only selected areas of the wafer (e.g., in the through-hole 361).

Referring next to FIG. 3E, portions of the first conductive layer 354 are removed from the horizontal and diagonal surfaces of the imaging die 200. In one embodiment, such portions of the first conductive layer 354 are removed from these surfaces by a suitable etching process, such as a "dry etch" or "spacer etch" that preferentially removes material at a higher etch rate from horizontal surfaces and surfaces having horizontal components relative to the direction of the etchant. In other embodiments, different processes can be used to selectively remove non-vertical portions of the first conductive layer 354 so that the vertical portions of the first conductive layer 354 on the sidewalls in the holes 360 and 361 remain on the workpiece.

Referring next to FIGS. 3F and 3G, portions of the third dielectric layer 352 and fourth dielectric layer 353 on horizontal and diagonal surfaces of the first side 241 of the imaging die 200 are removed. The portion of the fourth dielectric layer 353 on the second side 242 of the substrate 210 remains on the imaging die 200 in this embodiment. In one embodiment, the third dielectric layer 352 and fourth dielectric layer 353 can be removed from the horizontal and diagonal surfaces of the imaging die 200 by a suitable etching process, such as a dry etch or spacer etch as described above.

Referring to FIG. 3H, a second conductive layer 355 is applied to the remaining portions of the first conductive layer 354 in the holes 360 and 361. The second conductive layer 355 can act as a wetting agent to facilitate depositing metals into the passage 374. The second conductive layer 355 can be Ni that is deposited onto a first conductive layer 354 composed of TiN in an electroless plating operation. When the TiN is activated by an $\text{HF}:\text{Pd}$ wet dip, it provides nucleation for the Ni during the plating process. The plating process may also be performed using an activationless Ni chemistry with reduced stabilizer content. The TiN can enhance the adhesion and electrical properties to induce nucleation. In other embodiments, the passage 374 can be coated with Cu, Au, or other suitable materials using other methods, or one or more of the first and second conductive layers 354, 355 may be omitted.

Referring next to FIG. 3I, a conductive fill material 358 is deposited into the passage 374 to form an interconnect 377 extending through the imaging die 200. In one aspect of this embodiment, the fill material 358 can be solder, copper, or other electrically conductive materials. Various processes can be used to deposit the fill material 358 into the passage 374. In one embodiment, the fill material 358 can be deposited into the passage 374 using a solder wave process. In other embodiments, the fill material 358 can be deposited by electroplating, stenciling, placing a pre-formed sphere of metal fill in the passage 374 and melting the sphere, or injecting a flowable material into the passage 374. Alternatively, in still further embodiments, the fill material 358 can be deposited into the passage 374 using other methods known to those of skill in the art.

Referring next to FIG. 3J, a cap 359 can be formed at one end of the interconnect 377 after depositing the fill material

358 into the passage **374**. The cap **359** electrically couples the interconnect **377** with the bond-pad **222**. In one embodiment, the cap **359** can be Ni electroplated onto the interconnect **377**. In other embodiments, the cap **359** can be a wetting agent and/or other material. Alternatively, the cap **359** can be a portion of the fill material itself, or the cap **359** can be omitted. In another aspect of this embodiment, a solder ball **370** is attached to the interconnect **377** at the second side **242** of the substrate **210** to provide an external connection to other electronic devices on the backside of the imaging die **200**.

In addition to requiring only a single cleaning process for the through-hole **361**, another feature of the embodiments described above with reference to FIGS. **3A-3J** is that the passage **374** extends through the entire imaging die **200**. One advantage of this feature is that it makes the passage **374** easier to clean and fill than would otherwise be the case if the passage were "blind" (i.e., a passage that extends only partially through the workpiece). For example, in certain applications where the passage **374** has an aspect ratio of 25-30:1 or greater, a blind passage is difficult to fill with metallic materials using known physical vapor deposition (PVD), ALD, or plating processes. The passage **374** mitigates this problem because the open through-hole is not subject to "pinch-off," voids or other phenomena of filling blind holes.

FIGS. **4A-4F** illustrate stages in a method of forming a through-wafer interconnect in an imaging die **200** in accordance with another embodiment of the invention. The initial stage of this method is at least generally similar to the steps described above with reference to FIG. **3A**, and thus FIG. **4A** shows the workpiece configuration illustrated in FIG. **3A**. The subsequent stages of this method, however, differ from those described above with reference to FIGS. **3B-3F** in that a third dielectric layer is not applied over the second dielectric layer **451** before cutting a through-hole **461** through the substrate **210**. Therefore, referring first to FIG. **4A**, the through-hole **461** is formed through the substrate **210** without having a third dielectric layer over the second dielectric layer **451**. For ease of reference, the passage formed by the through-hole **461** and a first hole **460** through the bond-pad **222** is referred to as a via or passage **474** extending through the imaging die **200**. The through-hole **461** can be formed using a laser **463** (shown schematically), etching, or other suitable processes as described above.

FIG. **4B** illustrates additional stages of this method that are generally similar to the steps described above with reference to FIG. **3D**. In a further aspect of this embodiment, however, after cleaning the through-hole **461**, a third dielectric layer **453** is deposited onto the imaging die **200** to cover the sidewall of the through-hole **461** within the substrate **210**. In, practice, the third dielectric layer **453** generally covers the bond-pad **222** and the second dielectric layer **451** in addition to the exposed portion of the substrate **210** in the through-hole **461**.

After forming the third dielectric layer **453**, a first conductive layer **454** is deposited onto the imaging die **200**. In the illustrated embodiment, the first conductive layer **454** covers the entire third dielectric layer **453**. As explained above, the first conductive layer **454** can be a TiN layer, but the first conductive layer **454** can be a different material.

Referring next to FIG. **4C**, a portion of the first conductive layer **454** is removed from the horizontal and diagonal surfaces of the imaging die **200**. The first conductive layer **454** can be removed from these surfaces by a spacer etch or other process described above with respect to FIG. **3E**.

Referring to FIG. **4D**, the portions of the third dielectric layer **453** on the upper horizontal and diagonal surfaces of the imaging die **200** are then removed to leave portions of the third dielectric layer **453** in the passageway **474** and on the second side **242** of the substrate **210**. The portions of the third dielectric layer **453** on the upper horizontal and diagonal surfaces of the imaging die **200** can be removed by another spacer etch. The spacer etch of the third dielectric layer **453** should be terminated before etching through the second dielectric layer **451**.

Referring to FIG. **4E**, a second conductive layer **455** is then deposited onto the first conductive layer **454**. The second conductive layer **455** can be a wetting agent to facilitate filling the passage **474** with a conductive material. The second conductive layer **455** can be generally similar to the second conductive layer **355** described above with respect to FIG. **3H**. Referring next to FIG. **4F**, a fill material **458** is deposited into the passageway **474** to construct a through-wafer interconnect **477** in a procedure generally similar to that described above with reference to FIGS. **31-3J**.

FIGS. **5A** and **5B** illustrate stages in a method of forming an interconnect in an imaging die **200** in accordance with another embodiment of the invention. Referring first to FIG. **5A**, the first part of this method can be at least generally similar to the steps described above with reference to FIG. **3A**. However, after a second dielectric layer **551** is etched to expose the bond-pad **222**, a hole is not etched in the bond-pad **222**.

Referring next to FIG. **5B**, a through-hole **561** can be formed through the substrate **210** and the bond-pad **222**. The through-hole **561** can be formed using a laser **563** (shown schematically), etching, or other suitable processes. When the laser **563** is used to form the through-hole **561**, a first type of slag can coat the portion of the sidewall in the substrate **210** and a second type of slag can coat the portion of the sidewall in the bond-pad **222**. As such, it may take two separate cleaning steps to clean the through-hole **561**. In general, the cleaning agents used to clean the through-hole **561** may be limited to those chemistries that do not attack or otherwise degrade the metal of the bond-pad **222** or the material of the substrate **210**. After the through-hole **561** has been suitably cleaned, the imaging die **200** can undergo additional packaging steps that are at least generally similar to those described above with reference to FIGS. **3C-3J** to construct a through-wafer interconnect as illustrated in FIG. **3J**.

The embodiments described above with reference to FIGS. **3A-5B** include three methods for forming and/or filling through-holes in microfeature workpieces that extend through bond-pads and/or associated substrates. In other embodiments, other methods can be used to form and/or fill such through-holes. Accordingly, the present invention is not limited to the particular methods for forming and/or filling the through-holes described above, but it also includes alternative methods for providing an electrically conductive material in a through-hole to form an array of ball-pads on the backside of the imager die.

C. Microelectronic Imagers with Through-Wafer Interconnects

FIG. **6** is a schematic cross-sectional view of an assembly **600** including a plurality of microelectronic imagers **690** that each include an imaging die **200** and an optics unit **640**. The assembly **600** includes a microelectronic imager workpiece **602** having a first substrate **604** and a plurality of imaging dies **200** formed on the first substrate **604**. The individual

imaging dies **200** can be generally similar to the imaging die **200** described above with respect to FIG. 2; like reference numbers accordingly refer to like components in FIGS. 2 and 6. The assembly **600** also includes an optics workpiece **630** that includes a second substrate **634** and a plurality of optics units **640** on the second substrate **634**. Individual optic units **640** can include an optic member **650** on the second substrate **634**. The optic member **650** can include lenses and/or filters for focusing and filtering the radiation passing through the optics unit **640**.

The assembly **600** further includes a plurality of stand-offs **660** configured to position individual optic units **640** with respect to individual image sensors **212**. Suitable stand-offs are disclosed in U.S. patent application Ser. No. 10/723,363, filed on Nov. 26, 2003, which is incorporated by reference herein. The microelectronic imagers **690** can be assembled by seating the stand-offs **660** so that the optics units **640** are accurately aligned with the image sensors **212**. In one embodiment, the stand-offs **660** are seated before singulating the individual imagers **690** such that all of the microelectronic imagers are assembled at the wafer level. Both of the first and second substrates **604** and **634** can then be cut along lines A-A to separate individual imagers **690** from each other.

One advantage of the assembly **600** of microelectronic imagers **690** illustrated in FIG. 6 is that the through-wafer interconnects **226** enable a plurality of microelectronic imagers to be fabricated at the wafer level using semiconductor fabrication techniques. Because the through-wafer interconnects **226** provide an array of ball-pads **224** on the backside of the imaging dies **200**, it is not necessary to wire-bond the bond-pads **222** on the front side of the wafer to external devices. The bond-pads **222** can accordingly be covered at the wafer level. This enables the process of (a) fabricating a plurality of imaging dies **200** at the wafer level on one substrate, (b) fabricating a plurality of optics units **640** at the wafer level on another substrate, and (c) assembling a plurality of optic units **640** with a corresponding plurality of imaging dies **200** at the wafer level using automated equipment. Therefore, the microelectronic imagers **690** with through-wafer interconnects **226** enable processes that significantly enhance the throughput and accuracy of packaging microelectronic imagers.

Another advantage of the assembly **600** of microelectronic imagers **690** is the ability to decrease the real estate that the imagers **690** occupy in a cell phone, PDA, or other type of device. Because the imagers **690** do not require an interposer substrate to provide external electrical contacts in light of the through-wafer interconnects **226**, the footprint of the imagers **690** can be the same as that of the die **200** instead of the interposer substrate. The area occupied by the imagers **690** is accordingly less than conventional imagers because the footprint of the individual imaging dies **200** is significantly smaller than that of the interposer substrate. Furthermore, because the dies **200** provide a backside array of ball-pads **224** that can be coupled directly to a module without an interposer substrate, the profile is lower and the time and costs associated with mounting the die to the interposer substrate are eliminated. This results in greater throughput, lower packaging costs, and smaller imagers.

A further advantage of wafer-level imager packaging is that the microelectronic imagers **690** can be tested from the backside of the dies **200** at the wafer level before the individual imagers **690** are singulated. A test probe can contact the backside of the dies **200** to test the individual microelectronic imagers **690** because the through-wafer interconnects **226** provide backside electrical contacts.

Accordingly, because the test probe engages contacts on the backside of the imager workpiece **602**, it will not damage the image sensors **212**, the optics units **640**, or associated circuitry on the front of the microelectronic imagers **690**. Moreover, the test probe does not obstruct the image sensors **212** during a backside test, which allows the test probe to test a larger number of dies at one time compared to processes that test imaging dies from the front side. As such, it is more efficient in terms of cost and time to test the microelectronic imagers **690** at the wafer level (i.e., before singulation) than to test each imager **690** from the front side of the dies **200**. Furthermore, it is advantageous to test the microelectronic imagers **690** in an environment where the individual image sensors **212** and/or optics units **640** will not be damaged during testing.

Yet another advantage of wafer-level processing is that the microelectronic imagers **690** can be singulated after assembling the optics units **640** to the dies **200**. The attached optics units **640** protect the imager sensors **212** on the front side of the dies **200** from particles generated during the singulation process. Thus, the likelihood that the image sensors **212** or associated circuitry on the front side of the dies **200** will be damaged during singulation and subsequent handling is significantly reduced.

From the foregoing, it will be appreciated that specific embodiments of the invention have been described herein for purposes of illustration, but that various modifications may be made without deviating from the spirit and scope of the invention. For example, various aspects of any of the foregoing embodiments can be combined in different combinations. Accordingly, the invention is not limited except as by the appended claims.

We claim:

1. A microelectronic imaging die, comprising:
 - a microelectronic substrate having a first side and a second side opposite the first side, an image sensor, and an integrated circuit in the substrate electrically coupled to the image sensor;
 - a terminal carried by the substrate and electrically coupled directly to the integrated circuit;
 - an electrically conductive interconnect extending from the first side to the second side of the substrate and contacting the terminal;
 - a first through-hole in the terminal, the first through-hole having a first cross-sectional dimension; and
 - a second through-hole in the substrate, the second through-hole having a second cross-sectional dimension, wherein the second cross-sectional dimension is less than the first cross-sectional dimension, and wherein the interconnect is disposed in both the first and second through-holes.
2. The microelectronic imaging die of claim 1 wherein: the interconnect comprises a dielectric liner in contact with the substrate, a first conductive layer disposed over at least a portion of the dielectric liner, a second conductive layer disposed over at least a portion of the first conductive layer and the terminal, and an electrically conductive fill material over at least a portion of the second conductive layer and electrically coupled to the terminal.
3. The microelectronic imaging die of claim 1 wherein: the interconnect comprises a dielectric liner in contact with the substrate, a conductive layer over at least a portion of the dielectric liner, wherein the conductive layer includes TiN, TaN, W, WN, Ta, Ti, Al, Cu, Ag, Ni, Cu, Co and/or Au, a wetting agent over at least a portion of the conductive layer and the terminal,

11

wherein the wetting agent includes Ni, Cu, and/or Au, and a metal fill at least partially over at least a portion of the wetting agent and electrically coupled to the terminal.

4. The microelectronic imaging die of claim 1 wherein the image sensor and terminal are on the first side of the substrate.

5. The microelectronic imaging die of claim 1 wherein: the terminal is on the first side of the substrate; and the imaging die further comprises a dielectric layer disposed on the first side of the substrate, wherein the dielectric layer covers at least a portion of the terminal.

6. The microelectronic imaging die of claim 5 wherein the dielectric layer includes Si_3N_4 and/or SiO_2 .

7. The microelectronic imaging die of claim 1 wherein: the image sensor and the terminal are on the first side of the substrate; the imaging die further comprises a ball-pad on the second side of the substrate; and the interconnect extends through the substrate electrically coupling the terminal and the ball-pad.

8. The microelectronic imaging die of claim 1 wherein: the interconnect has a first end portion coupled to the terminal and a second end portion spaced apart from the first end portion; and the imaging die further comprises a ball-pad coupled to the second end portion of the interconnect.

9. The microelectronic imaging die of claim 1 wherein: the interconnect has a first end portion coupled to the terminal and a second end portion spaced apart from the first end portion; and the imaging die further comprises a solder ball electrically coupled to the second end portion of the interconnect.

10. A microelectronic imaging die, comprising: a microelectronic substrate having a first side and a second side opposite the first side, an integrated circuit at least partially between the first and second sides, and an image sensor on the first side electrically coupled to the integrated circuit;

a bond-pad at least proximate to the first side of the substrate and electrically coupled directly to the integrated circuit having a through-hole, the through-hole having a first cross-sectional dimension; and

an electrically conductive interconnect extending through a through-hole in the substrate having a second cross-sectional dimension from the first side of the substrate to the second side of the substrate and through the through-hole in the bond-pad,

wherein the second cross-sectional dimension is less than the first cross-sectional dimension.

11. The microelectronic imaging die of claim 10 wherein: the interconnect comprises a dielectric liner in contact with the substrate, a first conductive layer disposed over at least a portion of the dielectric liner, a second conductive layer disposed over at least a portion of the first conductive layer and the bond-pad, and an electrically conductive fill over at least a portion of the second conductive layer and electrically coupled to the bond-pad.

12. The microelectronic imaging die of claim 10 wherein: the interconnect comprises a dielectric liner in contact with the substrate, a conductive layer over at least a portion of the dielectric liner, wherein the conductive layer includes TiN, TaN, W, WN, Ta, Ti, Al, Cu, Ag, Ni, Cu, Co and/or Au, a wetting agent over at least a portion of the conductive layer and the bond-pad, wherein the wetting agent includes Ni, Cu, and/or Au,

12

and a metal fill over at least a portion of the wetting agent and electrically coupled to the bond-pad.

13. The microelectronic imaging die of claim 10, further comprising a dielectric layer disposed on the first side of the substrate, wherein the dielectric layer covers at least a portion of the bond-pad.

14. The microelectronic imaging die of claim 13 wherein the dielectric layer includes Si_3N_4 and/or SiO_2 .

15. The microelectronic imaging die of claim 10 wherein: the imaging die further comprises a ball-pad on the second side of the substrate; and the interconnect extends through the substrate electrically coupling the bond-pad and the ball-pad.

16. The microelectronic imaging die of claim 10 wherein: the interconnect has a first end portion coupled to the bond-pad and a second end portion spaced apart from the first end portion; and the imaging die further comprises a ball-pad on the second side of the substrate coupled to the second end portion of the interconnect.

17. The microelectronic imaging die of claim 10 wherein: the interconnect has a first end portion coupled to the bond-pad and a second end portion spaced apart from the first end portion; and

the imaging die further comprises a solder ball electrically coupled to the second end portion of the interconnect.

18. A microelectronic imaging die, comprising:

a microelectronic substrate having a first side and a second side opposite the first side, an integrated circuit at least partially between the first and second sides, and an image sensor on the first side electrically coupled to the integrated circuit;

a bond-pad at least proximate to the first side of the substrate and electrically coupled to the integrated circuit;

an electrically conductive interconnect extending through the substrate from the first side of the substrate to the second side of the substrate and through the bond-pad; a first through-hole in the bond-pad, the first through-hole having a first cross-sectional dimension; and

a second through-hole in the substrate, the second through-hole having a second cross-sectional dimension; wherein the second cross-sectional dimension is less than the first cross-sectional dimension, and wherein the interconnect is disposed in both the first and second through-holes.

19. A microelectronic imaging die, comprising:

a microelectronic substrate having a first side and a second side opposite the first side;

an image sensor on the first side of the substrate;

an integrated circuit in the substrate and electrically coupled to the image sensor;

a bond-pad array having a plurality of bond-pads on the first side of the substrate, each bond-pad being electrically coupled directly to the integrated circuit and at least one bond-pad having a through-hole with a first cross-sectional dimension;

a ball-pad array having a plurality of ball-pads on the second side of the substrate; and

a plurality of electrically conductive interconnects extending through through-holes in the substrate from the first side to the second side of the substrate and between the integrated circuit and corresponding ball-pads, wherein the interconnects are configured to electrically couple the integrated circuit to the ball-pads within the footprint of the substrate and wherein at least

13

one through-hole in the substrate has a second cross-sectional dimension less than the first cross-sectional dimension.

20. The microelectronic imaging die of claim 19, wherein the interconnects are electrically coupled to corresponding bond-pads.

21. The microelectronic imaging die of claim 19 wherein: the individual interconnects have a first end portion and a second end portion spaced apart from the first end portion; corresponding ball-pads are coupled to the second end portions of each interconnect; and corresponding bond-pads are coupled to the first end portions of each interconnect.

22. A microelectronic imaging die, comprising: a microelectronic substrate having a first side and a second side opposite to the first surface; an image sensor on the first side of the substrate; an integrated circuit in the substrate and electrically coupled to the image sensor; a bond-pad array on the first side of the substrate and electrically coupled directly to the integrated circuit, at least one bond-pad having a through-hole with a first cross-sectional dimension; a ball-pad array on the second side of the substrate; and means extending through through-holes in the substrate from the first side to the second side of the substrate for electrically coupling the integrated circuit to the ball-pad array, wherein at least one through-hole in the substrate has a second cross-sectional dimension less than the first cross-sectional dimension.

23. A microfeature workpiece having a front side and a back side opposite the front side, the microfeature workpiece comprising:

a plurality of microelectronic dies, wherein individual dies include an integrated circuit, an image sensor, an array of bond-pads electrically coupled directly to the integrated circuit, at least one bond-pad having a through-hole with a first cross-sectional dimension, and a plurality of interconnects extending through through-holes in the microfeature workpiece, wherein individual interconnects are electrically coupled to corresponding bond-pads; and

a plurality of scribe lanes spacing apart the individual dies, wherein at least one through-hole in the microfeature workpiece has a second cross-sectional dimension less than the first cross-sectional dimension.

14

24. The microfeature workpiece of claim 23, further comprising a plurality of optics units having optic members, the individual optics units being attached to corresponding dies with individual optic members at a desired location relative to corresponding image sensors on individual dies.

25. A microelectronic device set, comprising: a first microelectronic die, comprising:

a first substrate with a first integrated circuit, a first bond-pad directly electrically coupled to the first integrated circuit and having a through-hole with a first cross-sectional dimension, and an image sensor electrically coupled to the integrated circuit; and

a first electrically conductive interconnect extending through a through-hole in the first substrate from a second side of the first substrate to a first side of the first substrate opposite the second side of the first substrate and in contact with the first bond-pad on the first side of the first substrate, the through-hole in the first substrate having a cross-sectional dimension less than the first cross-sectional dimension, and

at least a second microelectronic die having a second substrate with a second integrated circuit, a second bond-pad electrically coupled to the second integrated circuit, and a second electrically conductive interconnect extending through the second substrate in contact with the second bond-pad; wherein the second microelectronic die is in contact with the first microelectronic die.

26. A microelectronic imaging die, comprising: a microelectronic substrate having a first side and a second side opposite the first side, an image sensor, and an integrated circuit in the substrate electrically coupled to the image sensor;

a terminal carried by the substrate and electrically coupled to the integrated circuit;

an electrically conductive interconnect extending through the substrate and contacting the terminal;

a first through-hole in the terminal, the first through-hole having a first cross-sectional dimension; and

a second through-hole in the substrate, the second through-hole having a second cross-sectional dimension,

wherein the second cross-sectional dimension is less than the first cross-sectional dimension, and wherein the interconnect is disposed in both the first and second through-holes.

* * * * *