

(No Model.)

A. J. BEATON.  
PIPE HANGER.

No. 546,462.

Patented Sept. 17, 1895.

Fig. 1.

Fig. 2.

Fig. 3.

Fig. 4.

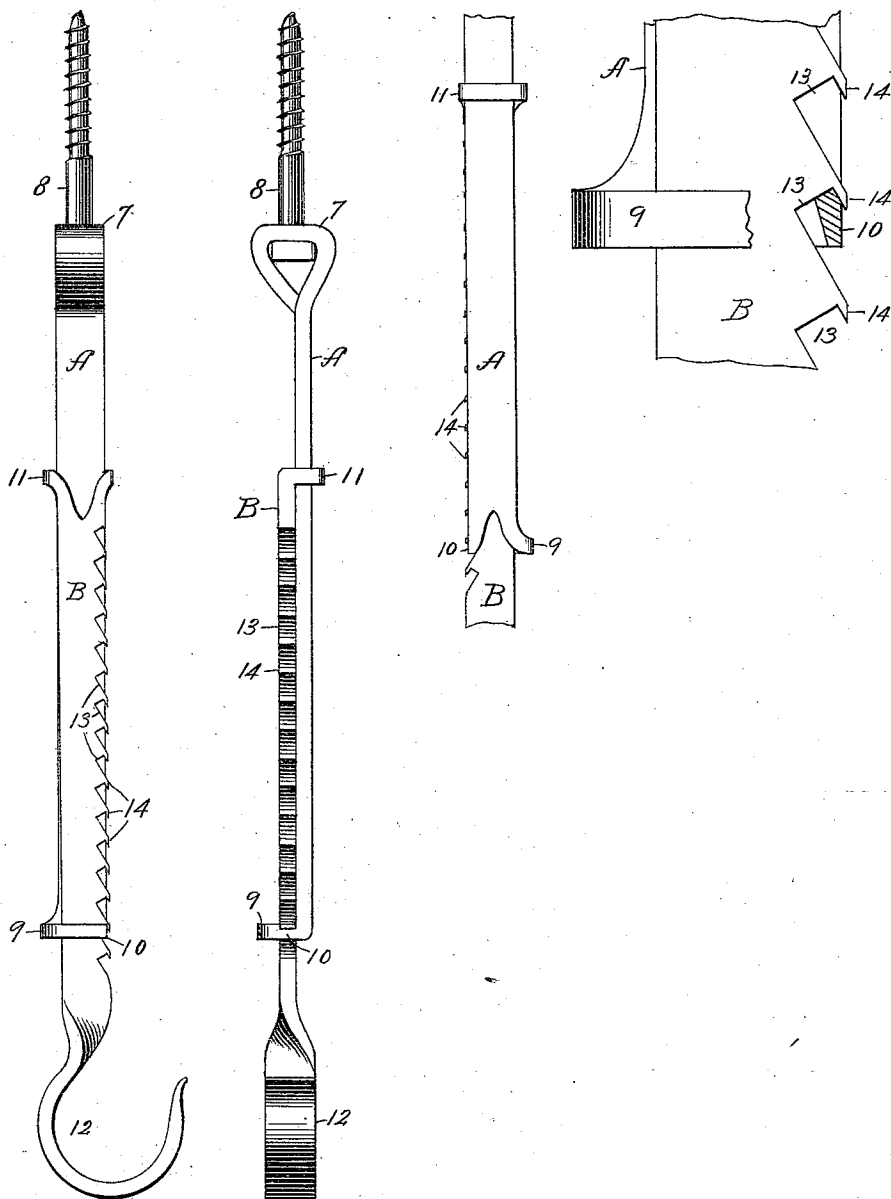

Witnesses

*Geo. E. Fisher*  
*W. D. Loomis pro*

Inventor

*Allen J. Beaton*  
*By James Shepard*  
*Atty.*

# UNITED STATES PATENT OFFICE.

ALLAN J. BEATON, OF SOUTHWINGTON, CONNECTICUT, ASSIGNOR TO THE  
BEATON & BRADLEY COMPANY, OF SAME PLACE.

## PIPE-HANGER.

SPECIFICATION forming part of Letters Patent No. 546,462, dated September 17, 1895.

Application filed January 22, 1895. Serial No. 535,831. (No model.)

*To all whom it may concern:*

Be it known that I, ALLAN J. BEATON, a citizen of the United States, residing at Southington, in the county of Hartford and State of Connecticut, have invented certain new and useful Improvements in Pipe-Hangers, of which the following is a specification.

My invention relates to improvements in pipe-hangers, and the chief object of my improvement is to provide an inexpensive and efficient hanger that can be very quickly and conveniently adjusted to different heights.

In the accompanying drawings, Figure 1 is a side elevation of my pipe-hanger. Fig. 2 is an edge view of the same. Fig. 3 is a side elevation of a portion of the same, showing the reverse side of that shown in Fig. 1. Fig. 4 is an enlarged side elevation of a portion of the same with the cross or end bar of the guiding-loop in section, the position of the parts corresponding with that shown in Fig. 1.

A designates the non-adjustable bar, which for convenience I will call the "fixed" bar, although its upper end is formed with a cross-arm 7, properly perforated to receive the bolt 8, by means of which the device may be fastened to any suitable overhead support, the joint thus formed between the bolt and upper end of the bar affording a slight swinging movement of the bar A, but not for the purpose of vertical adjustment. I prefer to employ a square-headed bolt and bend the metal at the upper end of the fixed bar A over its edges, as shown, so that turning the bar A will also turn the bolt *f* for screwing it into place. The bar A may be made of any desired length and is formed with a loop 9, the inner dimension of which is greater from side to side than the width of said bar. The cross or end bar 10 of the loop 9 is substantially flush with one edge of said bar A and the loop is made longer than the bar is wide by extending it beyond the opposite edge of said bar.

B designates the adjustable bar, having a loop 11 at its upper end, similar to the loop 9, and at its lower end a suitable hook or hanger 12 for receiving and holding the pipe. The parts are assembled with the body of the fixed bar passing loosely through the loop 11 of the adjustable bar and the body of the ad-

justable bar passing through the loop 9 of the fixed bar. One edge of one bar is provided with ratchet-teeth 13. In the particular form shown these teeth are on the adjustable bar, and consequently they are arranged with their shouldered or holding faces facing downwardly for engagement with the upper edge of the cross or end bar 10 of the loop 9. In addition to simple ratchet-teeth I prefer to provide the holding-face of each ratchet-tooth with a projecting lip 14, as shown, and to shape the upper edge of the cross or end bar 10 of the loop 9 in substantial conformity to the part of the ratchet-teeth on which it bears, as shown in Fig. 4. In the position shown the hook or hanger 12 is adjusted nearly as high as it can be. In order to lower it the adjustable bar is lifted a little, then moved edgewise in the direction to withdraw the ratchet-teeth from the cross or end bar 10 of the loop 9, bringing the opposite smooth edge of the bar against the opposite end of said loop, the loop being long enough so that the cross or end bar 10 will then be clear of the ratchet-teeth. The adjustable bar can then be lowered to any desired point, again moved edgewise to bring the bar 10 and ratchet-teeth into engagement, when the weight of the bar B and pipe will hold the parts in their adjusted position. In order to raise the hanger it is only necessary to push the hanger and adjustable bar upwardly to the desired point and then release it, the ratchet-teeth and gravity acting automatically to give the necessary edgewise movement for disengaging and engaging the ratchet-teeth and bar 10.

While it is obviously immaterial to the two interlocking bars and loops what the particular hook or pipe-hanger at the lower end or the fastening device at the upper end shall be, I have deemed it expedient to show a proper hook or pipe sustainer and one form of means for attaching to a suitable support, in order to show a complete article, although said parts of themselves are no part of my invention, and I wish it distinctly understood that any and every device or devices for performing like functions in connection with the parts which I have invented will be considered as equivalents therefor.

The middle portion of the hanger, between

the supporting-loop 7 and screw 8 and the hook 12, is of my invention and constitutes the essential feature thereof, and this portion I leave to the ordinary doctrine of equivalents and inversion of the parts.

I claim as my invention—

1. A pipe hanger having means for attaching to a suitable support and two bars and loops with the body of one bar passing through the loop of the other bar and vice versa, one of said bars being toothed on one edge, said teeth being adapted for engagement with the cross or end bar of the loop of the companion bar, the loop which coacts with said toothed edge being of a size to permit the necessary vibration for engagement and disengagement; one of said bars carrying a pipe sustainer,

substantially as described and for the purpose specified.

2. A pipe hanger provided with devices for sustaining a pipe and for attaching the hanger to a suitable support and having two bars and loops interlocking each other, one of said bars having at one edge the ratchet shaped teeth with the projection 14 on the holding face of said ratchet teeth, said bar and loops being relatively arranged for uniting and disuniting the interlocking loop and teeth, substantially as described and for the purpose specified.

ALLAN J. BEATON.

Witnesses:

JAMES SHEPARD,  
A. W. STIPEK.