



(22) Date de dépôt/Filing Date: 2011/12/30  
 (41) Mise à la disp. pub./Open to Public Insp.: 2012/07/05  
 (45) Date de délivrance/Issue Date: 2014/05/27  
 (30) Priorité/Priority: 2011/01/05 (US61/429,940)

(51) Cl.Int./Int.Cl. *A47L 9/26* (2006.01),  
*A47L 5/30* (2006.01), *A47L 9/04* (2006.01),  
*B65H 75/42* (2006.01)

(72) Inventeurs/Inventors:  
 MARSH, SAMUEL A., US;  
 FRY, MICHAEL L., US;  
 DANT, RYAN T., US;  
 HAWKINS, KYLE A., US;  
 PHEGLEY, SHANNON D., US;  
 STRECIWILK, ERIC J., US

(73) Propriétaire/Owner:  
 PANASONIC CORPORATION OF NORTH AMERICA,  
 US

(74) Agent: RICHES, MCKENZIE & HERBERT LLP

(54) Titre : ENSEMBLE SUCEUR COMPRENANT UN CORDON A ENROULEUR ET UN MOTEUR D'ENTRAINEMENT D'AGITATEUR

(54) Title: NOZZLE ASSEMBLY INCLUDING CORD REEL AND AGITATOR DRIVE MOTOR

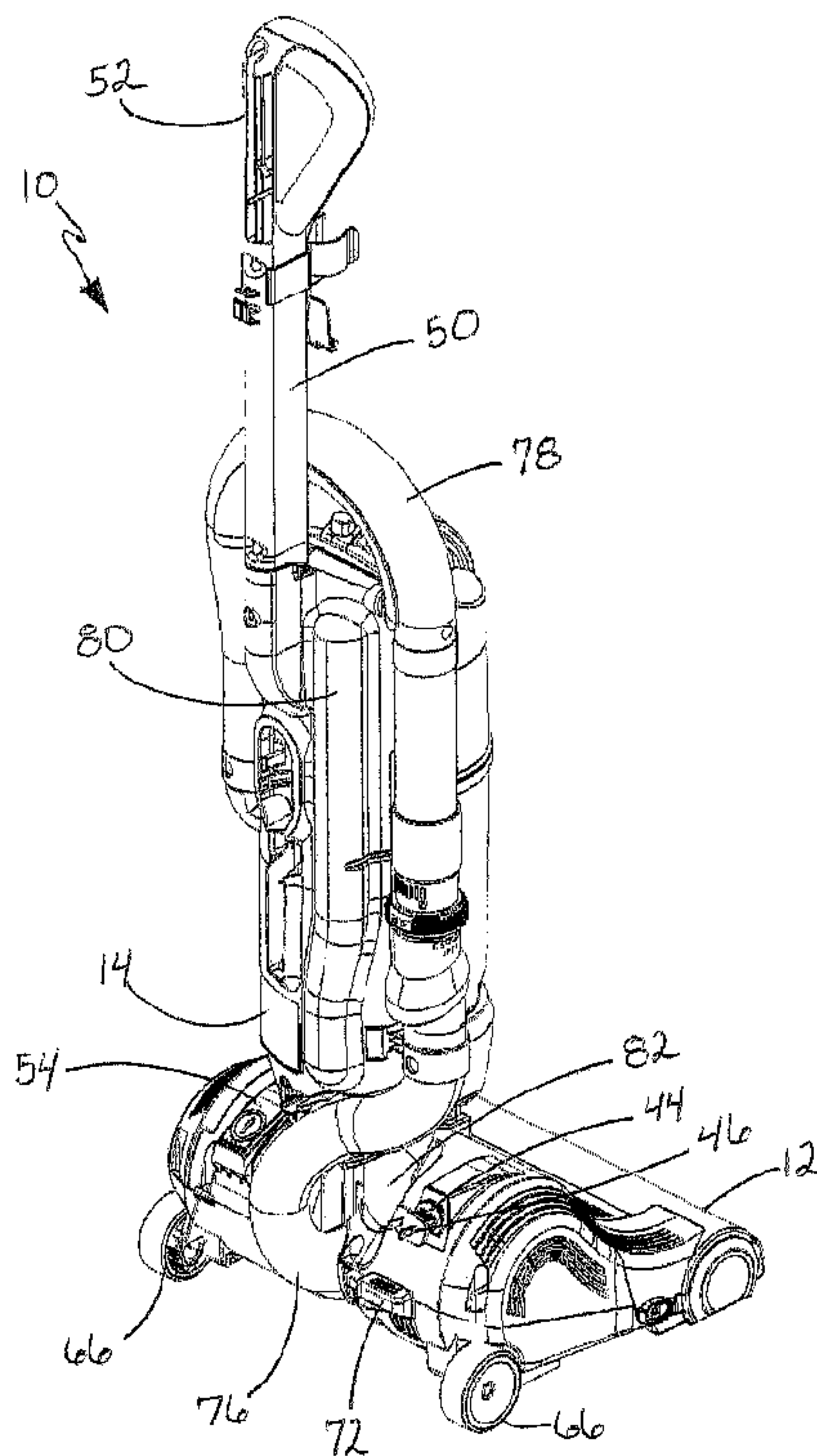

(57) **Abrégé/Abstract:**

A floor care apparatus includes a body having a nozzle assembly and a handle assembly. The handle assembly is pivotally attached to the nozzle assembly. Both a suction generator and a dirt collection vessel are carried on the body. A cord reel is carried on the nozzle assembly in a cord reel compartment. A rotary agitator drive motor is carried on the nozzle assembly in an airflow pathway which directs cooling air toward the cord reel in the cord reel compartment.



**ABSTRACT**

A floor care apparatus includes a body having a nozzle assembly and a handle assembly. The handle assembly is pivotally attached to the nozzle assembly. Both a suction generator and a dirt collection vessel are carried on the body. A cord reel is carried on the nozzle assembly in a cord reel compartment. A rotary agitator drive motor is carried on the nozzle assembly in an airflow pathway which directs cooling air toward the cord reel in the cord reel compartment.

## NOZZLE ASSEMBLY INCLUDING CORD REEL AND AGITATOR DRIVE MOTOR

TECHNICAL FIELD

[0001] The present invention relates generally to the floor care equipment field and, more particularly, to a floor care apparatus, such as an upright vacuum cleaner, incorporating a cord reel and agitator drive motor in the nozzle assembly.

BACKGROUND OF THE INVENTION

[0002] Floor care equipment such as upright vacuum cleaners and extractors, are well known in the art. An upright vacuum cleaner generally includes a body having both a nozzle assembly and a handle assembly. A suction generator and dirt collection vessel are both carried on the body. The nozzle assembly has a suction inlet and a rotary agitator that beats dirt and debris from the nap of an underlying carpet being cleaned. The handle assembly is pivotally connected to the nozzle assembly and is moved into an inclined position to allow the operator to guide the vacuum cleaner to and from across the floor.

[0003] Cord reel assemblies for vacuum cleaners are well known in the art. Such a cord reel assembly generally includes a reel upon which the electrical power cord of the apparatus is wound and stored. During use the operator unwinds the cord from the reel and connects the electrical plug to a standard electrical wall outlet. Following use the electrical plug is unplugged from the wall outlet and the cord is rewound on the reel for storage. U.S. Patent 5,023,410 to Danielson et al discloses one possible construction for a cord reel.

[0004] In the past the cord reel on an upright vacuum cleaner has been positioned on the pivoting handle assembly. This has been done for a number of reasons including the fact that the handle assembly has more room than the nozzle assembly to accommodate the cord reel and for operator convenience. An example of an upright vacuum cleaner equipped with a cord reel on

the handle assembly is found in U.S. Patent 5,168,598 to Hashizume et al. While such a cord reel is useful for its intended purpose, the positioning of the cord reel in the handle or canister assembly suffers from various drawbacks.

[0005] First, the weight of the cord reel in a handle assembly is positioned well above the center of gravity of the vacuum cleaner where it has a tendency to promote the inadvertent tipping over of the vacuum cleaner. Second, the opening on the handle assembly from which the electrical cord extends is positioned at a height well above the floor. In the event the electrical cord slips from the grasp of the operator, the spring loading of the reel which allows the rewinding of the cord onto the reel for storage may cause the free electrical cord to whip upwardly striking the operator.

[0006] The present invention relates to an upright vacuum cleaner equipped with a cord reel that is positioned in the nozzle assembly adjacent to ground. Thus, the cord reel is positioned closer to the floor where it will not promote potential tipping of the vacuum cleaner. Advantageously, this lowers the center of gravity of the vacuum cleaner thereby increasing its stability. In addition, by positioning the electrical cord payout opening closer to the ground, the potential of being struck above the knees by a free electrical cord during the rewinding operation is substantially reduced.

#### SUMMARY OF THE INVENTION

[0007] A floor care apparatus is provided comprising a body including a nozzle assembly and a handle assembly pivotally attached to the nozzle assembly. Both a suction generator and a dirt collection vessel are carried on the body. A cord reel is positioned in a cord reel compartment in the nozzle assembly. A rotary agitator is carried on the nozzle assembly in a rotary agitator cavity. In addition, a rotary agitator drive motor is carried on the nozzle assembly in an airflow pathway that directs cooling air toward the cord reel in the cord reel compartment.

[0008] More particularly describing the floor care apparatus, the cord reel compartment includes a cooling air inlet and a discharge outlet. Further, the nozzle assembly includes a suction generator compartment and the suction generator is held in the suction generator compartment. The suction generator compartment includes an exhaust port and the air flow

pathway extends from the exhaust port of the suction generator compartment to the cooling air inlet of the cord reel compartment. A filter covers the exhaust port of the suction generator compartment and clean air is circulated to provide cooling to the agitator drive motor and cord reel that are provided downstream from the filter.

[0009] The nozzle assembly includes a housing having a removable cover. Removal of the cover allows access to the air flow pathway including the agitator drive motor and the filter covering the exhaust port. The air flow pathway is positioned adjacent and parallel to the agitator cavity on the nozzle assembly. The housing and nozzle assembly also has a bottom plate and an electrical cord opening. An electrical power cord is wound on the cord reel and has an end that projects through the electrical cord opening. That electrical cord opening is provided no more than seventeen vertical centimeters above the bottom plate when the vacuum cleaner is positioned on a floor in an operating position.

[0009a] The present invention also provides a floor care apparatus, comprising: a body including a nozzle assembly and a handle assembly pivotally attached to said nozzle assembly; a suction generator carried on said body; a dirt collection vessel carried on said body; a rotary agitator carried on said nozzle assembly in a rotary agitator cavity; a cord reel carried on said nozzle assembly in a cord reel compartment; and a rotary agitator drive motor carried on said nozzle assembly in an airflow pathway directing cooling air exhausted from said suction generator toward said cord reel in said cord reel compartment.

#### BRIEF DESCRIPTION OF THE DRAWINGS

[0010] The accompanying drawings incorporated herein and forming a part of the specification, illustrate several aspects of the floor care apparatus and together with the description serve to explain certain principles of the device. In the drawings:

[0011] Figure 1 is a front elevation view of one possible embodiment of the floor care apparatus;

[0012] Figure 2 is a rear perspective view of the floor care apparatus illustrated in Figure 1;

[0013] Figure 3 is an exploded perspective view of the nozzle assembly of the floor care apparatus;

[0014] Figure 4 is a top plan view of the upright vacuum cleaner with the cover of the nozzle housing assembly removed to illustrate the positioning of the various internal components and the handle assembly in the inclined, use position;

**[0015]** Figure 5 is a detailed perspective view of the nozzle assembly with the cover removed to illustrate the internal structure including air flow pathways.

**[0016]** Reference will now be made in detail to the present preferred embodiment of the apparatus, an example of which is illustrated in the accompanying drawings.

DETAILED DESCRIPTION OF THE PREFERRED EMBODIMENTS OF THE INVENTION

[0017] Reference is now made to Figures 1-4 illustrating an upright vacuum cleaner 10. The upright vacuum cleaner 10 includes a body comprising a nozzle assembly 12 and a canister or handle assembly 14. The handle assembly 14 is pivotally connected to the nozzle assembly 12 by means of a twin pivot connector arm 18. The details of the connector arm 18 are not relevant to this discussion but can be found in co-pending U.S. Utility Patent Application Serial No. 13/223,615, filed on 1 September 2011.

[0018] As illustrated best in Figures 3 and 4, the nozzle assembly 12 includes an agitator cavity or suction inlet 20. A rotary agitator 22 is carried on the nozzle assembly 12 in the mouth of the suction inlet 20. The nozzle assembly 12 also includes a suction generator chamber 26 for receiving and holding the suction generator 28 and a cord reel chamber 30 for receiving and holding a cord reel 32. The suction generator 28 comprises a combined motor and fan assembly. The suction generator 28 functions to draw dirt and debris into and through the vacuum cleaner 10. A dedicated rotary agitator drive motor 29 functions to drive the rotary agitator 22 at the high speeds necessary to provide the desired cleaning action as the bristle tufts or other cleaning structures 24 on the rotary agitator sweep through the nap of an underlying carpet or rug being cleaned. In the illustrated embodiment, the agitator drive motor 29 is connected to the agitator 22 by means of the drive belt 31.

[0019] An electrical power cord 36 is wound onto the cord reel 32. As should be appreciated from viewing Figures 1, 2 and 5, the nozzle assembly 12 includes a housing 38 having a bottom plate 40, an agitator shield 41, a removable two-piece cover 42 and a resilient bumper 43. The suction inlet 20 is provided in the bottom plate 40. An electrical cord opening 44 is provided in the cover 42. The electrical power cord 36 extends or projects through the electrical cord opening 44. The plug 46 on the end of the electrical power cord 36 is larger than the opening 44 so as to always to be exposed for easy access by the operator. As should be appreciated, the electrical cord opening 44 is provided less than 17 vertical centimeters above the bottom plate 40 when the vacuum cleaner 10 is resting in an operating position on an underlying floor.

[0020] As best illustrated in Figure 4, the handle assembly 14 includes a control stalk 50 having a hand grip 52. In the illustrated embodiment, the switch 54 for controlling the operation of the suction generator 28 is provided on the nozzle assembly 12. A second switch 55 controls the operation of the agitator drive motor 29. However, it should be appreciated that either or both of the switches 54, 55 could be provided along the control stalk 50 adjacent to hand grip 52 if desired. The handle assembly 14 also carries a dirt collection vessel generally designated by reference numeral 56. In the illustrated embodiment the dirt collection vessel 56 comprises a reusable dirt cup 58. The dirt cup 58 may include a cylindrical sidewall 60, a tangentially directed inlet 62 and an axially directed outlet (not shown) covered by a filtering shroud 64 so as to provide cyclonic cleaning action. A primary filter (also not shown) may be provided in the dirt cup 58 or downstream from the dirt cup as desired. In an alternative embodiment, the dirt collection vessel 56 may comprise a vacuum cleaner filter bag of a type known in the art held in a filter bag compartment provided in the handle assembly 14.

[0021] The vacuum cleaner 10 is supported for movement along a floor on a series of wheels. More specifically, as illustrated in Figure 1 and 2, the nozzle assembly 12 carries a pair of rear wheels 66 and one or more forward wheels or rollers 68 that allow for height adjustment of the vacuum cleaner 10 with respect to the floor. Such height adjustment may be made by manipulating a height adjustment lever 70 that projects from the nozzle assembly 12 and is connected to a height adjustment mechanism (not shown) of a type known in the art. The lever 72 is depressed in order to release a lock that secures the handle assembly 14 in an upright storage position illustrated in Figures 1 and 2.

[0022] During vacuum cleaner 10 operation the rotary agitator 22 is driven by the dedicated agitator drive motor 29 and functions to beat dirt and debris from the nap of the underlying carpet. The suction generator 28 functions to draw a vacuum air stream into the suction inlet 20. Dirt and debris from the carpet is entrained in that air stream which is drawn by the suction generator 26 from the suction inlet 20 serially through the suction duct 74, flexible hose 76 and the conduit 78 into the tangentially directed inlet 62 of the dirt collection vessel 56. Dirt and debris are captured in the dirt collection vessel 56 while relatively clean air is drawn serially through an air stream conduit 80, the flexible hose 82 and the air stream conduit 84 into the



suction generator chamber 26. The air stream is then forced by the fan over the motor of the suction generator 28 so as to provide cooling. The air stream then passes through the exhaust port 86 of the suction generator chamber 26 and then through a final filter 88 covering that exhaust port. Next the air stream passes transversely across the nozzle assembly 12 through an air flow pathway 90. The agitator drive motor 29 is positioned in the airflow pathway 90 downstream from the filter 88 so that the clean airstream passes over the motor to provide cooling.

[0023] As best illustrated in Figures 4 and 5, the air flow pathway 90 directs the air stream from the exhaust port 86 of the suction generator chamber 26 into an inlet port 92 of the cord reel chamber 30. The air stream flows over the cord reel 32, any electrical cord 36 remaining wound on the cord reel and the electrical contacts (not shown) of the cord reel to provide cooling before being exhausted into the environment through the exhaust vent 94. It should be appreciated that an additional exhaust vent 96 may be provided in the cover 42 in direct communication with the air flow pathway 90. The vent 96 may be provided adjacent the agitator drive motor 29. Thus, while one portion of the air stream (the portion that provides most of the cooling to the agitator drive motor 29) is vented through the exhaust vent 96 directly from the air flow pathway 90 into the ambient environment, another portion of the air stream flows through the cord reel chamber 30 over the cord reel 32 to provide cooling before being vented through the exhaust vent 94 into the ambient environment. The vent 96 also relieves any back pressure that might otherwise reduce the suction power and cleaning efficiency of the vacuum cleaner 10. The vent 96 may comprise one opening or a series of openings in the cover 42 adjacent the motor 29 or all along the length of the airflow pathway 90 as well as substantially any other configuration.

[0024] As best illustrated in Figures 4 and 5, it should be appreciated that the air flow pathway 90 extends transversely across the nozzle assembly 12 between the (a) the suction generator and cord reel chambers 26, 30 on a first side and (b) the suction inlet 20 on a second side. Further, the air flow pathway 90 crosses over the suction duct 74 that is connected to the suction inlet 20. The removable cover 42 allows one to easily access the final filter 88 and the agitator drive motor 29 in the airflow pathway 90 should either ever need service.

[0025] In summary, numerous benefits result in employing the concepts disclosed in this document. Specifically, the cord reel chamber 32 is provided at the rear of the nozzle assembly 12 on one side of the handle mount or connector arm 18 while the suction generator 28 is mounted at the rear of the nozzle assembly on the opposite side thereof. As should be appreciated the cord reel 32 has a first axis of rotation  $R_1$  and the rotary agitator 22 has a second axis of rotation  $R_2$  where the axis of rotation are provided parallel to one another. The air flow pathway 90 extends transversely across the nozzle assembly 12 between the suction generator and cord reel chambers 26, 30 on the one side and the suction inlet 20 on the other side where it can provide sufficient space for receiving the final filter 88 while still maintaining a compact design. Further, the front portion of the nozzle assembly 12 still maintains a low profile for cleaning under cabinets and along the toe plates thereof and the like.

[0026] Advantageously, the positioning of the cord reel 32 in the nozzle assembly 12 rather than the handle assembly 14 as in previous upright vacuum cleaner designs removes weight from the handle assembly and places it lower to the ground thereby increasing the stability of the vacuum cleaner 10. Further, by placing the electrical cord opening 44 in the nozzle assembly cover 42 within 17 or fewer centimeters of the bottom plate 40, the electrical cord 36 and plug 46 are placed in a convenient rearwardly facing orientation (i.e. in a direction facing away from the suction inlet 20) where the plug may be conveniently accessed by the operator. Further, if the operator inadvertently drops the end of the cord 36 as it is being retracted by the cord reel 32 into the nozzle assembly 12, the cord is positioned low where it has the least potential to strike the operator.

[0027] The foregoing description of the preferred embodiment of the present device has been presented for purposes of illustration and description. It is not intended to be exhaustive or to limit the device to the precise form disclosed. Obvious modifications or variations are possible in light of the above teachings. The embodiments were chosen and described to provide the best illustration of the principles of the device and its practical application to thereby enable one of ordinary skill in the art to utilize the device in various embodiments and with various modifications as are suited to the particular use contemplated. All such modifications and variations are within the scope of the device as determined by the appended claims when

interpreted in accordance with the breadth to which they are fairly, legally and equitably entitled. The drawings and preferred embodiments do not and are not intended to limit the ordinary meaning of the claims in their fair and broad interpretation in any way.

**We Claim:**

1. A floor care apparatus, comprising:
  - a body including a nozzle assembly and a handle assembly pivotally attached to said nozzle assembly;
  - a suction generator carried on said body;
  - a dirt collection vessel carried on said body;
  - a rotary agitator carried on said nozzle assembly in a rotary agitator cavity;
  - a cord reel carried on said nozzle assembly in a cord reel compartment; and
  - a rotary agitator drive motor carried on said nozzle assembly in an airflow pathway directing cooling air exhausted from said suction generator toward said cord reel in said cord reel compartment.
2. The apparatus of claim 1, wherein said cord reel compartment includes a cooling air inlet and a discharge outlet.
3. The apparatus of claim 2, wherein said nozzle assembly includes a suction generator compartment and said suction generator is held in said suction generator compartment.
4. The apparatus of claim 3, wherein said suction generator compartment includes an exhaust port and said airflow pathway extends from said exhaust port of said suction generator compartment to said cooling air inlet of said cord reel compartment.
5. The apparatus of claim 4, further including a filter covering said exhaust port of said suction generator compartment.
6. The apparatus of claim 5, wherein said nozzle assembly includes a housing having a removable cover whereby said cover is removed to access said airflow pathway including said agitator drive motor and said filter covering said exhaust port.
7. The apparatus of claim 6, wherein said airflow pathway is adjacent and parallel to said agitator cavity.

8. The apparatus of claim 7, wherein said nozzle assembly includes a suction inlet in fluid communication with said agitator cavity and said airflow pathway crosses said suction inlet.
9. The apparatus of claim 3, further including a handle mount pivot carried on said nozzle assembly, said handle mount pivot being positioned between said cord reel compartment and said suction generator compartment.
10. The apparatus of claim 9, wherein said cord reel compartment, said handle mount and said suction generator compartment are all provided on a first side of said airflow pathway while said agitator cavity is provided on a second side of said airflow pathway.
11. The apparatus of claim 1, wherein said nozzle assembly includes a housing having a bottom plate and an electrical cord opening.
12. The apparatus of claim 11, further including an electrical power cord wound on said cord reel and having an end projecting through said electrical cord opening.
13. The apparatus of claim 12, wherein said electrical cord opening is provided no more than 17 vertical centimeters above said bottom plate when said vacuum cleaner is positioned on a floor in an operating position.
14. The apparatus of claim 13, wherein said electrical cord opening opens rearwardly away from said agitator cavity.
15. The apparatus of claim 11, wherein a first vent is provided in said housing in communication with said airflow pathway and a second vent is provided in said housing in communication with said cord reel compartment, whereby a first portion of an airstream from said suction generator passes over said agitator drive motor before being exhausted from said first vent directly from said airflow pathway into ambient air while a second portion of said airstream from said suction generator is passed over said cord reel to provide cooling before being exhausted from said second vent directly from said cord reel compartment into ambient air.

FIG. 1

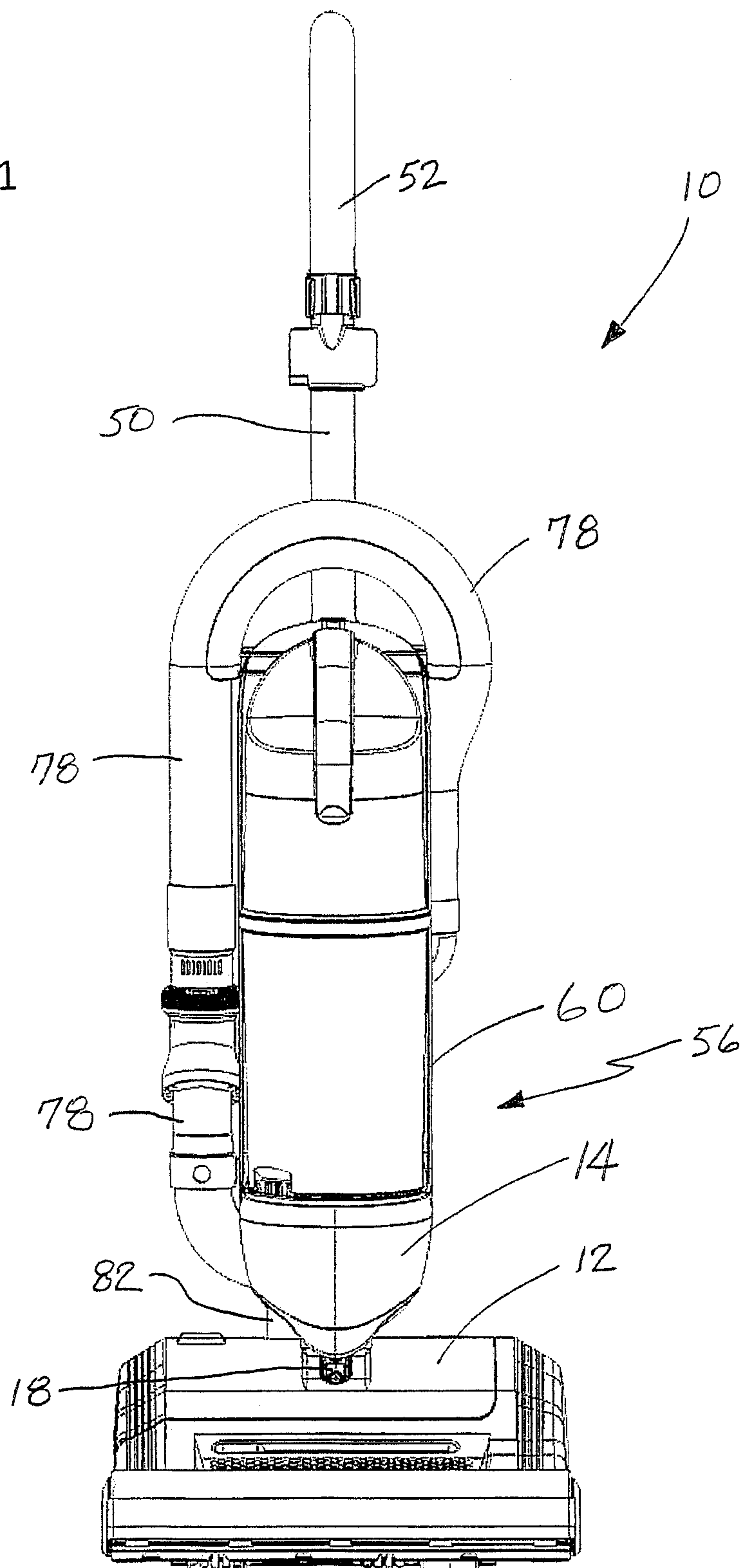

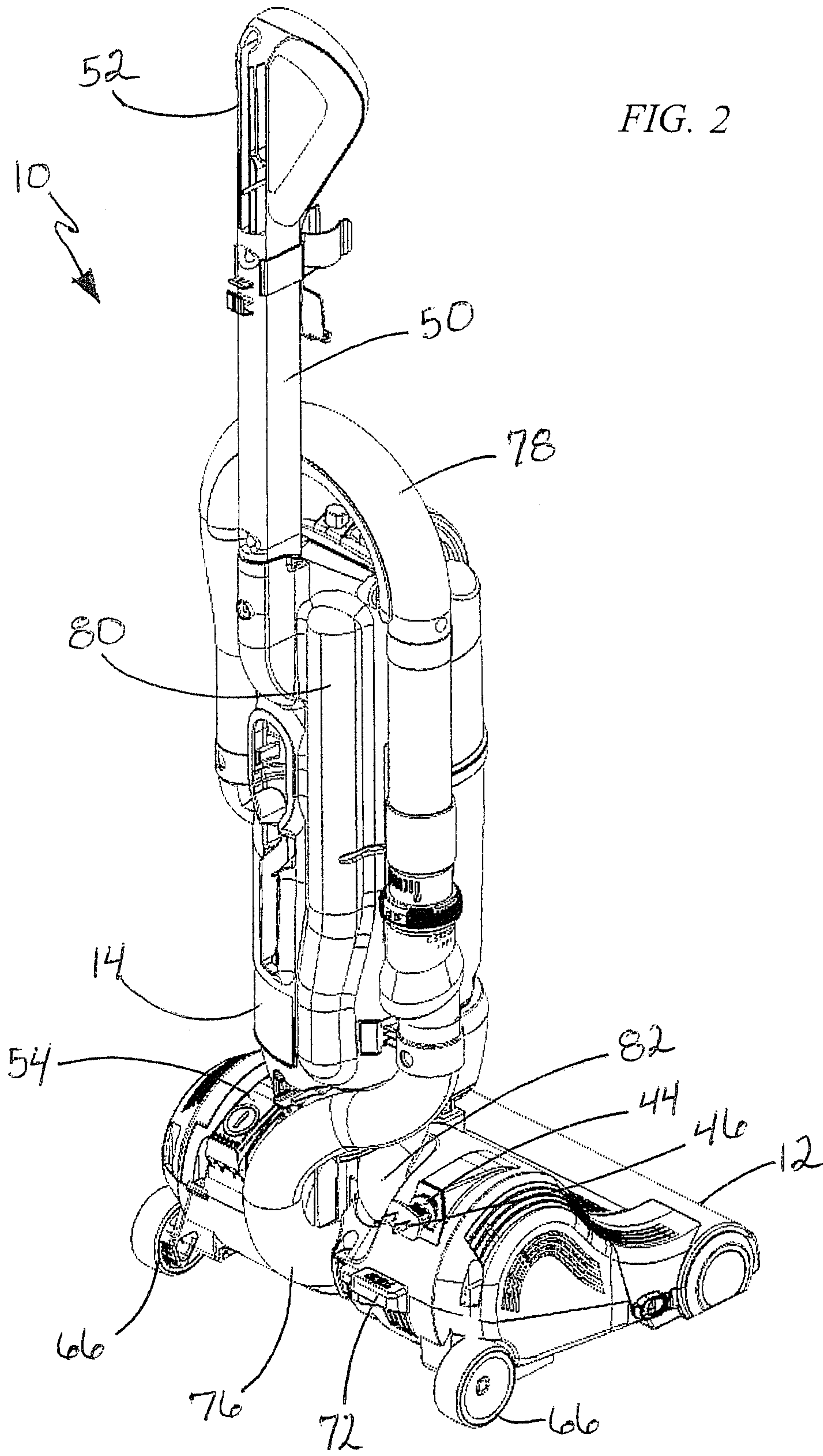

FIG. 2

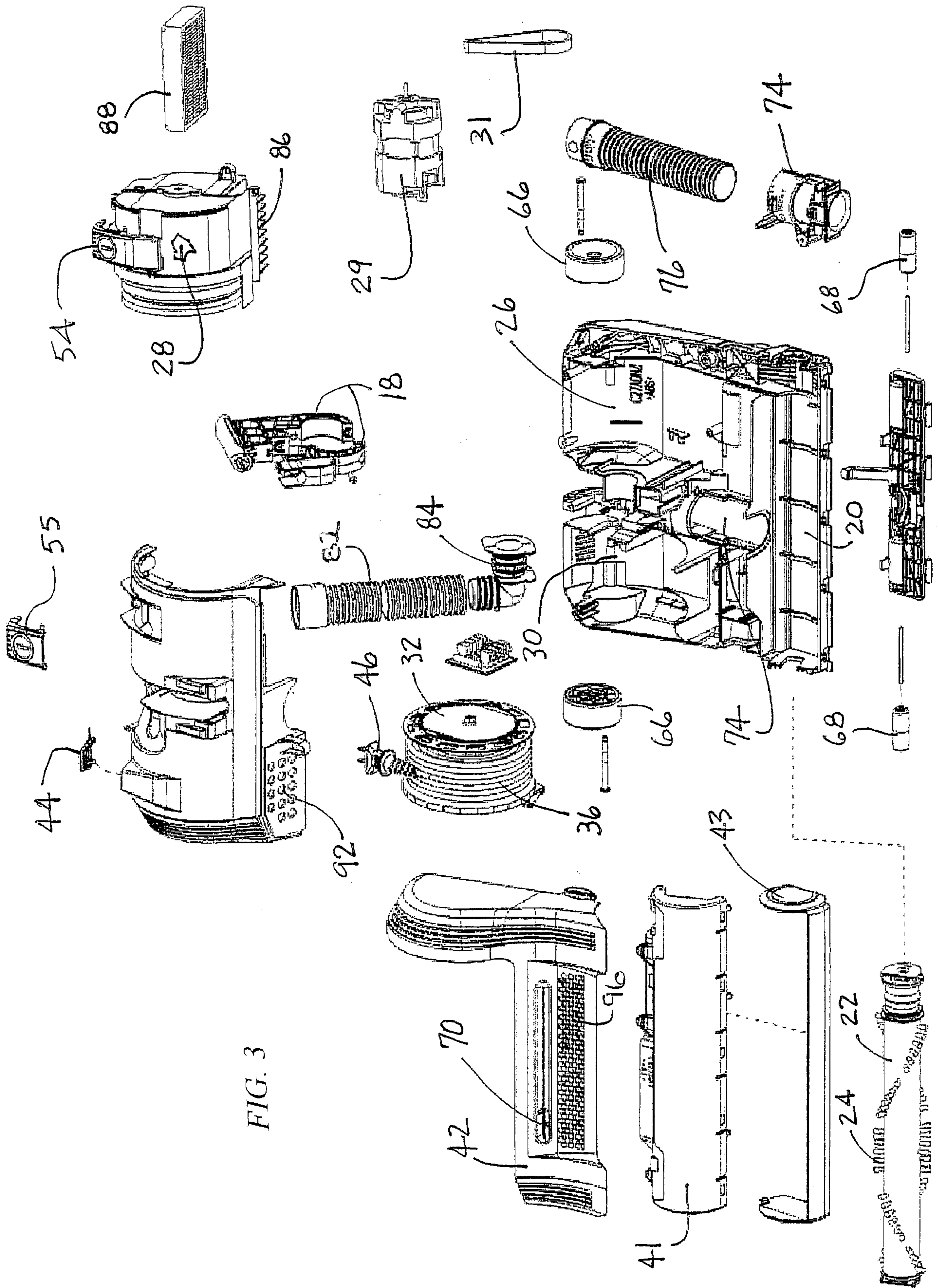
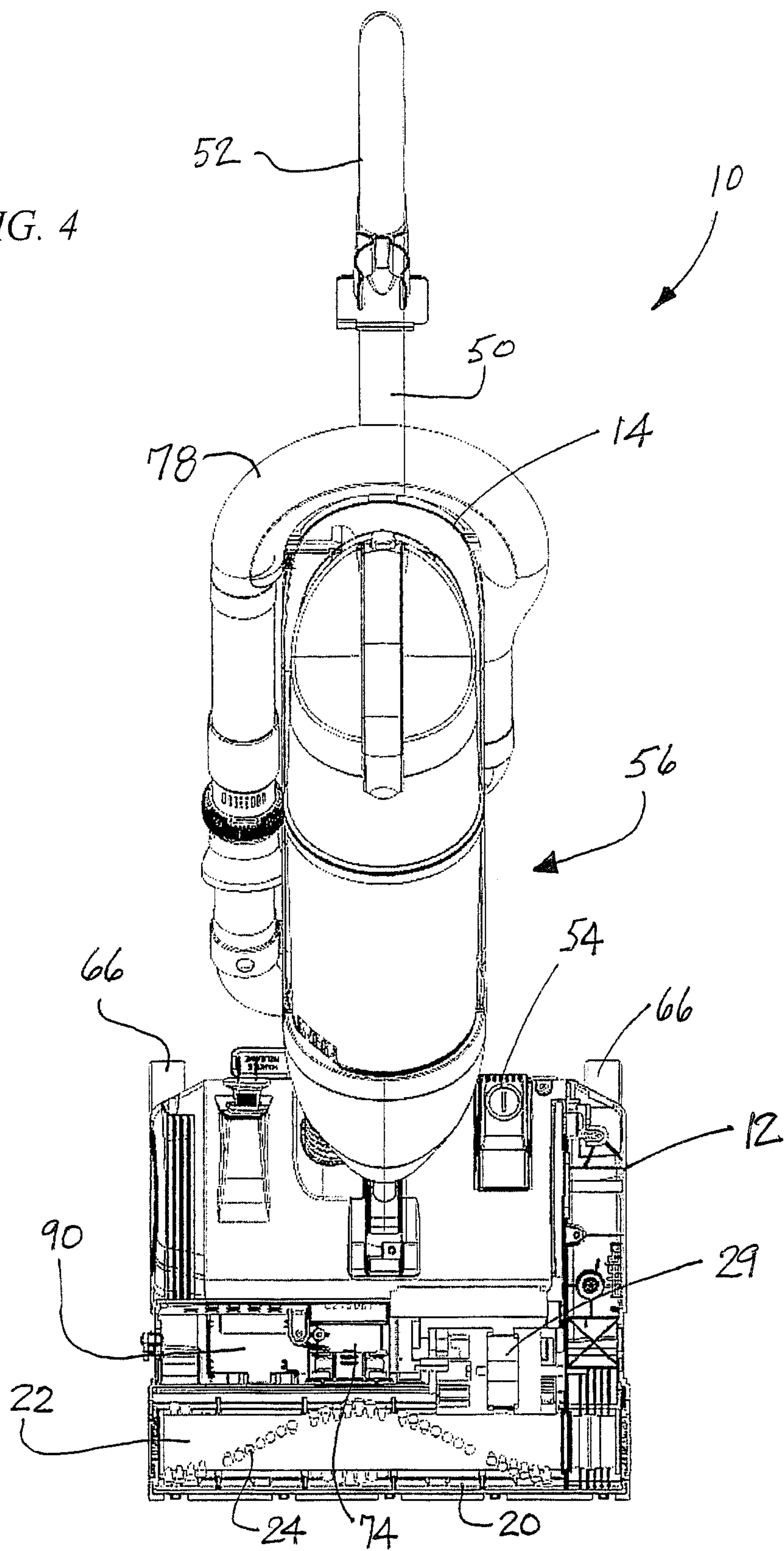

FIG. 3



FIG. 4



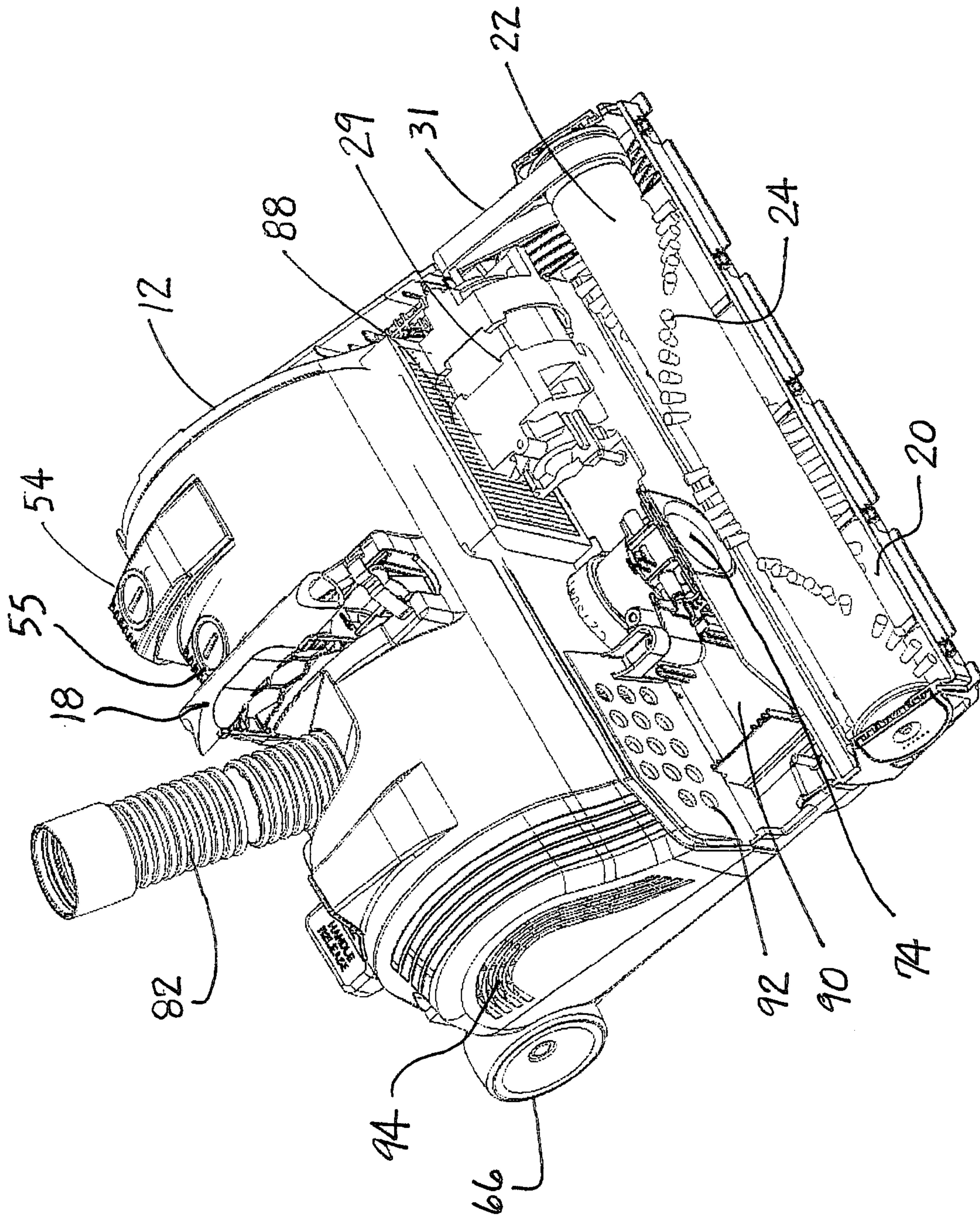

FIG. 5

