



US00D836137S

(12) **United States Design Patent**
Stanley et al.

(10) **Patent No.:** **US D836,137 S**

(45) **Date of Patent:** **** Dec. 18, 2018**

(54) **LAND CLEARING TOOL INTERFACE**

OTHER PUBLICATIONS

(71) Applicant: **Fecon, Inc.**, Lebanon, OH (US)

International Search Report and Written Opinion received for International Application No. PCT/US2009/034872, dated Apr. 21, 2009, 8 pages.

(72) Inventors: **Jeffrey T. Stanley**, Lebanon, OH (US);
Steven K. Watson, III, West Chester, OH (US)

(Continued)

(73) Assignee: **Fecon, Inc.**, Lebanon, OH (US)

Primary Examiner — Mark A Goodwin

(74) *Attorney, Agent, or Firm* — Ulmer & Berne LLP

(**) Term: **15 Years**

(21) Appl. No.: **29/591,850**

(57) **CLAIM**

The ornamental design for a land clearing tool interface, as shown and described.

(22) Filed: **Jan. 24, 2017**

(51) **LOC (11) Cl.** **15-03**

(52) **U.S. Cl.**

USPC **D15/28**

(58) **Field of Classification Search**

USPC D15/20, 21, 28, 29; 172/548, 540, 122,
172/554; 241/294, 242, 300, 189, 194,
241/195; 37/454, 453, 456, 452;
404/121, 235, 24.12, 34.1, 4.1; 144/241,
144/235, 24.12, 34.1, 4.1; 83/840;
56/13.6

CPC E02F 9/2833; E02F 9/2841; E02F 9/28;
B02C 18/18; B02C 18/16; B02C 18/14;
B02C 18/06; B02C 18/146; B02C 18/184;
B02C 18/145; B02C 1/10

See application file for complete search history.

DESCRIPTION

FIG. 1 is a front perspective view of a land clearing tool interface showing our new design; FIG. 2 is a front elevation view thereof; FIG. 3 is a rear elevation view thereof; FIG. 4 is a right side elevation view thereof; FIG. 5 is a left side elevation view thereof; FIG. 6 is a top plan view thereof; FIG. 7 is a bottom plan view thereof; FIG. 8 is a rear perspective view thereof; FIG. 9 is a front perspective view of another embodiment of the land clearing tool interface showing our new design; FIG. 10 is a front elevation view thereof; FIG. 11 is a rear elevation view thereof; FIG. 12 is a right side elevation view thereof; FIG. 13 is a left side elevation view thereof; FIG. 14 is a top plan view thereof; FIG. 15 is a bottom plan view thereof; and, FIG. 16 is a rear perspective view thereof.

The dashed broken lines in FIGS. 1-16 represent portions of the land clearing tool interface that form no part of the claimed design.

The line shading in FIGS. 1-16 represents contour and not surface ornamentation.

(56) **References Cited**

U.S. PATENT DOCUMENTS

833,797 A 10/1906 Ollrich
1,905,384 A 4/1933 Jass
2,131,947 A 10/1938 Gilmore
2,242,808 A 5/1941 Austin
2,560,413 A 7/1951 Carlson

(Continued)

FOREIGN PATENT DOCUMENTS

FR 2866909 A1 9/2005
WO 2009105752 A2 8/2009

1 Claim, 16 Drawing Sheets

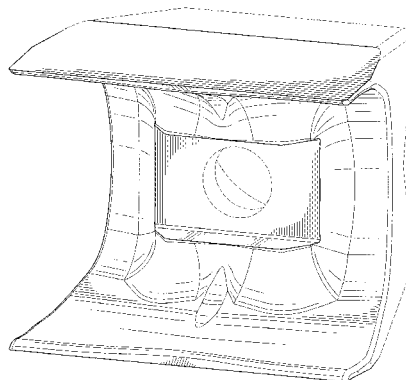

(56)

References Cited

U.S. PATENT DOCUMENTS

3,049,824 A 8/1962 McIninch
 3,203,488 A 8/1965 Eastwood
 3,274,908 A 9/1966 Grant et al.
 3,277,802 A 10/1966 Petersen
 3,358,569 A 12/1967 Averette
 3,490,117 A * 1/1970 Hertel B23B 27/1614
 407/101
 3,642,214 A 2/1972 Blackwell
 3,774,324 A 11/1973 LaFond
 3,837,408 A 9/1974 Green
 3,850,375 A 11/1974 Ford
 4,231,406 A 11/1980 Jonsson
 4,329,091 A 5/1982 Erkfritz
 4,667,713 A 5/1987 Wright
 4,668,122 A 5/1987 Riddle
 4,682,916 A 7/1987 Briese
 4,709,737 A 12/1987 Jonsson
 4,727,664 A 3/1988 Hemphill
 4,782,774 A 11/1988 Clarke
 4,813,491 A 3/1989 Gross
 4,826,090 A 5/1989 Orphall
 4,842,337 A 6/1989 Southern
 4,891,858 A 1/1990 Wachter
 4,918,843 A 4/1990 Kiesewetter et al.
 4,919,566 A 4/1990 Caron et al.
 4,932,447 A 6/1990 Morin
 H946 H 8/1991 Lonn
 5,077,918 A 1/1992 Garman
 5,211,212 A 5/1993 Carlson et al.
 5,259,692 A 11/1993 Beller et al.
 5,423,138 A 6/1995 Livesay et al.
 5,484,110 A 1/1996 Doppstadt
 5,503,339 A 4/1996 Doppstadt
 5,644,965 A 7/1997 MacLennan et al.
 5,873,534 A 2/1999 Shinn
 5,875,980 A 3/1999 Schmid
 6,024,143 A 2/2000 Ritchey
 6,045,072 A 4/2000 Zehr
 6,047,749 A 4/2000 Lamb
 D424,076 S 5/2000 Dibbern et al.
 6,059,373 A 5/2000 Wright et al.
 6,089,480 A 7/2000 Rawlings
 D435,571 S 12/2000 Dibbern et al.
 6,176,445 B1 1/2001 Shinn
 6,193,430 B1 2/2001 Culpepper et al.
 6,247,757 B1 6/2001 Cochran
 D446,224 S 8/2001 Clendenning
 D447,154 S 8/2001 Clendenning
 6,394,378 B1 5/2002 Ragnarsson
 6,422,495 B1 7/2002 De Boef et al.
 6,435,434 B1 8/2002 Monyak
 6,502,609 B1 1/2003 Guels
 6,517,274 B1 2/2003 Watanabe et al.
 6,536,322 B1 3/2003 Butler et al.
 6,682,262 B2 1/2004 Caron et al.
 D486,503 S 2/2004 East
 6,708,431 B2 3/2004 Robinson et al.

6,712,551 B2 3/2004 Livesay et al.
 D488,174 S 4/2004 East
 6,725,758 B2 4/2004 MacLennan et al.
 6,764,035 B2 7/2004 Denis et al.
 6,810,783 B1 11/2004 Larose
 6,837,453 B2 1/2005 Sturm
 7,108,452 B2 9/2006 Caron et al.
 7,150,215 B2 12/2006 Krehel
 7,222,808 B2 5/2007 Edwards
 7,278,462 B2 10/2007 Purdy et al.
 7,281,676 B1 10/2007 Bennington
 D567,832 S 4/2008 Edwards
 7,380,576 B2 6/2008 Pizzuto
 7,448,567 B2 11/2008 Roozeboom et al.
 7,578,462 B2 8/2009 Edwards
 7,584,921 B1 9/2009 Bennington et al.
 7,634,897 B2 12/2009 MacLennan et al.
 7,713,006 B2 5/2010 MacLennan et al.
 7,810,531 B2 10/2010 Labbé
 7,828,026 B2 11/2010 MacLennan et al.
 7,913,432 B2 3/2011 MacLennan et al.
 7,938,350 B2 5/2011 Doppstadt et al.
 7,967,044 B2 6/2011 Labbe et al.
 7,980,278 B2 7/2011 Labbe et al.
 D647,928 S 11/2011 MacLennan et al.
 8,167,225 B2 5/2012 Gaudreault
 8,540,033 B2 9/2013 Stanley et al.
 8,550,391 B2 * 10/2013 Denis A01G 23/00
 241/294
 8,807,868 B2 8/2014 Schlenker et al.
 8,893,997 B2 11/2014 Gaudreault
 D757,124 S 5/2016 Stanley et al.
 D772,951 S 11/2016 Stanley et al.
 D791,195 S 7/2017 Stanley et al.
 D795,929 S 8/2017 Stanley et al.
 D795,931 S 8/2017 Stanley et al.
 2002/0190148 A1 12/2002 Roozeboom et al.
 2003/0192299 A1 10/2003 Kaga et al.
 2004/0016153 A1 1/2004 Pippins
 2005/0001084 A1 1/2005 Pizzuto
 2005/0098331 A1 5/2005 Edwards
 2006/0272183 A1 12/2006 Kergen
 2007/0193428 A1 8/2007 MacLennan et al.
 2007/0261762 A1 11/2007 Eriksson
 2008/0283257 A1 11/2008 Edwards
 2009/0014189 A1 1/2009 Stanley et al.
 2010/0180735 A1 7/2010 MacLennan et al.
 2011/0100658 A1 5/2011 Stanley et al.
 2012/0032013 A1 2/2012 Rice et al.
 2013/0099039 A1 4/2013 Gaudreault
 2016/0278298 A1 9/2016 Stanley et al.
 2017/0079219 A1 3/2017 Stanley et al.

OTHER PUBLICATIONS

International Preliminary Report on Patentability received for International Application No. PCT/US2009/034872, dated Aug. 24, 2010, 7 pages.

* cited by examiner

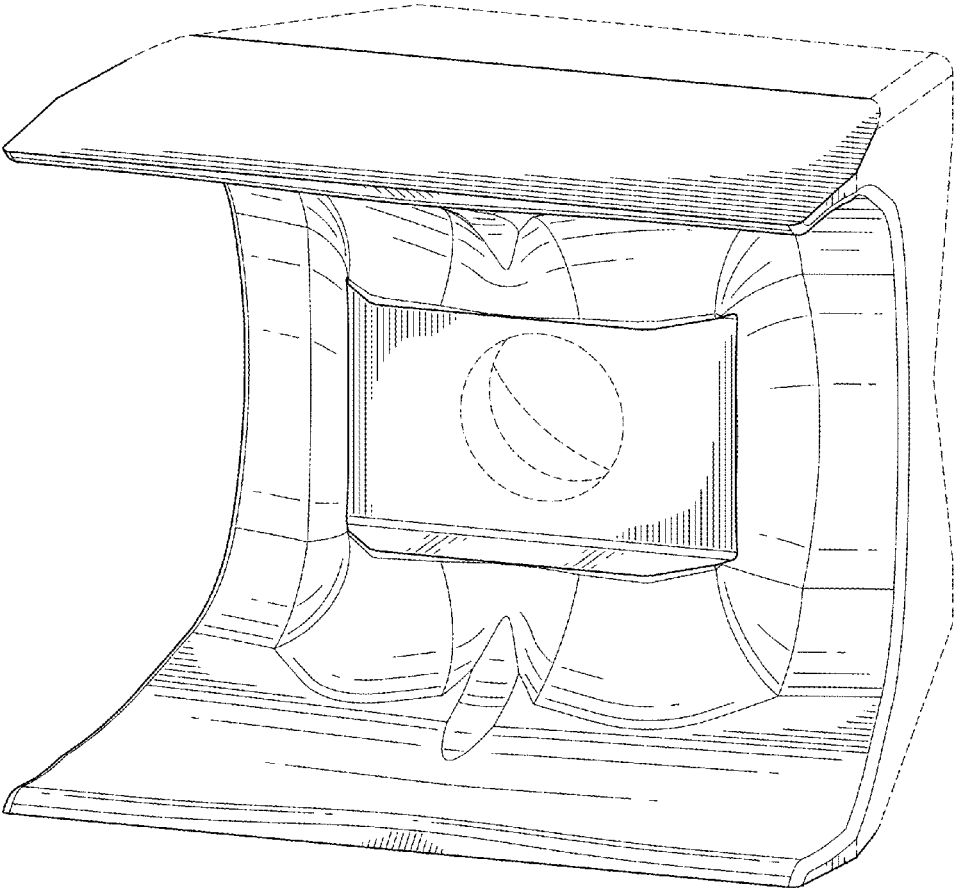

FIG. 1

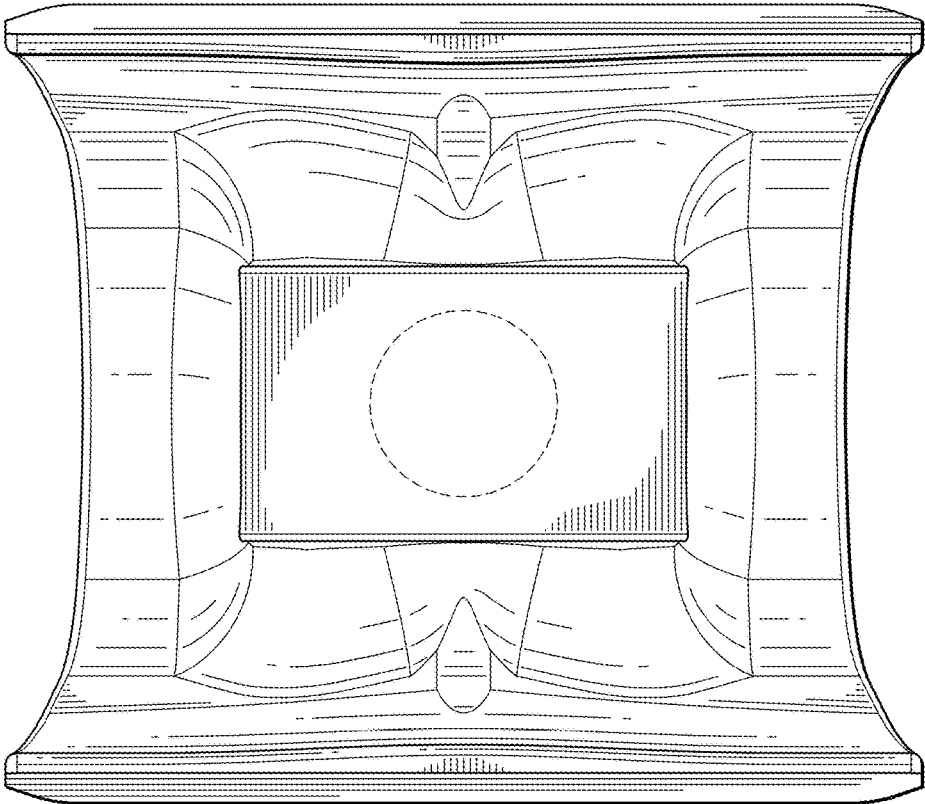

FIG. 2

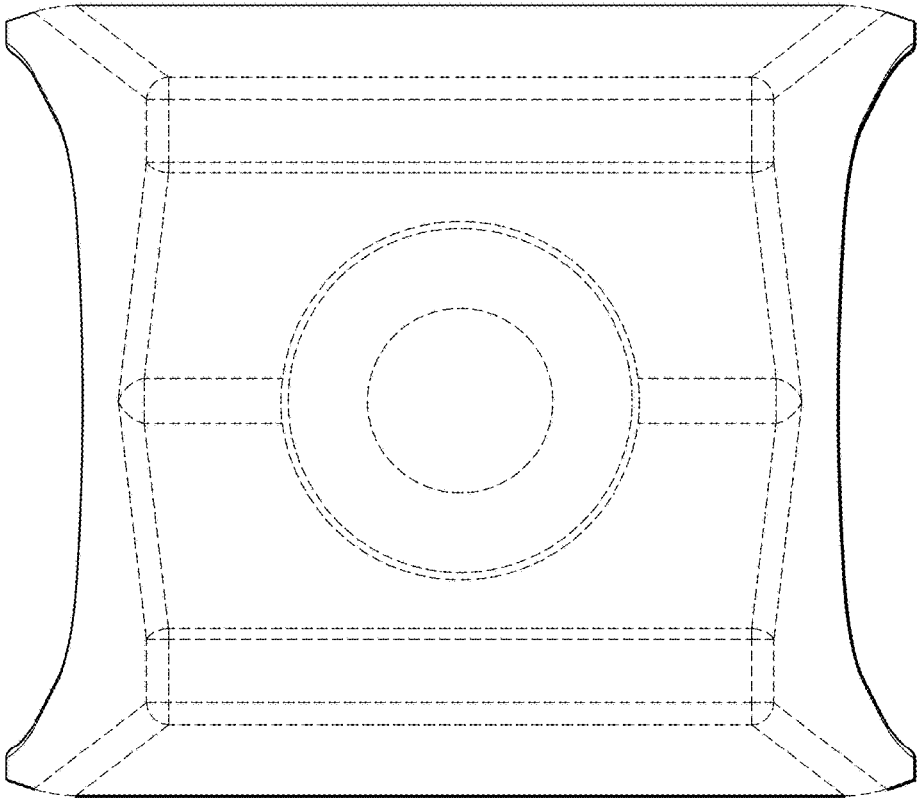

FIG. 3

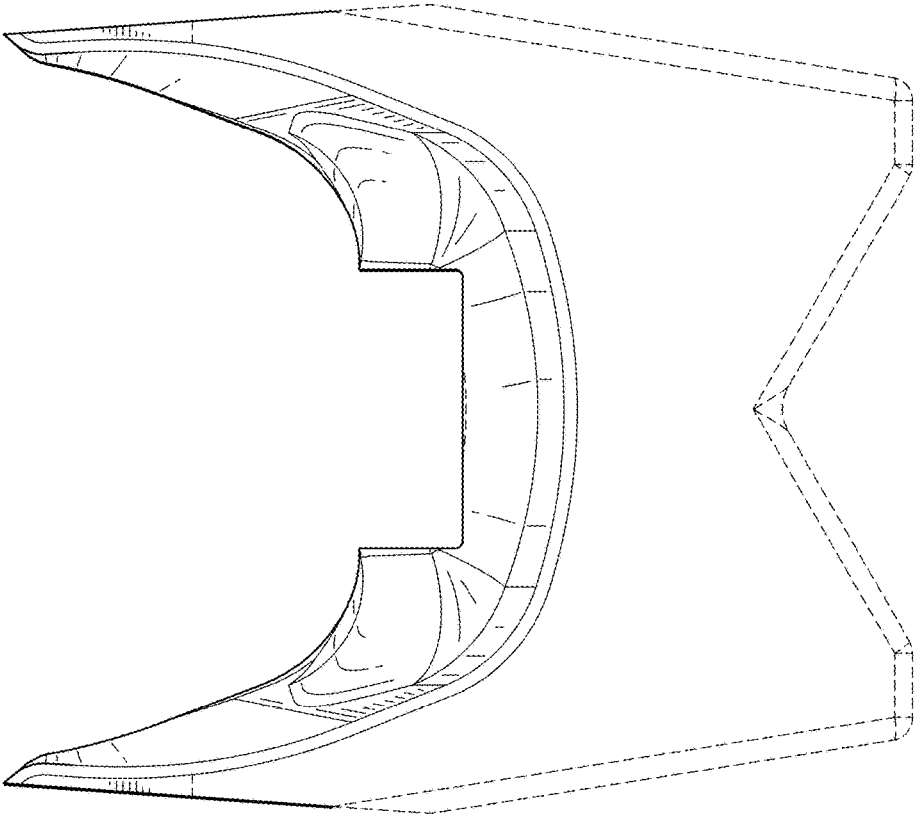

FIG. 4

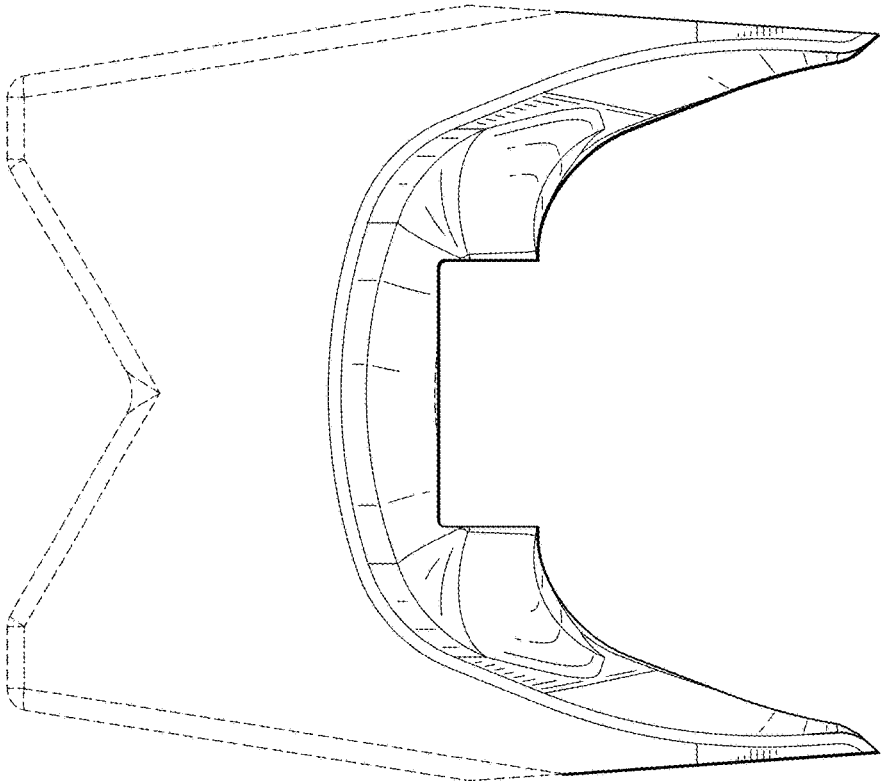

FIG. 5

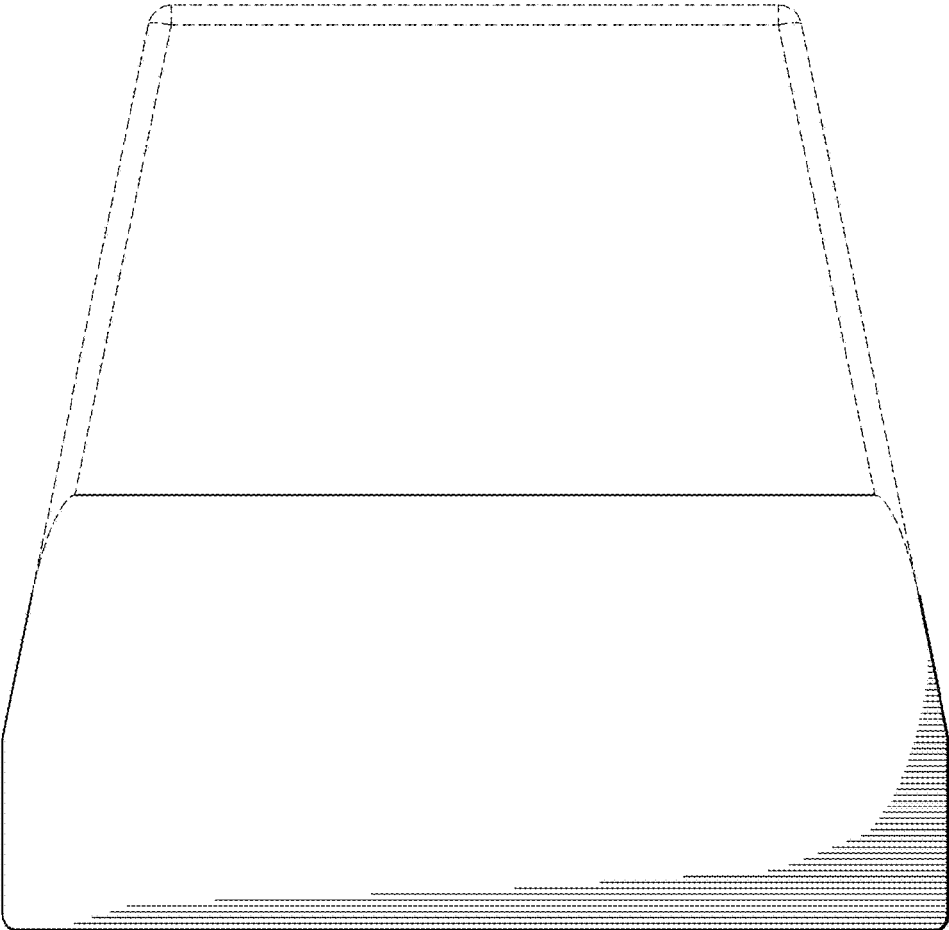

FIG. 6

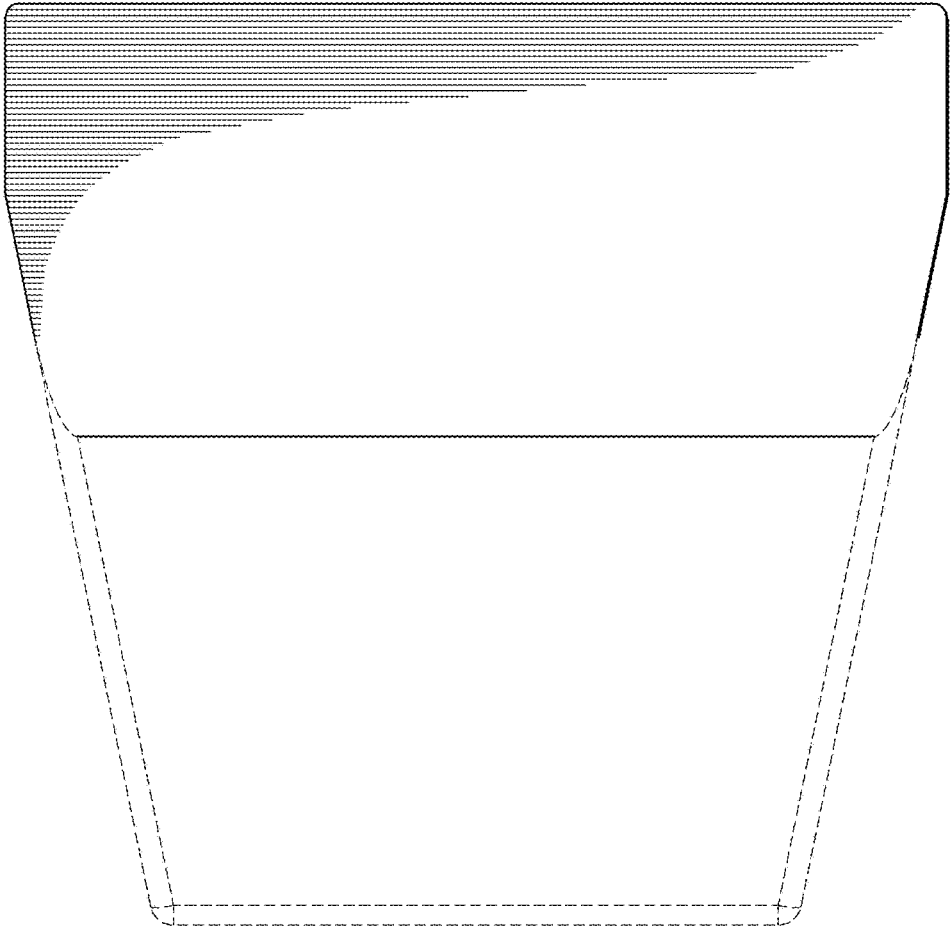

FIG. 7

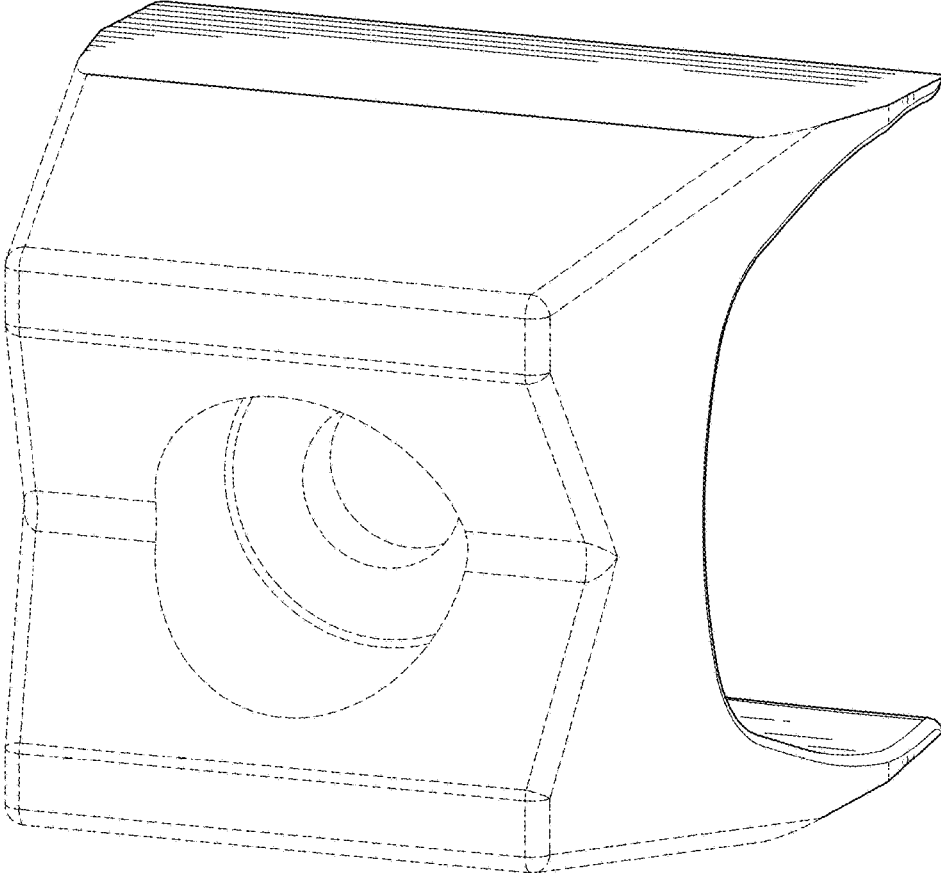

FIG. 8

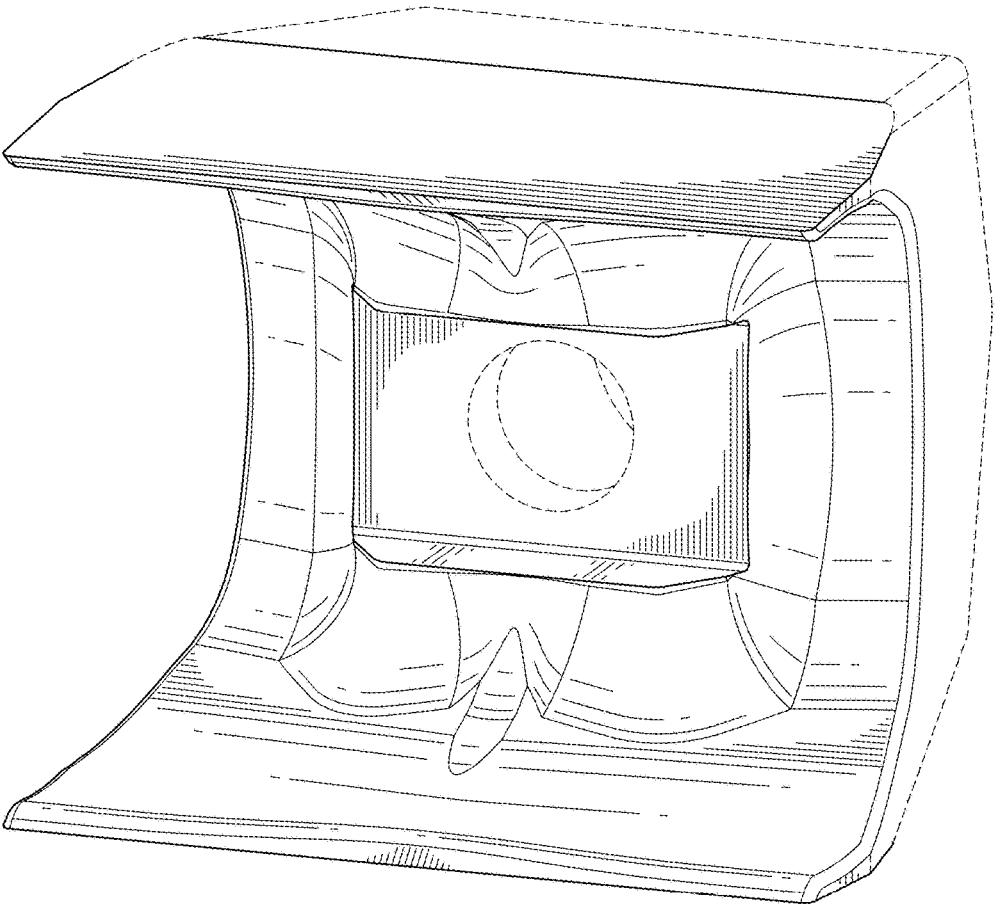

FIG. 9

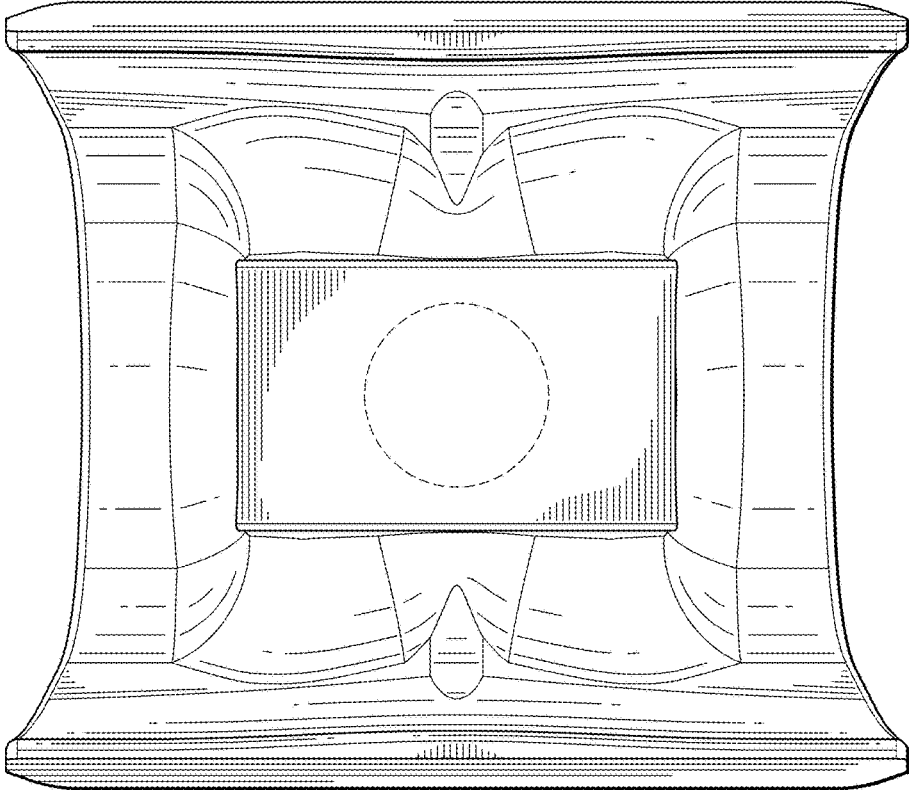

FIG. 10

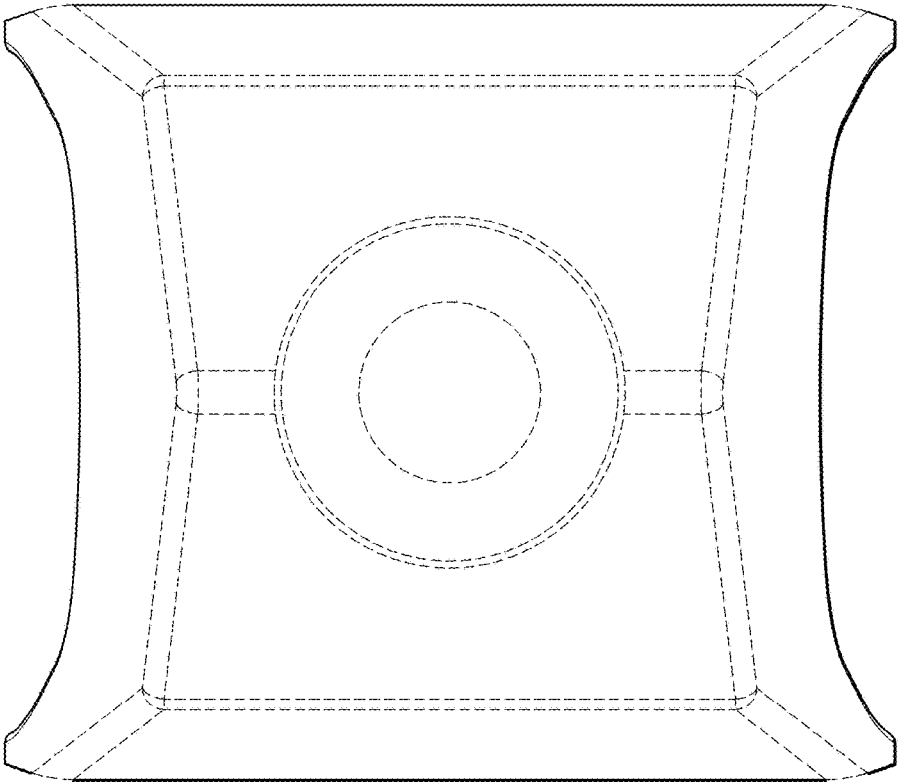

FIG. 11

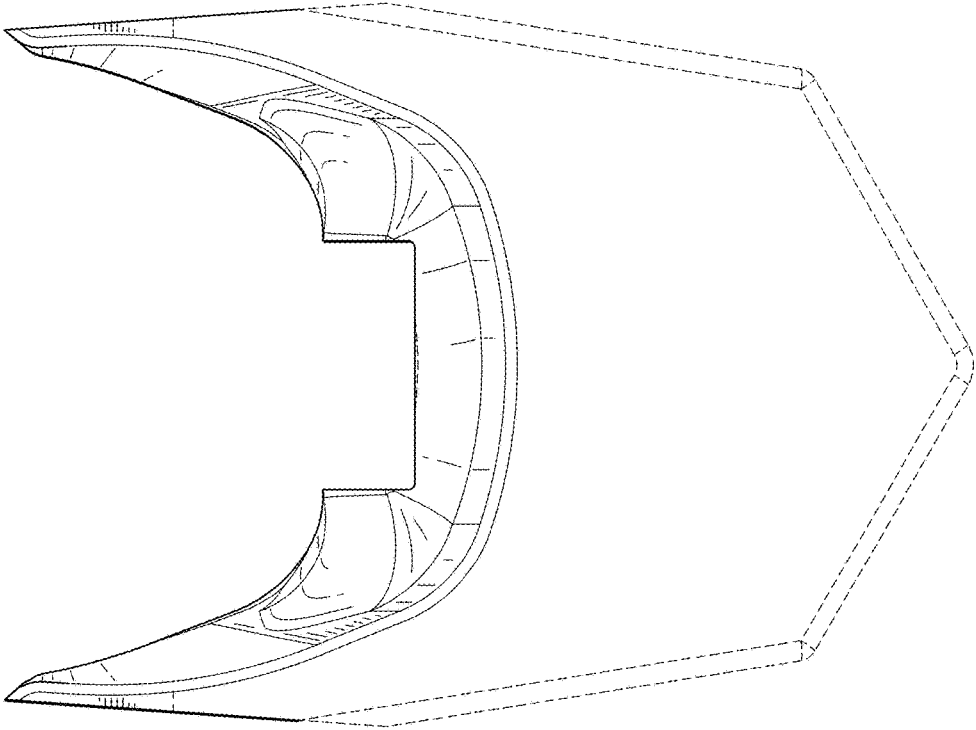

FIG. 12

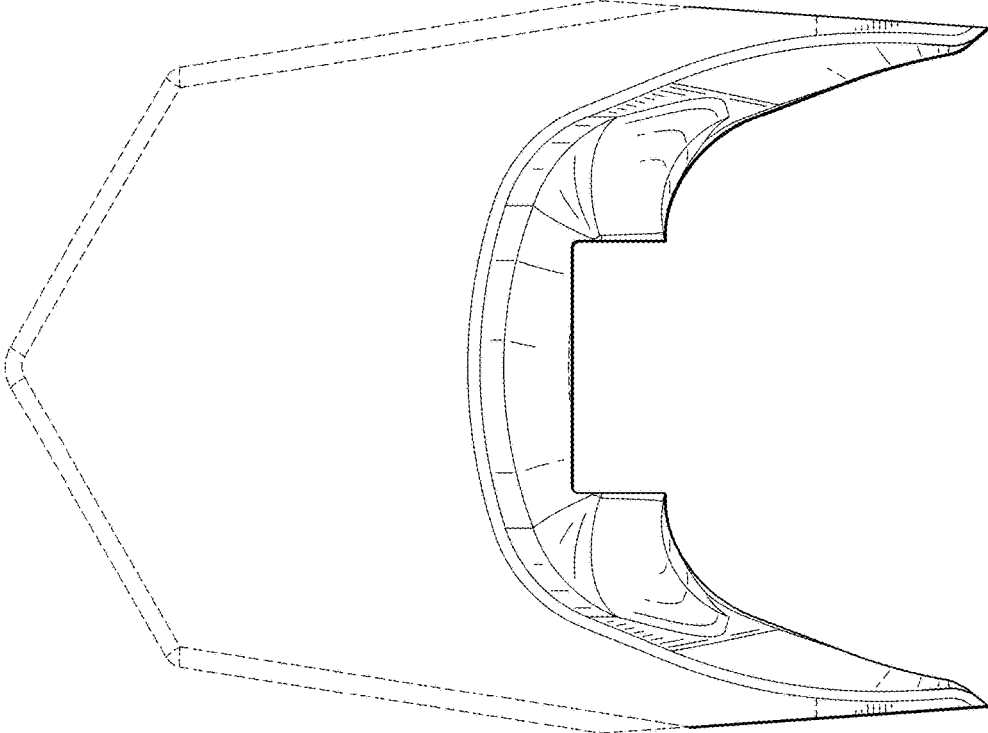

FIG. 13

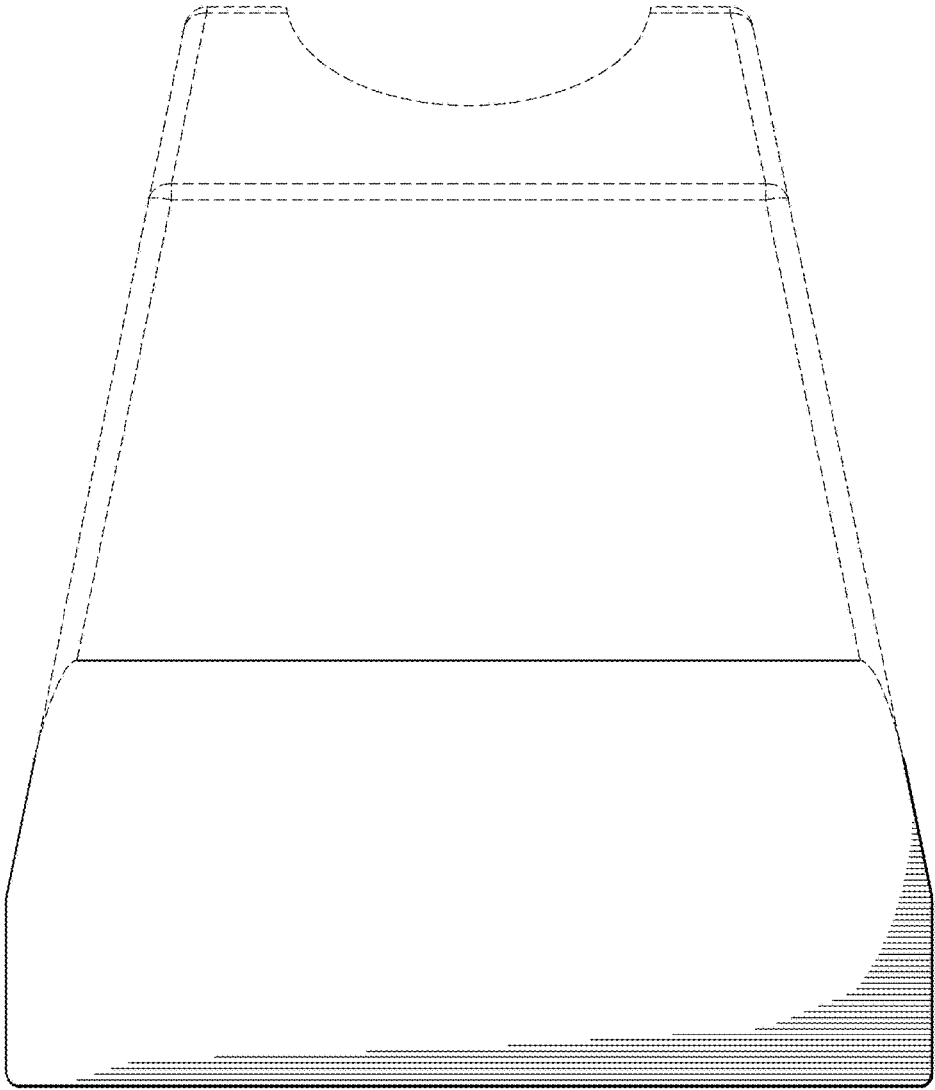

FIG. 14

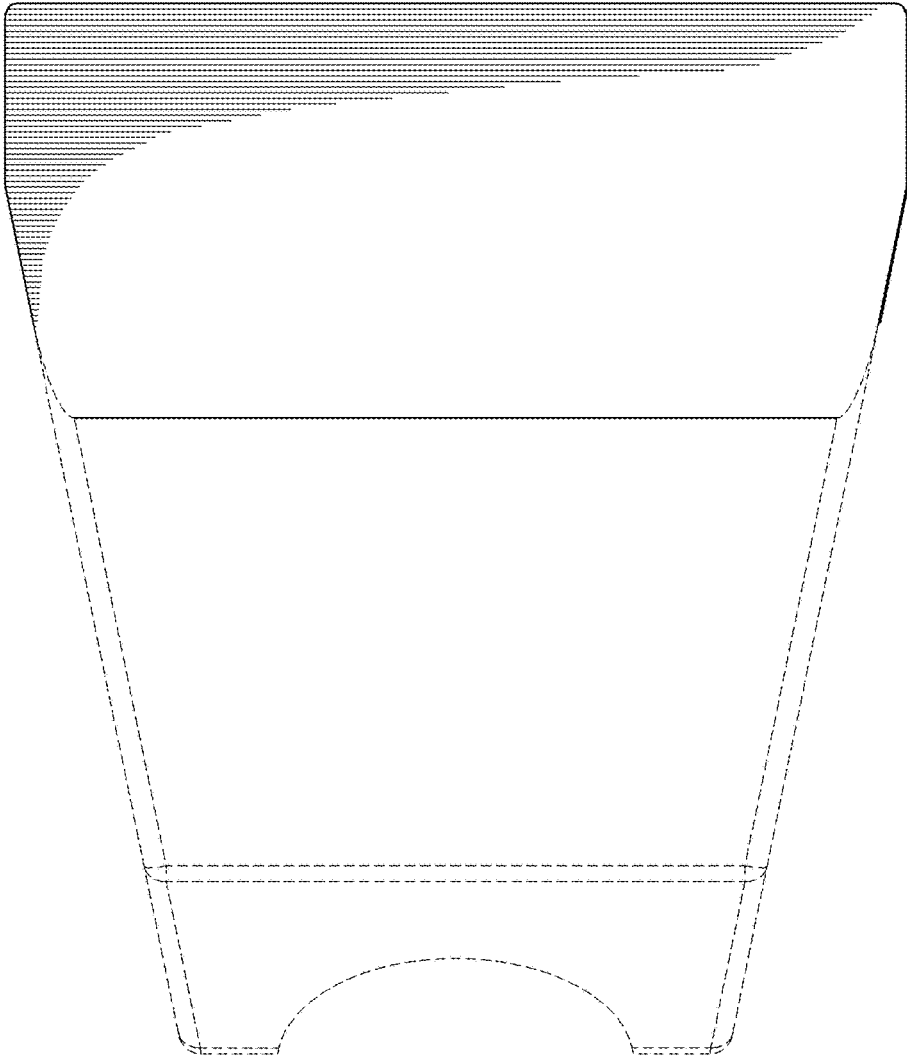

FIG. 15

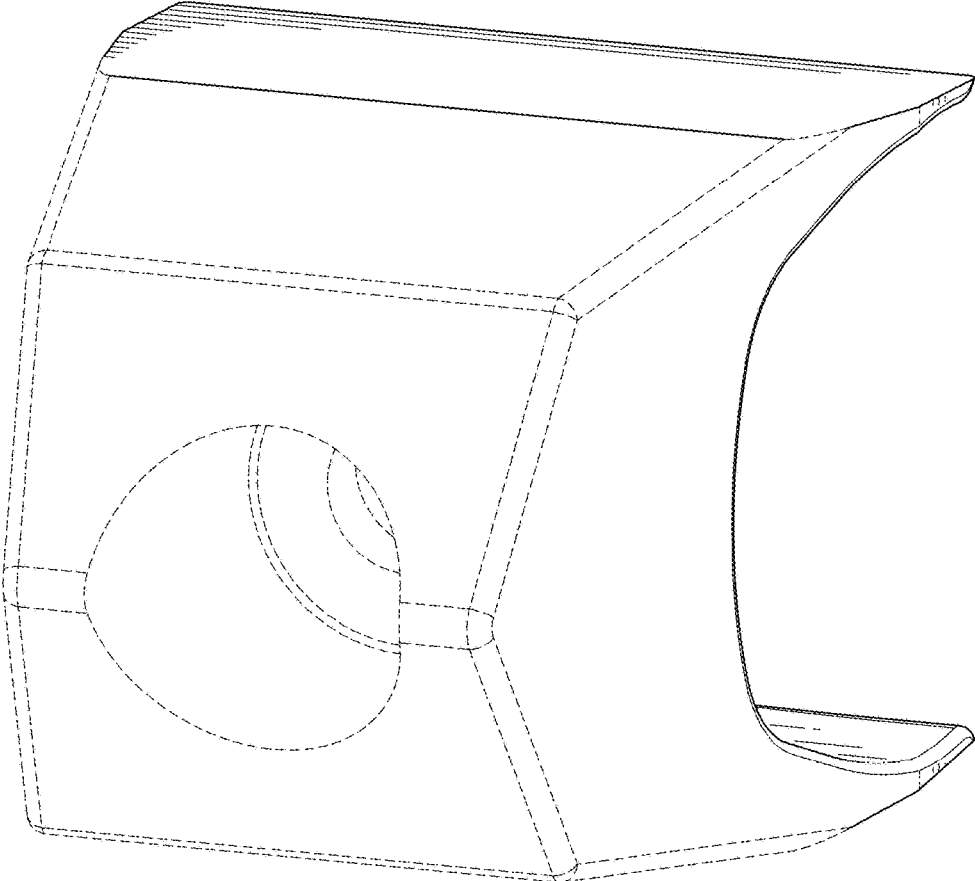

FIG. 16