

P. PHILLIPI.

Axle-Box.

No. 62,221.

Patented Feb. 19, 1867.

*Fig. 1.*

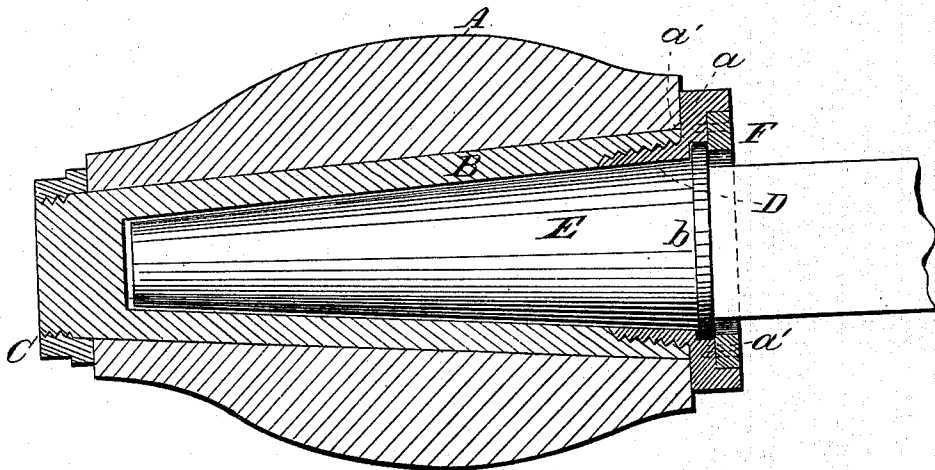

*Fig. 2.*

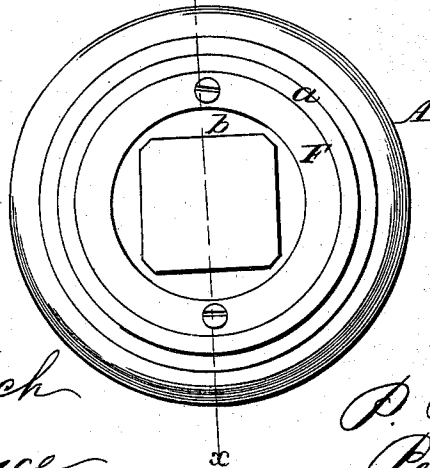

*Witnesses.*

*Theo Tusch*  
*J. A. Service*

*Inventor.*

*P. Phillipi*  
*Per Munn & Co*  
*Attorneys*

# United States Patent Office.

P. PHILIPPI, OF BEARDSTOWN, ILLINOIS.

Letters Patent No. 62,221, dated February 19, 1867.

## IMPROVEMENT IN AXLE-BOX.

The Schedule referred to in these Letters Patent and making part of the same.

### TO ALL WHOM IT MAY CONCERN:

Be it known that I, P. PHILIPPI, of Beardstown, Cass county, State of Illinois, have invented a new and improved Axle-Box for the wheels of vehicles; and I do hereby declare that the following is a full, clear, and exact description thereof, which will enable others skilled in the art to make and use the same, reference being had to the accompanying drawings, forming part of this specification, in which—

Figure 1 is a longitudinal central section of my invention.

Figure 2, a rear or inner view of the same.

Similar letters of reference indicate like parts.

This invention relates to a new and useful improvement in axles-boxes for the hubs of wheels for vehicles, whereby the wheel may be secured upon its axle and removed therefrom with the greatest facility, the lubricating material retained in the axle-box, and dust effectually excluded therefrom.

A represents a hub of a wheel; and B a box fitted thereon. This box may be of cast iron or other suitable metal, and it is closed at its front end and extends some distance beyond the front end of the hub, and has a screw-thread upon it to receive a nut, C. The rear end of the box B is flush with the rear end of the hub A, and within the rear end of the box a screw is cut to receive a screw on a thimble, D, the latter being provided with a flange, *a*, which fits simply against the rear end of the hub. The box B, nut C, and thimble D, all turn with the hub A, on the arm E of the axle, and the thimble D has a shoulder, *a'*, formed in it for a collar, *b*, on the arm E to bear against an annular flange F, being secured within a recess in the outer side of the thimble so as to lap over the collar *b*, as shown clearly in fig. 1. By this means it will be seen that the hub A is retained on the arm E, and at the same time allowed to turn freely upon it. The grease or lubricating material is also retained within the box B, and dust or dirt effectually excluded therefrom. The hub is detached from the arm by holding the thimble D with a wrench so as to prevent it from turning, and then turning the hub or wheel so as to unscrew the box from the thimble, the latter remaining on the arm.

Having thus described my invention, what I claim as new, and desire to secure by Letters Patent, is—

The box B, fitted in the hub A, and provided with a nut, C, on its outer end, in connection with the thimble D, provided with the screw, which is screwed into the inner end of the box, and the annular plate or flange F, secured in the outer side of the flange *a* of the thimble, with the collar *b* of the arm between the shoulder *a'* and the annular plate or flange, substantially as and for the purpose herein set forth.

P. PHILIPPI.

Witnesses:

EDW. PHILIPPI,

RUDOLPH I. PHILIPPI.