

(19)  
(12)

(KR)  
(B1)

(51) 。 Int. Cl. 7  
G02F 1/13

(45)  
(11)  
(24)

2001 10 27  
10 - 0299531  
2001 06 09

(21) 10 - 1998 - 0032376  
(22) 1998 08 10

(65) 2000 - 0013488  
(43) 2000 03 06

(73)

20

(72)

13 - 202 454 - 1

(74)

:

(54)

4

1

2 1

3

4 3

5 3 A - A'

6 3 B - B'

< >

2,12 : 4,14 :

8,18 : 10 :

11 : 16 :

20 :

(Liquid Crystal Display ; "LCD" ) , , 가 가 , LCD (NoTebook Personal Computer; "NTPC" ) 가 NTPC 가

; "LCM" ) 1 (Top Case;2) LCM(Liquid Crystal Module LCM LCM (2) LCM (Supporter Main;4) . LCM ,

(4) (Printed Circuit Board:8 "PCB" ) P CB(8) LCM ( ,TFT ) (Drive Integrated Circuit; "D - IC" )가 , TCP(Tape Carrier Package:6 "TCP" ) LCM D - IC( ) LCM D - IC LCM (8) D - IC

2 (4) (4) PCB(8)가  
 , PCB(8) (4) PCB(8) (4)  
 가 3mm (4) (4) (4)

(4) PCB(8) (10)  
 (10) , PCB(8) (10) (10)  
 (8) , PCB(8) (2) PCB(8) (4) PCB (4) PCB  
 (GND) , (4) PCB(8) PCB(8) (11)  
 가 , (4) PCB(8) PCB(8) TCP 가 (10)  
 , (11) PCB(8) 가 (4)

3 7

3 (14) PCB(18) LCM (14) (14) LCM (14)  
 PCB (16)가 , PCB (16) PCB(18)가 PCB(18)가 (14) PCB(18) (14)  
 PCB(18) (14) PCB (16) PCB (16) PCB (16) 가 (14)  
 (14) 가 PCB (16) (1)  
 6) PCB(18) 가

, 4 PCB (16) (14)

4 , PCB (16) (14) (16a) , (14)  
가 (16c) , PCB(18) (16b) , (16d)  
(GND) (20) . PCB (16) "U"  
(16b) 가 (16c) 2 (16d)가  
(16a) (16d) (14a) . 가  
(16c) "ㄱ" (14b) ,  
(16b) PCB (16) PCB(18) (16b) (16b)  
가 , PCB(18) (16b)  
(20) PCB(18) (GND) (12) (GND)  
, (20)  
(16a) 가 (16c) PCB (16) (14)  
(16b) PCB (16) PCB(18)

4 , (14) PCB (16) (14a) , PCB (16)  
(14b) . (14a) (14) PCB (16)  
(16a) , (14b) (14a)  
PCB (16) 가 (16c) (14b)

, (14), PCB (16) PCB(18)가 가 5 (14)  
LCM , (14) PCB (16)가 , PCB (16)  
(16a) (14) (14a) 가 , PCB (16)  
(16b) (22) PCB (16) PCB(18) 가  
, (14), PCB (16) PCB(18)가 가 6 (14)  
LCM , (14) PCB (16)가 , PCB (16)  
16) 가 (16c) (14) (14b)

, PCB PCB

가

(57)

1.

2.

1 ,

가 .

3.

1 ,

가 ,

가 ,

4.

3 ,

가 .

5.

4 ,

1

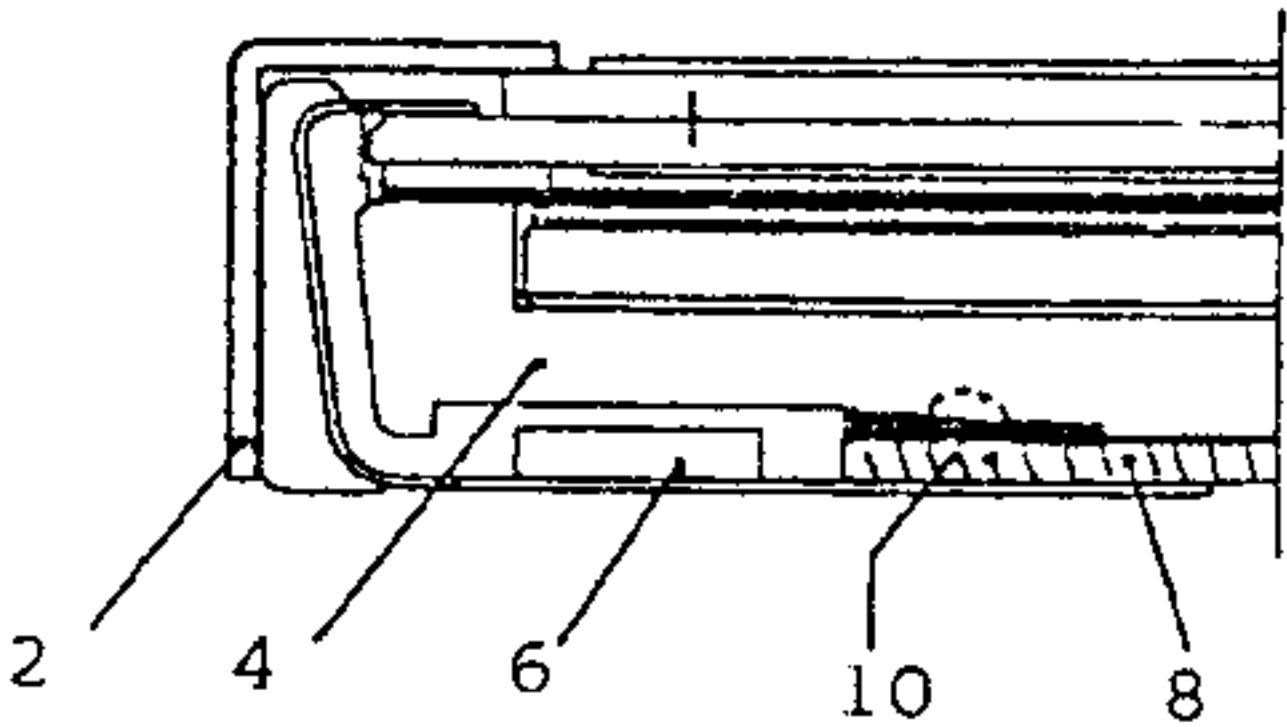

2

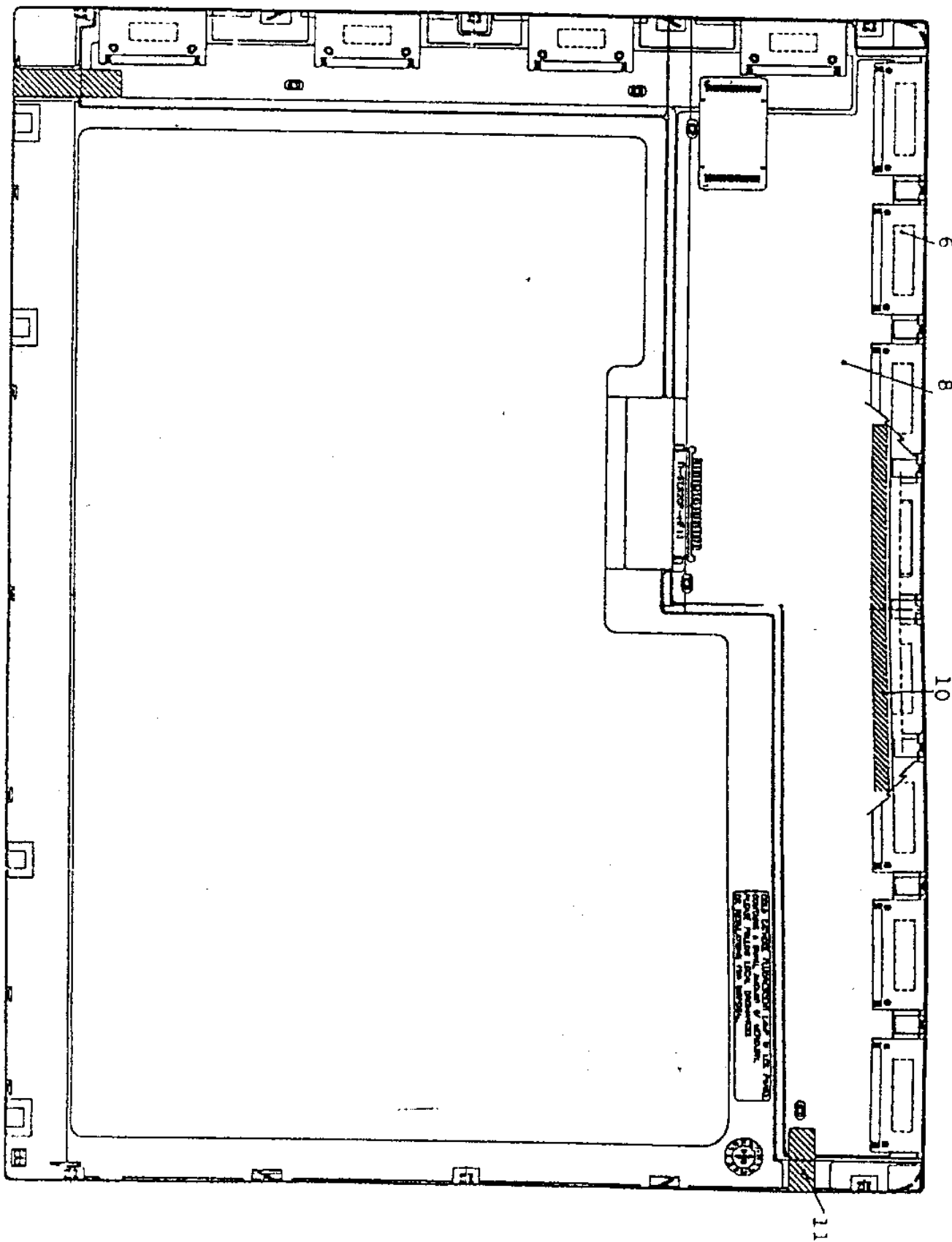

4

3

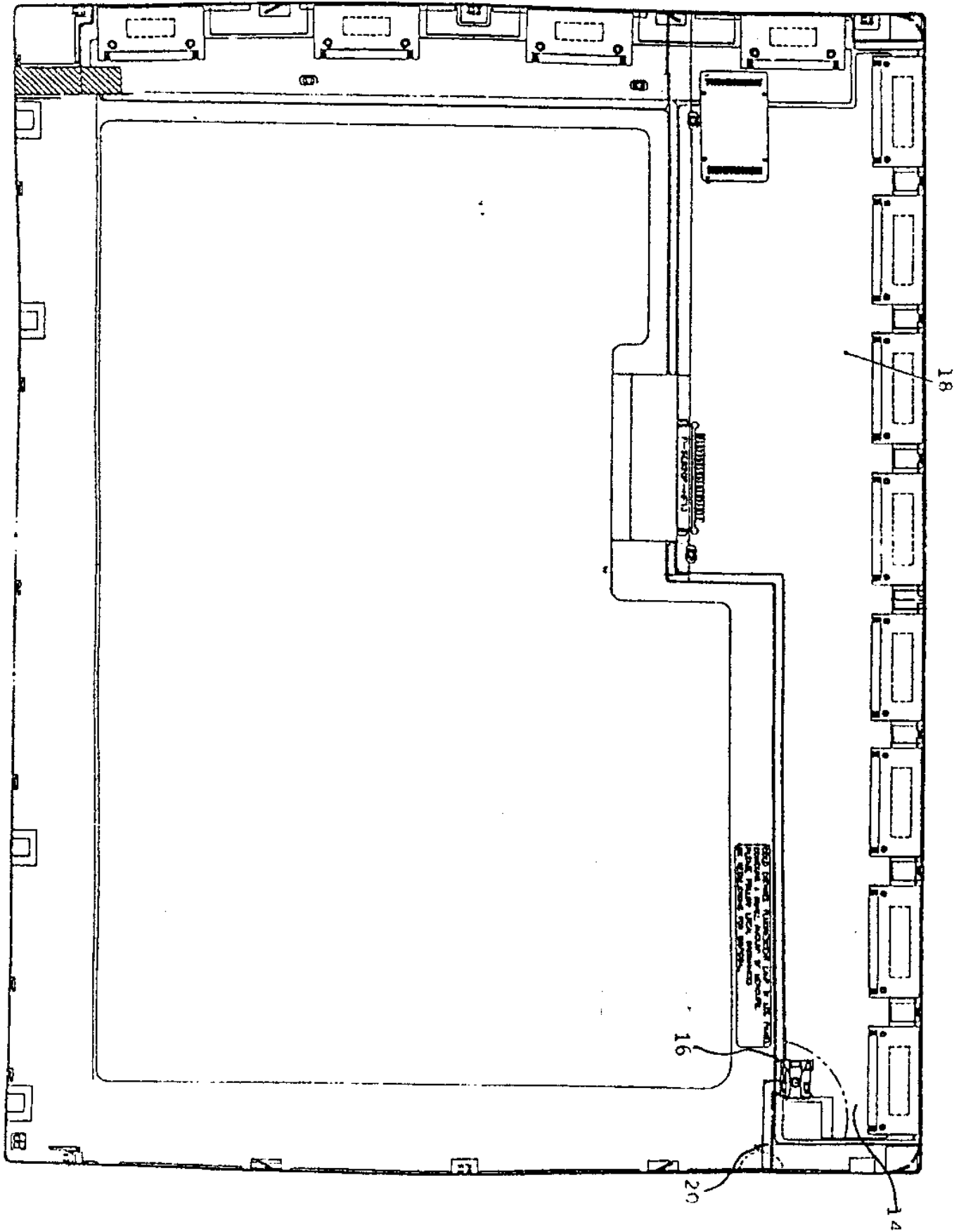



4

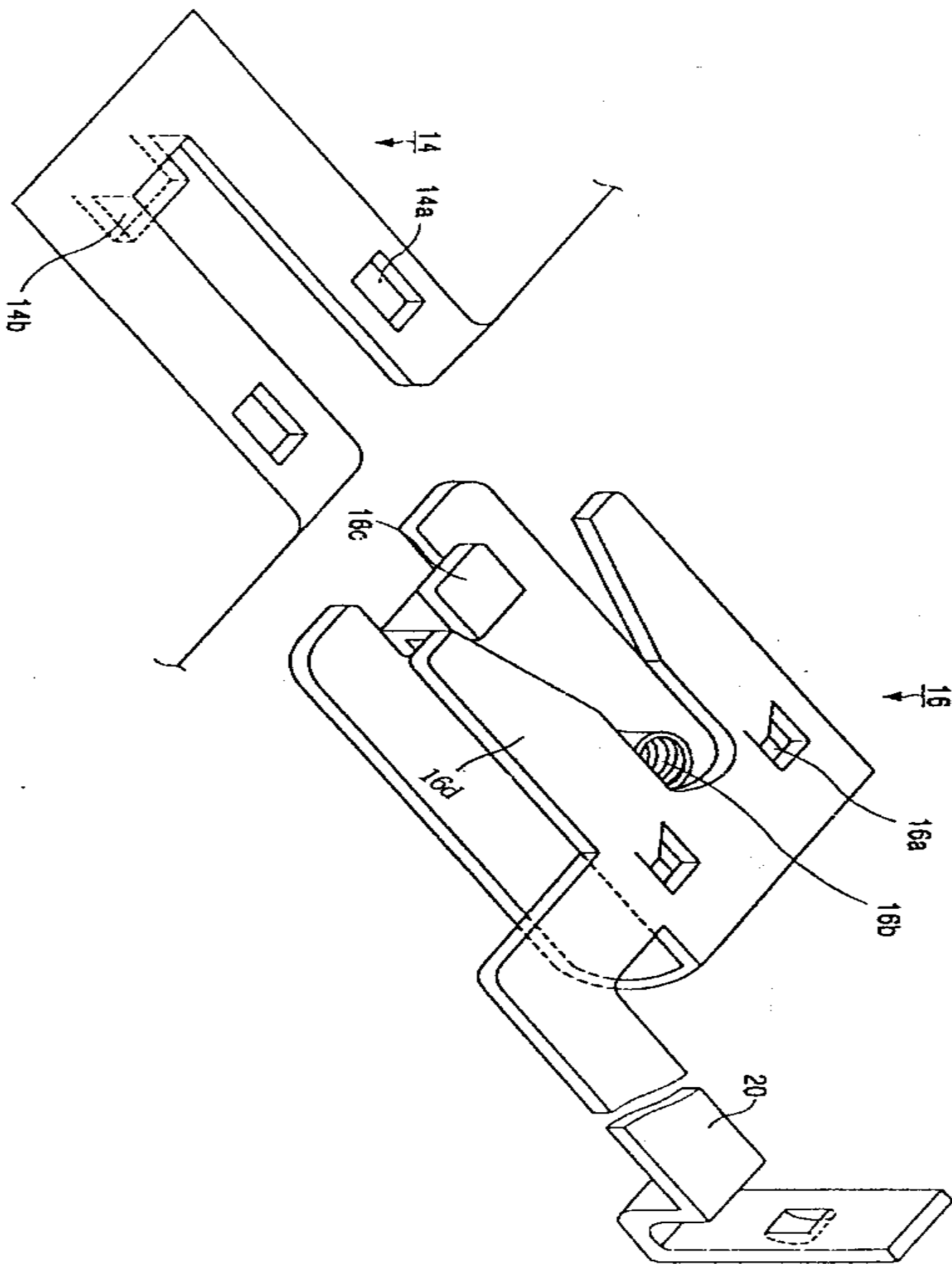

5

