



- (51) International Patent Classification:  
A61B 5/1455 (2006.01)
- (21) International Application Number:  
PCT/US2012/059986
- (22) International Filing Date:  
12 October 2012 (12.10.2012)
- (25) Filing Language: English
- (26) Publication Language: English
- (30) Priority Data:  
61/547,670 14 October 2011 (14.10.2011) US  
13/650,693 12 October 2012 (12.10.2012) US
- (71) Applicant: BEAM TECHNOLOGIES, LLC [US/US];  
P.o. Box 17541, Louisville, KY 40217 (US).
- (72) Inventors: DYKES, Daniel, E.; 1302 Texas Avenue,  
Louisville, KY 40217 (US). FROMMEYER, Alex, X.;  
1302 Texas Avenue, Louisville, KY 40217 (US). CURRY,  
Alexander, D.; 6706 Crossways Place, Louisville, KY  
40241 (US).
- (74) Agent: CURRY, Alexander, D.; Beam Technologies,  
LLC, P.O. Box 17541, Louisville, KY 40217 (US).

(81) Designated States (unless otherwise indicated, for every kind of national protection available): AE, AG, AL, AM, AO, AT, AU, AZ, BA, BB, BG, BH, BN, BR, BW, BY, BZ, CA, CH, CL, CN, CO, CR, CU, CZ, DE, DK, DM, DO, DZ, EC, EE, EG, ES, FI, GB, GD, GE, GH, GM, GT, HN, HR, HU, ID, IL, IN, IS, JP, KE, KG, KM, KN, KP, KR, KZ, LA, LC, LK, LR, LS, LT, LU, LY, MA, MD, ME, MG, MK, MN, MW, MX, MY, MZ, NA, NG, NI, NO, NZ, OM, PA, PE, PG, PH, PL, PT, QA, RO, RS, RU, RW, SC, SD, SE, SG, SK, SL, SM, ST, SV, SY, TH, TJ, TM, TN, TR, TT, TZ, UA, UG, US, UZ, VC, VN, ZA, ZM, ZW.

(84) Designated States (unless otherwise indicated, for every kind of regional protection available): ARIPO (BW, GH, GM, KE, LR, LS, MW, MZ, NA, RW, SD, SL, SZ, TZ, UG, ZM, ZW), Eurasian (AM, AZ, BY, KG, KZ, RU, TJ, TM), European (AL, AT, BE, BG, CH, CY, CZ, DE, DK, EE, ES, FI, FR, GB, GR, HR, HU, IE, IS, IT, LT, LU, LV, MC, MK, MT, NL, NO, PL, PT, RO, RS, SE, SI, SK, SM, TR), OAPI (BF, BJ, CF, CG, CI, CM, GA, GN, GQ, GW, ML, MR, NE, SN, TD, TG).

**Published:**

— with international search report (Art. 21(3))

(54) Title: ORAL HEALTH CARE IMPLEMENT AND SYSTEM WITH OXIMETRY SENSOR

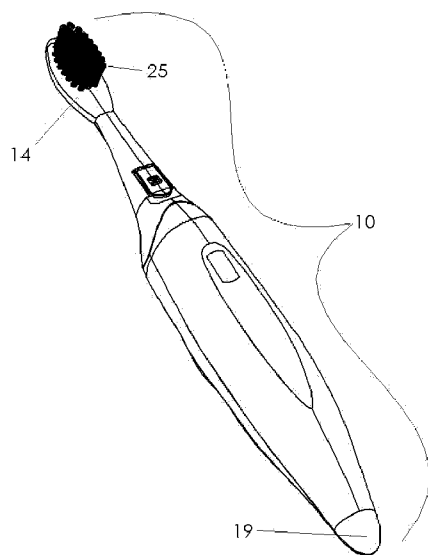

FIG. 1

(57) Abstract: An oral health care implement and system are provided for use during oral health care activities. The oral health care implement has an oximetry sensor, most often in the embodiment of a transmissive or reflective pulse oximeter. The oximetry sensor provides blood oxygen saturation and heart rate measurements. The oral health care system has an oral health care implement, a first data transfer medium, and any combination of: a second data transfer medium, a network storage device, and a third data transfer medium. The system provides means for collecting a user's vital signs and transmitting data into a readable, usable form for the user via an oral health care implement.



# ORAL HEALTH CARE IMPLEMENT AND SYSTEM WITH OXIMETRY SENSOR

## TECHNICAL FIELD

[0001] This invention relates to oral health care implements and systems, particularly relating to improved toothbrushes utilizing new technologies for the dental field. In particular, the invention relates to the vital sign monitoring capabilities of both manual and electric toothbrushes.

## BACKGROUND ART

[0002] Dental plaque is a biofilm that forms naturally on teeth between brushing and dental visits. Dental plaque can be a precursor to more severe oral health problems including: dental caries, tooth decay, gingivitis, and chronic periodontitis. The occurrence of dental caries is one of the largest health epidemics in the world and is the most common chronic childhood disease in the United States. Likewise, gingivitis and dental calculus are two of the most common systemic diseases of the body. It is desirable to monitor and diagnose dental plaque early stage as a preventive measure against more serious disease states. The most common preventive measure implemented to control the formation of dental plaque is the toothbrush.

[0003] Vital sign monitoring offers a long standing method of measuring the overall health of a patient. Vital signs most often include body temperature, heart rate, blood pressure, respiratory rate, and blood oxygen saturation. Effective monitoring of these bodily statistics allows for detection of overall health and diagnostic indicators of physiological disease states. The present invention offers solutions for the monitoring of two vital signs, which are blood oxygen saturation and heart rate. The present invention further offers the monitoring of these

vital signs in an implement that is presently common for everyday use to the majority of potential users.

**[0004]** The present invention aims to provide the monitoring of these vital signs in an oral health implement that is utilized in many peoples' everyday routines. A common oral health implement is a toothbrush. A toothbrush is recommended for use twice daily, thus making it ideal for daily monitoring of vital signs. Integration of a networked system for the transmission and access of vital sign data allows medical practitioners to monitor patients as a means for early prevention of certain physiological conditions.

**[0005]** An ideal method for monitoring blood oxygen saturation and heart rate is photoplethysmography, more commonly referred to as pulse oximetry. The principle of pulse oximetry is based on the red and infrared light absorption characteristics of oxygenated and deoxygenated hemoglobin, where oxygenated hemoglobin absorbs more infrared light and deoxygenated hemoglobin absorbs more red light. Light absorption occurs in various stages including constant light absorption due to tissue and bone, constant light absorption due to venous blood, constant light absorption due to non-pulsatile arterial blood, and variable light absorption due to pulsatile volume of arterial blood. The absorption stage of interest in most cases is the variable light absorption due to pulsatile volume of arterial blood. The heart rate is determined by the frequency of the peaks that indicate surges of blood volume due to heart beats. The variable light absorption is often further utilized to measure blood oxygen saturation.

**[0006]** Consequently, medical practitioners are in need of an adequate means to monitor the vital signs of patients as early stage detection of physiological conditions. Moreover, patients are in need of a convenient method of vital sign data collection that does not greatly affect their daily

routine. Consequently, a convenient method of measuring and monitoring vital signs such as blood oxygen saturation and heart rate is desirable for both medical practitioners and patients.

#### DISCLOSURE OF THE INVENTION

[0007] The invention aims to provide an oral health care implement and system with an oximetry sensor for the detection and monitoring of blood oxygen saturation, heart rate, and any combination thereof. The implement is most often a toothbrush **10** that has bristles **25** for cleaning. The toothbrush **10** has an oximetry sensor **151** that detects any combination of the user's blood oxygen saturation and heart rate. This allows the user to monitor his/her blood oxygen saturation and heart rate while performing the typically required task of brushing one's teeth.

[0008] The oximetry detection is transmitted to a first data transfer medium **201** where the data is received, stored, and processed. Optionally, the data is then further transmitted to a third data transfer medium **221**, where the data is received, transmitted, stored, and processed. Accordingly, the data may be displayed in a user-readable format **401** on either the first data transfer medium **201**, the second data transfer medium **211**, the third data transfer medium **221**, or any combination thereof.

[0009] Accordingly, several advantages are to provide an oral health care implement, to provide means for monitoring one's blood oxygen saturation and/or heart rate, and to provide transmission of oximetry data to a convenient display medium. Still further advantages will become apparent from a study of the following descriptions and the accompanying drawings.

## BRIEF DESCRIPTION OF DRAWINGS

[0010] Figure 1 is a perspective view of a toothbrush with bristles according to multiple embodiments and alternatives.

[0011] Figure 2 is a plan view of a toothbrush with bristles according to multiple embodiments and alternatives.

[0012] Figure 3A is a plan view of the back of a toothbrush with a diagnostic ultrasonic sensor according to multiple embodiments and alternatives.

[0013] Figure 3B is a detail view of the back of a toothbrush with a diagnostic ultrasonic sensor according to multiple embodiments and alternatives.

[0014] Figure 4A is a plan view of the front of a toothbrush with a diagnostic ultrasonic sensor according to multiple embodiments and alternatives.

[0015] Figure 4B is a detail view of the front of a toothbrush with a diagnostic ultrasonic sensor according to multiple embodiments and alternatives.

[0016] Figure 5 is a plan view of the back of a toothbrush with a proximity sensor according to multiple embodiments and alternatives.

[0017] Figure 6A is a plan view of the front of a toothbrush with a proximity sensor according to multiple embodiments and alternatives.

[0018] Figure 6B is a section view of a toothbrush with a proximity sensor according to multiple embodiments and alternatives.

[0019] Figure 6C is a detail view of a toothbrush with a proximity sensor according to multiple embodiments and alternatives.

[0020] Figure 7A is a plan view of the front of a toothbrush with a temperature sensor according to multiple embodiments and alternatives.

[0021] Figure 7B is a section view of a toothbrush with a temperature sensor according to multiple embodiments and alternatives.

[0022] Figure 8 is a plan view of the front of a toothbrush with an oximetry sensor according to multiple embodiments and alternatives.

[0023] Figure 9 is a perspective view of a toothbrush and a personal computer system according to multiple embodiments and alternatives.

[0024] Figure 10 is a perspective view of a toothbrush and a mobile communication device according to multiple embodiments and alternatives.

[0025] Figure 11 is a perspective view of a toothbrush and a tablet personal computer according to multiple embodiments and alternatives.

[0026] Figure 12 is a schematic view of a sensor surface of a proximity sensor according to multiple embodiments and alternatives.

[0027] Figure 13 is a flow diagram of potential data transfer paths according to multiple embodiments and alternatives.

[0028] Figure 14 is an example screen shot of a user-readable format according to multiple embodiments and alternatives.

[0029] Figure 15 is an example screen shot of a user interface according to multiple embodiments and alternatives.

#### MODES FOR CARRYING OUT THE INVENTION

[0030] The oral health care implement and system with oximetry sensor is encompassed in a plurality of preferred embodiments that shall be discussed in the present section.

[0031] A plurality of embodiments comprise an oral health care implement. In some embodiments, the oral health care implement is operated in the oral cavity of a human being characterized as the first portion of the alimentary canal that receives food and saliva, and containing a mucous membrane epithelium lining referred to as the oral mucosa. The oral cavity is further characterized as having alveolar arches typically containing teeth, which are either natural, synthetic, or a combination thereof, and used primarily for the preparatory chewing of food for digestion. The implement, in this embodiment, is capable of being operated within the oral cavity, wherein the implement is capable of being operated in a high moisture environment and is manufactured from bio-compatible materials approved for use in the oral cavity.

[0032] In some embodiments, the oral health care implement comprises a handle characterized by three general sections, which are a distal end **14**, a middle portion, and a proximal end **19**. The distal end **14** of the handle is regarded as the end of the handle that is the extreme end away from the user's primary point-of-contact with the handle, which, in some embodiments, is the extreme end away from the user's hand. The distal end **14**, in some embodiments, is further characterized as the end of the handle that is most prominently utilized in the implement's working area, which is the oral cavity in a plurality of embodiments. The proximal end **19** of the handle is characterized as the end of the handle that is closest to the user's primary point-of-contact, which, in some embodiments, is the user's point-of-contact with the handle. The middle portion of the handle is characterized as the portion of the handle centrally located between the distal end **14** and the proximal end **19** of the handle.

[0033] In some further embodiments, the oral health care implement is a toothbrush **10**. A toothbrush **10** is an oral health care implement used for the cleaning of teeth and gingiva, more commonly referred to as gums. A toothbrush **10** comprises a brush head consisting of a plurality

of bristles **25** arranged into compact clusters, often referred to as tufts, mounted onto the brush head. Accordingly, the tufts are often mounted in an intentional pattern to facilitate cleaning of teeth and gums. A toothbrush **10** further comprises a handle that includes the brush head and extends proximally from the brush head, which is used for grasping and movement of the toothbrush **10**. The handle, consequently, has a distal end **14** and a proximal end **19**. The distal end **14** of a toothbrush **10** handle, in some embodiments, is the brush head of the toothbrush **10** where said bristles **25** reside. The proximal end **19** of a toothbrush **10** handle, in some embodiments, is the extreme opposite end from the brush head where the user grasps the handle. In some embodiments, the bristles **25** are manufactured from either a natural material, synthetic material, or a combination thereof. One example of a natural material is animal hair. An example of a typical synthetic material used in toothbrush bristles is Nylon.

**[0034]** In some further embodiments, the oral health care implement is a flosser. A flosser is an oral health care implement used for the removal of food and dental plaque from teeth, especially between teeth and other places a toothbrush cannot effectively clean. A flosser comprises a flosser head having two parallel protrusions with space between them such that a length of dental floss can be placed between the two protrusions. The dental floss is, most often, held taut by the two protrusions to facilitate proper cleaning. A flosser further comprises a handle connected to the flosser head, which may be detachably connected. The handle has a distal end, middle portion, and proximal end such that the middle portion is contained between the distal end and proximal end. Two common orientations exist for the protrusions and the handle including F-shaped wherein the protrusions are generally perpendicular to the long axis of the handle; and the Y-shaped wherein the protrusions are generally parallel to the long axis of the handle. The handle and protrusions are most often manufactured from plastic. The dental floss



is typically manufactured from either thin nylon filaments or plastic ribbons. Further variations in dental floss include flavored or unflavored, and waxed or unwaxed.

**[0035]** In other further embodiments, the oral health care implement is a floss pick, which is an oral health care implement used for the removal of food and dental plaque from teeth. The floss pick shares many of the characteristics of the flosser with one major difference at the proximal end of the handle. The proximal end of the handle of the flosser is primarily used for grasping the implement. The proximal end of the floss pick is tapered into a point, much like the end of a toothpick, to further facilitate proper cleaning of teeth. Much like the flosser, the floss pick protrusions also are largely oriented in either an F-shape or Y-shape.

**[0036]** Further still, in some embodiments, the oral health care implement is a gum massager. A gum massager is an oral health care implement used for the stimulation of gums to promote better oral health. A gum massager comprises a massager head shaped to facilitate effective stimulation of gums. The massager head is often in the form of a rubber tip. A gum massager further comprises a handle with a distal end, middle portion, and proximal end. The handle is largely used for movement and manipulation of the implement for proper use.

**[0037]** In some further embodiments, the oral health care implement is a tongue cleaner, which is used for cleaning bacteria, food debris, fungi, and dead cells from the surface of the tongue. A tongue cleaner comprises a cleaning head on the distal end of a handle having a distal end, middle portion, and proximal end. The cleaning head often comprises a plurality of small ridges oriented perpendicular to the long axis of the handle. The ridges are moved along the surface of the tongue to scrap off unwanted matter.

**[0038]** In some embodiments, the oral health care implement is an interdental brush used for cleaning between teeth. An interdental brush comprises a brush head that comprises the small

brush sized to fit between a user's teeth. The brush head is located at the distal end of a handle, wherein the handle has a distal end, middle portion, and proximal end. An interdental brush is also commonly referred to as an interproximal brush or a proxy brush.

[0039] Alternatively, the oral health care implement is a prophy cup used in dental prophylaxis. A prophy cup is attached to the distal of end of the handle and is often rubber. The prophy cup holds a certain amount of abrasive polishing compound and typically is moved in a rotary motion to facilitate cleaning.

[0040] Inherently, an implement has an associated motion when in use which is characterized as either manually driven or electromechanically driven. A manually driven motion is regarded as a motion generated by the user by his/her own power. Conversely, an electromechanically driven motion is characterized as a motion generated by electrical power which is converted to mechanical power used to create the specified electromechanically driven motion. In some embodiments, the electromechanically driven motion is a side-to-side oscillating motion also referred to as a vibratory motion. Often, the vibratory motion is generated by an electric motor with an eccentric weight on the drive shaft of the electric motor. In other instances, the vibratory motion is generated by an electrically conductive coil around the outside of a magnetic mass such that when an alternating current is applied to the coil the magnetic mass oscillates causing vibration of the implement. In some other embodiments, the electromechanically driven motion is a rotation-oscillation motion wherein the brush head rotates either clockwise or counter-clockwise and then rotates in the opposite direction of the first rotation. Electrical power is typically supplied by a battery.

[0041] In some embodiments, the oral health care implement further comprises an oximetry sensor **151**. In some embodiments, the oximetry sensor **151** is a transmissive pulse oximeter.

Optionally, the oximetry sensor **151** is a reflective pulse oximeter. Both types of oximetry sensors detect blood oxygen saturation and/or heart rate.

**[0042]** In some embodiments, the transmissive pulse oximeter comprises two distinct sides that are parallel with a space separating the two sides creating a measuring site such that a portion of the human body may be inserted between the two sides. The portion of the human body most often inserted in the measuring site is chosen from the group index finger, middle finger, ring finger, pinky finger, thumb, toe, ear lobe, and nose. Two light-emitting diodes (LED) are at least partially contained on the first parallel side creating an emitter. In some embodiments, the two LEDs produce beams of light at different frequencies, which include the range of about 600-750 nanometers (nm) and the range of about 850-1000 nm such that the frequencies produce red and infrared light, respectively.

**[0043]** Additionally, in some embodiments of the transmissive pulse oximeter, the second parallel side comprises a photo detector positioned to be opposite of the emitter such that the photo detector receives the emitted light that passes through the measuring site. The photo detector determines the amount of red and infrared light received, thus determining the amount of red and infrared light absorbed. Accordingly, the amounts of red and infrared light are transmitted by the transmitter of the transmissive pulse oximeter to the data processing unit **31** of the implement.

**[0044]** Optionally, the data processing unit **31** of the implement calculates the ratio of red light to infrared light after the emitted light passes through the measuring site and is received by the photo detector. The calculated ratio is compared to a data bank that relates the calculated ratio to blood oxygen saturation values. The heart rate is further determined by the amount of light absorption of the volume of arterial blood. As the heart pumps blood, the volume of arterial

blood increases thus creating a pulsatile change in light absorption. The heart rate is determined by the frequency of pulsatile changes representing heart beats.

[0045] Optionally, in some embodiments, the reflective pulse oximeter comprises one distinct side, referred to as the contact surface, that comprises both the light emitter and the photo detector such that the emitted light travels into the measuring site and is reflected back to the photo detector. The reflective pulse oximeter allows the user to contact only one surface on the implement. Accordingly, the reflective pulse oximeter may be contacted by the user during the normal operation of the implement such as brushing a user's teeth.

[0046] Accordingly, in some embodiments, the reflective pulse oximeter transmits the amounts of red and infrared light received by the photo detector via the transmitter to the data processing unit 31. Similarly, the ratio of red light to infrared light is calculated and compared to a data bank to correlate the ratio to a blood oxygen saturation value. Additionally, the heart rate of the user is determined in the same manner as described for the transmissive pulse oximeter.

[0047] In some embodiments, at least a portion of the oximetry sensor 151 is located on the proximal end 19 of the handle such that the user contacts the oximetry sensor during normal operation of the implement. Optionally, at least a portion of the oximetry sensor 151 is located on the middle portion of the handle such that the user contacts the oximetry sensor during normal operation of the implement.

[0048] In some embodiments of the transmissive pulse oximeter, the first and second parallel sides are located on the exterior of the handle such that a user may contact the transmissive pulse oximeter when the implement is fully assembled. In some embodiments, the two parallel sides are parallel to the exterior surface of the handle. Optionally, the two parallel sides are perpendicular to the exterior surface of the handle.

[0049] In some embodiments of the reflective pulse oximeter, the contact surface is positioned to be flush with the portions of the handle surrounding the reflective pulse oximeter such that the handle and the reflective pulse oximeter are comprised in a smooth surface. Optionally, the contact surface is positioned to be raised above the portions of the handle surrounding the reflective pulse oximeter such that the reflective pulse oximeter is noticeably distinct from the portions of the handle surrounding it. Optionally still, the contact surface is positioned to be flush with the portions of the handle surrounding the reflective pulse oximeter, and at least a portion of the handle not directly surrounding the reflective pulse oximeter is raised such that the reflective pulse oximeter is located in at least a partial depression indicating where the user shall place his/her thumb for contact with the contact surface.

[0050] In some embodiments, the oximetry sensor **151** may be a plurality of transmissive pulse oximeters. Optionally, in some embodiments, the oximetry sensor **151** may be a plurality of reflective pulse oximeters. Also, in some embodiments, the oximetry sensor **151** may be a combination of at least one transmissive pulse oximeter and at least one reflective pulse oximeter.

[0051] In some embodiments, the oximetry sensor **151** transmits at least one signal indicative of oximetry. Optionally, the oximetry sensor **151** transmits signals utilizing an electrically conductive wire, wherein the electrical output of the oximetry sensor **151** is input to the electrically conductive wire and transmitted thereon. The electrical output of the oximetry sensor **151** is, otherwise, referred to as the signal indicative of oximetry. The electrically conductive wire allows for the transmission of the signal indicative of oximetry.

[0052] In some embodiments, the oral health care implement comprises a proximity sensor **90**. In some embodiments, the proximity sensor **90** is a capacitive sensor. One type of

capacitive sensor is a capacitive sensor that works with a frequency change, alternatively referred to as a frequency change capacitive sensor. Optionally, another type of capacitive sensor is a capacitive sensor that works with a capacitive voltage divider, alternatively referred to as a voltage divider capacitive sensor. Both types of capacitive sensors detect the added capacitance of the oral cavity.

[0053] In some embodiments, the frequency change capacitive sensor comprises a sensor surface **103**, a resistor-capacitor (RC) circuit, and an RC oscillator, wherein the capacitance of the oral cavity introduced by the sensor surface **103** is a parallel capacitance in the RC circuit such that, when the capacitance of the oral cavity is present, the overall capacitance of the RC circuit is altered. The RC oscillator operates at a set frequency controlled by the capacitance of the RC circuit. The sensor surface **103** comes into proximity of the oral cavity, and, consequently, the capacitance of the oral cavity is introduced to the RC circuit by a connection between the sensor surface **103** and the RC circuit such that the capacitance of the oral cavity is a parallel capacitance to the RC circuit. The change in overall capacitance of the RC circuit changes the frequency of the RC oscillator, thus, indicating the oral cavity is in proximity to the sensor surface **103**.

[0054] In some embodiments, the frequency of the RC oscillator is compared to a reference value to determine if a change in frequency occurs; therefore, the presence of the oral cavity is detected. Accordingly, three alternatives are presented for performing the comparison between the reference value and the frequency of the RC oscillator. One alternative is to define the reference value as a frequency equivalent to the operating frequency of the RC oscillator when the oral cavity is not in proximity to the sensor surface **103**. In this instance, the reference value and the frequency of the RC oscillator are both input into a frequency comparator, wherein the

frequency comparator evaluates if the values are similar; and thus, indicating one way or the other.

[0055] Optionally, the second alternative for comparison of the reference value and the frequency of the RC oscillator comprises a frequency-to-voltage converter, a DC voltage reference value, and a comparator, wherein the frequency of the RC oscillator is input to the frequency-to-voltage converter and a voltage corresponding to the frequency is output. The comparator compares the output voltage of the frequency-to-voltage converter to the DC voltage reference value. The DC voltage reference value is equivalent to the output voltage of the frequency-to-voltage converter when the oral cavity is not in proximity to the sensor surface **103**. Accordingly, the comparator outputs a signal consistent with whether the DC voltage reference value is similar to the output of the frequency-to-voltage converter.

[0056] Optionally, the third alternative for comparison of the reference value and the frequency of the RC oscillator is to directly measure the frequency of the signal by counting the number of rising or falling edges in a defined time period utilizing a device similar to a microcontroller. In this manner, a baseline operating frequency may be established, and any deviation in frequency beyond a defined threshold will indicate the oral cavity is in proximity to the sensor surface **103**.

[0057] In some embodiments, the voltage divider capacitive sensor comprises a sensor surface **103**, which provides an analog input; a reference voltage; an analog-to-digital converter (A/DC); and a A/DC capacitor. The A/DC is internally driven to the reference voltage such that the A/DC capacitor is fully charged, and the analog input of the sensor surface **103** is internally grounded such that the sensor surface **103** is fully discharged. Next, the analog input of the sensor surface **103** is internally disconnected from the ground and is internally connected to the

A/DC such that the A/DC capacitor will discharge at least a portion of its charge to the sensor surface **103** in order to equal the voltages of the sensor surface **103** and the A/DC capacitor. If the oral cavity is in proximity to the sensor surface **103**, the sensor will appear to have a larger capacitance. Said larger capacitance results in a many time smaller steady-state voltage between the A/DC capacitor and the sensor as compared to the condition when the sensor is in its normal, low capacitance state. The A/DC may measure the analog input and compare it to a threshold to determine if the sensor surface **103** is in proximity to the oral cavity. The voltage provided to the A/DC will decrease in a manner indicative of the oral cavity's proximity to the sensor surface **103**. In some embodiments, the decrease in a manner indicative of the oral cavity's proximity to the sensor surface **103** is significant.

[0058] In some embodiments, the reference voltage, the A/DC, and the A/DC capacitor are comprised in a microcontroller such that circuit comprises a sensor surface **103** with an analog input connected to the microcontroller. The A/DC of the microcontroller converts the voltage provided to the A/DC from an analog signal to a digital signal. The microcontroller determines whether the sensor surface **103** is in proximity to the oral cavity based on the digital signal.

[0059] In some embodiments, the sensor surface **103** is a conductive material and covered with an insulator material **97** such that the sensor surface **103** can be embedded into the distal end **14** of the handle of the implement. Alternatively, in embodiments where the implement is a toothbrush **10**, the sensor surface **103** may be embedded in the brush head or the neck of the toothbrush **10**. The sensor surface **103** embedded in the brush head or the neck of the toothbrush **10** would allow for proximity detection of the oral cavity when the toothbrush **10** was used for brushing a user's teeth, thus, providing information for when a toothbrush **10** is in use; or, alternatively, not in use.



[0060] In some embodiments, the insulator material **97** covering the sensor surface **103** is the same material as the body of the implement. In some embodiments where the implement is a toothbrush **10**, the insulator material **97** covering the sensor surface **103** is the same material as the body of the toothbrush **10** or the outer surface of the brush head.

[0061] An issue resides with the presence of water similarly producing a capacitance that may affect the sensor surface **103**. A desirable advancement of the present invention is to negate the issue of water unwantedly providing a capacitance indicative of the oral cavity's proximity to the sensor surface **103**. In some embodiments, the negation of water is provided by an effective thickness of insulator material **97** separating the water from the sensor surface **103**. The insulator material **97** allows detection of the sensor surface **103** in proximity to the oral cavity but does not allow detection of the sensor surface **103** in proximity to water. Alternatively, in some embodiments where the implement is a toothbrush **10**, the sensor surface **103** is functionally coupled to the bristles **25** of the brush head such that the bristles act as an insulator material. In the same manner, the bristles **25** allow detection of the sensor surface **103** in proximity to the oral cavity but do not allow detection of the sensor surface **103** in proximity to water.

[0062] In some embodiments, the capacitance sensor may be constructed from two parallel conductive plates separated by an insulator such that, in the active portion of the sensor, the insulator allows for an air gap between the parallel plates. For example, the insulator comprises a hole that allows for an air gap between the parallel plates. Forces acting perpendicular to the plane of the parallel plates in the active region deform one conductor or both conductors. Accordingly, the parallel plates move closer together due to deformation, thus, increasing the capacitance of the sensor. In some embodiments where the implement is a toothbrush **10**, the

bristles **25** comprised in the brush head are operatively attached to at least one of the parallel plates, wherein the act of brushing may be detected by the force exerted by the bristles **25** on the brush head. Thus, the act of brushing indicates the sensor is in proximity to the oral cavity.

**[0063]** In some embodiments, the proximity sensor **90** is a contact microphone, wherein the contact microphone detects vibration. The contact microphone detects vibration created by the use of the implement in the oral cavity. In some embodiments, the contact microphone is in contact with at least a portion of the body of the implement, such that the created vibrations are attenuated by the body of the implement. The vibrations detected by the contact microphone are compared to a reference that correlates to the detection of the implement in the proximity of the oral cavity. If the detected vibrations match the reference value, then the implement is in proximity to the oral cavity.

**[0064]** In some embodiments, the contact microphone is substantially contained in a portion of the implement chosen from the distal end **14**, the middle portion, the proximal end **19**, and any combination thereof. In some embodiments, the contact microphone is chosen from the group condenser microphone, electret condenser microphone, dynamic microphone, ribbon microphone, carbon microphone, piezoelectric microphone, fiber optic microphone, laser microphone, liquid microphone, microelectromechanical system (MEMS) microphone, and any combination thereof.

**[0065]** Accordingly, a condenser microphone has a diaphragm that acts as one plate of a capacitor and vibrations alter the distance between the plates of the capacitor. Two-types of condenser microphones exist varying in the method of extracting the audio signal. The first type is DC-biased, wherein the plates are biased with a fixed charge and the voltage across the capacitor varies with variance in the capacitance due to vibrations. The second type is radio

frequency (RF), wherein a low RF voltage is generated by a low-noise oscillator and the signal from the oscillator is amplitude modulated by the capacitance changes caused by the sound waves moving the capsule diaphragm.

**[0066]** Similarly, an electret condenser microphone is consistent with a condenser microphone with one main difference being that the applied charge is provided by the permanent charge of an electret material. An electret material is a ferroelectric material that is permanently electrically charged or polarized.

**[0067]** Alternatively, a dynamic microphone has a small, movable induction coil that is located in the magnetic field of a permanent magnet, wherein the induction coil is attached to the diaphragm. As the diaphragm vibrates, the induction coil moves about the magnetic field causing a varying current in the coil through electromagnetic induction.

**[0068]** Similarly, a ribbon microphone operates based on magnetic induction. A thin, often corrugated, metal ribbon is suspended in a magnetic field such that the metal ribbon is operably connected to the microphone's output. The vibration of the metal ribbon within the magnetic field generates the electrical signal.

**[0069]** A carbon microphone utilizes a capsule containing carbon granules pressed between two metal plates, one of which is the diaphragm that vibrates in conjunction with sound waves. A voltage is applied across the metal plates that causes current to flow through the carbon granules. As the diaphragm vibrates, varying pressure is applied to the carbon granules, which causes them to deform and vary the contact area between each carbon granule. This variation changes the electrical resistance of the carbon granules, thus changing the current flowing through the microphone and causing the electrical signal.

[0070] Alternatively, a piezoelectric microphone utilizes the property of piezoelectricity exhibited by some materials. The vibrations are received by the piezoelectric material which translates the varying vibrations into varying electrical signals. Piezoelectric microphones are the most common type of contact microphone.

[0071] A fiber optic microphone operates by passing a laser source through the fiber optic that illuminates a reflective diaphragm. The diaphragm receives sound vibrations, which varies the intensity of the reflected light. The modulated light then passes through a second fiber optic on to a photo detector, which transforms the light into an electrical signal.

[0072] A laser microphone utilizes a laser beam aimed at a surface that attenuates vibration. The vibrations of the surface change the reflection angle of the laser beam, which is detected and converted into an electrical signal.

[0073] Alternatively, a liquid microphone comprises a metal cup filled with liquid and a diaphragm with a connected needle, such that vibrations cause the diaphragm to move up and down. Consequently, the needle oscillates in the water changing the electrical resistance between the needle and the metal cup.

[0074] Lastly, a MEMS microphone utilizes a pressure-sensitive diaphragm etched directly onto a silicon chip. The diaphragm is created by MEMS manufacturing techniques. Most often, MEMS microphones operate in a similar fashion to a condenser microphone.

[0075] In some embodiments, the oximetry sensor **151** transmits at least one signal indicative of oximetry. Optionally, the oximetry sensor **151** transmits signals utilizing an electrically conductive wire, wherein the electrical output of the oximetry sensor **151** is input to the electrically conductive wire and transmitted thereon. The electrical output of the oximetry

sensor **151** is, otherwise, referred to as the signal indicative of oximetry. The electrically conductive wire allows for the transmission of the signal indicative of oximetry.

**[0076]** In some embodiments, the oral health care implement further comprises a data processing unit **31** having at least one collector, a storage medium, and at least one processor, wherein the collector, storage medium, and processor, respectively, collect, store, and process data indicative of oximetry. Accordingly, in some embodiments, the data processing unit is chosen from the group microprocessor, microcontroller, field programmable gate array (FPGA), digital signal processing unit (DSP), application specific integrated circuit (ASIC), programmable logic, and combinations thereof.

**[0077]** Additionally, in some embodiments, the collector of the data processing unit **31** is an electrically conductive wire, wherein the electrically conductive wire receives the electrical output of the oximetry sensor **151**, such that the electrical output of the oximetry sensor **151** is at least one signal indicative of oximetry.

**[0078]** Moreover, in some embodiments, the storage medium of the data processing unit **31** is comprised of volatile memory and non-volatile memory, wherein volatile memory is used for short-term storage and processing, and non-volatile memory is used for long-term storage. Accordingly, in some embodiments, volatile memory is chosen from the group random-access memory (RAM), dynamic random-access memory (DRAM), double data rate synchronous dynamic random-access memory (DDR SDRAM), static random-access memory (SRAM), thyristor random-access memory (T-RAM), zero-capacitor random-access memory (Z-RAM), and twin transistor random-access memory (TTRAM). Optionally, in some embodiments, non-volatile memory is chosen from the group read-only memory (ROM), programmable read-only memory (PROM), erasable programmable read-only memory (EPROM), electrically erasable

programmable read-only memory (EEPROM), flash memory, ferroelectric random-access memory (FeRAM), magnetoresistive random-access memory (MRAM), phase-change memory (PRAM), conductive-bridging random-access memory (CBRAM), silicon-oxide-nitride-oxide-silicon memory (SONOS), resistive random-access memory (RRAM), racetrack memory, nano-random-access memory (NRAM), and Millipede memory.

[0079] Further still, in some embodiments, the processor of the data processing unit **31** is chosen from the group microprocessor and microcontroller.

[0080] Optionally, in some embodiments, the oral health care implement further comprises at least one data extractor of data indicative of oximetry in the form of a signal, such that the data can be extracted to be used by another medium. The signal can be extracted from the oral health care implement via the data extractor, optionally, after being received by the collector, the storage medium, or the processor, all of the data processing unit. Optionally, the data extractor is chosen from the group universal serial bus (USB), serial port, wired Ethernet port, radio frequency, microwave communication, infrared short-range communication, near field communication, and Bluetooth®.

[0081] In some embodiments, the oral health care implement comprises a power source **36** that distributes electrical energy to the electrically powered components of the oral health care implement including: the oximetry sensor **151**, the data processing unit **31**, and other components defined as requiring electrical power. Optionally, in some embodiments, the power source **36** is a battery that is comprised of one or more electrochemical cells that convert stored chemical energy into electrical energy, which is then distributed to the remaining electrically powered components. Two primary types of batteries are utilized in some embodiments

including disposable batteries and rechargeable batteries. Both types of batteries come in various sizes and types.

[0082] Optionally, the power source of the oral health care implement is a cable that temporarily connects the implement to electrical energy, thus delivering electrical energy to the electrically powered components of the implement. In some embodiments, the electrical energy transferred through the cable is chosen from the group alternating current (AC) and direct current (DC).

[0083] In some embodiments, the oximetry sensor **151** and the data processing unit **31** operate in conjunction to determine blood oxygen saturation and heart rate of the user. Thus, the combination of the oximetry sensor **151** and the data processing unit **31** provide an oximeter integrated with the implement.

[0084] In some embodiments, the oral health care implement further comprises at least one pressure sensor to determine if the pressure exerted on the implement is excessive in relation to its intended use. In some embodiments, the pressure sensor may be constructed from two parallel conductive plates separated by an insulator such that, in the active portion of the sensor, the insulator allows for an air gap between the parallel plates, referred to as a parallel plate capacitive sensor. For example, the insulator comprises a hole that allows for an air gap between the parallel plates. Forces acting perpendicular to the plane of the parallel plates in the active region deform one conductor or both conductors. Accordingly, the parallel plates move closer together due to deformation, thus, increasing the capacitance of the sensor.

[0085] One type of pressure sensor is a parallel plate capacitive sensor that works with a frequency change, alternatively referred to as a frequency change parallel plate capacitive sensor. Optionally, another type of pressure sensor is a parallel plate capacitive sensor that works with a

capacitive voltage divider, alternatively referred to as a voltage divider parallel plate capacitive sensor. Both types of pressure sensors detect the added capacitance of the applied pressure of the oral cavity.

**[0086]** In some embodiments, the frequency change parallel plate capacitive sensor comprises at least two conductive sensor surfaces, an intermediary insulator, a resistor-capacitor (RC) circuit, and an RC oscillator, wherein the capacitance of the applied pressure introduced by the sensor surfaces is a parallel capacitance in the RC circuit such that, when the capacitance of the applied pressure is present, the overall capacitance of the RC circuit is altered. The RC oscillator operates at a set frequency controlled by the capacitance of the RC circuit. The sensor surfaces deform due to applied pressure, and, consequently, the capacitance of the deformation due to applied pressure is introduced to the RC circuit by a connection between the sensor surfaces and the RC circuit such that the capacitance of the applied pressure is a parallel capacitance to the RC circuit. The change in overall capacitance of the RC circuit changes the frequency of the RC oscillator, thus, indicating deformation due to applied pressure to the sensor surfaces.

**[0087]** In some embodiments, the frequency of the RC oscillator is compared to a reference value to determine if a change in frequency occurs; therefore, deformation due to applied pressure is detected. Accordingly, three alternatives are presented for performing the comparison between the reference value and the frequency of the RC oscillator. One alternative is to define the reference value as a frequency equivalent to the operating frequency of the RC oscillator when the applied pressure is not excessive. In this instance, the reference value and the frequency of the RC oscillator are both input into a frequency comparator, wherein the frequency comparator evaluates if the values are similar; and thus, indicating one way or the other.



[0088] Optionally, the second alternative for comparison of the reference value and the frequency of the RC oscillator comprises a frequency-to-voltage converter, a DC voltage reference value, and a comparator, wherein the frequency of the RC oscillator is input to the frequency-to-voltage converter and a voltage corresponding to the frequency is output. The comparator compares the output voltage of the frequency-to-voltage converter to the DC voltage reference value. The DC voltage reference value is equivalent to the output voltage of the frequency-to-voltage converter when the applied pressure is not excessive. Accordingly, the comparator outputs a signal consistent with whether the DC voltage reference value is similar to the output of the frequency-to-voltage converter.

[0089] Optionally, the third alternative for comparison of the reference value and the frequency of the RC oscillator is to directly measure the frequency of the signal by counting the number of rising or falling edges in a defined time period utilizing a device similar to a microcontroller. In this manner, a baseline operating frequency may be established, and any deviation in frequency beyond a defined threshold will indicate the applied pressure is excessive.

[0090] In some embodiments, the voltage divider parallel plate capacitive sensor comprises at least two conductive sensor surfaces, which provides an analog input; an intermediary insulator; a reference voltage; an analog-to-digital converter (A/DC); and a A/DC capacitor. The A/DC is internally driven to the reference voltage such that the A/DC capacitor is fully charged, and the analog input of the conductive sensor surfaces is internally grounded such that the sensor surfaces are fully discharged. Next, the analog input of the sensor surfaces is internally disconnected from the ground and is internally connected to the A/DC such that the A/DC capacitor will discharge at least a portion of its charge to the sensor surfaces in order to equal the voltages of the sensor surfaces and the A/DC capacitor. If the applied pressure causing

deformation is excessive, the sensor will appear to have a larger capacitance. Said larger capacitance results in a many time smaller steady-state voltage between the A/DC capacitor and the sensor as compared to the condition when the sensor is in its normal, low capacitance state. The A/DC may measure the analog input and compare it to a threshold to determine if the sensor surfaces are excessively deformed due to applied pressure. The voltage provided to the A/DC will decrease in a manner indicative of the deformation due to excessive applied pressure to the sensor surface. In some embodiments, the decrease in a manner indicative of the deformation due to excessive applied pressure is significant.

[0091] In some embodiments, the reference voltage, the A/DC, and the A/DC capacitor are comprised in a microcontroller such that circuit comprises at least two conductive sensor surfaces with an analog input and an intermediary insulator connected to the microcontroller. The A/DC of the microcontroller converts the voltage provided to the A/DC from an analog signal to a digital signal. The microcontroller determines whether the applied pressure is excessive based on the digital signal.

[0092] In some embodiments where the implement is a toothbrush **10**, the bristles **25** comprised in the brush head are operatively attached to at least one of the parallel plates, wherein applied pressure may be detected by the force exerted by the bristles **25** on the brush head.

[0093] In some embodiments, the oral health care implement further comprises at least one temperature sensor **120** having a detector and a transmitter. The temperature sensor **120** is chosen from the group thermocouple, thermistor, resistance temperature detector (RTD), infrared temperature sensor, thermopile, thermostat, and silicon bandgap temperature sensor.

[0094] In some embodiments, the transmitter of the temperature sensor **120** is an electrically conductive wire, wherein the electrical output of the detector is input to the electrically

conductive wire and transmitted thereon. The electrical output of the detector is, otherwise, referred to as the signal indicative of the temperature captured by the detector of the temperature sensor **120**. The electrically conductive wire allows for the transmission of the signal indicative of the temperature.

[0095] In some embodiments, the detector of the temperature sensor **120** is at least one thermocouple, wherein the thermocouple comprises two different conductors, typically metal alloys, that produce a voltage proportional to a temperature difference between either end of the pair of conductors. Optionally, in some embodiments, the detector of the temperature sensor **120** is at least one thermistor, wherein the thermistor is a resistor that has a certain resistance, which varies significantly with temperature. Thermistors are generally comprised of a ceramic or polymer material.

[0096] Optionally, in some embodiments, the detector of the temperature sensor **120** is at least one resistance temperature detector (RTD), wherein the RTD exploits a predictable change in electrical resistance that is dependent upon a change in temperature. In some embodiments, the material of the RTD is platinum. Optionally, in some embodiments, the detector of the temperature sensor **120** is at least one infrared temperature sensor, wherein the temperature of an object is determined by a portion of thermal radiation referred to as blackbody radiation emitted by the object, such that knowing the infrared energy emitted and the object's emissivity allows for the determination of the object's temperature.

[0097] Optionally, in some embodiments, the detector of the temperature sensor **120** is at least one thermopile, wherein the thermopile converts thermal energy into electrical energy and is comprised of one or more thermocouples connected in series or parallel. Optionally, in some embodiments, the detector of the temperature sensor **120** is at least one thermostat, wherein the

thermostat comprises two different metals that are bonded together to form a bi-metallic strip, such that the difference in linear expansion rates causes a mechanical bending movement when heat is applied. Optionally, in some embodiments, the detector of the temperature sensor **120** is at least one silicon bandgap temperature sensor, wherein the forward voltage of a silicon diode is dependent on temperature, and the temperature is determined by comparing bandgap voltages at two different currents.

**[0098]** In some embodiments, the temperature sensor **120** and the data processing unit **31**, both of the implement, operate in conjunction to provide data indicative of user core body temperature, wherein user core body temperature is a user's operating temperature, which can be indicative of problems experienced by the user. The detector of the temperature sensor **120** detects the temperature within the oral cavity and the transmitter transmits a signal indicative of temperature. The collector of the data processing unit **31** receives the signal indicative of temperature, and the storage medium of the data processing unit **31** stores the signal indicative of temperature in the form of data indicative of temperature. The processor of the data processing unit **31** processes the stored data indicative of temperature into data indicative of user core body temperature, and the storage medium of the data processing unit stores the data indicative of user core body temperature.

**[0099]** In some embodiments, the oral health care implement further comprises a pH sensor having a detector and a transmitter. The detector of the pH sensor comprises a reference electrode, which does not change potential with changes in hydrogen ion concentration, and a measuring electrode, which completes the circuit with the test solution, such that the measuring electrode detects changes in the concentration of hydrogen ions. The detector further comprises

a preamplifier that converts high-impedance pH electrode signals into low-impedance pH electrode signals that can be accepted by the transmitter.

**[0100]** In some embodiments, the transmitter of the pH sensor is an electrically conductive wire, wherein the electrical output of the detector is input to the electrically conductive wire and transmitted thereon. The electrical output of the detector is, otherwise, referred to as the signal indicative of the pH value captured by the detector of the pH sensor. The electrically conductive wire allows for the transmission of the signal indicative of the pH value.

**[0101]** In some embodiments, pH value is a measure of the acidity or basicity of an aqueous solution, wherein pure water is neutral. A pH value is a number within the limits of the pH scale, which has a range of 0 to 14. Pure water has a pH value of 7, which is the center of the pH scale. A solution with a pH value less than 7 is acidic, and a solution with a pH value greater than 7 is basic or alkaline.

**[0102]** In some embodiments, the pH value of oral fluid is of interest such that certain pH values can be indicative of certain conditions and disease states. Accordingly, in some embodiments, oral fluid is characterized as a combination of saliva and oral mucosal transudate. Saliva is a fluid secreted from the salivary glands of a human and is comprised of mostly water and smaller amounts of electrolytes, mucus, antibacterial compounds, and various enzymes. Oral mucosal transudate is fluid created from the passive transport of serum components through the oral mucosa into the mouth. In some embodiments, oral fluid is a useful source for diagnostic testing.

**[0103]** In some embodiments, the oral health care implement further comprises at least one microfluidic channel, wherein said microfluidic channel collects oral fluid. A microfluidic channel is characterized as having at least one solid side configured to create a depression in a

solid surface such that the microfluidic channel can retain collected fluid; the collected fluid is oral fluid, in some embodiments. The microfluidic channel is further characterized as handling small fluid volumes including volumes less than Pico liters. In operation, the microfluidic channel is placed in contact with a targeted fluid, such as oral fluid, which is drawn into the microfluidic channel by the process of capillary action. Advantageously, the microfluidic channel provides faster analysis and response times due to shorter diffusion distances, fast heating, and high surface-to-volume ratios.

**[0104]** Additionally, in some embodiments, the microfluidic channel of the implement collects oral fluid and delivers oral fluid to the detector of the pH sensor. The oral fluid is collected by the microfluidic channel and is placed in contact with the detector of the pH sensor. The detector of the pH sensor detects the pH value of the oral fluid, and the transmitter of the pH sensor transmits a signal indicative of the pH value.

**[0105]** Further, in some embodiments, the oral health care implement comprises a diagnostic ultrasonic sensor **50** having a detector and a transmitter. In some embodiments, the detector of the diagnostic ultrasonic sensor **50** includes at least one ultrasonic transducer and at least one ultrasonic detector. The ultrasonic transducer converts energy into ultrasound and emits said ultrasound, which is sound waves above the normal audible range of human hearing, typically with a frequency of 20 MHz or greater. In some embodiments, the ultrasonic transducer is a piezoelectric transducer which converts electrical energy into ultrasound by applying an alternating current (AC) across piezoelectric material, which holds the property of changing size when a voltage is applied to it. The application of alternating current to piezoelectric material provides a high frequency oscillation of the piezoelectric material. Consequently, very high

frequency sound waves, ultrasound, are produced by the high frequency oscillation of the piezoelectric material.

**[0106]** Additionally, in some embodiments, the ultrasonic detector is a piezoelectric detector that receives ultrasonic waves causing the piezoelectric material to oscillate at a high frequency, thus producing an electrical voltage indicative of the frequency of the ultrasonic waves. In some embodiments, the piezoelectric transducer and the piezoelectric detector utilize the same body of piezoelectric material. Accordingly, the combined embodiment of the piezoelectric transducer and the piezoelectric detector is a piezoelectric transceiver, which performs the functions of both the piezoelectric transducer and the piezoelectric detector comprised in one singular body of piezoelectric material. Optionally, the piezoelectric transducer and the piezoelectric detector utilize separate bodies of piezoelectric material.

**[0107]** In some embodiments, the piezoelectric material is chosen from the group Quartz, Berlinite ( $\text{AlPO}_4$ ), Potassium sodium tartrate, Topaz ( $\text{Al}_2\text{SiO}_4(\text{F}, \text{OH})_2$ ), Gallium orthophosphate ( $\text{GaPO}_4$ ), Langasite ( $\text{La}_3\text{Ga}_5\text{SiO}_{14}$ ), Barium titanate ( $\text{BaTiO}_3$ ), Lead titanate ( $\text{PbTiO}_3$ ), Lead zirconate titanate ( $\text{Pb}[\text{Zr}_x\text{Ti}_{1-x}]\text{O}_3$ ,  $0 \leq x \leq 1$ ), Potassium niobate ( $\text{KNbO}_3$ ), Lithium niobate ( $\text{LiNbO}_3$ ), Lithium tantalite ( $\text{LiTaO}_3$ ), Sodium tungstate ( $\text{Na}_2\text{WO}_3$ ), Sodium potassium niobate ( $\text{NaKNb}$ ), Bismuth ferrite ( $\text{BiFeO}_3$ ), Sodium niobate ( $\text{NaNbO}_3$ ), and Polyvinylidene fluoride (PVDF).

**[0108]** Optionally, in some embodiments, the ultrasonic transducer is a magnetostrictive transducer comprising a magnetostrictive material, magnetizing coil, and magnetic enclosure, wherein the combination of the three elements completes a magnetic circuit. Magnetostrictive transducers utilize the magnetostrictive property of the magnetostrictive material to convert the magnetic energy of a magnetic field to ultrasound, which is sound waves above the normal

audible range of human hearing, typically with a frequency of 20 MHz or greater. The magnetostrictive property is a material property, common to ferromagnetic materials, where the material is divided into uniform magnetic polarization domains, such that when a magnetic field is applied said domains shift and rotate causing the magnetostrictive material to change size at a high frequency, thus generating high frequency sound waves or ultrasound. In a magnetostrictive transducer, the magnetic field, in some embodiments, is provided by the magnetizing coil wrapped around the magnetostrictive material. The magnetic field of the magnetizing coil is produced by the input of electrical energy into the coil.

**[0109]** Additionally, in some embodiments, the ultrasonic detector is a magnetostrictive detector comprising a magnetostrictive material, magnetizing coil, and magnetic enclosure, wherein the combination of the three elements completes a magnetic circuit. In the same manner as the magnetostrictive transducer, the magnetostrictive detector utilizes the magnetostrictive property of the magnetostrictive material to convert ultrasound to magnetic energy, which alters the magnetic field of the magnetizing coil, thus altering the electrical energy output of the magnetostrictive detector.

**[0110]** In some embodiments, the magnetostrictive material is chosen from the group Cobalt, Terfenol-D, and Metglas 2605SC. In some embodiments, the magnetizing coil is manufactured from an electrically conductive material. Additionally, in some embodiments, the magnetostrictive transducer and the magnetostrictive detector utilize the same magnetostrictive material, magnetizing coil, and magnetic enclosure, consequently embodied as a magnetostrictive transceiver. Optionally, the magnetostrictive transducer and the magnetostrictive detector have separate magnetostrictive materials, magnetizing coils, and magnetic enclosures.



[0111] Optionally, in some embodiments, the ultrasonic transducer is a capacitive actuator comprising two conductive plates on either side of a dielectric material, wherein electrical energy is passed from one conductive plate through the dielectric material to the second conductive plate. The passing of electrical energy across the conductive plates causes the conductive plates to acquire opposite charges, which further causes an attractive force to exist between the conductive plates. Electrical energy in the form of alternating current provides high frequency oscillation of the capacitive actuator, thus converting electrical energy into ultrasound.

[0112] Additionally, in some embodiments, the ultrasonic detector is a capacitive actuator having the same properties as stated above. The process is reversed in the instance of the ultrasonic detector, such that ultrasound is received that affects the oscillation of the capacitive actuator, and the electrical energy passed between the two conductive plates through the dielectric material is altered as a result.

[0113] Optionally, in some embodiments, the ultrasonic detector comprises a waveguide, wherein the ultrasonic wave is emitted into the waveguide where the sound wave is propagated onto a surface. Optionally, the waveguide comprises at least one toothbrush bristle such that it is included in the plurality of existing toothbrush bristles **25**.

[0114] In some embodiments, the transmitter of the diagnostic ultrasonic sensor **50** is an electrically conductive wire, wherein the electrical output of the detector is input to the electrically conductive wire and transmitted thereon. The electrical output of the detector is, otherwise, referred to as the signal indicative of the condition captured by the detector of the diagnostic ultrasonic sensor **50**. The electrically conductive wire allows for the transmission of the signal indicative of the condition.

[0115] In some embodiments, the detector of the diagnostic ultrasonic sensor **50** detects at least one condition within the oral cavity of a user. The condition detected by the detector of the diagnostic ultrasonic sensor **50** is indicative of at least a portion of the user's oral health. In some embodiments, the condition is chosen from the group biofilm thickness, plaque, gingivitis, and periodontitis.

[0116] In some embodiments, the diagnostic ultrasonic sensor **50** is a microelectromechanical system (MEMS). A microelectromechanical system is characterized as a system comprising miniaturized mechanical and electro-mechanical elements that are fabricated using the techniques of microfabrication. A microelectromechanical system is further characterized as comprising miniaturized structures, referred to as microstructures; miniaturized sensors, referred to as microsensors; miniaturized actuators, referred to as microactuators; and microelectronics. Microsensors and microactuators are commonly referred to as microtransducers, which are miniaturized devices that convert energy from one medium to another, such as mechanical to electrical.

[0117] In some embodiments, microelectromechanical systems vary in size from about less than one micron – one micron is one thousandth of a millimeter – to about greater than one millimeter. The relatively miniature size of microelectromechanical systems requires the utilization of certain materials better suited for fabrication at the defined scale. In some embodiments, the materials used for fabrication of microelectromechanical systems are chosen from the group silicon, polymers, metals, and ceramics. Additionally, in some embodiments, the metals used for fabrication are chosen from the group gold, nickel, aluminum, copper, chromium, titanium, tungsten, platinum, and silver.

[0118] Accordingly, a plurality of fabrication processes exist for the production of microelectromechanical systems including: deposition processes, patterning processes, and etching processes. Further, in some embodiments, deposition processes to fabricate microelectromechanical systems are chosen from the group physical vapor deposition, sputtering, chemical deposition, chemical vapor deposition, low pressure chemical vapor deposition, plasma enhanced chemical vapor deposition, and thermal oxidation. Further still, in some embodiments, patterning processes to fabricate microelectromechanical systems are chosen from the group Lithography, Photolithography, electron beam lithography, ion beam lithography, and x-ray lithography. In some embodiments, etching processes to fabricate microelectromechanical systems are chosen from the group wet etching, isotropic etching, anisotropic etching, hydrofluoric etching, electrochemical etching, vapor etching, and plasma etching.

[0119] In some embodiments, the ultrasonic detector receives ultrasonic waves reflected from each contacted surface within the oral cavity. Accordingly, in some embodiments, a contacted surface is characterized as a transition surface between two substantially different mediums such that the transition surface between biofilm on a tooth and enamel of said tooth creates a contacted surface. Additionally, contacted surfaces exist at the transition surfaces between oral fluid and biofilm; biofilm and enamel; enamel and dentin; dentin and pulp; pulp and cementum; and cementum and gums.

[0120] Optionally, in some embodiments, the power source 36 of the oral health care implement is a mechanical self-charging power source, wherein the power source is replenished by the mechanical motion of brushing a user's teeth. Accordingly, the mechanical motion of brushing a user's teeth is characterized as optimized cleaning motion commensurate with the

recommendations of at least one dental practitioner. In some embodiments, this motion is characterized as short back-and-forth motions performed in rapid succession such that biofilm is removed from the surface of teeth. Optionally, the power source **36** is replenished by the user shaking the implement apart from brushing of a user's teeth.

**[0121]** In some embodiments, the mechanical self-charging power source is at least one induction coil and at least one neodymium magnet, wherein the motion of the implement causes the magnet move along the induction coil, which converts the kinetic energy of the magnet into electrical energy. In some embodiments, the electrical energy created by the induction coil and magnet is stored in a rechargeable battery.

**[0122]** In some embodiments, the oral health care implement is a dedicated device utilized for detecting oximetry and transmitting at least one signal to the data processing unit, and no other purpose. A dedicated device comprises only a handle, an oximetry sensor contained at least partially within the distal end of the handle, a data processing unit, and a power source, wherein the dedicated device is not used for any secondary purpose; a secondary purpose being brushing teeth. In some embodiments, a dedicated device is marketed to detect oximetry with the oximetry sensor and transmit at least one signal to the data processing unit.

**[0123]** A plurality of embodiments comprise an oral health care system. In some embodiments, the oral health care system comprises an implement and a first data transfer medium **201**. In some embodiments, the implement of the oral health care system is the oral health care implement described in the plurality of embodiments comprising the oral health care implement. Accordingly, the implement of the oral health care system, in some embodiments, comprises a handle, an oximetry sensor **151**, a data processing unit **31**, a transmitter, and a power source **36**.

[0124] In some embodiments, the first data transfer medium **201** of the oral health care system comprises a receiver and a data processing unit. The data processing unit of the first data transfer medium is consistent with the data processing unit **31** of the oral health care implement. Accordingly, in some embodiments, the data processing unit is chosen from the group microprocessor, microcontroller, field programmable gate array (FPGA), digital signal processing unit (DSP), application specific integrated circuit (ASIC), programmable logic, and combinations thereof.

[0125] Additionally, in some embodiments, the collector of the data processing unit is an electrically conductive wire, wherein the electrically conductive wire receives the electrical output of the receiver of the first data transfer medium, such that the electrical output of the receiver of the first data transfer medium is at least one signal indicative of oximetry.

[0126] Moreover, in some embodiments, the storage medium of the data processing unit is comprised of volatile memory and non-volatile memory, wherein volatile memory is used for short-term storage and processing, and non-volatile memory is used for long-term storage. Accordingly, in some embodiments, volatile memory is chosen from the group random-access memory (RAM), dynamic random-access memory (DRAM), double data rate synchronous dynamic random-access memory (DDR SDRAM), static random-access memory (SRAM), thyristor random-access memory (T-RAM), zero-capacitor random-access memory (Z-RAM), and twin transistor random-access memory (TTRAM). Optionally, in some embodiments, non-volatile memory is chosen from the group read-only memory (ROM), programmable read-only memory (PROM), erasable programmable read-only memory (EPROM), electrically erasable programmable read-only memory (EEPROM), flash memory, ferroelectric random-access memory (FeRAM), magnetoresistive random-access memory (MRAM), phase-change memory

(PRAM), conductive-bridging random-access memory (CBRAM), silicon-oxide-nitride-oxide-silicon memory (SONOS), resistive random-access memory (RRAM), racetrack memory, nano-random-access memory (NRAM), and Millipede memory.

[0127] Further still, in some embodiments, the processor of the data processing unit is chosen from the group microprocessor and microcontroller.

[0128] Additionally, in some embodiments, the receiver of the first data transfer medium **201** is chosen from the group universal serial bus (USB), serial port, wired Ethernet port, radio frequency, microwave communication, infrared short-range communication, near field communication, and Bluetooth. The receiver of the first data transfer medium **201** receives at least one signal indicative of oximetry from the data extractor of the oral health care implement.

[0129] In some embodiments, a signal indicates data as a measurable quantity relevant to oximetry detected by the detector of the oximetry sensor and is in a form chosen from the group digital and analog. The signal is further characterized as capable of being transmitted, received, collected, stored, processed, and displayed.

[0130] Optionally, in some embodiments, data is characterized as qualitative or quantitative attributes of at least one variable, such as oximetry. Data is further characterized as able to be encoded into at least one signal for transmitting, receiving, collecting, storing, processing, and displaying of data. Data is capable of being collected, stored, and processed.

[0131] In some embodiments, the first data transfer medium **201** is a personal computer system **259**, which is any general-purpose computer with a size and capability conducive to direct operation by an end-user. Optionally, the first data transfer medium **201** is a dental office computer system **264**, which is any computer primarily used in a dental office for dental care purposes. Optionally, in some embodiments, the first data transfer medium **201** is a tablet

personal computer **285**, wherein the display medium and user input medium are comprised in a singular flat touch screen, and the tablet personal computer **285** is a complete mobile computing system.

[0132] Optionally, in some embodiments, the first data transfer medium **201** is a mobile communication device **272** capable of receiving and transmitting telephone calls. Optionally, in some embodiments, the first data transfer medium **201** is a dedicated system **277** utilized only for the purposes set out for the first data transfer medium **201**. Optionally, in some embodiments, the first data transfer medium **201** is a television **253**. Additionally, in some embodiments, the first data transfer medium **201** is an external charging station **308** that replenishes the electrical energy of the power source of the implement.

[0133] Optionally, in some embodiments, the first data transfer medium **201** is a network router **291** that forwards data packets between telecommunications networks, e.g. between the Internet and a personal computer. Optionally, in some embodiments, the first data transfer medium **201** is a web-enabled network storage device **299** that is connected to the internet and acts as a database, commonly referred to as the “Cloud.”

[0134] In some embodiments, the first data transfer medium **201** further comprises a transmitter. Optionally, the transmitter of the first data transfer medium **201** is chosen from the group universal serial bus (USB), serial port, wired Ethernet port, radio frequency, microwave communication, infrared short-range communication, near field communication, and Bluetooth.

[0135] In some embodiments, the first data transfer medium **201** further comprises a display, wherein the display converts signals into a user-readable format **401**. The user-readable format **401** is characterized as a format that allows a user to easily determine the measurement from the display device. In some embodiments, the user-readable format **401** is Arabic numerals.

[0136] In some embodiments, the first data transfer medium **201** further comprises a user interface **427** for product selection and purchase options. The user interface **427**, in some embodiments, is embodied in the display such that the user interface **427** can be viewed and manipulated using the display. Optionally, the user interface **427** is manipulated through at least one medium external to the display. Alternatively, the user interface **427** is manipulated using the display and at least one medium external to the display. Additionally, the user interface **427** allows for product selection from an online catalog of products. In some embodiments, the online catalog of products is comprised primarily of dental products. The display shows the products of the online catalog in a form chosen from the group at least one image, at least one description, at least one title, at least one price, at least one product review, and any combination thereof. In some embodiments, the user interface **427** allows for the browsing of a plurality of products contained in the online catalog.

[0137] Additionally, in some embodiments, the user interface **427** further comprises display space for advertising of products relevant to the user. In some embodiments, data collected by the implement and transmitted to the first data transfer medium **201** is utilized to determine products relevant to the user, e.g. a user who had a high concentration of biofilm thickness would receive an advertisement for a mouthwash intended to breakdown biofilm.

[0138] Further, in some embodiments, the user interface **427** presents purchase options on the display, such that a user can view a product and choose at least one option for purchasing the product. The purchase options perform an action chosen from the group add the product to an online cart, purchase the product directly, direct the user to a separate page to purchase the product, direct to a separate page of price comparisons between retailers, direct to a separate page of physical retailers offering the item, and any combination thereof.



[0139] Reiterating, in some embodiments, the user interface **427** presents a plurality of dental products from at least one online catalog on the display of the first data transfer medium **201**, wherein the user browses products for product selection and purchases products utilizing the purchasing options.

[0140] In some embodiments, the user interface **427** facilitates the user's participation in social games related to the data collected by the sensors of the implement. Participation in said social games is accomplished passively through the collection of data by the sensors of the implement over a period of time, rather than participation by real-time user input. Optionally, the social games consist of goals to be accomplished, competitive games between multiple users or between a singular user and a computer generated user, and challenges to complete specified milestones.

[0141] Participation in social games is accomplished through a plurality of different user groups. The first user group for participation is a closed loop user group, which is accomplished on a specific data transfer medium and participation is limited to the users of said specific data transfer medium. The second user group for participation is a networked user group, which is accomplished over a network that connects a plurality of data transfer mediums. Networked user groups are further defined as including users belonging to a certain group defined through social media or other means. The third user group for participation is a global user group, which is a user group that anyone can join and participate in. The global user group, in some embodiments, may be sponsored or promoted by a particular entity as a form of advertisement or incentive to the users of the global user group.

[0142] Participation in social games may be incentivized with an offered reward to encourage participation of members of a user group. Rewards may include coupons, discounts

on goods or services, virtual currency, insurance discounts, and customized incentives. Rewards have the advantage of being given based off of passive data collected by sensors, thus rewarding users for health compliance and health statistics.

**[0143]** In some embodiments, the oral health care system further comprises a second data transfer medium **211** that comprises a receiver, a transmitter, and a data processing unit. The data processing unit of the second data transfer medium **211** is consistent with the data processing unit **31** of the oral health care implement. Accordingly, in some embodiments, the data processing unit is chosen from the group microprocessor, microcontroller, field programmable gate array (FPGA), digital signal processing unit (DSP), application specific integrated circuit (ASIC), programmable logic, and combinations thereof.

**[0144]** Additionally, in some embodiments, the collector of the data processing unit is an electrically conductive wire, wherein the electrically conductive wire receives the electrical output of the receiver of the second data transfer medium, such that the electrical output of the receiver of the second data transfer medium is at least one signal indicative of oximetry.

**[0145]** Moreover, in some embodiments, the storage medium of the data processing unit is comprised of volatile memory and non-volatile memory, wherein volatile memory is used for short-term storage and processing, and non-volatile memory is used for long-term storage. Accordingly, in some embodiments, volatile memory is chosen from the group random-access memory (RAM), dynamic random-access memory (DRAM), double data rate synchronous dynamic random-access memory (DDR SDRAM), static random-access memory (SRAM), thyristor random-access memory (T-RAM), zero-capacitor random-access memory (Z-RAM), and twin transistor random-access memory (TTRAM). Optionally, in some embodiments, non-volatile memory is chosen from the group read-only memory (ROM), programmable read-only

memory (PROM), erasable programmable read-only memory (EPROM), electrically erasable programmable read-only memory (EEPROM), flash memory, ferroelectric random-access memory (FeRAM), magnetoresistive random-access memory (MRAM), phase-change memory (PRAM), conductive-bridging random-access memory (CBRAM), silicon-oxide-nitride-oxide-silicon memory (SONOS), resistive random-access memory (RRAM), racetrack memory, nano-random-access memory (NRAM), and Millipede memory.

**[0146]** Further still, in some embodiments, the processor of the data processing unit is chosen from the group microprocessor and microcontroller.

**[0147]** Additionally, in some embodiments, the receiver of the second data transfer medium **211** is chosen from the group universal serial bus (USB), serial port, wired Ethernet port, radio frequency, microwave communication, infrared short-range communication, near field communication, and Bluetooth.

**[0148]** In some embodiments, the second data transfer medium **211** is a personal computer system **259**, which is any general-purpose computer with a size and capability conducive to direct operation by an end-user. Optionally, the second data transfer medium **211** is a dental office computer system **264**, which is any computer primarily used in a dental office for dental care purposes. Optionally, in some embodiments, the second data transfer medium **211** is a tablet personal computer **285**, wherein the display medium and user input medium are comprised in a singular flat touch screen, and the tablet personal computer **285** is a complete mobile computing system.

**[0149]** Optionally, in some embodiments, the second data transfer medium **211** is a mobile communication device **272** capable of receiving and transmitting telephone calls. Optionally, in some embodiments, the second data transfer medium **211** is a dedicated system **277** utilized only

for the purposes set out for the second data transfer medium **211**. Optionally, in some embodiments, the second data transfer medium **211** is a television **253**. Additionally, in some embodiments, the second data transfer medium **211** is an external charging station **308** that replenishes the electrical energy of the power source of the implement.

[0150] Optionally, in some embodiments, the second data transfer medium **211** is a network router **291** that forwards data packets between telecommunications networks, e.g. between the Internet and a personal computer. Optionally, in some embodiments, the second data transfer medium **211** is a web-enabled network storage device **299** that is connected to the internet and acts as a database, commonly referred to as the “Cloud.”

[0151] In some embodiments, the second data transfer medium **211** further comprises a transmitter. Optionally, the transmitter of the second data transfer medium **211** is chosen from the group universal serial bus (USB), serial port, wired Ethernet port, radio frequency, microwave communication, infrared short-range communication, near field communication, and Bluetooth.

[0152] In some embodiments, the second data transfer medium **211** further comprises a display, wherein the display converts signals into a user-readable format **401**. The user-readable format **401** is characterized as a format that allows a user to easily determine the measurement from the display device. In some embodiments, the user-readable format **401** is Arabic numerals.

[0153] In some embodiments, the second data transfer medium **211** further comprises a user interface **427** for product selection and purchase options. The user interface **427**, in some embodiments, is embodied in the display such that the user interface **427** can be viewed and manipulated using the display. Optionally, the user interface **427** is manipulated through at least

one medium external to the display. Alternatively, the user interface **427** is manipulated using the display and at least one medium external to the display. Additionally, the user interface **427** allows for product selection from an online catalog of products. In some embodiments, the online catalog of products is comprised primarily of dental products. The display shows the products of the online catalog in a form chosen from the group at least one image, at least one description, at least one title, at least one price, at least one product review, and any combination thereof. In some embodiments, the user interface **427** allows for the browsing of a plurality of products contained in the online catalog.

**[0154]** Additionally, in some embodiments, the user interface **427** further comprises display space for advertising of products relevant to the user. In some embodiments, data collected by the implement and transmitted to the first data transfer medium is utilized to determine products relevant to the user, e.g. a user who had a high concentration of biofilm thickness would receive an advertisement for a mouthwash intended to breakdown biofilm.

**[0155]** Further, in some embodiments, the user interface **427** presents purchase options on the display, such that a user can view a product and choose at least one option for purchasing the product. The purchase options perform an action chosen from the group add the product to an online cart, purchase the product directly, direct the user to a separate page to purchase the product, direct to a separate page of price comparisons between retailers, direct to a separate page of physical retailers offering the item, and any combination thereof.

**[0156]** Reiterating, in some embodiments, the user interface presents a plurality of dental products from at least one online catalog on the display of the second data transfer medium, wherein the user browses products for product selection and purchases products utilizing the purchasing options.

[0157] In some embodiments, the user interface 427 facilitates the user's participation in social games related to the data collected by the sensors of the implement. Participation in said social games is accomplished passively through the collection of data by the sensors of the implement over a period of time, rather than participation by real-time user input. Optionally, the social games consist of goals to be accomplished, competitive games between multiple users or between a singular user and a computer generated user, and challenges to complete specified milestones.

[0158] Participation in social games is accomplished through a plurality of different user groups. The first user group for participation is a closed loop user group, which is accomplished on a specific data transfer medium and participation is limited to the users of said specific data transfer medium. The second user group for participation is a networked user group, which is accomplished over a network that connects a plurality of data transfer mediums. Networked user groups are further defined as including users belonging to a certain group defined through social media or other means. The third user group for participation is a global user group, which is a user group that anyone can join and participate in. The global user group, in some embodiments, may be sponsored or promoted by a particular entity as a form of advertisement or incentive to the users of the global user group.

[0159] Participation in social games may be incentivized with an offered reward to encourage participation of members of a user group. Rewards may include coupons, discounts on goods or services, virtual currency, insurance discounts, and customized incentives. Rewards have the advantage of being given based off of passive data collected by sensors, thus rewarding users for health compliance and health statistics.

[0160] In some embodiments, the oral health care system further comprises a network storage device **246**, wherein the network storage device receives, stores, processes, and transmits data indicative of oximetry. The network storage device **246** is more commonly referred to, in some instances, as a network connected server. Additionally, in some instances, the network storage device **246** is more commonly referred to as a “Cloud” server, wherein the storage space on the server is paid for as a service.

[0161] In some embodiments, the network storage device **246** is connected to a network, wherein the network is chosen from the group Internet or intranet such that an intranet is a network managed and accessed by an internal organization and is not accessible to the outside world. The network is utilized by the network storage device **246** for receiving and transmitting data. The mode for receiving and transmitting data through the network is chosen from the group universal serial bus (USB), serial port, wired Ethernet port, radio frequency, microwave communication, infrared short-range communication, near field communication, and Bluetooth.

[0162] Additionally, in some embodiments, the network storage device **246** processes data using at least one microprocessor, at least one microcontroller, or a combination thereof. The storage of data, in some embodiments, is comprised of volatile memory and non-volatile memory, wherein volatile memory is used for short-term storage and processing, and non-volatile memory is used for long-term storage. Accordingly, in some embodiments, volatile memory is chosen from the group random-access memory (RAM), dynamic random-access memory (DRAM), double data rate synchronous dynamic random-access memory (DDR SDRAM), static random-access memory (SRAM), thyristor random-access memory (T-RAM), zero-capacitor random-access memory (Z-RAM), and twin transistor random-access memory (TTRAM). Optionally, in some embodiments, non-volatile memory is chosen from the group

read-only memory (ROM), programmable read-only memory (PROM), erasable programmable read-only memory (EPROM), electrically erasable programmable read-only memory (EEPROM), flash memory, ferroelectric random-access memory (FeRAM), magnetoresistive random-access memory (MRAM), phase-change memory (PRAM), conductive-bridging random-access memory (CBRAM), silicon-oxide-nitride-oxide-silicon memory (SONOS), resistive random-access memory (RRAM), racetrack memory, nano-random-access memory (NRAM), and Millipede memory.

[0163] The network storage device **246**, optionally, is a network server primarily used for storing and processing data. Optionally, the network storage device **246** is comprised of more than one network server such that the network servers operate in conjunction to increase the storing and processing capabilities of the network storage device **246**. In some embodiments, the network storage device **246** is provided as a service such that it is physically located at a location separate from the user, and the service provided is the storing and processing of data. In such embodiments, the network storage device **246** is sometimes referred to as the “Cloud.”

[0164] In some embodiments, the oral health care system further comprises a third data transfer medium **221** that comprises a receiver, a transmitter, and a data processing unit. The data processing unit of the third data transfer medium **221** is consistent with the data processing unit **31** of the oral health care implement. Accordingly, in some embodiments, the data processing unit is chosen from the group microprocessor, microcontroller, field programmable gate array (FPGA), digital signal processing unit (DSP), application specific integrated circuit (ASIC), programmable logic, and combinations thereof.

[0165] Additionally, in some embodiments, the collector of the data processing unit is an electrically conductive wire, wherein the electrically conductive wire receives the electrical



output of the receiver of the third data transfer medium, such that the electrical output of the receiver of the third data transfer medium is at least one signal indicative of oximetry.

**[0166]** Moreover, in some embodiments, the storage medium of the data processing unit is comprised of volatile memory and non-volatile memory, wherein volatile memory is used for short-term storage and processing, and non-volatile memory is used for long-term storage.

Accordingly, in some embodiments, volatile memory is chosen from the group random-access memory (RAM), dynamic random-access memory (DRAM), double data rate synchronous dynamic random-access memory (DDR SDRAM), static random-access memory (SRAM), thyristor random-access memory (T-RAM), zero-capacitor random-access memory (Z-RAM), and twin transistor random-access memory (TTRAM). Optionally, in some embodiments, non-volatile memory is chosen from the group read-only memory (ROM), programmable read-only memory (PROM), erasable programmable read-only memory (EPROM), electrically erasable programmable read-only memory (EEPROM), flash memory, ferroelectric random-access memory (FeRAM), magnetoresistive random-access memory (MRAM), phase-change memory (PRAM), conductive-bridging random-access memory (CBRAM), silicon-oxide-nitride-oxide-silicon memory (SONOS), resistive random-access memory (RRAM), racetrack memory, nano-random-access memory (NRAM), and Millipede memory.

**[0167]** Further still, in some embodiments, the processor of the data processing unit is chosen from the group microprocessor and microcontroller.

**[0168]** Additionally, in some embodiments, the receiver of the third data transfer medium **221** is chosen from the group universal serial bus (USB), serial port, wired Ethernet port, radio frequency, microwave communication, infrared short-range communication, near field communication, and Bluetooth.

[0169] In some embodiments, the third data transfer medium **221** is a personal computer system **259**, which is any general-purpose computer with a size and capability conducive to direct operation by an end-user. Optionally, the third data transfer medium **221** is a dental office computer system **264**, which is any computer primarily used in a dental office for dental care purposes. Optionally, in some embodiments, the third data transfer medium **221** is a tablet personal computer **285**, wherein the display medium and user input medium are comprised in a singular flat touch screen, and the tablet personal computer **285** is a complete mobile computing system.

[0170] Optionally, in some embodiments, the third data transfer medium **221** is a mobile communication device **272** capable of receiving and transmitting telephone calls. Optionally, in some embodiments, the third data transfer medium **221** is a dedicated system **277** utilized only for the purposes set out for the third data transfer medium **221**. Optionally, in some embodiments, the third data transfer medium **221** is a television **253**. Additionally, in some embodiments, the third data transfer medium **221** is an external charging station **308** that replenishes the electrical energy of the power source of the implement.

[0171] Optionally, in some embodiments, the third data transfer medium **221** is a network router **291** that forwards data packets between telecommunications networks, e.g. between the Internet and a personal computer. Optionally, in some embodiments, the third data transfer medium **221** is a web-enabled network storage device **299** that is connected to the internet and acts as a database, commonly referred to as the “Cloud.”

[0172] In some embodiments, the transmitter of the third data transfer medium **221** is chosen from the group universal serial bus (USB), serial port, wired Ethernet port, radio frequency,

microwave communication, infrared short-range communication, near field communication, and Bluetooth.

[0173] In some embodiments, the third data transfer medium **221** further comprises a display, wherein the display converts signals into a user-readable format **401**. The user-readable format **401** is characterized as a format that allows a user to easily determine the measurement from the display device. In some embodiments, the user-readable format **401** is Arabic numerals.

[0174] In some embodiments, the third data transfer medium **221** further comprises a user interface **427** for product selection and purchase options. The user interface **427**, in some embodiments, is embodied in the display such that the user interface **427** can be viewed and manipulated using the display. Optionally, the user interface **427** is manipulated through at least one medium external to the display. Alternatively, the user interface **427** is manipulated using the display and at least one medium external to the display. Additionally, the user interface **427** allows for product selection from an online catalog of products. In some embodiments, the online catalog of products is comprised primarily of dental products. The display shows the products of the online catalog in a form chosen from the group at least one image, at least one description, at least one title, at least one price, at least one product review, and any combination thereof. In some embodiments, the user interface **427** allows for the browsing of a plurality of products contained in the online catalog.

[0175] Additionally, in some embodiments, the user interface **427** further comprises display space for advertising of products relevant to the user. In some embodiments, data collected by the implement and transmitted to the first data transfer medium is utilized to determine products

relevant to the user, e.g. a user who had a high concentration of biofilm thickness would receive an advertisement for a mouthwash intended to breakdown biofilm.

[0176] Further, in some embodiments, the user interface **427** presents purchase options on the display, such that a user can view a product and choose at least one option for purchasing the product. The purchase options perform an action chosen from the group add the product to an online cart, purchase the product directly, direct the user to a separate page to purchase the product, direct to a separate page of price comparisons between retailers, direct to a separate page of physical retailers offering the item, and any combination thereof.

[0177] Reiterating, in some embodiments, the user interface **427** presents a plurality of dental products from at least one online catalog on the display of the third data transfer medium, wherein the user browses products for product selection and purchases products utilizing the purchasing options.

[0178] In some embodiments, the user interface **427** facilitates the user's participation in social games related to the data collected by the sensors of the implement. Participation in said social games is accomplished passively through the collection of data by the sensors of the implement over a period of time, rather than participation by real-time user input. Optionally, the social games consist of goals to be accomplished, competitive games between multiple users or between a singular user and a computer generated user, and challenges to complete specified milestones.

[0179] Participation in social games is accomplished through a plurality of different user groups. The first user group for participation is a closed loop user group, which is accomplished on a specific data transfer medium and participation is limited to the users of said specific data transfer medium. The second user group for participation is a networked user group, which is

accomplished over a network that connects a plurality of data transfer mediums. Networked user groups are further defined as including users belonging to a certain group defined through social media or other means. The third user group for participation is a global user group, which is a user group that anyone can join and participate in. The global user group, in some embodiments, may be sponsored or promoted by a particular entity as a form of advertisement or incentive to the users of the global user group.

**[0180]** Participation in social games may be incentivized with an offered reward to encourage participation of members of a user group. Rewards may include coupons, discounts on goods or services, virtual currency, insurance discounts, and customized incentives. Rewards have the advantage of being given based off of passive data collected by sensors, thus rewarding users for health compliance and health statistics.

**[0181]** Referring to Figure 13, a plurality of data transfer paths exist in the present embodiments. The data transfer paths are comprised of a combination of the elements of the oral health care system described, wherein the elements are chosen from the group implement, first data transfer medium **201**, second data transfer medium **211**, network storage device **246**, and third data transfer medium **221**. Accordingly, the simplest data transfer path is comprised of the implement and the first data transfer medium **201**, wherein the implement detects data and transmits data to the first data transfer medium **201**, which receives, stores and processes the data. Additionally, the first data transfer medium **201** may display data such that a user can view the data in a user-readable format **401**.

**[0182]** Optionally, the above embodiments exemplify data transfer paths of greater complexity. In some embodiments, the data transfer path comprises the implement, the first data transfer medium **201**, and the second data transfer medium **211**, wherein the implement detects

data and transmits data to the first data transfer medium **201**, which receives, stores, processes, and transmits the data to the second data transfer medium **211**. The second data transfer medium **211** receives, stores, and processes the data. The data is displayed in a user-readable format **401** by the first data transfer medium **201**, the second data transfer medium **211**, or a combination thereof.

[0183] Optionally, in some embodiments, the data transfer path comprises the implement, the first data transfer medium **201**, the second data transfer medium **211**, and the network storage device **246**. The implement detects data and transmits the data to the first data transfer medium **201**, and the first data transfer medium **201** receives, stores, processes, and transmits the data. The first data transfer data medium **201** transmits the data to the second data transfer medium **211**, wherein the second data transfer medium **211** receives, stores, processes, and transmits the data. The second data transfer medium **211** transmits the data to the network storage device **246**. The network storage device **246** receives, stores, and processes the data. The data is displayed in a user-readable **401** format by the first data transfer medium **201**, the second data transfer medium **211**, or a combination thereof.

[0184] Optionally, in some embodiments, the data transfer path comprises the implement, the first data transfer medium **201**, the second data transfer medium **211**, the network storage device **246**, and the third data transfer medium **221**. Accordingly, the implement detects data and transmits said data to the first data transfer medium **201**. The first data transfer medium **201** receives, stores, processes, and transmits the data, wherein the data is transmitted from the first data transfer medium **201** to the second data transfer medium **211**. Additionally, the second data transfer medium **211** receives, stores, processes, and transmits the data. The second data transfer medium **211** transmits the data, and the network storage device **246** receives the data, wherein

the network storage device **246** receives, stores, processes, and transmits the data. The third data transfer medium **221** receives the data transmitted by the network storage device **246**, and the third data transfer medium **221** receives, stores, processes, transmits, and displays the data.

Optionally, the data is displayed by a medium chosen from the group first data transfer medium **201**, second data transfer medium **211**, third data transfer medium **221**, and any combinations thereof. Additionally, data transmitted by the implement, the first data transfer medium **201**, the second data transfer medium **211**, the network storage device **246**, the third data transfer medium **221**, or any combination thereof may be received by the first data transfer medium **201**, the second data transfer medium **211**, the network storage device **246**, the third data transfer medium **221**, or any combination thereof.

[0185] Optionally, in some embodiments, the data transfer path comprises the implement, the first data transfer medium **201**, and the network storage device **246**. The implement detects data and transmits the data to the first data transfer medium **201**. The first data transfer medium **201** receives, stores, processes, and transmits the data. The first data transfer medium **201** transmits the data to the network storage device **246**, which receives, stores, processes, and transmits the data. Optionally, the first data transfer medium **201** displays the data in a user-readable format **401**.

[0186] Optionally, in some embodiments, the data transfer path comprises the implement, the first data transfer medium **201**, the network storage device **246**, and the third data transfer medium **221**. The implement detects data and transmits the data to the first data transfer medium **201**, which receives, stores, processes, and transmits the data. The first data transfer medium **201** transmits the data to the network storage device **246**, which receives, stores, processes, and transmits the data, where the data is transmits to the third data transfer medium **221**. The third

data transfer medium **221** receives, stores, processes, transmits, and displays the data.

Optionally, the first data transfer medium **201**, the third data transfer medium **221**, or any combinations thereof display the data in a user-readable format **401**.

**[0187]** In some embodiments, the oral health care system further comprises a robotic retrieval system (RRS), wherein the RRS retrieves and packages products ordered from a medium chosen from the group first data transfer medium **201**, second data transfer medium **211**, third data transfer medium **221**, and any combinations thereof. The RRS comprises at least one robotic system that is utilized to retrieve products purchased via the purchase options of the user interface **427**. In some embodiments, the user selects a product and purchases the product using the user interface **427** for product selection and purchase options. The purchase is transmitted to the RRS, which then locates the product within a distributor's warehouse and retrieves the product. The retrieved product is brought back to a packaging station where the RRS places the product in a package and prepares the package for shipment. In some embodiments, the user selects more than one product, and the RRS retrieves and packages multiple products in one order for shipment to the user.

**[0188]** It will be understood that the embodiments described herein are not limited in their application to the details of the teachings and descriptions set forth, or as illustrated in the accompanying figures. Rather, it will be understood that an oral health care implement and system with an oximetry sensor, as taught and described according to multiple embodiments disclosed herein, is capable of other embodiments and of being practiced or carried out in various ways.

**[0189]** Also, it is to be understood that the phraseology and terminology used herein is for the purpose of description and should not be regarded as limiting. The use herein of "including,"



“comprising,” “e.g.,” “containing,” or “having,” and variations of those words is meant to encompass the items listed thereafter, and equivalents of those, as well as additional items.

**[0190]** Accordingly, the descriptions herein are not intended to be exhaustive, nor are they meant to limit the understanding of the embodiments to the precise forms disclosed. It will be understood by those having ordinary skill in the art that modifications and variations of these embodiments are reasonably possible in light of the above teachings and descriptions.

## CLAIMS

What is claimed is:

1. An oral health care implement, comprising:
  - a handle having a distal end, a middle portion, and a proximal end;
  - an oximetry sensor having at least one light emitter and at least one photo detector and is configured to determine a condition of the user chosen from the group blood oxygen saturation, heart rate, and any combination thereof;
  - a data processing unit having a collector, a storage medium, and a processor; and
  - a power source,wherein the oximetry sensor is configured to transmit at least one signal indicative of oximetry to the data processing unit.
2. The oral health care implement of claim 1, wherein oral health care implement is chosen from the group toothbrush, flosser, floss pick, gum massager, tongue cleaner, interdental brush, prophy cup, scaler, mouth mirror, and any combination thereof.
3. The oral health care implement of claim 2, wherein the distal end of the handle is detachably connected to the remainder of the handle.
4. The oral health care implement of claim 1, further comprising at least one sensor chosen from the group diagnostic ultrasonic sensor, temperature sensor, pressure sensor, pH sensor, capacitive sensor, and any combination thereof.
5. The oral health care implement of claim 1, further comprising a data extractor.
6. The oral health care implement of claim 5, wherein the data extractor is chosen from the group universal serial bus, serial port, wired Ethernet port, radio frequency, microwave communication, infrared short-range communication, near field communication, and Bluetooth.

7. The oral health care implement of claim 5, wherein the oximetry sensor is chosen from the group transmissive pulse oximeter, reflective pulse oximeter, and any combination thereof.

8. The oral health care implement of claim 7, wherein the oximetry sensor further comprises a contact surface.

9. The oral health care implement of claim 8, wherein the contact surface of the reflective pulse oximeter is flush with at least a portion of the exterior surface of the handle.

10. The oral health care implement of claim 8, wherein at least a portion of the exterior surface of the handle is raised above the contact surface such that the contact surface is located in at least a partial depression.

11. The oral health care implement of claim 8, wherein the user contacts the contact surface during operation of the oral health care implement.

12. The oral health care implement of claim 8, further comprising at least one sensor chosen from the group diagnostic ultrasonic sensor, temperature sensor, pressure sensor, pH sensor, capacitive sensor, and any combination thereof.

13. The oral health care implement of claim 9, wherein the power source is a mechanical self-charging power source comprising at least one induction coil and at least one neodymium magnet, wherein the motion of the implement causes at least one neodymium magnet to move along at least one induction coil.

14. An oral health care system, comprising:

an implement having a handle; an oximetry sensor that is configured to detect a condition of the user chosen from the group blood oxygen saturation, heart rate, and any combination thereof; a data processing unit; a data extractor; and a power source, wherein the implement is used in the oral cavity; and

a first data transfer medium having a receiver that is configured to receive data indicative of oximetry and a data processing unit that is configured to store and process data indicative of oximetry.

15. The oral health care system of claim 14, wherein the first data transfer medium is configured to display data indicative of oximetry.

16. The oral health care system of claim 14, wherein the oximetry sensor of the implement is chosen from the group transmissive pulse oximeter, reflective pulse oximeter, and any combination thereof.

17. The oral health care system of claim 16, wherein the first data transfer medium is chosen from the group personal computer system, dental office computer system, mobile communication device, dedicated system, tablet personal computer, television, external charging station, network router, and web-enabled network storage device.

18. The oral health care system of claim 16, further comprising at least one sensor chosen from the group diagnostic ultrasonic sensor, temperature sensor, pressure sensor, pH sensor, capacitive sensor, and any combination thereof.

19. The oral health care system of claim 16, wherein the first data transfer medium further comprises a transmitter that is configured to transmit data indicative of oximetry.

20. The oral health care system of claim 19, wherein the first data transfer medium is configured to receive the signal indicative of oximetry and display a corresponding measurement in a user-readable format.

21. The oral health care system of claim 19, further comprising a second data transfer medium having a receiver that is configured to receive data indicative of oximetry, a transmitter

that is configured to transmit data indicative of oximetry, and a data processing unit that is configured to store and process data indicative of oximetry.

22. The oral health care system of claim 21, wherein the second data transfer medium is chosen from the group personal computer system, dental office computer system, mobile communication device, dedicated system, tablet personal computer, television, external charging station, network router, and web-enabled network storage device.

23. The oral health care system of claim 21, wherein the second data transfer medium is configured to receive the signal indicative of oximetry and display a corresponding measurement in a user-readable format.

24. The oral health care system of claim 21, further comprising a network storage device, wherein the network storage device is arranged to receive, store, process, and transmit data indicative of oximetry.

25. The oral health care system of claim 24, wherein the first data transfer medium further comprises a user interface for product selection and purchase options.

26. The oral health care system of claim 24, wherein the second data transfer medium further comprises a user interface for product selection and purchase options.

27. The oral health care system of claim 24, further comprising a third data transfer medium having a receiver that is configured to receive data indicative of oximetry, a transmitter that is configured to transmit data indicative of oximetry, and a data processing unit that is configured to store and process data indicative of proximity, wherein the third data transfer medium is configured to display data indicative of proximity.

28. The oral health care system of claim 27, wherein the third data transfer medium is chosen from the group personal computer system, dental office computer system, mobile

communication device, dedicated system, tablet personal computer, television, external charging station, network router, and web-enabled network storage device.

29. The oral health care system of claim 27, wherein the third data transfer medium is configured to receive the signal indicative of oximetry and display a corresponding measurement in a user-readable format.

30. The oral health care system of claim 27, wherein the third data transfer medium further comprises a user interface for product selection and purchase options.

31. The oral health care system of claim 19, further comprising a network storage device, wherein the network storage device is arranged to receive, store, process, and transmit data indicative of oximetry.

32. The oral health care system of claim 31, wherein the first data transfer medium further comprises a user interface for product selection and purchase options.

33. The oral health care system of claim 31, further comprising a third data transfer medium having a receiver that is configured to receive data indicative of oximetry, a transmitter that is configured to transmit data indicative of oximetry, and a data processing unit that is configured to store and process data indicative of oximetry, wherein the third data transfer medium is configured to display data indicative of oximetry.

34. The oral health care system of claim 33, wherein the third data transfer medium is chosen from the group personal computer system, dental office computer system, mobile communication device, dedicated system, tablet personal computer, television, external charging station, network router, and web-enabled network storage device.

35. The oral health care system of claim 33, wherein the third data transfer medium is configured to receive the signal indicative of oximetry and display a corresponding measurement in a user-readable format.

36. The oral health care system of claim 33, wherein the third data transfer medium further comprises a user interface for product selection and purchase options.

37. The oral health care system of claim 19, wherein the power source is a mechanical self-charging power source comprising at least one induction coil and at least one neodymium magnet, wherein the motion of the implement causes at least one neodymium magnet to move along at least one induction coil.

38. An oral health care system, comprising:

an implement having a handle; an oximetry sensor that is configured to detect a condition of the user chosen from the group blood oxygen saturation, heart rate, and any combination thereof; a data processing unit; a data extractor that is configured to transmit data indicative of proximity; and a power source, wherein the implement is used in the oral cavity; and

a first data transfer medium having a receiver that is configured to receive data indicative of oximetry, a data processing unit that is configured to store and process data indicative of oximetry, and a user interface that is configured to display data indicative of oximetry and to facilitate participation in social games such that participation is accomplished passively through data collection of the oximetry sensor of the implement over a period of time.

39. The oral health care system of claim 38, wherein the participation in social games further comprises incentives to encourage participation in social games and use of the implement.

40. The oral health care system of claim 38, wherein the first data transfer medium further comprises a transmitter that is configured to transmit data indicative of oximetry.

41. The oral health care system of claim 40, further comprising a second data transfer medium having a receiver that is configured to receive data indicative of oximetry, a transmitter that is configured to transmit data indicative of oximetry, a data processing unit that is configured to store and process data indicative of oximetry, and a user interface that is configured to display data indicative of oximetry and to facilitate participation in social games such that participation is accomplished passively through data collection of the oximetry sensor of the implement over a period of time.

42. The oral health care system of claim 41, wherein the participation in social games further comprises incentives to encourage participation in social games and use of the implement.



1/15

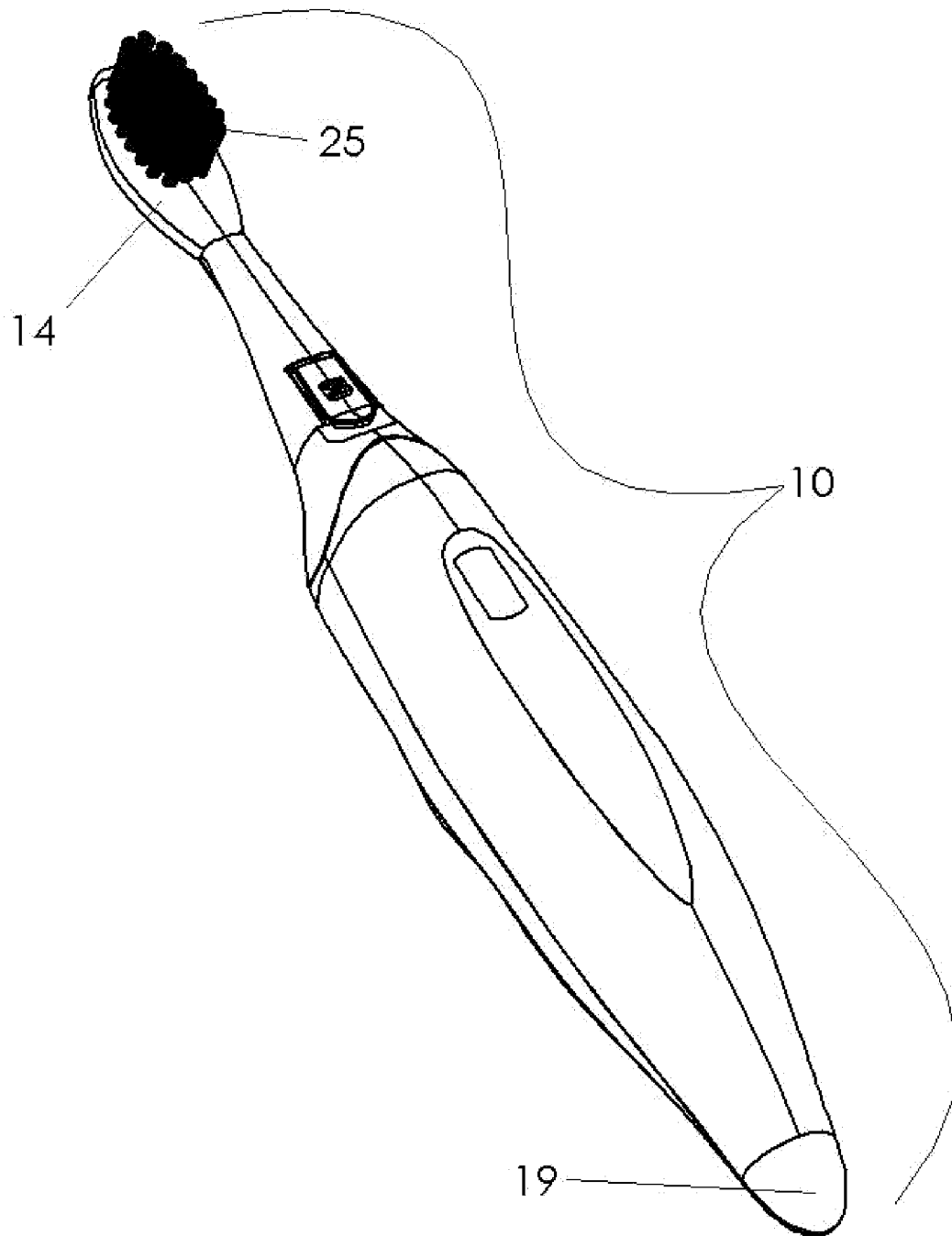

FIG. 1

2/15

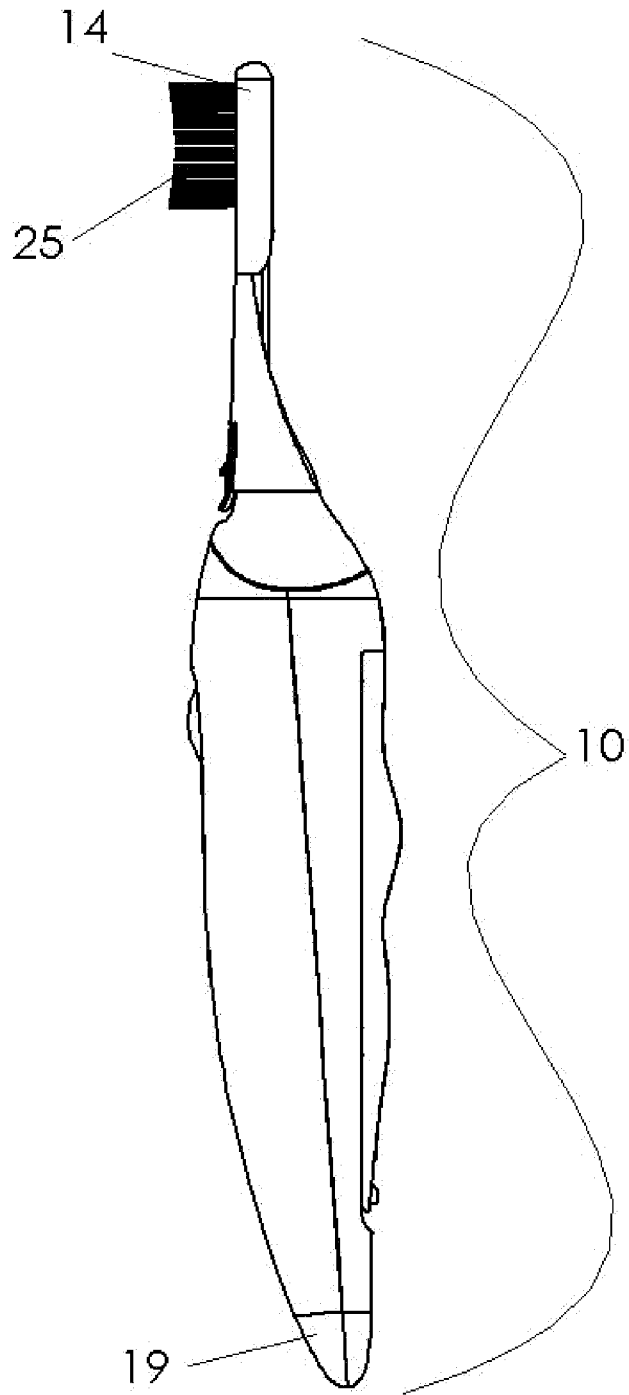

FIG. 2

3/15

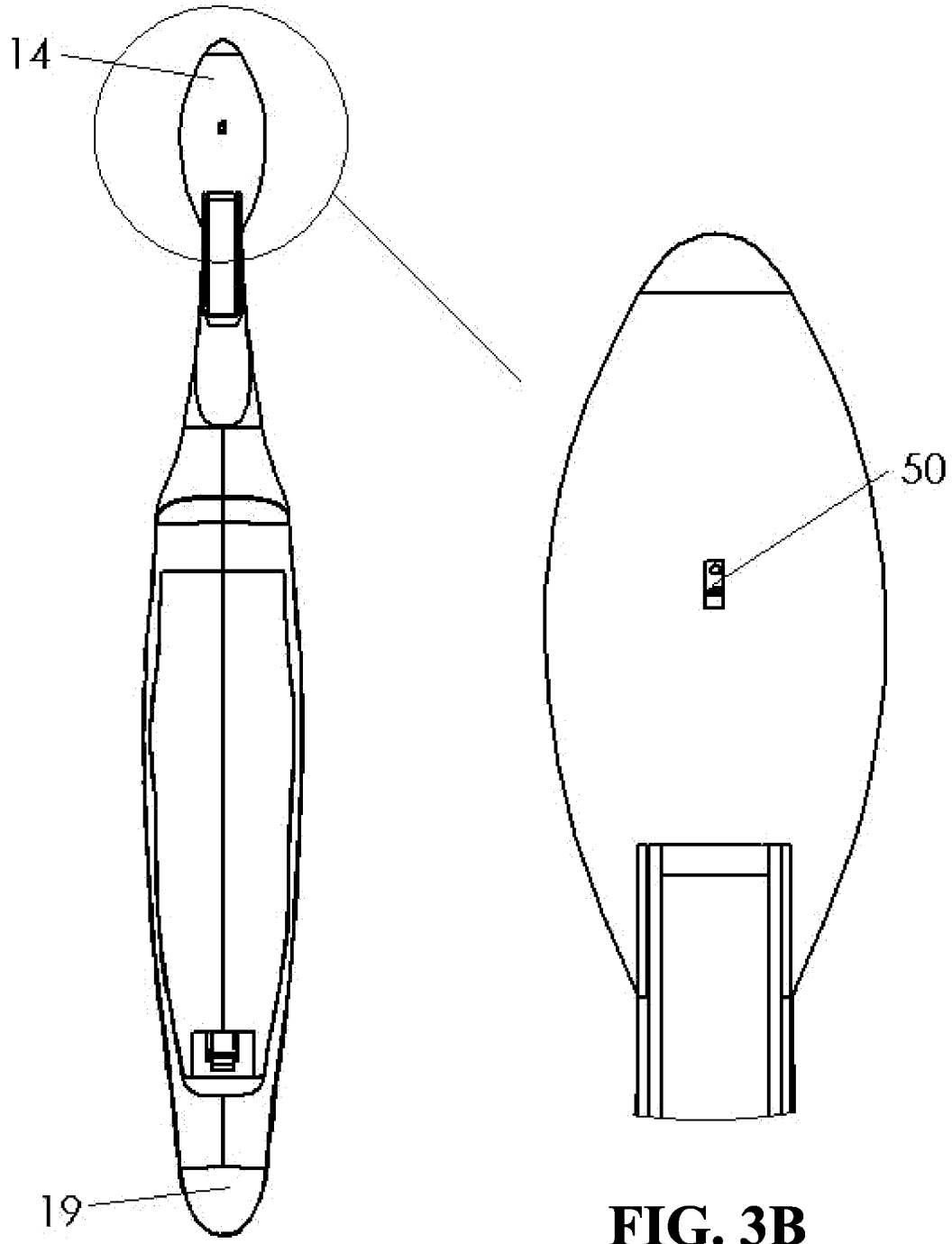

FIG. 3A

FIG. 3B

4/15

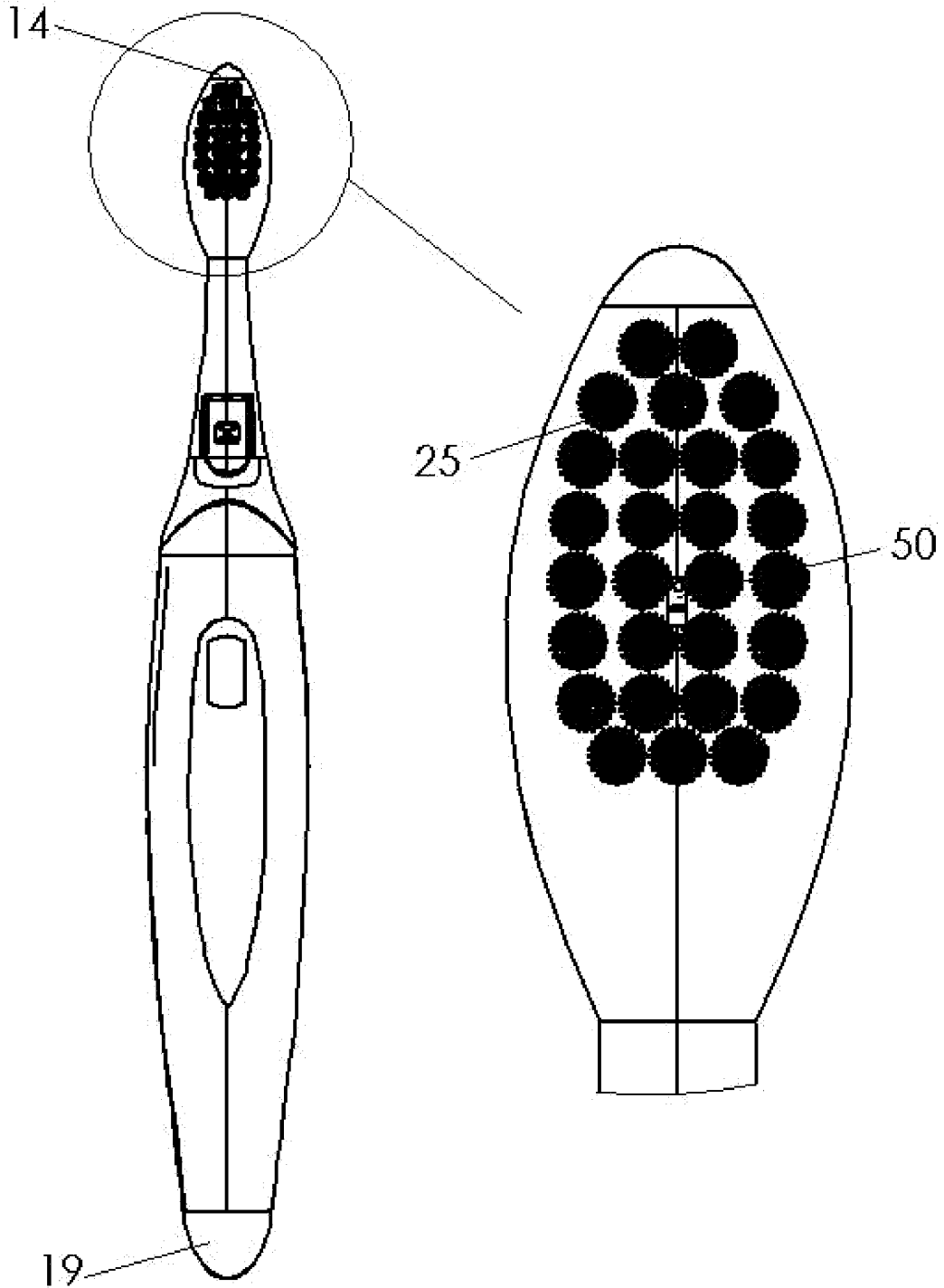

FIG. 4A

FIG. 4B

5/15

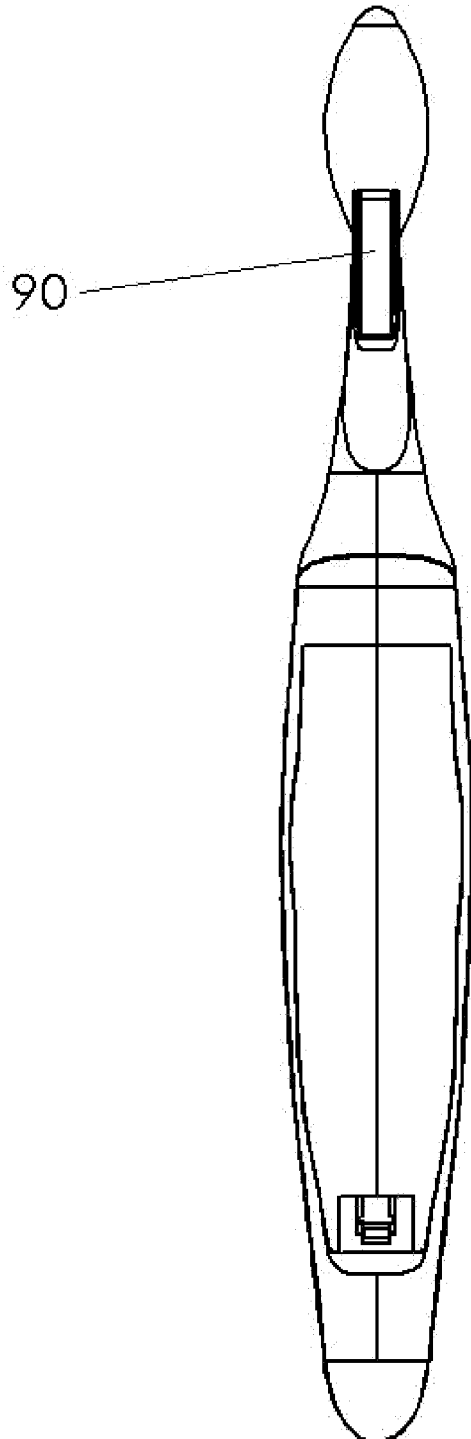

FIG. 5

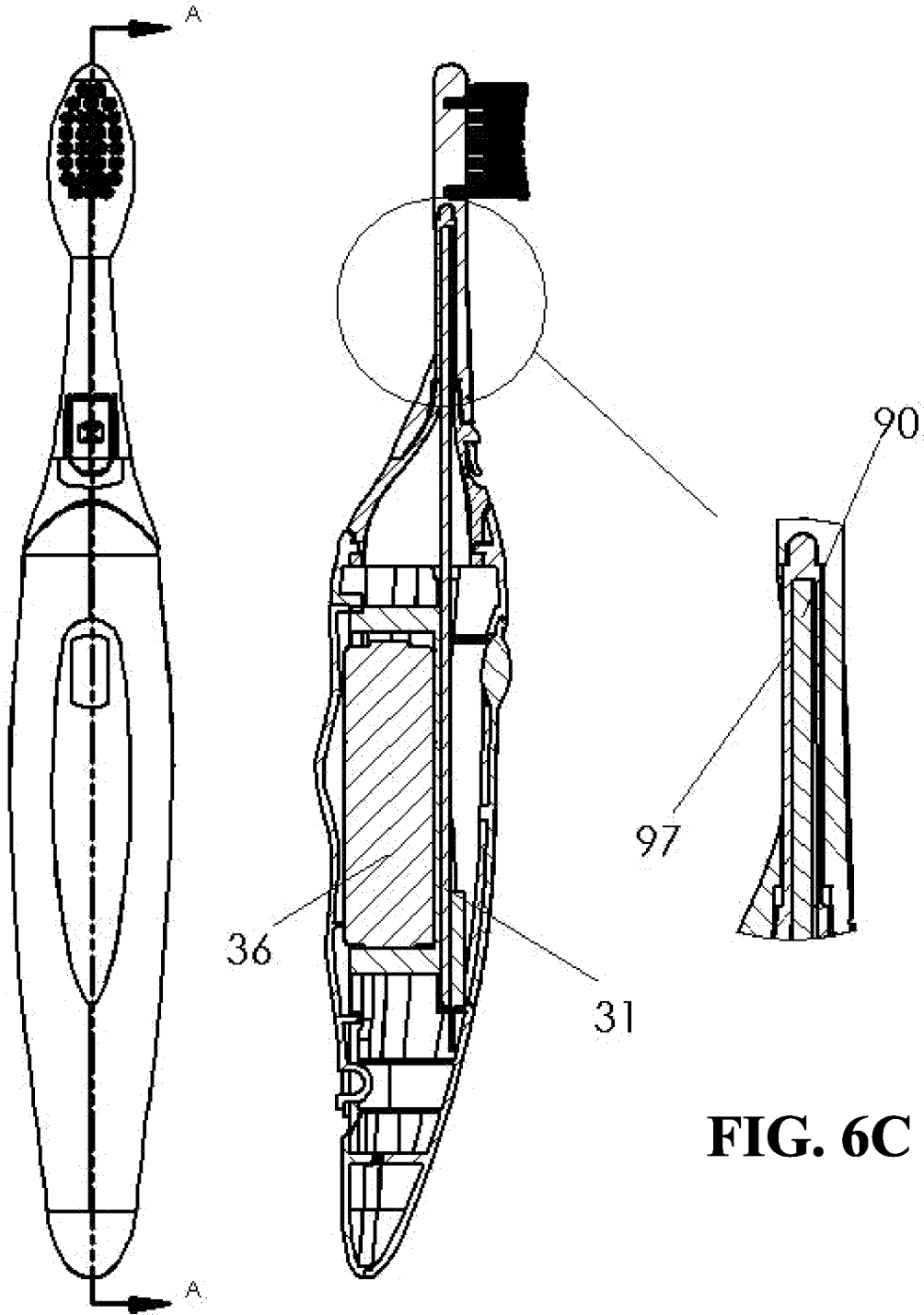

FIG. 6A

FIG. 6B

FIG. 6C

7/15

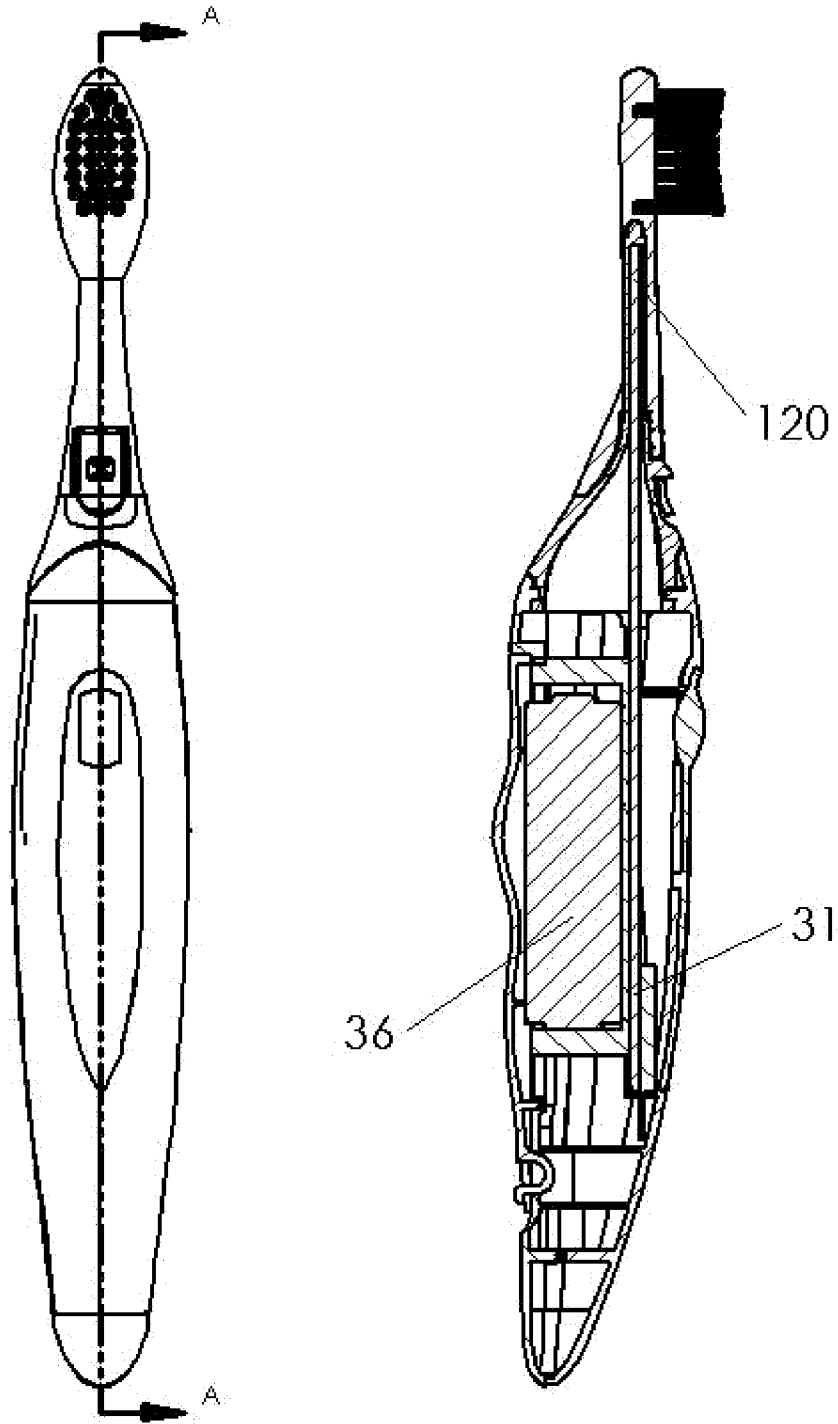

FIG. 7A

FIG. 7B

8/15

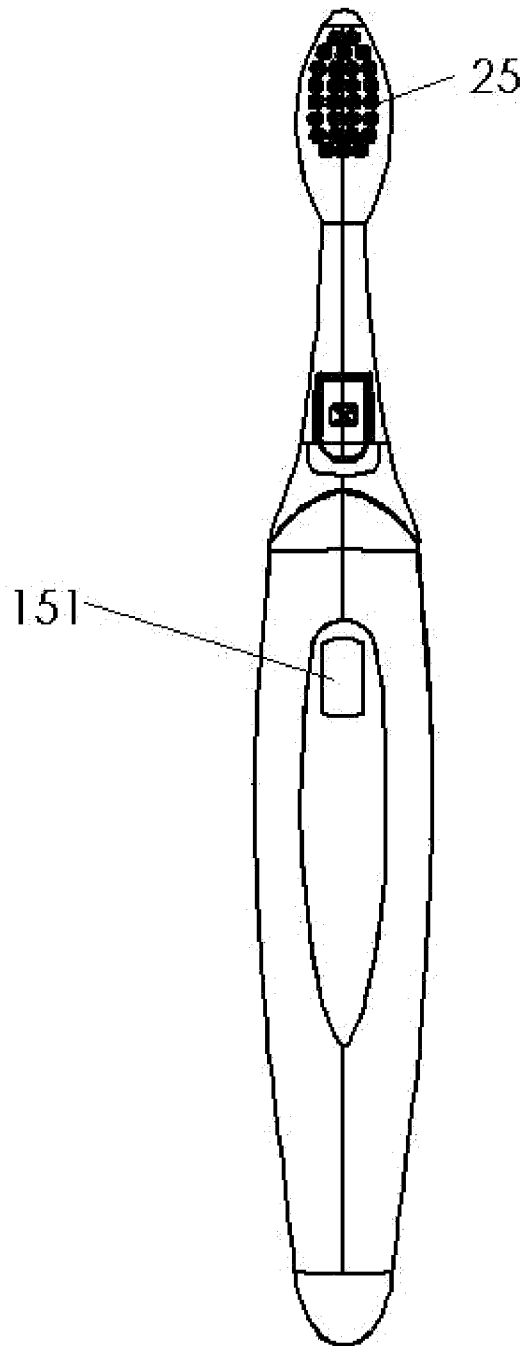

FIG. 8



9/15

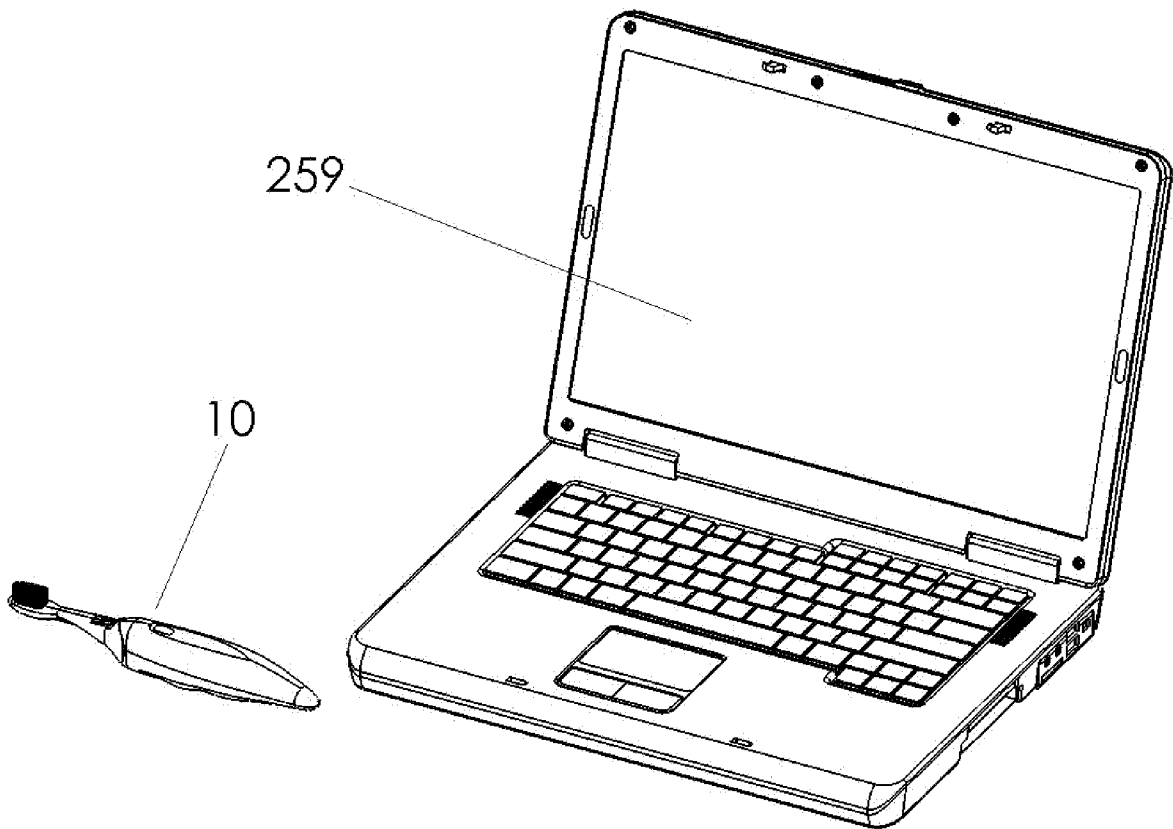

FIG. 9

10/15

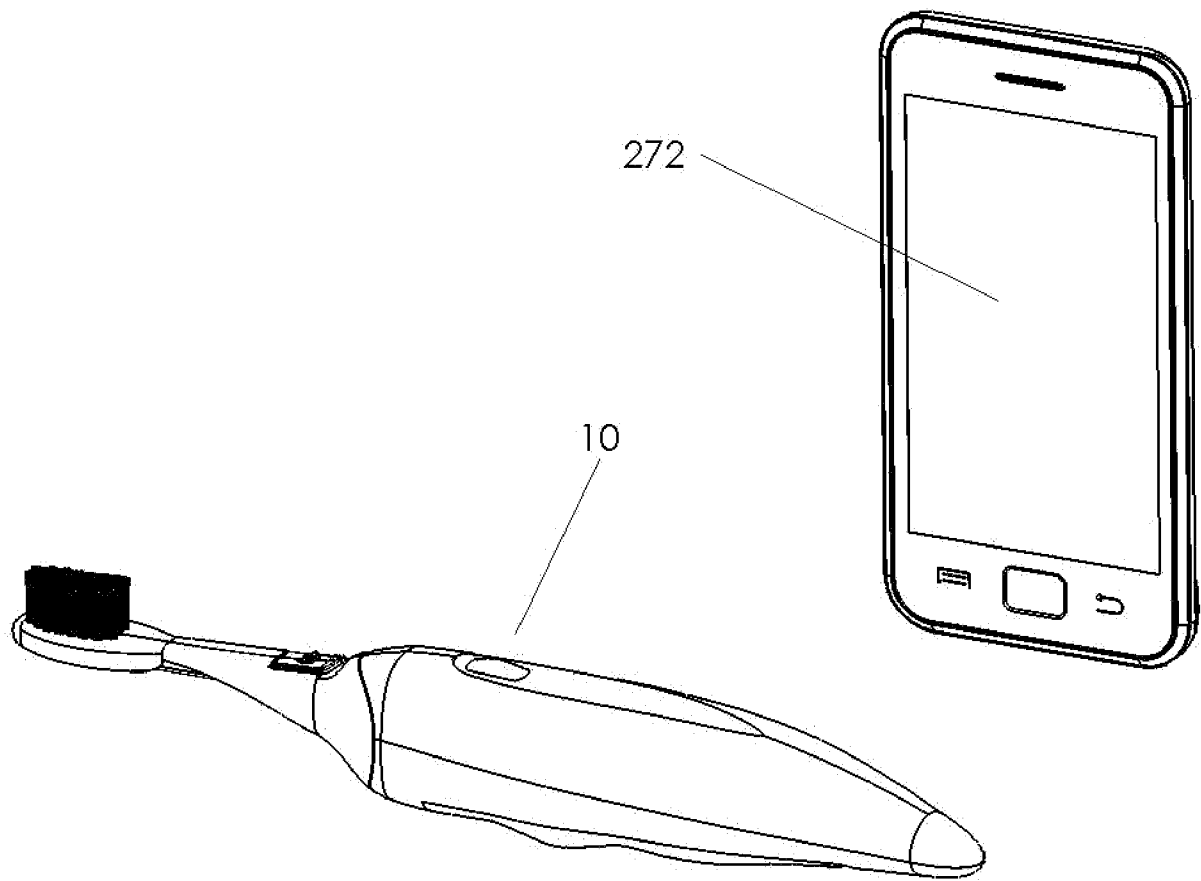

FIG. 10

11/15

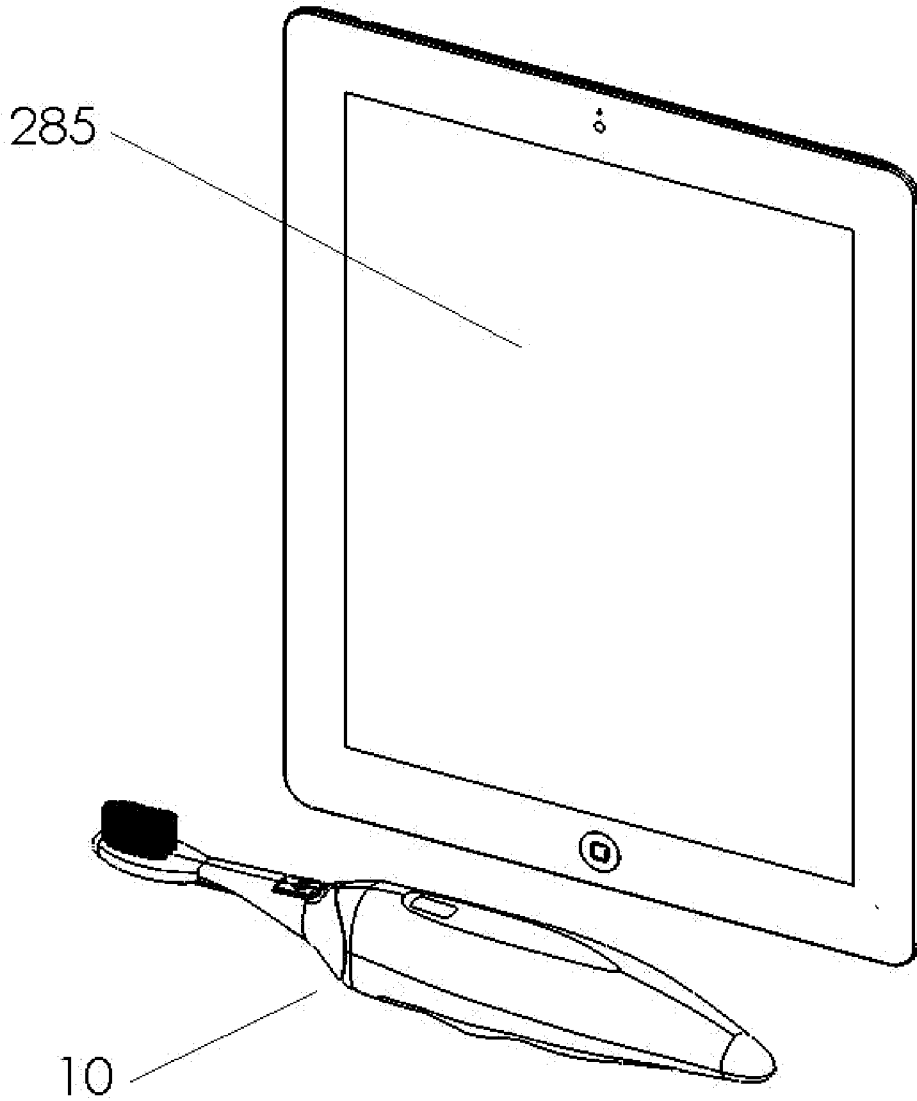

FIG. 11

12/15

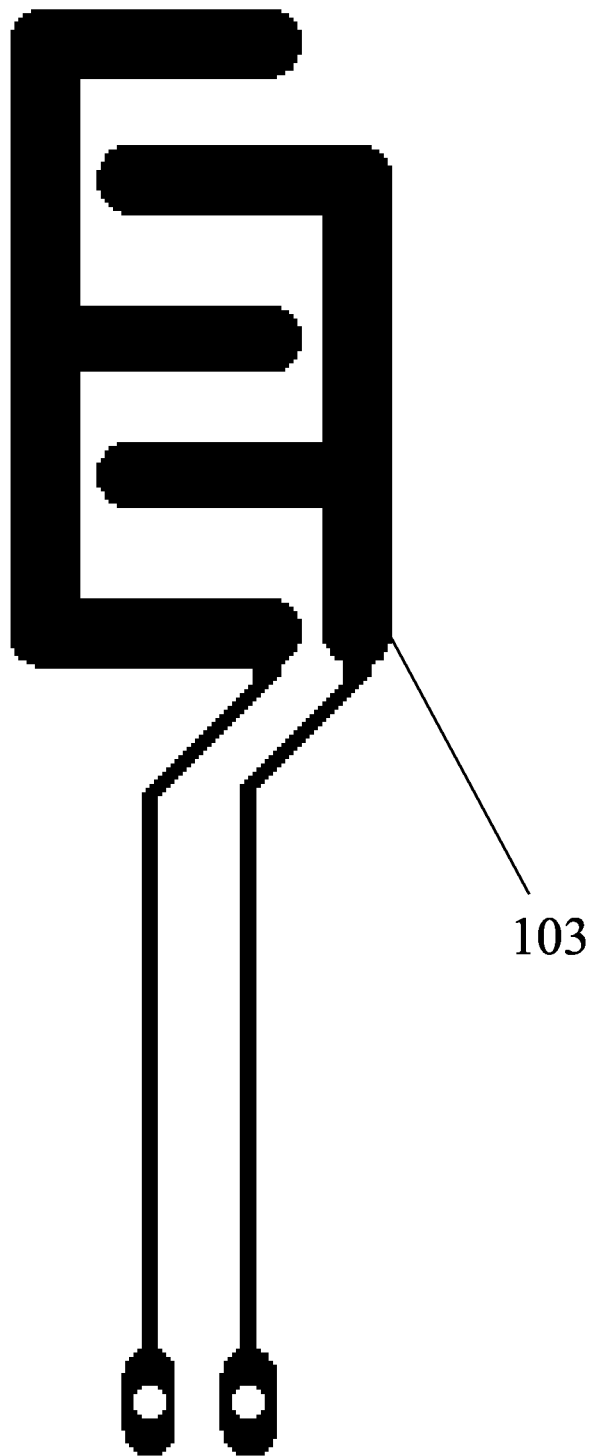

FIG. 12

13/15

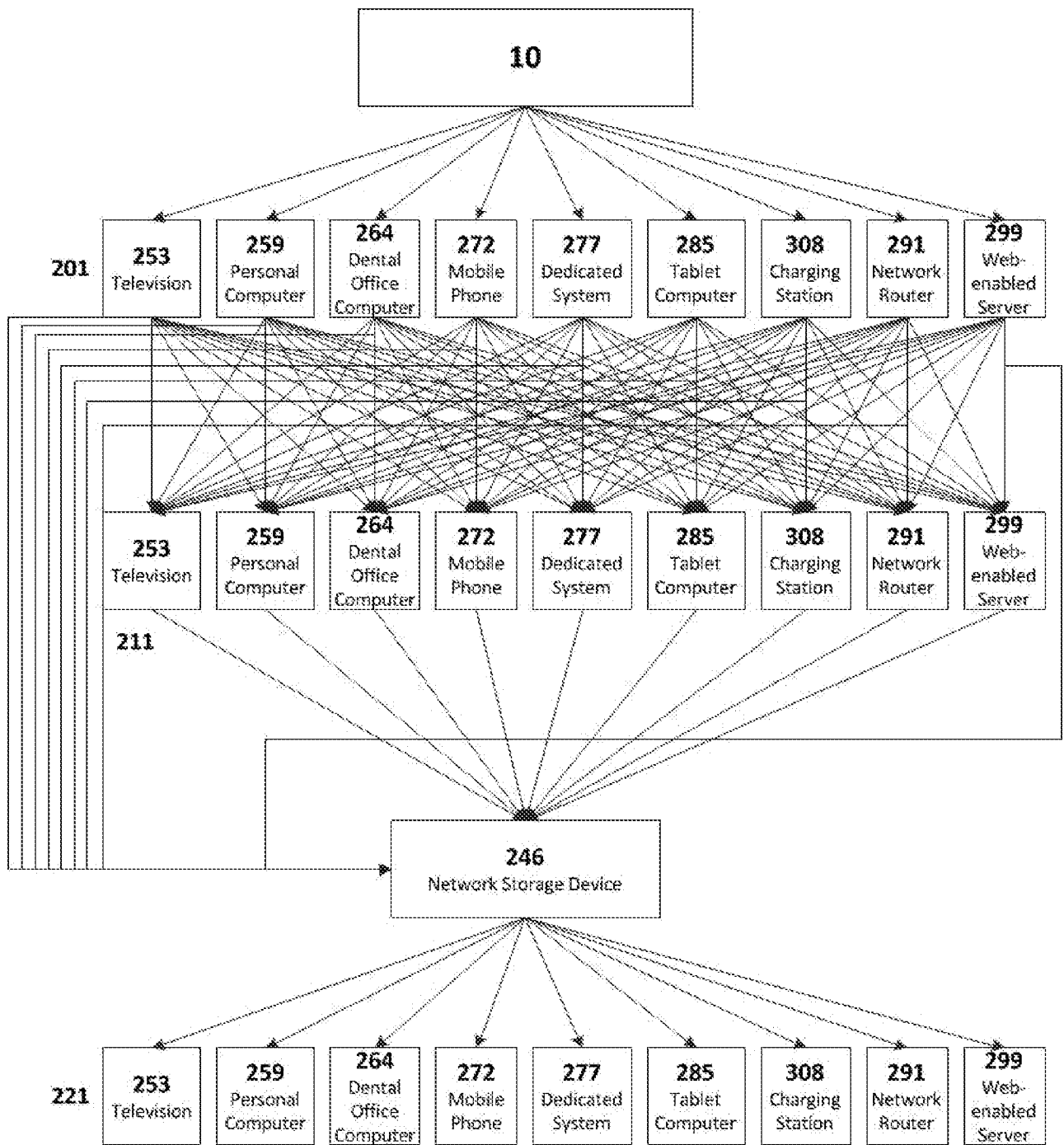

FIG. 13

**14/15****401**

No. of Brushings:	25
Avg. Brushing Duration:	2:00 min.
Last Brush Duration:	1:57 min.
Last Brush Date:	1/1/2011
Last Brush Time:	8:00 am

Lifespan Remaining:	75 %
---------------------	------

Plaque Rating:	8.5
----------------	-----

Alerts:  
Biofilm thickness has increased! Consult  
your dental practiononer.

Updates: No new updates.

**FIG. 14**

**15/15**

**427**



**\$49.99**  
**BUY NOW**  
**COMPARE**

**Description:**

**Diagnostic toothbrush with ultrasonic sensor for the measurement and tracking of biofilm thickness.**

**FIG. 15**

## INTERNATIONAL SEARCH REPORT

International application No.

PCT/US2012/059986

<b>A. CLASSIFICATION OF SUBJECT MATTER</b> IPC(8) - A61B 5/1455 (2012.01) USPC - 600/323 According to International Patent Classification (IPC) or to both national classification and IPC		
<b>B. FIELDS SEARCHED</b> Minimum documentation searched (classification system followed by classification symbols) IPC(8) - A61B 5/00, 5/145, 5/1455; A61C 3/00, 17/00, 17/16, 17/22, 19/04 (2012.01) USPC - 15/167.1; 132/308; 433/114, 141, 215, 216; 600/300, 309, 310, 322, 323; 705/2 Documentation searched other than minimum documentation to the extent that such documents are included in the fields searched Electronic data base consulted during the international search (name of data base and, where practicable, search terms used) PatBase		
<b>C. DOCUMENTS CONSIDERED TO BE RELEVANT</b>		
Category*	Citation of document, with indication, where appropriate, of the relevant passages	Relevant to claim No.
X	US 2007/0027386 A1 (SUCH et al) 01 February 2007 (01.02.2007) entire document	1, 2, 4-22, 24, 31, 33-35, 37
-		
Y		3, 23, 25-30, 32, 36, 38-42
Y	WO 2011/077290 A1 (HALL) 30 June 2011 (30.06.2011) entire document	3, 27-30, 38-42
Y	US 2009/0092955 A1 (HWANG) 09 April 2009 (09.04.2009) entire document	23, 25, 26, 30, 32, 36, 38-42
<input type="checkbox"/> Further documents are listed in the continuation of Box C. <input type="checkbox"/>		
* Special categories of cited documents: "A" document defining the general state of the art which is not considered to be of particular relevance "E" earlier application or patent but published on or after the international filing date "L" document which may throw doubts on priority claim(s) or which is cited to establish the publication date of another citation or other special reason (as specified) "O" document referring to an oral disclosure, use, exhibition or other means "P" document published prior to the international filing date but later than the priority date claimed "T" later document published after the international filing date or priority date and not in conflict with the application but cited to understand the principle or theory underlying the invention "X" document of particular relevance; the claimed invention cannot be considered novel or cannot be considered to involve an inventive step when the document is taken alone "Y" document of particular relevance; the claimed invention cannot be considered to involve an inventive step when the document is combined with one or more other such documents, such combination being obvious to a person skilled in the art "&" document member of the same patent family		
Date of the actual completion of the international search 14 December 2012		Date of mailing of the international search report <b>18 JAN 2013</b>
Name and mailing address of the ISA/US Mail Stop PCT, Attn: ISA/US, Commissioner for Patents P.O. Box 1450, Alexandria, Virginia 22313-1450 Facsimile No. 571-273-3201		Authorized officer: Blaine R. Copenheaver PCT Helpdesk: 571-272-4300 PCT OSP: 571-272-7774