



US00D621319S

(12) **United States Design Patent**
Nissl

(10) **Patent No.:** **US D621,319 S**

(45) **Date of Patent:** **** Aug. 10, 2010**

(54) **WHEEL OR WHEEL COVER**

(75) Inventor: **Florian Dieter Nissl, Munich (DE)**

(73) Assignee: **Bayerische Motoren Werke
Aktiengesellschaft, Munich (DE)**

(**) Term: **14 Years**

(21) Appl. No.: **29/354,017**

(22) Filed: **Jan. 19, 2010**

(30) **Foreign Application Priority Data**

Jul. 20, 2009 (DE) 402009003572

(51) **LOC (9) Cl.** **12-16**

(52) **U.S. Cl.** **D12/209**

(58) **Field of Classification Search** D12/204-213;
301/37.101, 64.101, 65, 64.201
See application file for complete search history.

(56) **References Cited**

U.S. PATENT DOCUMENTS

- D421,417 S * 3/2000 Weidhase D12/209
- D466,853 S * 12/2002 Maifrini D12/211
- D474,141 S * 5/2003 Foose D12/211
- D483,714 S 12/2003 Warming
- D490,761 S * 6/2004 Kataoka D12/211
- D500,277 S * 12/2004 Kataoka D12/209
- D515,491 S 2/2006 Elmitt
- D516,487 S 3/2006 Hettler
- D524,711 S * 7/2006 Marji D12/209

- D572,649 S * 7/2008 Laengerer D12/211
- D585,804 S * 2/2009 Pfeiffer D12/209
- D590,314 S 4/2009 Hettler
- D591,661 S 5/2009 Baum
- D597,014 S * 7/2009 Nissl D12/211
- D605,999 S * 12/2009 Stopp D12/211

FOREIGN PATENT DOCUMENTS

- DE 40202745.0 7/2002
- EM 000304274-0004 5/2005
- EM 000304274-0007 5/2005
- EM 000735758-0007 7/2007
- EM 000863055-0001 3/2008

* cited by examiner

Primary Examiner—Stacia Cadmus

(74) *Attorney, Agent, or Firm*—Crowell & Moring LLP

(57) **CLAIM**

The ornamental design for a wheel or wheel cover, as shown and described.

DESCRIPTION

FIG. 1 is a front view of a wheel or wheel cover according to my design; and,

FIG. 2 is a perspective view thereof.

The broken line showing of the rear of the rim and the bolt holes and center hole in the central hub area is included for the purpose of illustrating environment and forms no part of the claimed design.

1 Claim, 1 Drawing Sheet

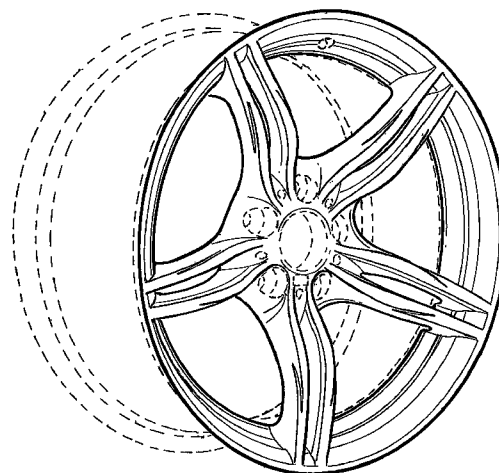
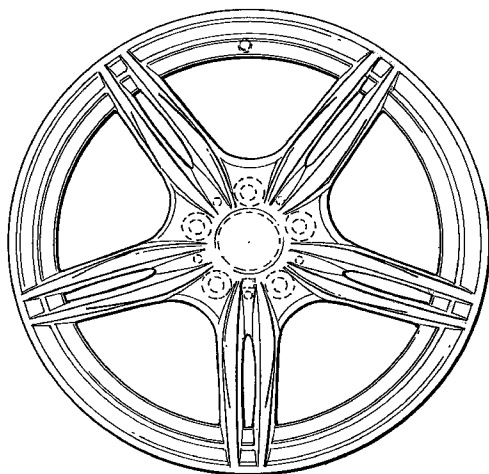

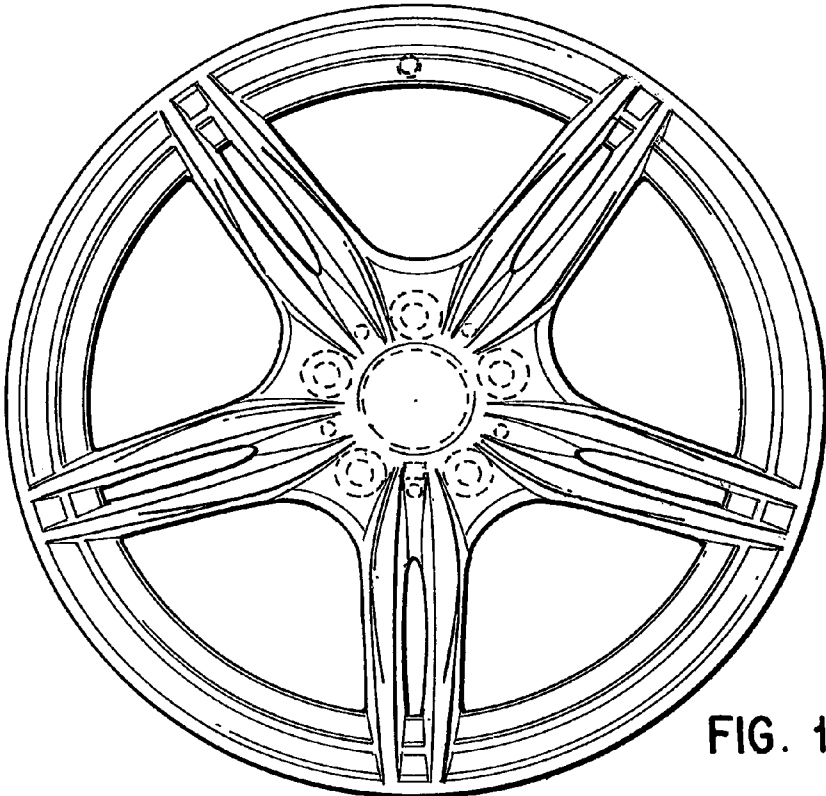

FIG. 1

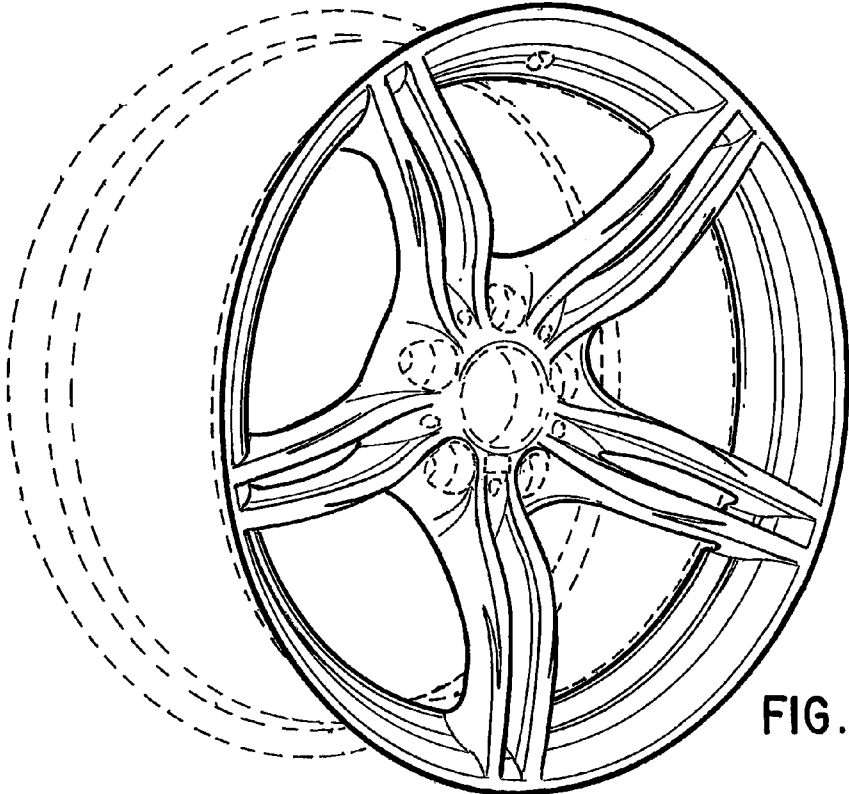

FIG. 2