



INTERNATIONAL APPLICATION PUBLISHED UNDER THE PATENT COOPERATION TREATY (PCT)

<p>(51) International Patent Classification ⁷ : A61F 13/00, 13/10</p>	<p>A1</p>	<p>(11) International Publication Number: WO 00/64394 (43) International Publication Date: 2 November 2000 (02.11.00)</p>
<p>(21) International Application Number: PCT/GB00/01566 (22) International Filing Date: 20 April 2000 (20.04.00) (30) Priority Data: 9909301.5 22 April 1999 (22.04.99) GB (71) Applicant (for all designated States except US): KCI MEDICAL LIMITED [GB/GB]; Two Rivers, Station Lane, Witney, Oxfordshire OX8 6BH (GB). (72) Inventors; and (75) Inventors/Applicants (for US only): HEATON, Keith, Patrick [GB/GB]; 33 Hermitage Road, Poole, Dorset BH13 0QG (GB). HUNT, Kenneth, William [GB/GB]; 18 Egdon Drive, Merley, Wimborne, Dorset BH21 1TY (GB). (74) Agent: WOODCRAFT, David, Charles; Brookes & Martin, High Holborn House, 52/54 High Holborn, London WC1V 6SE (GB).</p>		<p>(81) Designated States: AE, AL, AM, AT, AU, AZ, BA, BB, BG, BR, BY, CA, CH, CN, CR, CU, CZ, DE, DK, DM, EE, ES, FI, GB, GD, GE, GH, GM, HR, HU, ID, IL, IN, IS, JP, KE, KG, KP, KR, KZ, LC, LK, LR, LS, LT, LU, LV, MA, MD, MG, MK, MN, MW, MX, NO, NZ, PL, PT, RO, RU, SD, SE, SG, SI, SK, SL, TJ, TM, TR, TT, TZ, UA, UG, US, UZ, VN, YU, ZA, ZW, ARIPO patent (GH, GM, KE, LS, MW, SD, SL, SZ, TZ, UG, ZW), Eurasian patent (AM, AZ, BY, KG, KZ, MD, RU, TJ, TM), European patent (AT, BE, CH, CY, DE, DK, ES, FI, FR, GB, GR, IE, IT, LU, MC, NL, PT, SE), OAPI patent (BF, BJ, CF, CG, CI, CM, GA, GN, GW, ML, MR, NE, SN, TD, TG).</p> <p>Published <i>With international search report. Before the expiration of the time limit for amending the claims and to be republished in the event of the receipt of amendments.</i></p>
<p>(54) Title: WOUND TREATMENT APPARATUS EMPLOYING REDUCED PRESSURE</p>		
<p>(57) Abstract</p>		
<p>Apparatus is described for stimulating healing of wounds, particularly burns, to the hands or feet. The apparatus comprises an envelope for receiving the affected part of the body. The envelope (12) comprises an air-tight cover which contains a porous pad (22, 24, 26) for covering the wound. Means are provided for connecting the interior of the envelope to a source of suction.</p>		

FOR THE PURPOSES OF INFORMATION ONLY

Codes used to identify States party to the PCT on the front pages of pamphlets publishing international applications under the PCT.

AL	Albania	ES	Spain	LS	Lesotho	SI	Slovenia
AM	Armenia	FI	Finland	LT	Lithuania	SK	Slovakia
AT	Austria	FR	France	LU	Luxembourg	SN	Senegal
AU	Australia	GA	Gabon	LV	Latvia	SZ	Swaziland
AZ	Azerbaijan	GB	United Kingdom	MC	Monaco	TD	Chad
BA	Bosnia and Herzegovina	GE	Georgia	MD	Republic of Moldova	TG	Togo
BB	Barbados	GH	Ghana	MG	Madagascar	TJ	Tajikistan
BE	Belgium	GN	Guinea	MK	The former Yugoslav Republic of Macedonia	TM	Turkmenistan
BF	Burkina Faso	GR	Greece			TR	Turkey
BG	Bulgaria	HU	Hungary	ML	Mali	TT	Trinidad and Tobago
BJ	Benin	IE	Ireland	MN	Mongolia	UA	Ukraine
BR	Brazil	IL	Israel	MR	Mauritania	UG	Uganda
BY	Belarus	IS	Iceland	MW	Malawi	US	United States of America
CA	Canada	IT	Italy	MX	Mexico	UZ	Uzbekistan
CF	Central African Republic	JP	Japan	NE	Niger	VN	Viet Nam
CG	Congo	KE	Kenya	NL	Netherlands	YU	Yugoslavia
CH	Switzerland	KG	Kyrgyzstan	NO	Norway	ZW	Zimbabwe
CI	Côte d'Ivoire	KP	Democratic People's Republic of Korea	NZ	New Zealand		
CM	Cameroon		Republic of Korea	PL	Poland		
CN	China	KR	Republic of Korea	PT	Portugal		
CU	Cuba	KZ	Kazakstan	RO	Romania		
CZ	Czech Republic	LC	Saint Lucia	RU	Russian Federation		
DE	Germany	LI	Liechtenstein	SD	Sudan		
DK	Denmark	LK	Sri Lanka	SE	Sweden		
EE	Estonia	LR	Liberia	SG	Singapore		

WOUND TREATMENT APPARATUS EMPLOYING REDUCED PRESSURE

The present invention relates to an apparatus for the healing of wounds and more particularly to preventing progression of partial-thickness burns.

Where a person suffers a burn, the dermal and epidermal layers in the region of the wound are damaged. Closure of the resulting wound is important to prevent loss of body fluids and invasion by micro-organisms. In the case of a partial-thickness burn, epithelial and subcutaneous tissue adjacent to the wound will migrate outwards and eventually grow new tissue over the wound. A wide array of wound coverings have been developed to expedite wound closure and allow the natural processes of repairing the damaged tissue to proceed.

The prognosis of a wound caused by a burn depends on the severity of the injury and particularly the depth of the burn. In general, a partial-thickness burn will heal more quickly and with less complications than a deeply penetrating burn. It has been observed that partial-thickness burns often deteriorate and become more serious, deeper burns, if not treated promptly after incurring the burn injury.

The hands more often suffer burn injuries than other parts of the body. Probably, this is due to the natural reaction of attempting to protect the face with the hands and, in many cases, the burn injury is to the backs of the hands. Other parts of the body which more frequently suffer burns may be the arms, feet and legs.

The present invention seeks to provide apparatus for treating injuries to a part of the body, especially injuries caused by burns.

According to one aspect of the invention there is provided apparatus for stimulating healing of wounds which comprises an envelope for receiving an affected part of the body, said envelope including a substantially air-tight cover and a porous pad within the cover, said cover being adapted to contact the wound surface, and connection means for connecting the interior of the envelope to a source of negative pressure.

By substantially "air-tight" cover is meant one which is sufficiently air-tight that by applying suction to the porous pad, a pressure below ambient can be maintained within the envelope. It is not, however, necessary for the material of the envelope to be totally air occlusive.

It has been found that when negative pressure therapy using the apparatus of the invention is applied to a burn within a relatively short time of incurring the injury (e.g. within about 12 hours), not only is the rate of healing improved but progression of a partial-thickness burn to a deeper injury is arrested.

In one embodiment, the apparatus of the invention the envelope comprises a glove, sleeve or sock. For example, the apparatus may include a glove formed from a flexible plastics or rubber foam which is contained within a cover of low air-porosity. Typically, the flexible plastics foam is a polyurethane or polyvinyl alcohol (pva) foam having intercommunicating cells or a combination of such foams, e.g. as a laminate. In such a laminate, the pva layer may be adjacent the wound.

Additional features of the present application will become apparent from the following description and accompanying drawings, in which:-

Figure 1 is an exploded perspective view of the porous pad;

Figure 2 is a perspective view when the porous pad is assembled together;

Figure 3 is a perspective view of the porous pad within its cover;

Figures 4a to 4d show various views of a connector for pneumatically connecting the porous pad to a source of negative pressure; and

Figure 5 is a plan view of a modified cover.

The embodiment shown in the accompanying drawings is designed for use in treating burns to the hand.

It will be appreciated that various appropriate modifications are possible for treating burns to other parts of the body, such as feet within the scope of the invention.

Figures 1, 2 and 3 show apparatus (10) for treating wounds to the hands comprising a porous pad having a lower base (22), a middle section (24) and an upper section (26) incorporated within a cover (12) of low air porosity. The porous pad is in the form of a glove or mitten and may be constructed by fixing the upper section (26) to the base (22) while retaining the middle section (24) within the cavity so formed. Typically, the porous pad is a reticulated plastics foam, and may be formed by gluing or welding the separate sections together. When placed inside the pad, the hand is held in place with fingers spread by finger-separators (25) and V-cut type grooves (14). As shown in Figures 2 and 3, the foam may be shaped to provide for a separate supporting compartment (27) for the thumb to aid the attainment of the optimum positions of the fingers and thumb for healing. However, this is not

essential. The pad is preferably made from a reticulated foam such as polyurethane as described in PCT application WO 96/05873, polyvinylalcohol foam or a combination thereof.

Figure 3 shows the assembled pad after insertion into a cover (12). Cover (12) is an envelope formed from air-impermeable sheet material, e.g. polyurethane or polyolefin film, and is sized to encompass the glove-shaped porous pad. One end of the cover (12) has a large opening which is closable by an easily re-sealable means (4) such as a zip-type seal used on food bags. The other end (8) includes a substantially impermeable pressure-sensitive acrylic resin adhesive (9), the underside of which is secured as a tight seal to the patient's skin. The open end (8) may be coated on its inner surface with a pressure-sensitive acrylic resin adhesive (9) in order to seal the cover to the patient's skin, e.g. at the wrist or lower arm. Alternatively, the end (8) may be sealed to the patient's wrist with a separate piece of adhesive tape, such as a polyurethane film coated with a pressure-sensitive adhesive. The open end (8) is open and is tapered as shown. By providing a taper, the open end can be cut to a size such that the opening will fit snugly around the patient's wrist. Attached to the cover (12) in the region of a central part of the porous pad is a connector (100). Connector (100) may be attached to the cover by adhesive.

Figure 5 is a plan view of a cover similar to cover (12) shown in Figure 3. The same reference numerals are used to indicate corresponding parts. The cover shown in Figure 5 differs from that shown in Figure 3 in that the end (8) for attachment at the patient's wrist has a somewhat larger taper and is designed so that

the end can be trimmed to suit the patient. The connector (100) has a generally circular flange (101) whose underside face (i.e. the face which in use contacts the foam page 20) is formed with small projecting buttons. The construction of this aspect of the connector is as described in GB Patent Application No. 2,333,965. Instead of using a zip lock seal, a seal of the "Velcro" type can be used. In this embodiment, a zip lock seal (4) is formed from polyethylene and this is joined to the rest of the cover, which is formed from polyurethane, by adhesive tape.

Figures 4a to 4d show various views of the connector (100) and it will be seen that it comprises a moulded plastics flange portion (101) and suction port having a centrally positioned spout (102) and aperture (106). The connector (100) is firmly attached to the cover by an adhesive. The spout extends through a hole cut in the cover and the upper surface of the flange 101 is bonded with adhesive to the cover (12). The spout (102) is sized to accept as a closely sliding fit, the end of a single or multi-lumen tube (30) which emerges from beneath the wound cover (12). Tube (30) may be constructed as described in co-pending patent application WO 97/18007. Where a multi-lumen tube is used, one lumen can be used for measuring the pressure at the burn site. It is also within the scope of this invention to irrigate the burn or other wound through one of the lumens or via a separate connector to the foam pad. The connector or connectors can be used to introduce drugs, e.g. antibiotics, to the wound site. The cover drape (12) is preferably made from a flexible film of low air permeability such as polyurethane and may include a protective layer of polyethylene. Suitable materials are described in GB patent application No. 2,333,965.

In use, the hand of a patient having a burn injury is introduced into the outer cover (12) via the open end (8). Re-sealable opening (4) may then be opened and folded back to expose the injured hand. The hand is then introduced into the porous pad which may be pre-assembled or assembled in situ around the injured hand. In the latter case, it may be convenient to fix the upper section (26) to the lower section (24) by suturing or stapling, rather than gluing or welding the foam. With the foam pad in place encompassing the injured hand, the cover (12) is drawn back over the porous pad and the opening (4) re-sealed. Spout (102) is then connected by a tube to a suction pump, e.g. using the technique described in WO 97/18007. Pulsed, intermittent or continuous negative pressure may be applied to the patient's hand in accordance with a programme which may be controlled automatically by a control device associated with the pump as described in our above patent application. Negative pressure therapy using the apparatus of the invention has been found to stimulate healing of burns and to reduce the progression of cell death beneath a burn injury. Also, by improving blood flow to the wound area, infection is controlled and granulation of the wound is stimulated.

One additional beneficial effect of therapy using the apparatus of this invention is that during therapy, the hand is held firmly in a half-closed position, which is the optimum position for promotion of healing. This can be further encouraged by the introduction of a rigid or semi-rigid splint, e.g. of plastics, which is formed or moulded into the desired shape, the collapsed dressing being strapped to the splint during or

after application of the suction, so that the desired healing position can be maintained after release of the suction.

The suction pump is preferably controlled by control means including a pressure transducer for monitoring pressure at the wound site as described in our above PCT application. A timer device may also be associated with the pump to provide on/off operation if necessary at selected intervals. The apparatus may also include a canister located between the porous pad and the pump to collect wound exudate. Typically, the pump is a diaphragm pump but other types of pumps and equivalent components, such vacuum bottles, may be substituted. The apparatus may also be used with a wall suction source as described in GB patent application No. 2,342,584.

The terms and expressions which have been employed are used as terms of description and not of limitation. Although the present invention relates mainly to partial-thickness burns, it is understood that the present invention maybe used with open wounds as well as a possible treatment of pressure sores.

CLAIMS:-

1. Apparatus for stimulating healing of wounds which comprises an envelope for receiving an affected part of the body, said envelope including a substantially air-tight cover and a porous pad within the cover, said pad being adapted to contact the wound surface, and connection means for connecting the interior of the envelope to a source of negative pressure.
2. Apparatus as claimed in claim 1 wherein the envelope comprises a glove, sock or sleeve.
3. Apparatus as claimed in claim 2 which is intended for treating wounds to the hand and comprises a glove formed from a flexible plastics or rubber foam and an external cover of air-impermeable sheet material.
4. Apparatus as claimed in claim 3 wherein the connection means comprises a tube which communicates with the foam within the cover.
5. Apparatus as claimed in any one of the preceding claims wherein the cover has a re-sealable opening which permits the wound to be inspected at intervals.
6. Apparatus as claimed in any one of the preceding claims wherein the source of negative pressure is a suction pump.
7. Apparatus as claimed in any one of the preceding claims which includes a canister for collecting wound exudate.

1/4

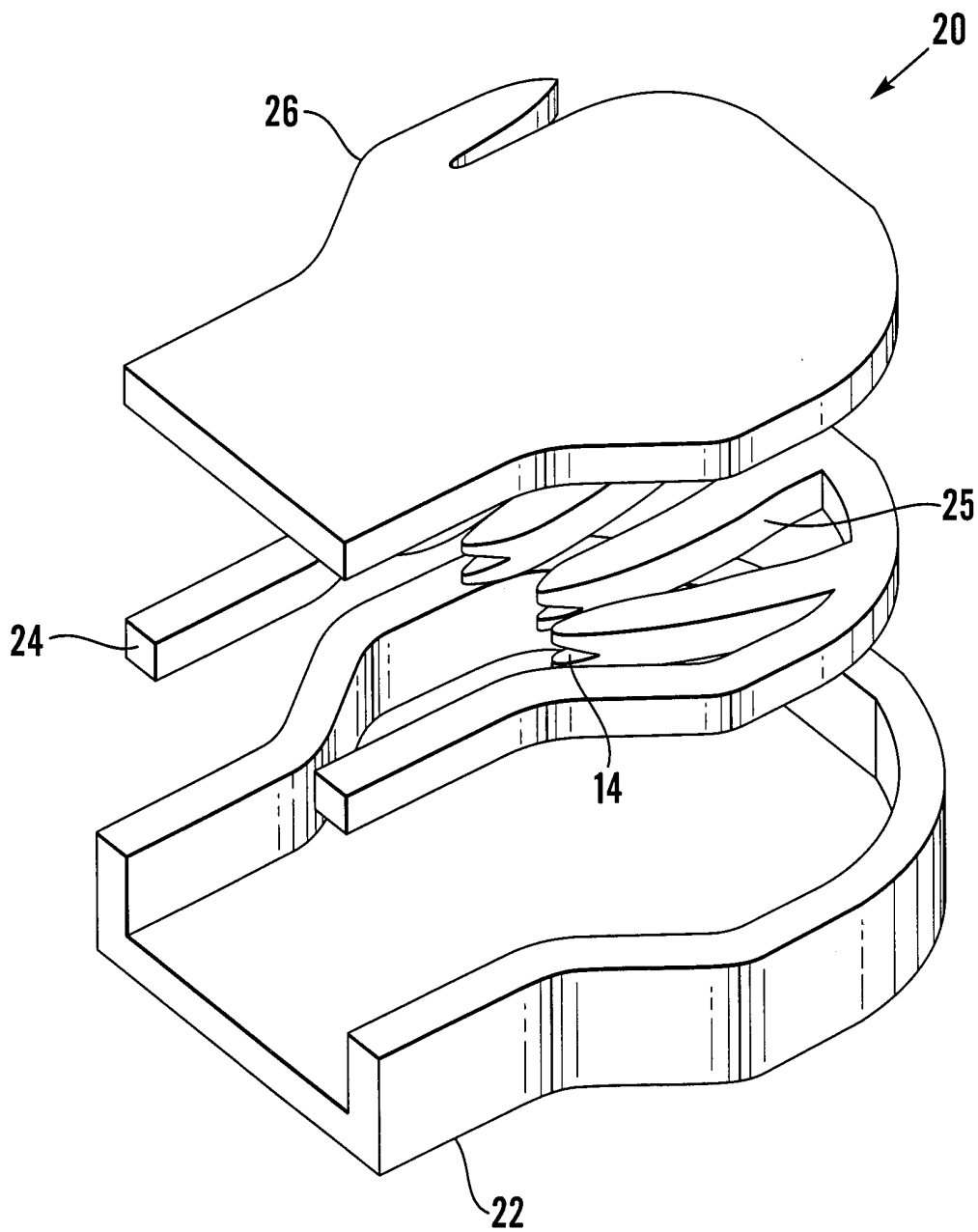

Fig. 1

2/4

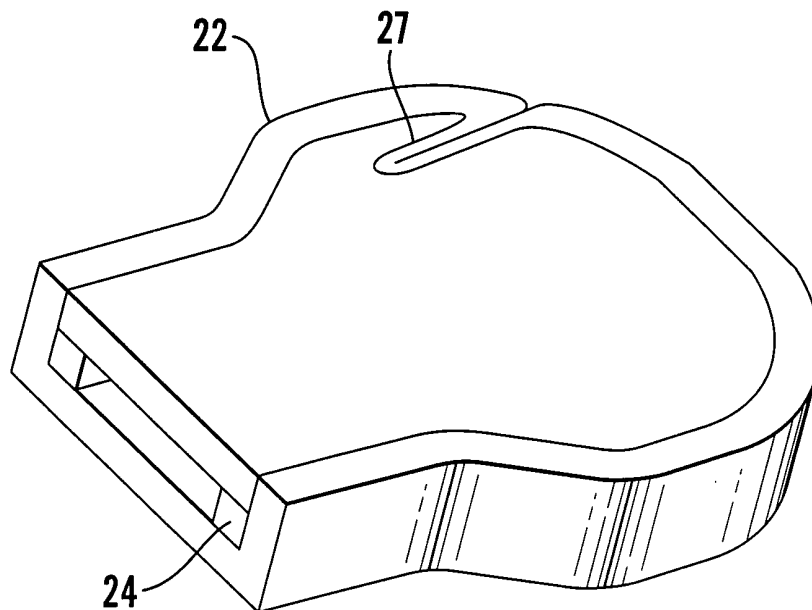

Fig. 2

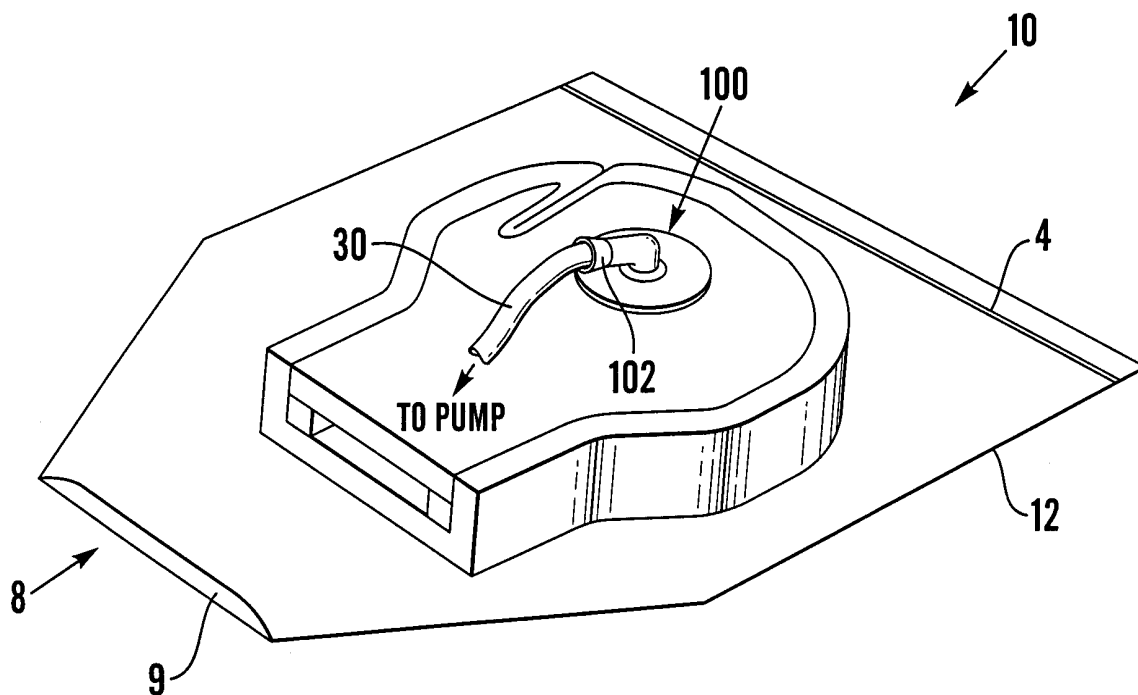

Fig. 3

3/4

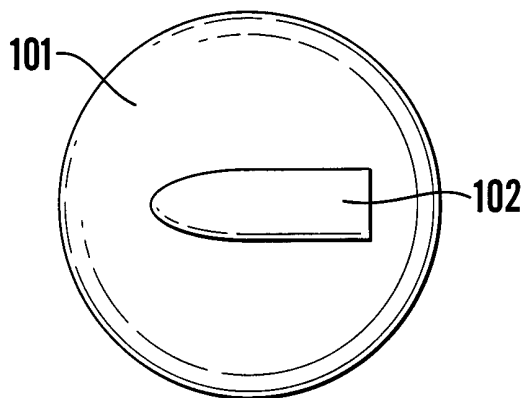

Fig. 4A

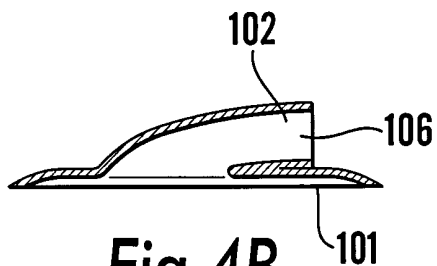

Fig. 4B

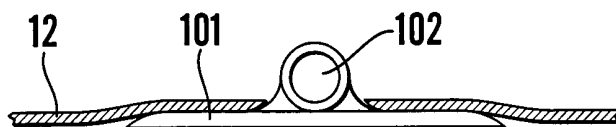

Fig. 4C

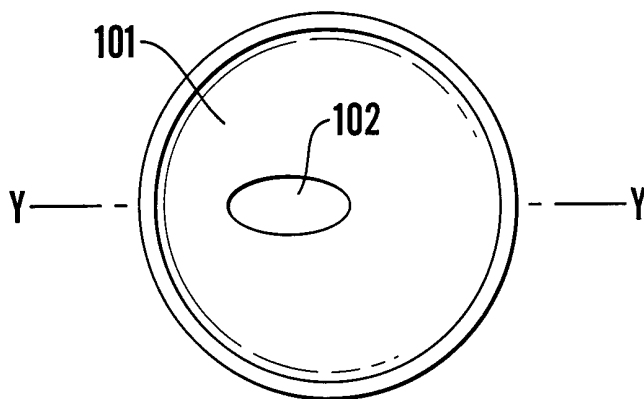

Fig. 4D

4/4

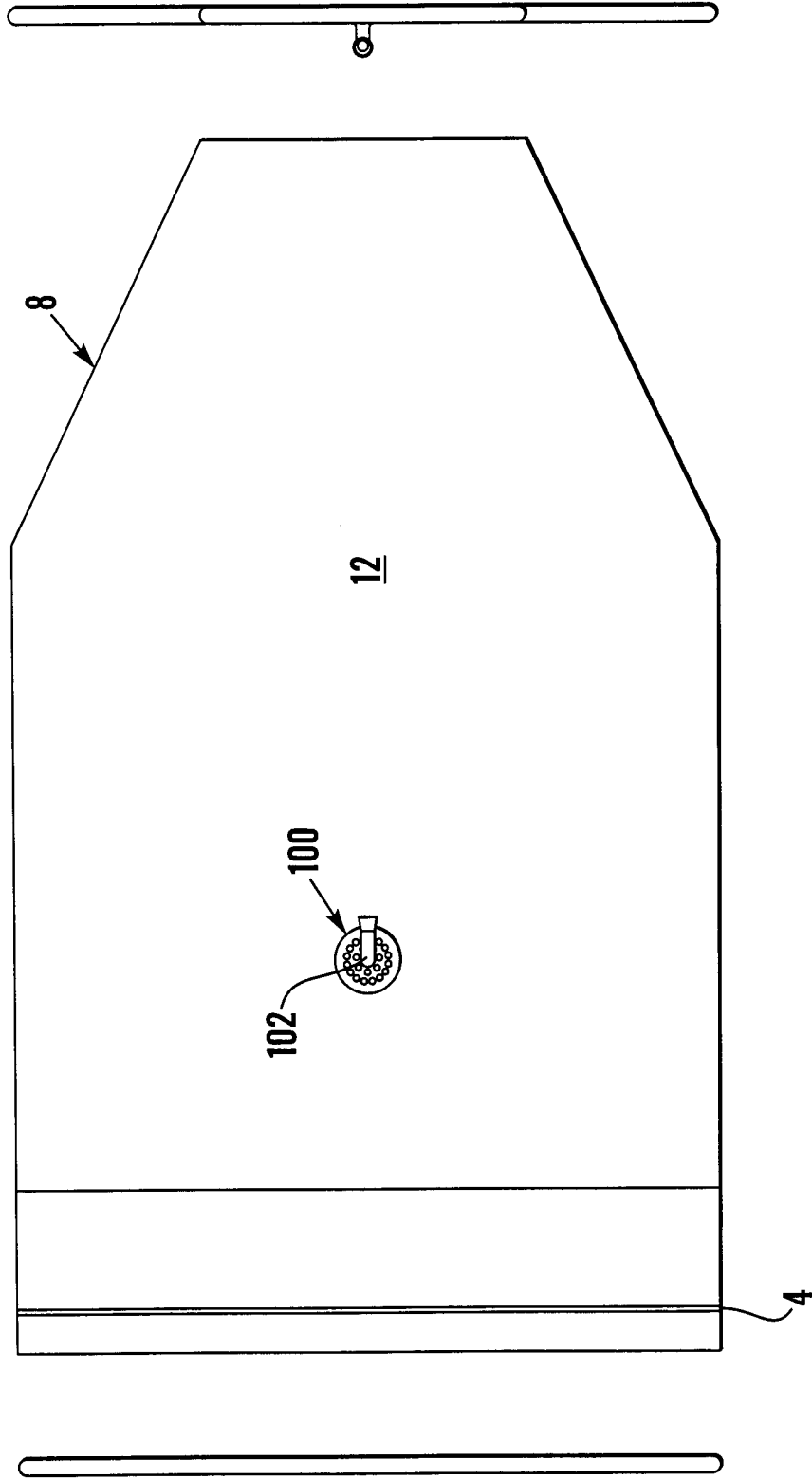

Fig.5

INTERNATIONAL SEARCH REPORT

International Application No

PCT/GB 00/01566

A. CLASSIFICATION OF SUBJECT MATTER
 IPC 7 A61F13/00 A61F13/10

According to International Patent Classification (IPC) or to both national classification and IPC

B. FIELDS SEARCHED

Minimum documentation searched (classification system followed by classification symbols)
 IPC 7 A61F

Documentation searched other than minimum documentation to the extent that such documents are included in the fields searched

Electronic data base consulted during the international search (name of data base and, where practical, search terms used)

EPO-Internal, WPI Data, PAJ

C. DOCUMENTS CONSIDERED TO BE RELEVANT

Category °	Citation of document, with indication, where appropriate, of the relevant passages	Relevant to claim No.
X	US 4 969 880 A (ZAMIEROWSKI DAVID S) 13 November 1990 (1990-11-13) column 7, line 7 - line 16; figure 8 ---	1,4-7
A	DE 10 93 949 B (DIPL.-ING. ALFRED MAIER) 1 December 1960 (1960-12-01) column 2, line 34 - line 51; figure 1 ---	1-7
A	US 5 527 293 A (ZAMIEROWSKI DAVID S) 18 June 1996 (1996-06-18) claim 1; figure 24 -----	1-7

Further documents are listed in the continuation of box C.

Patent family members are listed in annex.

° Special categories of cited documents :

- "A" document defining the general state of the art which is not considered to be of particular relevance
- "E" earlier document but published on or after the international filing date
- "L" document which may throw doubts on priority claim(s) or which is cited to establish the publication date of another citation or other special reason (as specified)
- "O" document referring to an oral disclosure, use, exhibition or other means
- "P" document published prior to the international filing date but later than the priority date claimed

- "T" later document published after the international filing date or priority date and not in conflict with the application but cited to understand the principle or theory underlying the invention
- "X" document of particular relevance; the claimed invention cannot be considered novel or cannot be considered to involve an inventive step when the document is taken alone
- "Y" document of particular relevance; the claimed invention cannot be considered to involve an inventive step when the document is combined with one or more other such documents, such combination being obvious to a person skilled in the art.
- "&" document member of the same patent family

Date of the actual completion of the international search

13 September 2000

Date of mailing of the international search report

25/09/2000

Name and mailing address of the ISA

European Patent Office, P.B. 5818 Patentlaan 2
 NL - 2280 HV Rijswijk
 Tel. (+31-70) 340-2040, Tx. 31 651 epo nl,
 Fax: (+31-70) 340-3016

Authorized officer

Westermayer, W

INTERNATIONAL SEARCH REPORT

Information on patent family members

International Application No

PCT/GB 00/01566

Patent document cited in search report	Publication date	Patent family member(s)	Publication date
US 4969880 A	13-11-1990	AT 146980 T	15-01-1997
		AU 654468 B	10-11-1994
		AU 5521890 A	05-11-1990
		CA 2049948 A	04-10-1990
		DE 69029578 D	13-02-1997
		DE 69029578 T	05-06-1997
		EP 0465601 A	15-01-1992
		JP 4506011 T	22-10-1992
		WO 9011795 A	18-10-1990
		US 5527293 A	18-06-1996
		US 5100396 A	31-03-1992
		US 5261893 A	16-11-1993

DE 1093949 B		NONE	

US 5527293 A	18-06-1996	US 5261893 A	16-11-1993
		US 5100396 A	31-03-1992
		US 4969880 A	13-11-1990
		AU 2029592 A	30-12-1992
		CA 2103033 A	15-11-1992
		WO 9220299 A	26-11-1992
		AT 146980 T	15-01-1997
		AU 654468 B	10-11-1994
		AU 5521890 A	05-11-1990
		CA 2049948 A	04-10-1990
		DE 69029578 D	13-02-1997
		DE 69029578 T	05-06-1997
		EP 0465601 A	15-01-1992
		JP 4506011 T	22-10-1992
		WO 9011795 A	18-10-1990
