

(12) INTERNATIONAL APPLICATION PUBLISHED UNDER THE PATENT COOPERATION TREATY (PCT)

(19) World Intellectual Property Organization  
International Bureau



(43) International Publication Date  
1 May 2003 (01.05.2003)

PCT

(10) International Publication Number  
**WO 03/036460 A1**

(51) International Patent Classification<sup>7</sup>: **G06F 3/14**

(21) International Application Number: PCT/KR02/01977

(22) International Filing Date: 22 October 2002 (22.10.2002)

(25) Filing Language: English

(26) Publication Language: English

(30) Priority Data:  
2001/65388 23 October 2001 (23.10.2001) KR  
2002/14586 18 March 2002 (18.03.2002) KR  
2002/30609 31 May 2002 (31.05.2002) KR

(71) Applicant: **SAMSUNG ELECTRONICS CO., LTD.**  
[KR/KR]; 416 Maetan-dong, Paldal-gu, Suwon-city,  
Kyungki-do 442-373 (KR).

(72) Inventors: **CHUNG, Hyun-Kwon**; 104-906 Dongbo  
Apt., 45 Tanbeol-ri, Gwangju-eub, Gwangju-gun,

Gyeonggi-do 464-800 (KR). **JUNG, Kil-Soo**;  
107-707 Hanshin Apt., 485 Byungjeom-ri, Taean-eub,  
Hwaseong-gun, Gyeonggi-do 445-970 (KR). **HEO,  
Jung-Kwon**; 203-504 Jugong 2-danji Apt., 18-1 Banpo  
2-dong, Seocho-gu, Seoul 137-042 (KR). **PARK,  
Sung-Wook**; 2-1207 Century Officetel Apt., 1595-2  
Seocho 3-dong, Seocho-gu, Seoul 137-073 (KR). **KO,  
Jung-Wan**; 103-201 Byucksan Apt., 488 Mangpo-dong,  
Paldal-gu, Suwon-si, Gyeonggi-do 442-400 (KR).  
**MOON, Seong-Jin**; 436-502 Cheongmyung, Maeul  
4-danji Apt., 1046-1, Youngtong-dong, Paldal-gu, Su-  
won-si, Gyeonggi-do 442-400 (KR).

(74) Agent: **LEE, Young-Pil**; The Cheonghwa Building,  
1571-18 Seocho-dong, Seocho-gu, Seoul 137-874 (KR).

(81) Designated States (*national*): AE, AG, AL, AM, AT, AU,  
AZ, BA, BB, BG, BR, BY, BZ, CA, CH, CN, CO, CR, CU,  
CZ, DE, DK, DM, DZ, EC, EE, ES, FI, GB, GD, GE, GH,  
GM, HR, HU, ID, IL, IN, IS, JP, KE, KG, KP, KZ, LC, LK,  
LR, LS, LT, LU, LV, MA, MD, MG, MK, MN, MW, MX,

[Continued on next page]

(54) Title: INFORMATION STORAGE MEDIUM INCLUDING MARKUP DOCUMENT AND AV DATA, RECORDING METHOD, REPRODUCING METHOD, AND REPRODUCING APPARATUS THEREFOR

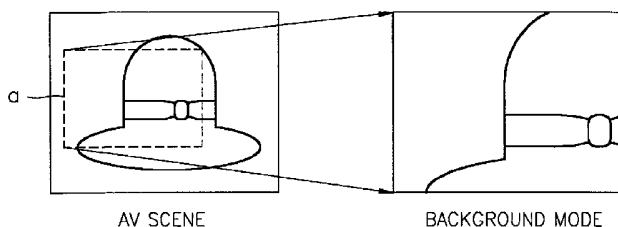

AV SCENE

BACKGROUND MODE

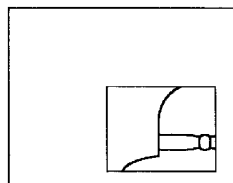

PIP MODE

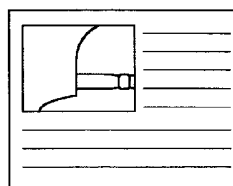

EMBEDDED MODE

(57) Abstract: An information storage medium including a markup document and AV data, a recording method, a reproducing method, and a reproducing apparatus therefor are provided. The information storage medium includes AV data including audio data and video data, a markup document, and scene synthesis information which describes one of at least two display modes for displaying a markup document scene obtained from the markup document and an AV scene obtained from the AV data together.



WO 03/036460 A1



MZ, NO, NZ, OM, PH, PL, PT, RO, RU, SD, SE, SG, SI, SK, SL, TJ, TM, TN, TR, TT, TZ, UA, UG, UZ, VC, VN, YU, ZA, ZM, ZW.

TR), OAPI patent (BF, BJ, CF, CG, CI, CM, GA, GN, GQ, GW, ML, MR, NE, SN, TD, TG).

**(84) Designated States (regional):** ARIPO patent (GH, GM, KE, LS, MW, MZ, SD, SL, SZ, TZ, UG, ZM, ZW), Eurasian patent (AM, AZ, BY, KG, KZ, MD, RU, TJ, TM), European patent (AT, BE, BG, CH, CY, CZ, DE, DK, EE, ES, FI, FR, GB, GR, IE, IT, LU, MC, NL, PT, SE, SK,

**Published:**

— with international search report

*For two-letter codes and other abbreviations, refer to the "Guidance Notes on Codes and Abbreviations" appearing at the beginning of each regular issue of the PCT Gazette.*

**INFORMATION STORAGE MEDIUM INCLUDING MARKUP  
DOCUMENT AND AV DATA, RECORDING METHOD, REPRODUCING  
METHOD, AND REPRODUCING APPARATUS THEREFOR**

5 Technical Field

The present invention relates to a method for displaying AV data together with a markup document, and more particularly, to an information storage medium including a markup document and AV data so that the markup document and the AV data can be reproduced and displayed together in various ways in an interactive mode, a recording method, a reproducing method, and a reproducing apparatus therefor.

Background Art

Digital video discs (DVDs), (hereinafter, referred to as "interactive DVDs") on which a markup document is recorded together with AV data, have been initially developed for movie applications and later started to be widely used in a computer industry. AV data recorded on interactive DVDs can be reproduced in two ways: a video mode displayed identically in a conventional DVD, and an interactive mode in which reproduced AV data is displayed in a display window defined by a markup document. If the interactive mode is selected by a user, a viewer installed in a DVD reproducing apparatus displays a markup document recorded on an interactive DVD. AV data selected by the user is displayed in the display window of the markup document. For example, when the AV data is a movie, the movie is run in the display window of the markup document, and various additional information including scenario, history, and actors' pictures related to the movie are displayed in the remaining part of a screen excluding the display window of the markup document. The additional information includes image files or text files.

However, until now, in the interactive mode, the AV data is based on a simple displaying method in which the AV data is displayed through the display window defined according to grammar of markup languages.

## 5 Disclosure of the Invention

To solve the above and other problems, it is an aspect of the present invention to provide an information storage medium including AV data and a markup document so that the AV data and the markup document can be reproduced and displayed in various ways in an  
10 interactive mode, a recording method, a reproducing method, and a reproducing apparatus therefor.

It is another aspect of the present invention to provide an information storage medium including AV data and a markup document so that the AV data and the markup document can be displayed in  
15 various ways in an interactive mode in response to resolution and aspect ratio (screen ratio), which are set by a user or set in a reproducing apparatus, a recording method, a reproducing method, and a reproducing apparatus therefor.

It is still another aspect of the present invention to provide an  
20 information storage medium including interactive contents manufactured at a fixed aspect ratio so that the interactive contents can be effectively displayed on a display having various aspect ratios, a recording method, a reproducing method, and a reproducing apparatus therefor.

Accordingly, to achieve the above aspects, according to one  
25 aspect of the present invention, there is provided an information storage medium. The information storage medium includes AV data including audio data and video data, a markup document, and scene synthesis information which describes one of at least two display modes for displaying a markup document scene obtained from the markup  
30 document and an AV scene obtained from the AV data together.

Preferably, the scene synthesis information includes a link tag

recorded in the markup document, and more preferably, the scene synthesis information includes a cascading style sheet (CSS) inserted in the link tag.

The CSS includes at least one of display mode designation  
5 information for designating a display mode of the AV scene, an AV  
trimming area designation information for designating an area to  
increase and reduce a desired portion of the AV scene, background  
color designation information for designating a background color of the  
AV scene, trimming area designation information for designating a  
10 trimming area of a scene in which the AV scene is synthesized with the  
markup document, window designation information for designating a  
window in which a scene where the AV scene is synthesized with the  
markup document is displayed on the screen of a display, screen display  
type information representing an aspect ratio of a scene in which the AV  
15 scene is synthesized with the markup document scene, and window  
designation information of the AV scene for designating an area of a  
window in which a trimmed AV scene is displayed on the screen of the  
display.

Further, the scene synthesis information further includes an object  
20 having property variables for controlling the CSS and a program for  
controlling the CSS on the basis of the object.

To achieve the above aspects, according to another aspect of the  
present invention, there is provided a method for recording AV data  
including audio data and video data on an information storage medium.  
25 The method comprises (a) recording the AV data, (b) recording a markup  
document to be displayed together with the AV data, and (c) recording  
scene synthesis information which describes one of at least two display  
modes for displaying a markup document scene obtained from the  
markup document and an AV scene obtained from the AV data together.

30 In step (a), the AV data is recorded in a video directory, in step (b),  
the markup document is recorded in an interactive directory, and in step

(c), the scene synthesis information is recorded in the interactive directory.

In step (b), contents which should be displayed, are recorded in a maximum area shown regardless of an aspect ratio of the display, that is, a hot area, and unimportant contents are recorded or any contents are not recorded in the other area. When the markup document having a first aspect ratio is displayed on a display having a second aspect ratio having a resolution lower than that of the first aspect ratio, the hot area is selected using the trimming area designation information of the synthesized scene, and the selected hot area is mapped to a designated area on the screen of the display using the window designation information of the synthesized scene.

To achieve the above aspects, according to another aspect of the present invention, there is provided a method for reproducing AV data including audio data and video data recorded on an information storage medium. The method comprises (a) interpreting a markup document to be displayed together with the AV data, (b) interpreting scene synthesis information which describes at least two display modes for displaying a markup document scene obtained by reproducing the markup document and an AV scene obtained by reproducing the AV data together, and (c) displaying the AV scene and the markup document scene in one of the display modes according to the interpreted scene synthesis information.

To achieve the above aspects, according to another aspect of the present invention, there is provided a method for reproducing AV data including audio data and video data having a predetermined aspect ratio recorded on an information storage medium and a markup document having a predetermined aspect ratio and displaying the AV data and the markup document. The method comprises (a) reading scene synthesis information corresponding to a scene mode set in a reproducing apparatus or set by a user, and (b) interpreting the read scene synthesis

information, displaying an AV scene obtained by reproducing the AV data and a markup document scene obtained by reproducing the markup document to be displayed together with the AV data, and changing the output state of the markup document scene in response to scene mode  
5 change.

To achieve the above aspects, according to another aspect of the present invention, there is provided an apparatus for reproducing AV data including audio data and video data recorded on an information storage medium. The apparatus includes a reading unit which reads  
10 the AV data and a markup document to be displayed together with the AV data, a decoder which decodes the AV data read by the reading unit and outputs an AV scene, and a controller which interprets the markup document read by the reading unit, outputs a markup document scene, interprets scene synthesis information which describes at least two  
15 display modes for displaying the markup document scene together the AV scene, and displays the AV scene and the markup document scene in one of the display modes according to the interpreted scene synthesis information.

To achieve the above aspects, according to another aspect of the present invention, there is provided an apparatus for reproducing AV data including audio data and video data recorded on an information storage medium. The apparatus includes a reading unit which reads  
20 the AV data and a markup document to be displayed together with the AV data, a decoder which decodes the AV data read by the reading unit and outputs an AV scene, and a controller which interprets scene synthesis information corresponding to a scene mode set in a reproducing apparatus or set by a user, interprets the markup document to be displayed together with the AV data read by the reading unit using the interpreted scene synthesis information, displays a markup  
25 document scene, and changes the output state of the markup document scene in response to scene mode change.  
30

### Brief Description of the Drawings

The above aspects and advantages of the present invention will become more apparent by describing in detail preferred embodiments thereof with reference to the attached drawings in which:

5           FIG. 1 is a block diagram of a DVD reproducing apparatus according to a preferred embodiment of the present invention;

          FIG. 2 is a reference diagram illustrating a screen alignment order (Z-order) of a display (not shown) connected to the apparatus of FIG. 1;

10           FIG. 3 shows the structures of files of the DVD 100 of FIG. 1 according to a preferred embodiment of the present invention;

          FIG. 4 shows a picture in picture (PIP) mode, as one display mode according to the present embodiment;

          FIG. 5 shows an embedded mode, as one display mode according to the present embodiment;

15           FIG. 6 shows a background mode, as one display mode according to the present embodiment;

          FIG. 7 shows a reference diagram more specifically illustrating a display mode of the AV scene and the markup document scene according to video-viewport: and video-placement:;

20           FIG. 8 shows a reference diagram more specifically illustrating a display mode of the AV scene and the markup document scene according to viewport: and window:;

          FIG. 9 shows a flowchart illustrating a preferred embodiment of a reproducing method according to the present invention;

25           FIG. 10 shows a flowchart specifically illustrating steps subsequent to step 903 of FIG. 9;

          FIG. 11 shows a flowchart illustrating a preferred embodiment of a recording method according to the present invention;

30           FIG. 12 shows a reference diagram illustrating a method for displaying AV data and a markup document while minimizing distortion of interactive contents in various displays having different screen ratios;



FIG. 13 shows a reference diagram illustrating scenes in which AV data for 16 x 9 is displayed on a display for 4 x 3 in a letter box shape and a pan & scan shape;

FIG. 14 shows a reference diagram illustrating a markup document using the concept of a hot area;

FIG. 15 shows variations in coordinate systems needed in mapping the area selected using viewport: to the area designated using window.;

FIG. 16 shows a flowchart of another preferred embodiment of a reproducing method according to the present invention

FIG. 17 shows a reference diagram in which AV data for 16 x 9 is synthesized with a markup document for 4 x 3 in embedded, background, and PIP modes, respectively,

FIG. 18 shows a reference diagram in which the AV data for 16 x 9 is synthesized with the markup document for 4 x 3 in a background mode, and then is displayed on a display for 16 x 9;

FIG. 19 shows a reference diagram illustrating a display, a markup document, and AV data according to different aspect ratios;

FIG. 20 shows a reference diagram illustrating the ratio of width to length in pixels in a display for 16 x 9 and the ratio of width to length in pixels in a display for 4 x 3;

FIG. 21 shows a reference diagram illustrating various aspect ratio conversion;

FIG. 22 shows a reference diagram in which AV data for 16 x 9 and a markup document for 4 x 3 each having a window area are synthesized with each other, and then is displayed on a display for 16 x 9; and

FIG. 23 shows a flowchart of another preferred embodiment of a reproducing method according to the present invention.

30

Best mode for carrying out the Invention

Hereinafter, preferred embodiments of the present invention will be described in detail with reference to the accompanying drawings.

Meanings of terms used in the description are as follows. "Markup document" means a markup document and a markup resource including various image files and graphic files inserted in the markup document. "Markup document scene" means a scene in which "Markup document" is displayed by a viewer. "AV scene" means a scene in which AV data is decoded and displayed. Scene synthesis information means information on the definition of a method for displaying a markup document scene and an AV scene together according to the present invention.

FIG. 1 is a block diagram of a reproducing apparatus according to a preferred embodiment of the present invention. Referring to FIG. 1, the reproducing apparatus displays an AV scene and a markup document scene together, which are obtained by decoding AV data and a markup document recorded on an optical disc 100 according to the present embodiment, in an interactive mode by a displaying method according to the present invention. The reproducing apparatus includes a reading unit 1, an AV decoder 2, a presentation engine 3, and a blender 4.

The reading unit 1 reads AV data, a markup document, and scene synthesis information from the optical disc 100 and provides the read AV data, the read markup document, and the read scene synthesis information to the AV decoder 2 and the presentation engine 3. In addition, the reading unit 1 may include a buffer memory (not shown) and a cache memory (not shown), for buffering the read AV data and caching the read markup document, respectively.

The presentation engine 3 supports a display mode according to the present invention. From the viewpoint of a software unit, the presentation engine 3 includes a viewer, which is an application for interfacing with an operating system of the reproducing apparatus

through an application program interface (API), and a client interpretation engine. The API is a predetermined special method for requesting processing of an operation system or another application. The client interpretation engine is implemented with a JavaScript or Java interpretation engine, interprets a program coded with JavaScript or Java, like a web browser and executes the program. Furthermore, the presentation engine 3 may further include a Plug-In. The Plug-In enables files in various formats included in the markup document or called by the markup document, to open. The presentation engine 3 interprets the scene synthesis information according to the present invention and transmits a decoding command and a display command according to the result of interpretation to the AV decoder 2 and the blender 4, respectively. The presentation engine 3 also provides the markup document scene to the blender 4. The AV decoder 2 decodes the AV data according to the provided decoding command and outputs the decoded AV data to the blender 4. The blender 4 displays the markup document scene and the AV scene together according to the display command.

In order to perform a reproducing method according to an embodiment of the present invention, the presentation engine 3 calls a style sheet linked to or embedded in the markup document manufactured by the reading unit 1 and interprets the style sheet. Information on a method for synthesizing (displaying) the markup document scene and the AV scene is described in the style sheet.

In order to perform the reproducing method according to another embodiment of the present invention, the presentation engine 3 interprets a screen mode (aspect ratio, resolution, and video output mode) set in the reproducing apparatus or set by the user and outputs a command according to the set screen mode using scene synthesis information which is defined using a default style sheet set in the reproducing apparatus or a style sheet provided by a manufacturer (in

particular, using viewport: for designating a trimming area of a scene in which the AV scene and the markup document scene are synthesized with each other, window: for designating a window of the screen in which the AV scene and the markup document scene are synthesized with each other, and video-viewport: for designating an area to increase and reduce a desired portion of the AV scene). If the screen mode is changed by the user, the presentation engine 3 outputs a command according to the changed screen mode using the scene synthesis information (viewport:, window:, and video-viewport:). In addition, a switching unit may be constituted in the AV decoder 2. When a display is set to a 4 x 3 size, the AV decoder 2 converts an AV stream into a letter box or pan & scan shape and outputs the converted AV stream. When the display is set to a 16 x 9 size, the AV decoder 2 outputs the AV stream in a 16 x 9 size without conversion. This is because the AV stream is generally encoded in the 16 x 9 size in the DVD reproducing apparatus. However, when the display mode in the interactive mode is an embedded mode or picture in picture (PIP) mode, the AV decoder 2 can output the AV stream in the 16 x 9 size without converting the AV stream into a letter box or pan & scan shape according to an "Initial Display aspect ratio" in which an aspect ratio preferred by the user is initially set in the presentation engine 3 even in a display for 4 x 3.

That is, preferably, when AV data for 16 x 9 is displayed on the display for 4 x 3, the presentation engine 3 controls the AV decoder 2 to output AV data in a 16 x 9 size in the embedded mode of the interactive mode or PIP mode and to output AV data in a pan & scan or letter box shape in a background mode of the interactive mode or video mode. However, the AV data may be output in the pan & scan or letter box shape from the AV decoder 2 even in the embedded mode of the interactive mode or PIP mode.

In order to perform the reproducing method according to still another embodiment of the present invention, the presentation engine 3

interprets viewport and window (document-viewport:, document-window:) only for the markup document defined in the scene synthesis information, respectively, and viewport and window (video-viewport:, video-window:) only for the AV data. In order to perform the reproducing method  
5 according to yet still another embodiment of the present invention, unlike the AV decoder 2 having a switching unit, even though the display is set to the 4 x 3 size, in the embedded mode or PIP mode, the AV decoder 2 having no additional switching unit outputs the AV stream for 16 x 9, in such a way that the display is set to the 16 x 9 size, without outputting  
10 the AV stream in the letter box or pan & scan shape according to the viewport and window only for the interpreted markup document and the viewport and window only for the AV data.

FIG. 2 is a reference diagram illustrating a scene alignment order (Z-order) of a display (not shown) connected to the reproducing  
15 apparatus of FIG. 1. Referring to FIG. 2, a final scene shown to the user is generated by four scenes added physically. A scene 21 on which a pointer is displayed, is placed foremost, followed by a markup document scene 22 according to the markup document, an AV scene 23 according to the AV data, and a background scene 24 generally  
20 displayed in a single color.

FIG. 3 shows the structures of files of the DVD 100 of FIG. 1 according to a preferred embodiment of the present invention. Referring to FIG. 3, a video directory VIDEO\_TS including AV data, and an interactive directory DVD\_ENAV including data for supporting an  
25 interactive function, such as a markup document, are provided in a root directory. AV data and reproduction control information (also, known as navigation data) are recorded in the video directory VIDEO\_TS. The reproduction control information includes information referred to, so as to decode the AV data. The markup document and the scene synthesis  
30 information are recorded in the interactive directory DVD\_ENAV.

More specifically, a file VIDEO\_TS.IFO in which header information on the entire video title is recorded, is recorded in the video directory VIDEO\_TS. Next, a file VTS\_01\_0.IFO in which header information on a first video title is recorded, is recorded in the video  
5 directory VIDEO\_TS, and then files VTS\_01\_0.VOB, VTS\_01\_1.VOB, . . . , which are AV data for constituting the video title, are recorded in the video directory VIDEO\_TS. A more detailed structure is disclosed in the DVD-Video standard "DVD-Video for Read Only Memory Disc 1.0."

10 A reproduction control information file DVD\_ENAV.IFO in which header information on the entire data for supporting an interactive function is recorded, is recorded in the interactive directory DVD\_ENAV. Only a file DVD\_ENAV.IFO may be replaced with various meta tags of the markup document which performs a start up function. Next, a  
15 markup document A.HTM is recorded in the interactive directory DVD\_ENAV, and a style sheet A.CSS, as scene synthesis information thereon is recorded in the interactive directory DVD\_ENAV. In addition, markup documents B.HTM and C.HTM and style sheets B.CSS and C.CSS corresponding to the markup documents B.HTM and C.HTM are  
20 recorded in the interactive directory DVD\_ENAV. A.PNG, as a graphic file inserted and displayed in the markup document A.HTM, B1.PNG and B2.PNG, as graphic files inserted and displayed in the markup document B.HTM, and C.PNG as a graphic file inserted and displayed in the markup document C.HTM, are recorded in the interactive directory  
25 DVD\_ENAV. Other markup documents and files having various shapes inserted and displayed therein may be recorded in the interactive directory DVD\_ENAV.

FIG. 4 shows a picture in picture (PIP) mode, as one display mode according to the present embodiment. Referring to FIG. 4, in the  
30 PIP mode, an AV scene is output as a PIP on a markup document scene. Only the markup document scene is physically placed in front of the AV

scene, as described with reference to FIG. 2. The PIP mode enables the AV scene to seem to be output on the markup document scene from a user's viewpoint. Preferably, the PIP mode is subdivided by the placement location and size of the AV scene. In the present embodiment, the PIP mode is divided into several shapes using PIP-# such as PIP-1 and PIP-2. In the PIP mode, the user can change the location and size of the AV scene using a remote controller (not shown). Meanwhile, an example of an XML code for constituting the markup document A.HTM shown in FIG. 4 is as follows.

```
<?xml version="1.0"?>
<!DOCTYPE html
PUBLIC "-//DVD//DTD XHTML DVD HTML 1.0//EN"
"http://www.dvdforum/dvdenav/dvdhtml-1-0.dtd">
<html>
  <head>
    <title>DVD HTML PIP mode sample</title>
    <link rel="stylesheet" type="text/css" href="a.css">
  </head>
  <body onload="dvdvideo.play();">
    <table border="0" width="720" height="480">
      <tr>
        <td>
          
        </td>
      </tr>
    </table>
  </body>
</html>
```

10

A. HTM

It is apparent that a style sheet file A.CSS is linked to the above source code using a link tag. An example of a style sheet source code is as follows.

```
@screen-display
{
video-placement: pip
background-color: #00000000
viewport : rect(0px,719px,479px,0px)
window: rect(0px,719px,479px,0px)
video-viewport: rect(0px,719px,479px,0px)
}
```

15

A. CSS

In the present embodiment, a cascading style sheet (CSS) uses @screen\_display rule as above, so as to use a display mode between the markup document scene and the AV scene. Properties such as **video-placement**: for designating a display mode of the AV scene, **background-color**: for designating a background color of the AV scene, **viewport**: for designating a trimming area of a scene in which the AV scene is synthesized with the markup document scene, **window**: for designating a window of the scene in which the AV scene is synthesized with the markup document scene, and **video-viewport**: for designating an area to increase and reduce a desired portion of the AV scene, are described.

FIG. 5 shows an embedded mode, as one display mode according to the present embodiment. Referring to FIG. 5, in the embedded mode, the AV scene is embedded in the markup document through <object . . . >. Thus, the location and size of the AV scene is moved and changed under control of the markup document. In the embedded mode, the AV scene is embedded and displayed in a display window defined by the markup document. An example of an XML code for constituting the markup document B.HTM shown in FIG. 5 and an example of a style sheet source code are as follows.

```

<?xml version="1.0"?>
<!DOCTYPE html
  PUBLIC "-//DVD//DTD XHTML DVD HTML 1.0//EN"
  "http://www.dvdforum/dvdenav/dvdhtml-1-0.dtd">
<html>
  <head>
    <title>DVD HTML Embedded sample</title>
    <link rel="stylesheet" type="text/css" href="b.css">
  </head>
  <body onload="dvdvideo.play();">
    <table border="0" width="720" height="480">
      <tr>
        <td width="277" height="184" align="left" valign="top">
          <object data="dvd:" width="277" height="184" border="0"/>
        </td>
        <td width="443" height="480" align="left" valign="top" rowspan="2">
          
        </td>
      </tr>
    </table>
  </body>
</html>

```



```

<tr>
  <td width="277" height="296">
    
  </td>
</tr>
</table>
</body>
</html>

```

## B.HTM

```

@screen-display
{
video-placement: embedded
background-color: #00000000
viewport : rect(0px,719px,479px,0px)
window: rect(0px,719px,479px,0px)
video-viewport: rect(0px,719px,479px,0px)
}

```

## B.CSS

A display window in which the AV scene is to be displayed using an object tag, is defined in B.HTM. That is, the area of the display window is determined by properties such as "width" and "height" in the "object" tag. In addition, it is apparent that a style sheet file B.CSS is linked to B.HTM using a link tag. Here, B.CSS means a cascading style sheet (CSS) file. CSS enables "style" of the markup document to be described. Alternatively, the style sheet file can be linked to B.HTM using a style tag.

FIG. 6 shows a background mode, as one display mode according to the present embodiment. Referring to FIG. 6, in the background mode, the markup document scene is output on the AV scene. An example of an XML code for constituting the markup document C.HTM shown in FIG. 6 and an example of a style sheet source code are as follows. Similarly, a style sheet file C.CSS is linked to C.HTM using the link tag.

```

<?xml version="1.0"?>
<!DOCTYPE html
  PUBLIC "-//DVD//DTD XHTML DVD HTML 1.0//EN"
  "http://www.dvdforum/dvdenav/dvdhtml-1-0.dtd">
<html>
  <head>
    <title>DVD HTML Background sample</title>
    <link rel="stylesheet" type="text/css" href="c.css">

```

```

</head>
<body onload="dvdvideo.play();">
  <table id="mainscreen" border="0" width="720" height="480">
    <tr>
      <td width="388" height="300">
        <p>&nbsp;</p>
      </td>
      <td width="322" height="300">
        <p>&nbsp;</p>
      </td>
    </tr>
    <tr>
      <td width="388" height="180">
        <p>&nbsp;</p>
      </td>
      <td width="388" height="180">
        <div>
          
        </div>
      </td>
    </tr>
  </table>
</body>
</html>

```

## C.HTM

```

@screen-display
{
  video-placement: background
  background-color: #00000000
  viewport : rect(0px,719px,479px,0px)
  window: rect(0px,719px,479px,0px)
  video-viewport: rect(0px,719px,479px,0px)
}
body {background-color:transparent;}
table#mainscreen {background-color:transparent;}

```

## C.CSS

Next, properties and values used as @screen\_display rule  
 5 representing a display mode between the markup document scene and  
 the AV scene are as follows.

1. **video-placement:** It designates a display mode of the AV  
 scene. None, embedded, pip-#, and background represent nothing  
 displayed, embedded mode, PIP mode, and background mode,  
 10 respectively. An initial value is an embedded mode.

Here, the background mode is discriminated from a background  
 <body background ="dvd:"> using a body tag. <body background

= "dvd:"> represents a background in a window defined to output the markup document scene. That is, in the background mode according to the present embodiment, the AV scene is displayed in the entire scene but if the background using the body tag is designated, the AV scene is displayed only in a predetermined window scene.

2. **background-color:** It designates a background color of a scene formed of a single color. A value is <color>, and an initial value may vary according to a user agent (UA).

3. **window:** It designates a window in which a scene where the AV scene is synthesized with the markup document scene, is displayed. A value is <shape>, and an initial value is rect (0%, 100%, 100%, 0%).

4. **viewport:** It designates a trimming area of the scene in which the AV scene is synthesized with the markup document scene. A value is <shape>, and an initial value is rect (0%, 100%, 100%, 0%).

5. **video-viewport:** It designates an area to increase and reduce a desired portion of the AV scene. A value is <shape>, and an initial value is rect (0%, 100%, 100%, 0%). Here, the value of the defined <shape> is rectangle (<top>, <right>, <bottom>, <left>).

FIG. 7 shows a reference diagram more specifically illustrating a display mode of the AV scene and the markup document scene according to video-viewport: and video-placement:. Referring to FIG. 7, if an area **a** for increasing and reducing from the AV scene is designated by video-viewport:, when video-placement: is a background mode, a trimming area **a** is displayed in a background scene, and a markup document scene (not shown) is displayed in the trimming area **a**. When video-placement: is a PIP mode, the trimming area **a** is displayed in a designated location. When video-placement: is an embedded mode, the trimming area **a** is embedded in a display window defined by a markup document and is displayed in the display window. FIG. 7 shows

an example in which only partial area of the AV data is selected, that is, the area of video-viewport: is selected as a partial area such that the partial area is mapped to the area of window: defined by each display mode.

5           FIG. 8 shows a reference diagram more specifically illustrating a display mode of the AV scene and the markup document scene according to viewport: and window:. In the case of a property viewport: selected to display a trimming area of contents of the scene in which the AV scene is synthesized with the markup document scene on a scene of  
10 a display, and a property window: for designating a window area so that all or part of a selected document can be displayed in a predetermined scene area on a display screen, values of viewport: and window: are used without change. Only, FIG. 8 shows an example illustrating that only partial area of the scene in which the AV scene is synthesized with  
15 the markup document scene is selected, that is, the area of video-viewport: is selected as a partial area such that the partial area is mapped to the area of window: defined by each display mode. Thus, concepts of viewport: and window: allow part or all of the scene in which the AV scene is synthesized with the markup document scene to  
20 increase/reduce.

Referring to FIG. 8, in the embedded mode in which the AV scene is embedded in the markup document scene and is displayed, if a trimming area **b** of the scene in which the AV scene is synthesized with the markup document scene is designated by viewport:, the trimming  
25 area **b** is displayed in the window designated by window:, as shown by (1). When the entire markup document is set to viewport:, the trimming area **b** is displayed in the window designated by window:, as shown by (2). If a background using a body tag is designated, the entire synthesized scene is displayed in the window designated by window:.

A property variable for designating a display mode, a property variable for designating a background color of an AV scene, a property variable for designating a window of a scene in which the AV scene is synthesized with a markup document scene, a property variable for designating a trimming area of the scene in which the AV scene is synthesized with the markup document scene, and a property variable for designating an area to increase and reduce a desired portion of the AV scene are defined in an object for controlling the above-mentioned CSS file.

In addition, the AV scene may be increased/reduced according to a user's input using an object source code of an application program interface (API) for a document object model (DOM). The value of the object source code needed in performing this operation can be referred to using a script language in the markup document.

The following object source code is used to bind "ScreenDisplayProperties" in root elements (i.e., <frameset> and <html>) of the uppermost level.

```
Interface ScreenDisplayProperties {
    attribute ScreenDisplayRule screenDisplayInfo;
}
```

Here, "ScreenDisplayProperties" are connected to root elements of a markup document, and the value of "ScreenDisplayProperties" can be referred to using a script language in the markup document. An example of the object source code is as follows.

```
IDL Definition
Interface ScreenDisplayRule
{
    attribute unsigned short videoPlacement;
    attribute DOMString      colorBackground;
    attribute DOMString      viewport;
    attribute DOMString      window;
    attribute DomSting       videoViewport;
};

Attributes
videoPlacement: It designates a display mode of a DVD-video. That is, it represents that
const unsigned short VIDEO_PLACEMENT_NONE = 0;
const unsigned short VIDEO_PLACEMENT_EMBEDDED = 1;
```

```
const unsigned short VIDEO_PLACEMENT_BACKGROUND = 2;
const unsigned short VIDEO_PLACEMENT_PIP = 3; .
```

colorBackground: It has the value of <color> as a background color of an AV scene.  
viewport: It has the value of <shape> as a trimming area of a synthesized scene.

window: It has the value of <shape> as a window area on a display to which the trimmed synthesized scene is to be mapped.

videoViewport: It has the value of <shape> as a trimming area of the AV scene.

A static definition using a tag <meta> or <link> as well as a dynamic definition using the above object source are possible.

- 5 Meanwhile, a script language included in the markup document is used to increase/reduce the output AV scene according to a user's input using the object source of the API for a DOM described above. The following example is an example in which a manufacturer can increase/reduce the AV scene displayed in an embedded state, as shown in FIG. 8.

```
<?xml version = "1.0" encoding="UTF-8"?>
<!DOCTYPE html PUBLIC "-//DVD//DTD XHTML DVD-HTML 1.0//EN"
    "http://www.dvdforum.org/envideo/dtd/dvdhtml-1.0.dtd">
<html>
  <head>
    <title>Example of Scaling</title>
    <script type=" text/ecmascript">
      <--
        function zoom(evt)
        {
          var vdi;

          if (evt == 0)
          { // evt == 0 : Increase an AV scene to a designated size
            vdi = document.documentElement.screenDisplayInfo;
            vdi.videoPlacement = 1;
            vdi.colorbackground = "black";
            vdi.videoviewport = "rect(10px,709px,469px,10px)"
            // In an embedded state, vdi.window is determined by "width" and "height" of
            a tag "Object" in a markup document. That is, rect(0%,100%,100%,0%) is consistent
            with sizes of "width" and "height" defined by the tag "Object".
          }

          if (evt == 1)
          { // evt == 1 : as original
            vdi = document.documentElement.screenDisplayInfo;
            vdi.videoPlacement = 1;
            vdi.colorbackground = "black";
            vdi.videoviewport = "rect(0px,719px,479px,0px)"
          }
        }
      -->
    </script>
  </head>
</html>
```

```

    if (evt == 2)
    { // evt == 2 : Reduce an AV scene to a designated size
      vdi = document.documentElement.screenDisplayInfo;
      vdi.videoPlacement = 1;
      vdi.colorbackground = "black";
      vdi.videoviewport = "rect(0px,719px,479px,0px)"
      vdi.window="rect(10%,90%,90%,10%)
      // Here, a % value is a relative value for "width" and "height" defined by the
tag "Object".
    }
  }
  -->
</script>
</head>
<body onload="dvdvideo.play();">
<table border="0" width="720" height="480">
  <tr>
    <td width="277" height="184" align="left" valign="top">
      <object data="dvd": width="277" height="184" border="0"/>
    </td>
    <td width="443" height="480" align="left" valign="top" rowspan="2">
      
    </td>
  </tr>
  <tr>
    <td width="277" height="296">
      <input type="button" value="Zoom-In" onClick="zoom(0)"/>
      <input type="button" value="Restore" onClick="zoom(1)"/>
      <input type="button" value="Zoom-Out" onClick="zoom(2)"/>
    </td>
  </tr>
</table>
</body>
</html>

```

In this way, the scale of the AV scene can be manipulated through a user's input using the API for a DOM and the script language.

Accordingly, the AV scene and the markup document scene are freely synthesized with each other according to the above-mentioned  
 5 embodiment, and the display location of the AV scene can be set by a style sheet linked to the markup document or embedded in the markup document, thereby allowing a user to enjoy scenes in various shapes.

A reproducing method according to the present invention will be described below based on the above structure.

10 FIG. 9 shows a flowchart illustrating a preferred embodiment of a reproducing method according to the present invention. Referring to

FIG. 9, in step 910, the reading unit 1 of the reproducing apparatus reads a markup document, which is to be reproduced with AV data, from the optical disc 100. The presentation engine 3 interprets the read markup document in step 902 and calls a style sheet file linked to the markup document in step 903. Subsequently, the presentation engine 3 interprets the style sheet file and provides the result of interpretation to the AV decoder 2 in step 904. More specifically, the presentation engine 3 reads display mode designation information for designating a displaying mode of the AV scene described in the style sheet file, background color designation information for designating a background color of the AV scene, window designation information for designating a window in which a scene where the AV scene is synthesized with the markup document is displayed on the screen of the display, trimming area designation information of the synthesized scene for designating a trimming area of the scene in which the AV scene is synthesized with the markup document, and AV trimming area designation information for designating an area to increase and reduce a desired portion of the AV scene, from the optical disc 100. The AV decoder 2 decodes the AV data according to the style sheet file and outputs a corresponding AV scene to the blender 4. The presentation engine 3 outputs a command for displaying the markup document scene and the AV scene, and the markup document scene in which the markup document is reproduced, to the blender 4 according to the description in the style sheet file. For this purpose, the presentation engine 3 interprets a program, which is coded on the basis of an object having property variables for controlling the style sheet file and controls the style sheet file. The blender 4 blends and outputs the markup document and the AV scene, which are provided from the presentation engine 3 and the AV decoder 2, respectively. In step 905, the AV scene and the markup document scene are displayed according to interpreted scene synthesis information. In step 905-1, when the PIP mode is described in the style



sheet file, the AV scene is overlapped on the markup document scene and is displayed. In step 905-2, when the embedded mode is described in the style sheet file, the AV scene is embedded in the markup document scene and is displayed. In step 905-3, when the background mode is described in the style sheet file, the markup document scene is overlapped on the AV scene and is displayed.

FIG. 10 shows a flowchart specifically illustrating steps subsequent to step 903 of FIG. 9. Referring to FIG. 10, the presentation engine 3 interprets the CSS file in the markup document or the link tag and calls the CSS file in step 1001, interprets the called CSS file in step 1002, and reads the display mode designation information and the AV trimming area designation information, which are described in the CSS file in step 1003. The blender 4 blends and outputs the command and the markup document scene provided from the presentation engine 3 and the AV scene provided from the AV decoder 2, and the markup document scene and the AV scene are displayed according to the display mode described in the CSS file in step 1004. In the case of a none mode, the AV scene is not displayed in step 1004-1. Otherwise, one of the PIP mode (step 1004-2), the background mode (step 1004-3), and the embedded mode (step 1004-4) may be displayed.

FIG. 11 shows a flowchart illustrating a preferred embodiment of a recording method according to the present invention. Referring to FIG. 11, the recording apparatus records the AV data on an information storage medium (step 1101), records the markup document that is to be reproduced with the AV data on the information storage medium (step 1102), and records the above-mentioned scene synthesis information in the style sheet file linked to or embedded in the markup document (step 1103). In step 1103, an object having property variables for controlling the style sheet file in the markup document and a program for controlling

the style sheet file on the basis of the object are recorded on the information storage medium.

Until now, there have been described embodiments in which the scene where the markup scene is synthesized with the AV scene is increased/ reduced using the properties window: and viewport: of the scene synthesis information, part of the AV scene is increased/reduced using the property video-viewport: such that the AV data and the markup document are displayed in various ways in the interactive mode.

Hereinafter, an embodiment of a method for displaying the AV data and the markup document in various ways in the interactive mode according to resolution and an aspect ratio (screen ratio) set by the user or in the reproducing apparatus using the properties window: and viewport: of the above-mentioned scene synthesis information will be described. When the markup document manufactured to have a fixed screen ratio in the present invention is displayed on a display having different aspect ratios, a scene distortion phenomenon by which part of data such as text or graphics to be displayed on a display screen is wrongly displayed may occur. Thus, in the present invention, the distortion of the scene is minimized to correspond to a screen mode (aspect ratio, resolution, and video output method) set by the user or already set in the reproducing apparatus by changing interactive contents manufactured at one fixed screen ratio to have various screen ratios using the properties window: and viewport:.

First, methods for displaying interactive contents manufactured using a markup language in several displays having different screen aspect ratios while minimizing distortion of the interactive contents will be described with reference to FIG. 12. To meet the convenience of explanation, the ratio of pixel size in all cases is set to 1 x 1.

First displaying method: A manufacturer prepares respective markup documents and respective AV data by considering several

screen aspect ratios so as to correspond to a display having different aspect ratios.

In order to display interactive contents that are not distorted in the display having different aspect ratios as shown by ① and ②, the manufacturer prepares respective markup documents by considering  
5 different aspect ratios of the display as shown by ③ and ④, and respective AV data (i.e., AV contents of DVD-video format) by considering different aspect ratios of the display as shown by ⑤ and ⑥. Contents of ③ + ⑤ in which AV data for 4 x 3 is synthesized with a  
10 markup document for 4 x 3 can be displayed on the screen of a display for 4 x 3 as shown by ①, and contents of ④ + ⑥ in which AV data for 16 x 9 is synthesized with a markup document for 16 x 9 can be displayed on the scene of a display for 16 x 9 as shown by ②, as contents which the manufacturer wants, without performing any special  
15 operation.

Second displaying method: The manufacturer prepares respective markup documents by considering aspect ratios of a display, and AV data corresponds to a display having different aspect ratios in the following way when contents having a fixed aspect ratio are  
20 manufactured.

When only ③, ④, and ⑤ are manufactured

- When displaying on a display for 4 x 3: The contents of ③ + ⑤ in which the AV data for 4 x 3 is synthesized with the markup document for 4 x 3 can be displayed in a scene ①, as contents which  
25 the manufacturer wants, without performing any special operation.

- When displaying on a display for 16 x 9: The AV data ⑤ for 4 x 3 is embedded in the markup document for 16 x 9 including right and left blanks without expansion. Only the right and left blanks may be eliminated by setting the size of an object tag of the markup

document for 16 x 9 so that the AV data for 4 x 3 can be embedded in the markup document for 16 x 9. The contents of ④ + ⑤ can be displayed in a scene 2, as contents which the manufacturer wants, without performing any special operation.

5           When only ③, ④, and ⑥ are manufactured

- When displaying on a display for 4 x 3: AV data 6 for 16 x 9 is converted into a shape of a 4 x 3 normal scene, 4 x 3 letter box scene, or 4 x 3 pan & scan scene and then is embedded in a markup document 3 for 4 x 3. The manufactured contents of ③ + ⑥ can be  
10 displayed in a scene 1, as contents which the manufacturer wants, without performing any special operation.

Here, a full screen scene is referred to as a standard scene and is manufactured and reproduced at an aspect ratio of 4 x 3 (1.33:1). A full normal scene is displayed on a display for 4 x 3. A black band appears  
15 at both ends of a scene of a display for 16 x 9. If a user views a full scene on a display screen for 16 x 9 (wide mode: (a) of FIG. 13), a picture seems to be horizontally spread, and if the user views the scene in a zoom mode, the upper and lower portions of the scene are cut off. In the two cases, a picture is simply increased and thus resolution is  
20 lower.

Pan & scan is a picture manufactured by cutting both sides of a picture manufactured in a wide scene format (16 x 9) and selecting only a middle portion of a scene corresponding to an aspect ratio of 4 x 3 (1.33:1), as shown in (b) of FIG. 13, and a method for reproducing pan &  
25 scan is the same as that of a full screen.

A letter box scene has an advantage that the user can appreciate a scene as being run in a movie theater but has a disadvantage that the size of the scene is reduced. Thus, in a pan & scan method, both ends of an unimportant scene are cut off, and a picture is filled in a 4 x 3  
30 scene rather than a scene is reduced and displayed. There may be a

difference in picture beauty of the 4 x 3 pan & scan scene depending on an editor's skill.

Letter box is a picture manufactured by inserting a black band in upper and lower portions of a scene and reducing the scene so that the user can effectively view a picture manufactured in a wide scene format (16 x 9) in a normal display (screen ratio 4 x 3). The upper and lower black bands of the picture are referred to as "Matte".

- When displaying on a display for 16 x 9: The contents of ④ + ⑥ in which AV data for 16 x 9 is synthesized with a markup document for 16 x 9, can be displayed in a scene 2, as contents which the manufacturer wants, without performing any special operation.

Third displaying method: The manufacturer prepares respective AV data by considering aspect ratios of a display, and a markup document corresponds to a display having different aspect ratios in the following way when contents having a fixed aspect ratio are manufactured.

When only ③, ⑤, and ⑥ are manufactured

- When displaying on a display for 4 x 3: The contents of ③ + ⑤ in which AV data for 4 x 3 is synthesized with a markup document for 4 x 3, can be displayed in a scene 1, as contents which the manufacturer wants, without performing any special operation.

- When displaying on a display devcie for 16 x 9: AV data 6 for 16 x 9 is converted into a shape of a 4 x 3 normal scene, 4 x 3 letter box scene, or 4 x 3 pan & scan scene and then is embedded in a markup document 3 for 4 x 3. The manufactured contents of 3 + 6 can be displayed to include blanks on the right and left sides of a scene 2 through middle alignment.

When only ④, ⑤, and ⑥ are manufactured

- When displaying on a display for 4 x 3: AV data 5 for 4 x

3 is embedded in a markup document 4 for 16 x 9 to include right and left blanks without expansion. The resolution of the manufactured contents of ④ + ⑤ is, for example, 854 x 480, and thus only an important screen portion can be displayed in a scene ① of a display for 5 4 x 3 through a concept of "hot area" and an API with respect to aspect ratio conversion.

- When displaying on a display for 16 x 9: The contents of ④ + ⑥ in which AV data for 16 x 9 is synthesized with a markup document for 16 x 9, can be displayed in a scene ② as the 10 manufacturer wants, without performing any special operation.

Fourth displaying method: When each of AV data and a markup document is manufactured at one aspect ratio, the AV data and the markup document correspond to a display having different aspect ratios in the following way.

15 - When only ③ and ⑤ are manufactured  
- When displaying on a display for 4 x 3: The contents of ③ + ⑤ in which AV data for 4 x 3 is synthesized with a markup document for 4 x 3, can be displayed in a scene ①, as contents which the manufacturer wants, without performing any special operation.

20 - When displaying on a display for 16 x 9: Through the middle alignment of the entire contents of ③ + ⑤ in which AV data for 4 x 3 is synthesized with a markup document for 4 x 3, the contents of ③ + ⑤ can be displayed to include blanks on the right and left sides of a scene ② of a display for 16 x 9.

25 When only ④ and ⑥ are manufactured

- When displaying on a display for 4 x 3: The resolution of the manufactured contents of ④ + ⑥ in which AV data for 16 x 9 is synthesized with a markup document for 16 x 9, is 854 x 480, and thus only an important screen portion can be displayed in a scene ① of a

display for 4 x 3 through a concept of "hot area" and an API with respect to aspect ratio conversion. In this case, preferably, the pan & scan or letter box is applied to the video mode other than the interactive mode.

- When displaying on a display for 16 x 9: The contents of  
5 ④ + ⑥ in which AV data is synthesized with a markup document, can be displayed in a scene ② as the manufacturer wants, without performing any special operation.

Here, "hot area" and the API with respect to the aspect ratio conversion will be described in greater detail.

10 When interactive contents manufactured for use in 16 x 9 (resolution of 854 x 480) are displayed on a display for 4 x 3 (resolution of 640 x 480), only a 640 x 480 area of the entire area of the interactive contents is displayed on the display for 4 x 3, the other 214 x 480 area is not displayed on the display for 4 x 3. Therefore, the manufacturer  
15 includes contents which should be displayed on a 640 x 480 area (in the present invention, the displayed maximum area is referred to as "hot area" regardless of an aspect ratio of a display), which can be displayed regardless of an aspect ratio of a display during initial layout, and includes unimportant contents or does not include any contents in the  
20 other area. In order to display a markup document manufactured by the concept of "hot area" on a display for 4 x 3 and in order to display an AV scene and a markup document scene in various ways, interactive contents are displayed using the above-mentioned properties "viewport:" and "window:" used in the object source code of the API for a DOM, and  
25 descriptions thereof will be described later.

Hereinafter, a simple example in which interactive contents for 16 x 9 are displayed on a display for 4 x 3 regardless of an aspect ratio of a display, will be described with reference to FIG. 14.

The manufacturer constitutes a markup document using the  
30 concept of "hot area" so as to display a scene that is not distorted

regardless of various aspect ratios of a display. That is, in a document space of a markup document shown in FIG. 14, the entire markup document manufactured for 854 x 480 will be displayed on a display for 16 x 9, and the contents of a 640 x 480 "hot area" will be displayed on a display for 4 x 3. Here, the size of the "hot area" is not fixed but exemplifies 640 x 480, as a size for minimizing distortion, and its location is also not fixed.

In addition, in the markup document space manufactured for 16 x 9, the manufacturer uses the property viewport: so as to select the "hot area" that is set not to be distorted and displayed on the display for 4 x 3, and maps to a designated area of a scene using the property window: so as to display the selected "hot area" on the display for 4 x 3.

FIG. 15 shows variations in coordinate systems needed in mapping the area selected using viewport: to the area designated using window:

$$X_{window} = \frac{(X_{document} - X_{viewport\_origin})}{Width_{viewport}} \times Width_{window} \quad \dots \quad (1)$$

$$Y_{window} = \frac{(Y_{document} - Y_{viewport\_origin})}{Width_{viewport}} \times Height_{window} \quad \dots \quad (2)$$

The above Equations 1 and 2 show that one point ( $X_{document}$ ,  $Y_{document}$ ) of a document coordinate system is mapped to one point ( $X_{window}$ ,  $Y_{window}$ ) of a corresponding window coordinate system.

$$X_{screen} = X_{window} + X_{window\_origin} \quad \dots \quad (3)$$

$$Y_{screen} = Y_{window} + Y_{window\_origin} \quad \dots \quad (4)$$

The above Equations 3 and 4 show that one point ( $X_{window}$ ,  $Y_{window}$ ) of a window coordinate system obtained by Equations 1 and 2 is mapped to one point ( $X_{screen}$ ,  $Y_{screen}$ ) of a corresponding screen coordinate system of a display.



The above Equations 1 through 4 are based on a markup document, but if a lower subscript “document” is changed into “video”, the definition of AV data is made.

5 An example of an optimum table showing the size of each area through the above-mentioned displaying methods at a pixel size ratio of 1 x 1 to easily recognize a document area, a viewport area, a window area, and a screen area and the size of an area through other available displaying methods is as follows.

Case	Document area	Viewport Area	Window area	Screen Area
When interactive contents manufactured for 640 x 480 are displayed on a 640 x 480 display	640 x 480	640 x 480	640 x 480	640 x 480
When interactive contents manufactured for 640 x 480 are displayed on a 854 x 480 display	640 x 480	640 x 480	640 x 480	854 x 480
When interactive contents manufactured for 640 x 480 are displayed on a 854 x 480 display	640 x 480	640 x 480	854 x 480	854 x 480
When interactive contents manufactured for 854 x 480 are displayed on a 640 x 480 display	854 x 480	854 x 480	640 x 480	640 x 480
When interactive contents manufactured for 854 x 480 are displayed on a 640 x 480 display	854 x 480	854 x 480	640 x 480	640 x 480
When interactive contents manufactured for 854 x 480 are displayed on a 640 x 480 display	854 x 480	640 x 480	640 x 480	640 x 480
When interactive contents manufactured for 854 x 480 are displayed on a 640 x 480 display	854 X 480	854 x 480	854 x 480	854 x 480

10 Meanwhile, reproducing methods according to an aspect ratio are largely classified by a static method using a CSS and a dynamic method using an API for a DOM. When interactive contents are initially

displayed in a scene, the interactive contents are displayed on a display through a static method using a default style sheet in a presentation engine or a CSS defined by link and style tags in a markup document. However, when an aspect ratio is changed by a user's input during reproduction, the aspect ratio of an output screen can be dynamically changed by adding an aspect ratio conversion function using a script language to the markup document using the API for a DOM.

Hereinafter, a static method using @screen-display rule will be described. A property **screen-display type:** is added to @screen-display rule according to another embodiment of the present invention.

1. **screen-display type:** It designates the aspect ratio of a scene in which an AV scene is synthesized with a markup document.

4 x 3N: If a user sets a screen output to a 4 x 3 normal shape

4 x 3L: If a user sets a screen output to a 4 x 3 letter box shape

4 x 3P: If a user sets a screen output to a 4 x 3 pan & scan shape

16 x 9W: If a user sets a screen output to a 16 x 9 wide shape

2. **video-placement:** It designates a display mode of the AV scene. None, embedded, pip-#, and background represent nothing displayed, embedded mode, PIP mode, and background mode, respectively. An initial value is an embedded mode.

3. **video-viewport:** It designates an area to increase and reduce a desired portion of the AV scene. A value is <shape>, and an initial value is rect (0%, 100%, 100%, 0%). Here, the value of the defined <shape> is rectangle (<top>,<right>,<bottom>,<left>).

4. **background-color:** It designates a background color of a scene formed of a single color. A value is <color>, and an initial value may vary according to a user agent (UA).

5. **window:** It designates a window in which a scene where

the AV scene is synthesized with the markup document scene, is displayed. A value is <shape>, and an initial value is rect (0%, 100%, 100%, 0%).

6. **viewport**: It designates a trimming area of the scene in which the AV scene is synthesized with the markup document scene. A value is <shape>, and an initial value is rect (0%, 100%, 100%, 0%).

```

@screen-display 4x3N
{
background-color : #000000
viewport : (0px,629px,479px,90px)
window : (0px,719px,479px,0px)
video-viewport : (0px,719px,479px,0px)
}

@screen-display 4x3L
{
background-color : #000000
viewport : (0px,719px,479px,0px)
window : (60px,719px,419px,0px)
video-viewport : (0px,719px,479px,0px)
}

@screen-display 4x3P
{
background-color : #000000
viewport : (0px,629px,479px,90px)
window : (0px,719px,479px,0px)
video-viewport : (0px,629px,479px,90px)
}

@screen-display 16x9W
{
background-color : #000000
viewport : (0px,719px,479px,0px)
window : (0px,719px,479px,0px)
video-viewport : (0px,719px,479px,0px)
}

```

- 10 Since the default style sheet is differently set in each reproducing apparatus, a scene cannot be usually displayed as the manufacturer wants. Thus, preferably, the manufacturer makes an additional CSS in the markup document and attaches the CSS to the document so that the user can effectively display the AV data (DVD-video) and the markup document manufactured at a fixed aspect ratio, even at an aspect ratio

set by the user. The following example shows that the manufacturer makes the CSS in the markup document so that AV data (DVD-video) for 16 x 9 and a markup document for 4 x 3 can be effectively displayed in a "background mode". The CSS may be made using a "style" tag, as shown the following example, and may be used through external reference using a "link" tag.

```

<!DOCTYPE html PUBLIC "-//DVD//DTD XHTML DVD-HTML 1.0//EN"
    "http://www.dvdforum.org/enav/dtd/dvdhtml-1-0.dtd">
<html>
  <head>
    <title>Example of aspect ratio change</title>
    <style type="text/css">
      @screen-display 4x3N
      {
        video-placement : background
        background-color : #000000
        viewport : (0px,719px,479px,0px)
        window : (0px,719px,479px,0px)
        video-viewport : (0px,629px,479px,90px)//If the entire area is selected using
a viewport area, DVD-video displayed as a background seems to be slim. Thus, in order
to solve this problem, the manufacturer just selects pan & scan. A selection area may
be varied by the manufacturer.
      }

      @screen-display 4x3L
      {
        video-placement : background
        background-color : #000000
        viewport : (0px,719px,479px,0px)
        window : (60px,719px,419px,0px)
        video-viewport : (0px,719px,479px,0px)
      }

      @screen-display 4x3P
      {
        video-placement : background
        background-color : #000000
        viewport : (0px,719px,479px,0px)
        window : (0px,719px,479px,0px)
        video-viewport : (0px,629px,479px,90px) // An area formed by cutting the
right and left sides of DVD-video will be selected.
      }

      @screen-display 16x9W
      {
        video-placement : background
        background-color : #000000
        viewport : (0px,719px,479px,0px)
        window : (0px,629px,479px,90px) // In order to prevent a markup document
from distorting, a window area is reduced.
        video-viewport : (0px,719px,479px,0px)
      }
    </style>
  </head>
</html>

```

```

    }
  </style>
</head>
<body id="bodyNode">
.....
</body>
</html>

```

5 In this way, documents initially displayed by statically applying the CSS are displayed in a scene through the structure of processing shown in the following table in the presentation engine, and a corresponding page of a document of which aspect ratio is changed during reproduction should be reloaded to guarantee a right scene. If the corresponding page of the document is not reloaded and is displayed in the scene, the scene of the markup document may be distorted, or the markup document may be not mapped to the AV data.

```

If (Initial Display aspect ratio==4x3 && (no_video == 1  current display == normal))
{
  apply@screen-display 4x3N
else if (Initial Display aspect ratio==4x3 && current display == 4x3P)
{
  apply@screen-display 4x3P
else if (Initial Display aspect ratio==4x3 && current display == 4x3L)
{
  apply@screen-display 4x3L
else if (Initial Display aspect ratio==16x9)
{
  apply@screen-display 16x9W
}
}

```

10 In the above algorithm in the presentation engine, "Initial Display aspect ratio" corresponds to Initial Display aspect ratio of a system parameter SPRM(14) defined in DVD Specifications for Read-Only Disc/Part 3. "Initial Display aspect ratio" is a parameter obtained by initially setting an aspect ratio which the user prefers and has the values of two types of 4 x 3 and 16 x 9, as shown in the above algorithm.

15 A "no\_video" element indicates whether there is AV data (i.e., DVD-video) in a markup document loaded initially. If the value of "no\_video" element is "0", it is determined that DVD-video is included in

the markup document, and if the value of the "no\_video" element is "1", it is determined that DVD-video is not included in the markup document.

"current display" is a parameter representing an output mode (normal, 4 x 3P, and 4 x 3L) of video in the current domain and is defined in

5 SPRM(14) of DVD Specifications for Read-Only Disc/Part 3.

As above, the static method for displaying interactive contents according to a screen aspect ratio using the default style sheet or the CSS attached to the document by the manufacturer has been described.

The following object source code is used to bind  
10 "ScreenDisplayProperties" in root elements (i.e., <frameset> and <html>) of the uppermost level.

```
Interface ScreenDisplayProperties {
    attribute ScreenDisplayRule screenDisplayInfo;
};
```

ScreenDisplayProperties are connected to root elements of the markup document, and the value of ScreenDisplayProperties can be referred to using a script language in the markup document.

#### IDL Definition

```
Interface ScreenDisplayRule
{
    readonly attribute unsigned short screenDisplayMode;
    attribute unsigned short videoPlacement;
    attribute DOMString colorBackground;
    attribute DOMString viewport;
    attribute DOMString window;
    attribute DOMString videoviewport;
};
```

#### Attributes

screenDisplayMode: Aspect ratio of an output screen set by the user  
const unsigned short SCREEN\_DISPLAY\_MODE\_4X3NORMAL = 0;  
const unsigned short SCREEN\_DISPLAY\_MODE\_4X3LETTERBOX = 1;  
const unsigned short SCREEN\_DISPLAY\_MODE\_4X3PAN&SCAN = 2;  
const unsigned short SCREEN\_DISPLAY\_MODE\_16X9WIDE = 3;

videoPlacement: It designates a display mode of the AV scene  
const unsigned short VIDEO\_PLACEMENT\_NONE = 0;  
const unsigned short VIDEO\_PLACEMENT\_EMBEDDED = 1;  
const unsigned short VIDEO\_PLACEMENT\_BACKGROUND = 2;  
const unsigned short VIDEO\_PLACEMENT\_PIP = 3;

colorBackground: It has the value of <color> as a background color of an AV scene.

viewport: It has the value of <shape> as a trimming area of a markup document.

window: It has the value of <shape> as a window area on a display to which the trimmed markup document is to be mapped.

videoviewport: It has the value of <shape> as a trimming area of AV data.

- The above-mentioned dynamic definition using the object source of the API for the DOM is implemented by a script language included in the markup document, as shown in the following example. The example is made by the manufacturer by considering event handling according to user's aspect ratio conversion of AV data for 16 x 9 (i.e., DVD-video) and a markup document for 16 x 9, which are to be displayed in an embedded mode.

```
<?xml version "1.0" encoding="UTF-8"?>
<!DOCTYPE html PUBLIC "-//DVD//DTD XHTML DVD-HTML 1.0//EN"
      http://www.dvdforum.org/envideo/dtd/dvdhtml-1-0.dtd">
<html>
  <head>
    <title>Example of aspect ratio change</title>
    <script type="text/javascript">
      <--
        function eventHandler(evt)
        {
          var vdi;

          if (evt.index == SCREEN_DISPLAY_MODE_CHANGE && (evt.param1 == 0))
          { // param1 == 0 : 4x3N
            vdi = document.documentElement.screenDisplayInfo;
            vdi.videoPlacement = 1;
            vdi.colorBackground = "black";
            vdi.viewport = "(0px,629px,479px,90px)"; // An area formed by cutting right
            and left sides of a markup document is selected. In this case, it is most preferable that
            the selected area is consistent with a "hot area".
            vdi.window = "(0px,719px,479px,0px)";
            vdi.videoviewport = "(0px,719px,479px,0px)"
          }

          if (evt.index == SCREEN_DISPLAY_MODE_CHANGE && (evt.param1 == 1))
          { // param1 == 1 : 4x3L
            vdi = document.documentElement.screenDisplayInfo;
            vdi.videoPlacement = 1;
            vdi.colorBackground = "black";
            vdi.viewport = "(0px,629px,479px,90px)";
            vdi.window = "(0px,719px,479px,0px)";
            vdi.videoviewport = "(0px,719px,479px,0px)" // Even though the entire
            DVD-video picture is selected, in a 4 x 3 letter box mode, it seems that "Matte" is added to
            the upper and lower portions of a scene.
          }
        }
      <--
    </script>
  </head>
</html>
```

```

if (evt.index == SCREEN_DISPLAY_MODE_CHANGE && (evt.param1 == 2))
{ // param1 == 2 : 4x3P
  vdi = document.documentElement.screenDisplayInfo;
  vdi.videoPlacement = 1;
  vdi.colorBackground = "black";
  vdi.viewport = "(0px,629px,479px,90px)";
  vdi.window = "(0px,719px,479px,0px)";
  vdi.videoviewport = "(0px,629px,479px,90px)" // Part of a scene formed by
cutting right and left sides of the DVD-video picture will be selected.
}

if (evt.index == SCREEN_DISPLAY_MODE_CHANGE && (evt.param1 == 3))
{ // param1 == 3 : 16x9W
  vdi = document.documentElement.screenDisplayInfo;
  vdi.videoPlacement = 1;
  vdi.colorBackground = "black";
  vdi.viewport = "(0px,719px,479px,0px)";
  vdi.window = "(0px,719px,479px,0px)";
}
}
-->
</script>

<script type="text/javascript">
<--
function setupEventHandler()
{
//eventHandler is registered to bodyNode and Interactive Contents
//SCREEN_DISPLAY_MODE_CHANGE == 500
bodyNode.addEventListener("dvdvideo",eventHandler,true);
dvdVideo.SubscribeToEvent(SCREEN_DISPLAY_MODE_CHANGE,true);}
-->
</script>
</head>

<body id="bodyNode"onload="setupEventHandler()">
.....
</body>
</html>

```

The markup document is displayed in a scene through initial static definition, and then due to the occurrence of an event according to a user's aspect ratio conversion key (or button) input, "vdi.screenDisplayMode" information is read, thereby reconstituting the aspect ratio of the scene using a script language included in the above

5     markup document.

FIG. 16 shows a flowchart of another preferred embodiment of a reproducing method according to the present invention. Referring to



FIG. 16, by using the above-mentioned static and dynamic definitions, the markup document scene is displayed according to a screen mode (aspect ratio, resolution, and video output method) set by the user or set in the reproducing apparatus. The screen mode can be changed even  
5 during reproduction through a user's input. A viewport value and a window value of the markup document applied in this case can be applied to a next markup document as it is if these are not changed in a next markup document.

In step 1601, the presentation engine 3 reads the screen mode  
10 (aspect ration, resolution, and video output method) set in the reproducing apparatus or the screen mode set by the user. Here, a video output method means that a 16 x 9 video is output in a 4 x 3 letter box or 4 x 3 pan & scan, and 16 x 9 wide mode, which can be displayed without scene distortion.

15 When a display is set to a 4 x 3 size, the AV decoder 2 converts an AV stream into a letter box or pan & scan shape and outputs the converted AV stream. When the display is set to a 16 x 9 size, the AV decoder 2 outputs the AV stream in a 16 x 9 size without conversion. This is because the AV stream is generally encoded in the 16 x 9 size in  
20 the DVD reproducing apparatus. However, it is preferable that the output is performed only when the AV stream is reproduced in a video mode other than a conventional interactive mode, and in the interactive mode, the AV stream is always output in a 16 x 9 size.

In step 1602, a default style sheet in the presentation engine 3 is  
25 selected based on the set screen mode, and properties such as viewport, window, and video viewport, which are defined in the corresponding default style sheet, are determined.

The presentation engine 3 interprets the markup document read by the reading unit 1 and checks a style sheet linked to or embedded in  
30 the markup document. In step 1603, if there is no style sheet provided by the manufacturer in the markup document, the presentation engine 3

outputs the markup document to a scene, using the properties such as viewport, window, and video viewport, which are defined in the default style sheet selected based on the set screen mode, and if there is a style sheet provided by the manufacturer in the markup document, the presentation engine 3 outputs the markup document to the scene, using the properties such as viewport, window, and video viewport, according to @screen-display, which are defined in the corresponding style sheet.

In step 1604, it is determined whether the screen mode according to a user's aspect ratio conversion key (or button) is changed. In step 1605, if the screen mode is changed by the user, the presentation engine 3 informs the corresponding markup document of an aspect ratio conversion event ASPECT\_RATIO\_CHANGE, executes a script caused by the event, interprets a screen display property variable corresponding to the changed screen mode using ScreenDisplayProperties in the presentation engine 3, changes a screen output state of the markup document based on the interpreted information, and outputs a new markup document to the scene. In step 1606, if the screen mode is not changed in step 1604, it is determined whether the output of the markup document is terminated, and the output of the markup document is terminated.

In the case of the markup document, a mode such as a letter box or pan & scan mode, has not been defined. Thus, if the markup document manufactured in a 16 x 9 size is displayed on a display for 4 x 3, the method for effectively displaying the markup document using the concept of "hot area", properties such as "viewport" and "window", has been described, so as to prevent scene distortion where contents seem to be slim in another embodiments of the above-mentioned reproducing method according to the present invention.

Hereinafter, in another embodiment of the reproducing method according to the present invention, in which using a method for most effectively synthesizing an AV scene and a markup document, which are

manufactured at a fixed aspect ratio (screen ratio) with each other without scene distortion, the user can enjoy a display state the closest to manufacturer's intention, and simultaneously, using the markup document having a fixed aspect ratio (screen ratio), a disc space can be more effectively used by avoiding repeated recording of interactive contents.

First, when a storage medium, in which AV data (DVD-video) is manufactured to a 16 x 9 size and a markup document is manufactured to a 4 x 3 size, is displayed on a display for 16 x 9 through a reproducing apparatus, displaying methods according to displaying modes (embedded mode, background mode, and PIP mode) will be described with reference to FIG. 17.

First, a case where AV data for 16 x 9, as shown in (a) of FIG. 17, is synthesized with a markup document in an "embedded mode" embedded by "object" elements, as shown in (b) of FIG. 17, will be described. If the manufacturer sets "width" and "height" of the "object" tag in the markup document so that the AV data for 16 x 9 is expressed as it is, the entire synthesized scene is selected as a viewport area and is not expanded so that there is no scene distortion in a display for 16 x 9, and an area excluding right and left blanks is selected as a window area, and the synthesized scene is displayed, thereby the scene can be effectively displayed. However, if the manufacturer sets "width" and "height" of the "object" tag used to embed the AV data for 16 x 9 to a 4 x 3 screen ratio, the AV data will be embedded in the markup document in a normal shape, letter box or pan & scan shape, and the synthesized scene will be displayed on the display for 16 x 9 without expansion. In this case, even though the AV data is manufactured to a 16 x 9 size, the AV data is embedded in the display for 16 x 9 at the 4 x 3 screen ratio, and thus this case is not considered as preferable.

Second, a case where the AV data is synthesized with the markup document in a "background" mode using the property video-placement:

in @screen-display of a cascading style sheet (CSS), as shown in (c) of FIG. 17, will be described. In the above-mentioned another embodiment of the reproducing method according to the present invention, the viewport area has both the AV data and the markup document, but the window area has been defined only in the synthesized scene thereof. Thus, if the synthesized scene in the "background" mode is displayed on the display for 16 x 9, the AV data displayed as the background is just displayed at the same 4 x 3 screen ratio as an aspect ratio of the markup document.

10 Third, a case where the AV data is synthesized with the markup document in a "PIP" mode using the property video-placement: in @screen-display of a cascading style sheet (CSS), as shown in (d) of FIG. 17, will be described. This case is similar to the shape of the embedded mode, and an original markup document will make a total scene for 4 x 3 without considering the AV data, the markup document is displayed in a scene, and then the AV data under a graphic plane will be displayed in a transparent handling area set for each PIP-# in the presentation engine. In this case, the reduced AV data under the transparent handling area appears in a predetermined area for each PIP-#, and thus adaptability is lower.

20 Since the area set to viewport: in a scene in which the markup document is synthesized with the AV data is mapped to window: for designating an area so that corresponding interactive contents are displayed on the display, in particular, in the "background" mode among various reproduction modes, the scene cannot be produced as the manufacturer wants. That is, (a) of FIG. 18 shows a case where AV data for 16 x 9 is synthesized with a markup document for 4 x 3 in a letter box shape in the "background" mode and is displayed on a display having a 16 x 9 aspect ration. In addition, (b) of FIG. 18 shows a case where the AV data for 16 x 9 is synthesized with the markup document for 4 x 3 in a pan & scan shape in the "background" mode and is

displayed on the display having the 16 x 9 aspect ratio. Since only the window area of the synthesized scene is defined when displaying the scene even though the manufacturer encodes the AV data to a 16 x 9 size, in order to prevent the AV data from displaying in the letter box or pan & scan shape, as shown in (a) and (b) of FIG. 18, in another embodiment of the present invention, a scene can be displayed in the most appropriate shape according to an aspect ratio of a display or display modes (embedded mode, background mode, and PIP mode) by defining viewport and window properties only for a markup document and viewport and window properties only for AV data, respectively.

In FIG. 19, assuming that markup documents considering different aspect ratios of displays ③ and ④ and AV data (i.e., AV contents of DVD-video format) considering different aspect ratios of displays ⑤ and ⑥ exist in displays ① and ② for 4 x 3 and 16 x 9, resolution of displays is 720 x 480 having the same pixel number, as shown in FIG. 20, in the case of NTSC. Only, in a 16 x 9 aspect ratio, the ratio of width to length of a pixel is 1.78:1, as shown in (a) of FIG. 20, and in a 4 x 3 aspect ratio, the ratio of width to length of a pixel is 1.33:1.

In this way, if a display is a television (TV), the aspect ratio of a scene pixel varies according to the type of TV, and thus it is difficult to understand variations in a scene. Thus, for the convenience of explanation, a conversion equation with regard to each case of 1.78 x 1, 1.33 x 1, and 1 x 1 screen ratios will be described with reference to FIG. 21. Only, the length of a unit pixel is the same. Namely, in all cases, there are no variations in height.

Conversion ①: The resolution of 720 x 480 having a 16 x 9 pixel aspect ratio is converted into a shape having a 1 x 1 unit pixel aspect ratio.

Total horizontal resolution

= normalization (when the length ratio of the unit pixel is 1, a width ratio, total vertical resolution)

= when the length ratio of the unit pixel is 1, a width ratio x total horizontal resolution

5 = 1.78 x 480

= 854

Therefore, the resolution of 720 x 480 having a 16 x 9 pixel aspect ratio is consistent with the resolution of 854 x 480 having a 1 x 1 unit pixel aspect ratio. That is, when converting into a ① shape, the

10 following Equation is formed:

$$X(1.78:1) = \frac{720}{854} X(1:1)$$

$$X(1:1) = \frac{854}{720} X(1.78:1)$$

Conversion ②: Conversion between the resolution of 854 x 480 and 640 x 480 having a 1 x 1 unit pixel aspect ratio

In the case of interactive contents manufactured to a 854 x 480 size, all contents cannot be displayed on a 640 x 480 display, and thus only an area (corresponding to "hot area") corresponding to 640 x 480 are selected using viewport: and displayed on the 640 x 480 display. When interactive contents manufactured to a 640 x 480 size are displayed on a 854 x 480 display, all contents are displayed in a 640 x 480 area, and the other 214 x 480 area is filled with a background color. That is, when the interactive contents of 854 x 480 are displayed on the 640 x 480 display, the viewport are of the interactive contents need to be well selected, and when the interactive contents of 640 x 480 are displayed on the 854 x 480 display, the window area of the display need to be well selected.

Conversion ③: The resolution of 720 x 480 having a 4 x 3 pixel aspect ratio is converted into a shape having a 1 x 1 unit pixel aspect ratio.

Total horizontal resolution

= normalization (when the length ratio of the unit pixel is 1, a width ratio, total vertical resolution)

5       = when the length ratio of the unit pixel is 1, a width ratio x total horizontal resolution

= 1.33 x 480

= around 640

Therefore, the resolution of 720 x 480 having a 4 x 3 pixel aspect ratio is consistent with the resolution of 640 x 480 having a 1 x 1 unit pixel aspect ratio. That is, when converting into a ③ shape, the following Equation is formed:

$$X(1.33:1) = \frac{720}{640} X(1:1)$$

$$X(1:1) = \frac{640}{720} X(1.33:1)$$

Conversion ④: Conversion between the resolution of 720 x 480 having a 16 x 9 pixel aspect ratio and the resolution of 720 x 480 having a 4 x 3 pixel aspect ratio

The following Equation is formed between the horizontal resolution having the 4 x 3 (12 x 9) pixel aspect ratio and the horizontal resolution having the 16 x 9 pixel aspect ratio.

$$X(1.78:1) = \frac{12}{16} X(1.33:1)$$

$$X(1.33:1) = \frac{16}{12} X(1.78:1)$$

20       That is, it is most appropriate that the 720 x 480 resolution in the display for 4 x 3 is displayed in 540 x 480 resolution in the display for 16 x 9, and thus when only an are (corresponding to "hot area") corresponding to 540 x 480 in the interactive contents for 16 x 9 is selected, the selected area is rightly displayed on the display for 4 x 3.

25       Meanwhile, if the 720 x 480 resolution having the 16 x 9 pixel aspect ratio is converted into a letter box shape in the 720 x 480

resolution having the 4 x 3 pixel aspect ratio, a vertical resolution is varied. Thus, the following Equation is formed between the vertical resolution having the 4 x 3 (16 x 12) pixel aspect ratio and the vertical resolution having the 16 x 9 pixel aspect ratio.

$$5 \quad Y(1.33:1) = \frac{9}{12} Y(1.78:1)$$

$$Y(1.78:1) = \frac{12}{9} Y(1.33:1)$$

That is, the size of the window area in the display for 4 x 3 should be 720 x 360 so that the 720 x 480 resolution for 16 x 9 is maintained at a 16 x 9 size and is displayed on the display for 4 x 3.

As above, when the AV data and the markup document are  
 10 manufactured by the manufacturer at one aspect ratio on the basis of conversion methods performed in a case where the ratio of a unit pixel size is different, their contents are displayed according to aspect ratios of the displays, as shown in the following table.

For reference, in the following table, the size of a pixel in each  
 15 case is set to 1 x 1 on the basis of the above-mentioned conversion relation, and thus it is assumed the resolution having the 4 x 3 aspect ratio to 640 x 480, and the resolution having the 16 x 9 aspect ratio to 854 x 480. In addition, in the embedded mode or PIP mode, it is assumed that AV data for 4 x 3 is displayed in an area of 200 x 150 and  
 20 AV data for 16 x 9 is displayed in an area of 272 x 153.

Contents manufactured	Display	Reproduction mode	Viewport size		Window size	
			Markup document	AV data	Markup Document	AV data
4 x 3 markup document, 4 x 3 AV data	4 x 3	Embedded mode	640 x 480	640 x 480	640 x 480	determined by object tag
		Background Mode	640 x 480	640 x 480	640 x 480	640 x 480



	16 x 9	PIP mode	640 x 480	640 x 480	640 x 480	200 x 150 determined by object tag
		Embedded mode	640 x 480	640 x 480	640 x 480	640 x 480
		Background mode	640 x 480	640 x 480	640 x 480	640 x 480
		PIP mode	640 x 480	640 x 480	640 x 480	200 x 150 determined by object tag
4 x 3 markup document, 16 x 9 AV data	4 x 3	Embedded Mode	640 x 480	854 x 480	640 x 480	200 x 150 determined by object tag
		Background mode	640 x 480	640 x 480 (P)	640 x 480	640 x 480
		PIP mode	640 x 480	854 x 480	640 x 480	200 x 150 determined by object tag
	16 x 9	Embedded mode	640 x 480	854 x 480	640 x 480	854 x 480
		Background mode	640 x 480	854 x 480	640 x 480	272 x 153 determined by object tag
		PIP mode	640 x 480	854 x 480	640 x 480	640 x 480
16 x 9 markup document, 4 x 3 AV data	4 x 3	Embedded mode	640 x 480	640 x 480	640 x 480	200 x 150 determined by object tag
		Background mode	640 x 480	640 x 480	640 x 480	640 x 480
		PIP mode	640 x 480	640 x 480	640 x 480	200 x 150 determined by object tag
	16 x 9	Embedded mode	854 x 480	640 x 480	854 x 480	640 x 480
		Background mode	854 x 480	640 x 480	854 x 480	200 x 150 determined by object tag
		PIP mode	640 x 480	640 x 480	854 x 480	640 x 480
16 x 9 markup document, 16 x 9 AV data	4 x 3	Embedded mode	640 x 480	854 x 480	640 x 480	200 x 150 determined by object tag
		Background mode	640 x 480	640 x 480 (P)	640 x 480	640 x 480
		PIP mode	640 x 480	854 x 480	640 x 480	200 x 150 determined by object tag
	16 x 9	Embedded mode	854 x 480	854 x 480	854 x 480	640 x 480

		Background mode	854 x 480	854 x 480	854 x 480	854 x 480
		PIP mode	854 x 480	854 x 480	854 x 480	272 x 153

In the above table, (P) indicates a pan & scan shape.

A scene in which 16 x 9 AV data is synthesized with a 4 x 3 markup document based on the above table is displayed on a display for 16 x 9 as follows: in an embedded mode, as shown in (a) of FIG. 22, the 16 x 9 AV data synthesized with a 16 x 9 markup document is displayed in the embedded mode, and in a background mode, as shown in (b) of FIG. 22, the 16 x 9 AV data synthesized with the 16 x 9 markup document is displayed in the background mode, and in a PIP mode, as shown in (c) of FIG. 22, the 16 x 9 AV data synthesized with the 16 x 9 markup document is displayed in the PIP mode.

Reproducing methods according to an aspect ratio according to a yet still another embodiment of the present invention are largely classified by a static method using a CSS and a dynamic method using an API for a DOM. When interactive contents are initially displayed in a scene, the interactive contents are displayed on a display through a static method using a default style sheet in a presentation engine or a CSS defined by a "link" tag and a "style" tag in a markup document. However, when an aspect ratio is changed by a user's input during reproduction, the aspect ratio of an output screen can be dynamically changed by adding an aspect ratio conversion function using a script language to the markup document using the API for a DOM.

Hereinafter, a static method using @screen-display rule will be described. Properties, such as viewport and window for a markup document and viewport and window for AV data, respectively, are defined in an improved @screen-display rule.

#### 1. screen-display type

4 x 3N: This case indicates that a user sets a screen output to a 4

x 3 normal shape, and this shape is a reduction shape of 16 x 9 AV data in which distortion in which a scene seems to be slim does not occur, unlike a conventional normal shape.

4 x 3L: If a user sets a screen output to a 4 x 3 letter box shape

5 4 x 3P: If a user sets a screen output to a 4 x 3 pan & scan shape

16 x 9W: If a user sets a screen output to a 16 x 9 wide shape

## 2. “video-placement” property

It designates a display mode of the AV scene. None, embedded, pip-#, and background represent nothing displayed, embedded mode, PIP mode, and background mode, respectively. An initial value is an embedded mode.

## 3. background-color property

It designates a background color of a scene formed of a single color. A value is <color>, and an initial value may vary according to a user agent (UA).

## 4. “document-viewport” property

It designates a trimming area of a markup document. A value is <shape>, and an initial value is rect (0%, 100%, 100%, 0%). Here, the value of the defined <shape> is rect(<top>,<right>,<bottom>,<left>).

## 20 5. “document-window” property

It designates an area of a window in which a markup document is displayed on a scene of a display. A value is <shape>, and an initial value is rect (0%, 100%, 100%, 0%).

## 6. “video-viewport” property

25 It designates a trimming area of the scene in which the AV scene is synthesized with the markup document scene. A value is <shape>, and an initial value is rect (0%, 100%, 100%, 0%).

## 7. “video-window” property

It designates an area of a window in which AV data is displayed

on a scene of a display. A value is <shape>, and an initial value is rect (0%, 100%, 100%, 0%).

An example of a style sheet manufactured using the type and property of @screen-display rule described above is as follows.

- 5 A default style sheet has different shapes depending on a presentation engine installed in a reproducing apparatus, and it cannot be guaranteed that a scene is displayed as the manufacturer wants. When the manufacturer wants to display the scene as one wishes, a CSS should be added to a markup document. The following default
- 10 style sheet is a default style sheet installed in a presentation engine with an assumption that AV data and a markup document stored in a storage medium are manufactured in a 16 x 9 size. Values of <shape> used in the above example are based on the above-mentioned ④ (conversion between the resolution of 720 x 480 having a 16 x 9 pixel aspect ratio
- 15 and the resolution of 720 x 480 having a 4 x 3 pixel aspect ratio).

```

@screen-display 4x3N
{
  background-color : #000000
  document-viewport : (0px,629px,479px,90px)
  document-window : (0px,719px,479px,0px)
  video-viewport : (0px,719px,479px,0px)
  video-window : (0px,719px,479px,0px)
}

@screen-display 4x3L
{
  background-color : #000000
  document-viewport : (0px,719px,479px,0px)
  document-window : (60px,719px,419px,0px)
  video-viewport : (0px,719px,479px,0px)
  video-window : (60px,719px,419px,0px)
}

@screen-display 4x3P
{
  background-color : #000000
  document-viewport : (0px,629px,479px,90px)
  document-window : (0px,719px,479px,0px)
  video-viewport : (0px,629px,479px,90px)
  video-window : (0px,719px,479px,0px)
}

```

```

@screen-display 16x9W
{
  background-color : #000000
  document-viewport : (0px,719px,479px,0px)
  document-window : (0px,719px,479px,0px)
  video-viewport : (0px,719px,479px,0px)
  video-window : (0px,719px,479px,0px)
}

```

Since the default style sheet is differently set in each reproducing apparatus, a scene cannot be usually displayed as the manufacturer wants. Thus, preferably, the manufacturer makes an additional CSS in the markup document and attaches the CSS to the document so that the AV data and the markup document can be effectively displayed even at an aspect ratio set by the user. The following example shows how the manufacturer makes the CSS in the markup document so that AV data for 16 x 9 and a markup document for 4 x 3 can be effectively displayed in a "background mode". The CSS may be made using a "style" tag, as shown the following example, and may be used through external reference using a "link" tag.

```

<!DOCTYPE html PUBLIC "-//DVD//DTD XHTML DVD-HTML 1.0//EN"
      "http://www.dvdforum.org/enav/dtd/dvdhtml-1-0.dtd">
<html>
  <head>
    <title>Example of aspect ratio change</title>
    <style type="text/css">

      @screen-display 4x3N
      {
        video-placement : background
        background-color : #000000
        document-viewport : (0px,719px,479px,0px)
        document-window : (0px,719px,479px,0px)
        video-viewport : (0px,629px,479px,90px) // If the entire area is selected using a
viewport area, AV data displayed as a background seems to be slim. Thus, in order to
solve this problem, the manufacturer just selects pan & scan. A selection area may be
varied by the manufacturer.
        video-window : (0px,719px,479px,0px)
      }

      @screen-display 4x3L
      {
        video-placement : background
        background-color : #000000
        document-viewport : (0px,719px,479px,0px)
        document-window : (60px,719px,419px,0px)
      }
    </style>
  </head>
</html>

```

```

        video-viewport : (0px,719px,479px,0px) -
        video-window : (60px,719px,419px,0px)
    }

    @screen-display 4x3P
    {
        video-placement : background
        background-color : #000000
        document-viewport : (0px,719px,479px,0px)
        document-window : (0px,719px,479px,0px)
        video-viewport : (0px,629px,479px,90px) // An area formed by cutting the right
and left sides of DVD-video will be selected.
        video-window : (0px,719px,479px,0px)
    }

    @screen-display 16x9W
    {
        video-placement : background
        background-color : #000000
        document-viewport : (0px,719px,479px,0px)
        document-window : (0px,629px,479px,90px) // In order to prevent a markup
document from distorting, a window area is reduced.
        video-viewport : (0px,719px,479px,0px)
        video-window : (0px,719px,479px,0px)
    }

    </style>
</head>
<body id="bodyNode">
.....
</body>
</html>

```

As above, the static method for displaying interactive contents according to a screen aspect ratio using the default style sheet or the CSS attached to the document by the manufacturer has been described.

5 Hereinafter, a dynamic method using an object source code of the API for the DOM will be described. The value of the object source code can be referred to using a script language in the markup document.

The following object source code is used to bind "ScreenDisplayProperties" in root elements (i.e., <frameset> and <html>)

10 of the uppermost level.

```

Interface ScreenDisplayProperties {
    attribute ScreenDisplayRule screenDisplayInfo;
};

```

Here, "ScreenDisplayProperties" are connected to root elements of a markup document, and the value of "ScreenDisplayProperties" can be referred to using a script language in the markup document.

The definition and property of an interface definition language (IDL) are as follows.

#### IDL Definition

Interface ScreenDisplayRule

```
{
  readonly attribute unsigned short screenDisplayMode;
  attribute unsigned short videoPlacement;
  attribute DOMString colorBackground;
  attribute DOMString documentviewport;
  attribute DOMString documentwindow;
  attribute DOMString videoviewport;
  attribute DOMString videowindow;
};
```

#### Attributes

**screenDisplayMode:** An aspect ratio of an output scene set by a user

```
const unsigned short SCREEN_DISPLAY_MODE_4X3NORMAL = 0;
const unsigned short SCREEN_DISPLAY_MODE_4X3LETTERBOX = 1;
const unsigned short SCREEN_DISPLAY_MODE_4X3PAN&SCAN = 2;
const unsigned short SCREEN_DISPLAY_MODE_16X9WIDE = 3;
```

**videoPlacement:** It designates a display mode of a DVD-video

```
const unsigned short VIDEO_PLACEMENT_NONE = 0;
const unsigned short VIDEO_PLACEMENT_EMBEDDED = 1;
const unsigned short VIDEO_PLACEMENT_BACKGROUND = 2;
const unsigned short VIDEO_PLACEMENT_PIP = 3;
```

**colorBackground:** It has the value of <color> as a background color of a DVD-video scene.

**documentviewport:** It has the value of <shape> as a trimming area of a markup document.

**documentwindow:** It has the value of <shape> as a window area on a display to which the trimmed markup document is to be mapped.

**videoviewport:** It has the value of <shape> as a trimming area of the DVD-video.

**videowindow:** It has the value of <shape> as a window area on a display to which the trimmed DVD-video is to be mapped. However, when videoPlacement is in an embedded mode, the window area is restricted by "width" and "height" defined by an <object> tag in the markup document.

The above-mentioned dynamic definition using the object source of the API for the DOM is implemented by a script language included in the markup document, as shown in the following example. The example is made by the manufacturer by considering event handling according to user's aspect ratio conversion of AV data for 16 x 9 (i.e., DVD-video) and a markup document for 16 x 9, which are to be displayed in an embedded mode.

```

<?xml version="1.0" encoding="UTF-8"?>
<!DOCTYPE html PUBLIC "-//DVD//DTD XHTML DVD-HTML 1.0//EN"
    "http://www.dvdforum.org/envideo/dtd/dvdhtml-1-0.dtd">
<html>
  <head>
    <title>Example of aspect ratio change</title>
    <script type="text/javascript">
      <--
        function eventHandler(evt)
        {
          var vdi;

          if (evt.index == SCREEN_DISPLAY_MODE_CHANGE && (evt.param1 == 0))
          { // param1 == 0 : 4x3N
            vdi = document.documentElement.ScreenDisplayInfo;
            vdi.videoPlacement = 1;
            vdi.colorBackground = "black";
            vdi.documentviewport = "(0px,629px,479px,90px)"; // An area formed by
            cutting right and left sides of a markup document is selected. In this case, it is most
            preferable that the selected area is consistent with a "hot area".
            vdi.documentwindow = "(0px,719px,479px,0px)";
            vdi.videoviewport = "(0px,719px,479px,0px)"
            // In an embedded state, vdi.videowindow is determined by "width" and
            "height" of an <object> tag in the markup document, and thus the manufacture sets the
            size of the window of the "object" tag so that the DVD-video is displayed in a 16 x 9 size.
          }

          if (evt.index == SCREEN_DISPLAY_MODE_CHANGE && (evt.param1 == 1))
          { // param1 == 1 : 4x3L
            vdi = document.documentElement.ScreenDisplayInfo;
            vdi.videoPlacement = 1;
            vdi.colorBackground = "black";
            vdi.documentviewport = "(0px,629px,479px,90px)";
            vdi.documentwindow = "(0px,719px,479px,0px)";
            vdi.videoviewport = "(0px,719px,479px,0px)" // Even though the entire
            DVD-video picture is selected, in a 4 x 3 letter box mode, it seems that "Matte" is added to
            the upper and lower portions of a scene.
          }

          if (evt.index == SCREEN_DISPLAY_MODE_CHANGE && (evt.param1 == 2))
          { // param1 == 2 : 4x3P
            vdi = document.documentElement.ScreenDisplayInfo;
            vdi.videoPlacement = 1;

```



```

        vdi.colorBackground = "black";
        vdi.documentviewport = "(0px,629px,479px,90px)";
        vdi.documentwindow = "(0px,719px,479px,0px)";
        vdi.videoviewport = "(0px,629px,479px,90px)" // Part of a scene formed by
        cutting right and left sides of the DVD-video picture will be selected.
    }

    if (evt.index == SCREEN_DISPLAY_MODE_CHANGE && (evt.param1 == 3))
    { // param1 == 3 : 16x9W
        vdi = document.documentElement.ScreenDisplayInfo;
        vdi.videoPlacement = 1;
        vdi.colorBackground = "black";
        vdi.documentviewport = "(0px,719px,479px,0px)";
        vdi.documentwindow = "(0px,719px,479px,0px)";
        vdi.videoviewport = "(0px,719px,479px,0px)"
    }
}
-->
</script>

<script type="text/javascript">
<--
    function setupEventHandler()
    {
        // eventHandler is registered to bodyNode and Interactive Contents
        // SCREEN_DISPLAY_MODE_CHANGE == 500
        bodyNode.addEventListener("dvdvideo",eventHandler,true);
        dvdVideo.SubscribeToEvent(SCREEN_DISPLAY_MODE_CHANGE,true);}
-->
</script>
</head>

<body id="bodyNode" onload="setupEventHandler()">
.....
</body>
</html>

```

The markup document is displayed in a scene through initial static definition, and then due to the occurrence of an event according to a user's aspect ratio conversion key (or button) input, "vdi.screenDisplayMode" information is read, thereby reconstituting the aspect ratio of the scene using a script language included in the above

5

markup document.

FIG. 23 shows a flowchart of another preferred embodiment of a reproducing method according to the present invention. Referring to

10

FIG. 23, by using the above-mentioned static and dynamic definitions,

the markup document scene is displayed according to a screen mode (aspect ratio, resolution, and video output method) set by the user or set in the reproducing apparatus. The screen mode can be changed even during reproduction through a user's input. Values of viewport and window of the markup document and the AV data applied in this case can be applied to a next markup document as it is if these are not changed in a next markup document.

In step 2301, the presentation engine 3 reads the screen mode (aspect ration, resolution, and video output method) set in the reproducing apparatus or the screen mode set by the user: Here, a video output method means that a 16 x 9 video is output in a 4 x 3 letter box or 4 x 3 pan & scan, and 16 x 9 wide mode, which can be displayed without scene distortion.

In this case, even though a display is set to a 4 x 3 size, in an embedded mode or PIP mode, the AV decoder 2 does not output an AV stream in a letter box or pan & scan shape but outputs an AV stream for 16 x 9, as if the display is set to a 16 x 9 size, without conversion. This is because the AV stream is generally encoded in the 16 x 9 size in the DVD reproducing apparatus.

In step 2302, a default style sheet in the presentation engine 3 is selected based on the set screen mode, and properties such as document viewport, document window, video viewport, and video window, which are defined in the corresponding default style sheet, are determined.

The presentation engine 3 interprets the markup document read by the reading unit 1 and checks a style sheet linked to or embedded in the markup document. In step 2303, if there is no style sheet provided by the manufacturer in the markup document, the presentation engine 3 outputs the markup document to a scene, using the properties such as document viewport, document window, video viewport, and video window, which are defined in the default style sheet selected based on the set

screen mode, and if there is a style sheet provided by the manufacturer in the markup document, the presentation engine 3 outputs the markup document to the scene, using the properties such as document viewport, document window, video viewport, and video window, according to  
5 @screen-display, which are defined in the corresponding style sheet.

In step 2304, it is determined whether the screen mode according to a user's aspect ratio conversion key (or button) is changed. In step 2305, if the screen mode is changed by the user, the presentation engine 3 informs the corresponding markup document of an aspect ratio  
10 conversion event ASPECT\_RATIO\_CHANGE, executes a script caused by the event, interprets a screen display property variable corresponding to the changed screen mode using ScreenDisplayProperties in the presentation engine 3, changes a screen output state of the markup document based on the interpreted information, and outputs a new  
15 markup document to the scene. In step 2306, if the screen mode is not changed in step 2304, it is determined whether the output of the markup document is terminated, and the output of the markup document is terminated.

The above recording and reproducing methods can be  
20 implemented with a computer program. Program codes and code segments of the computer program can be easily made by a computer programmer skilled in the art. Also, the above program is stored in information storage media (computer readable media), read and executed by the computer, thereby performing a method for recording  
25 and reproducing a markup document and AV data. The information storage media include magnetic recording media, optical recording media, and carrier waves.

#### Industrial Applicability

30 As described above, according to the present invention, an information storage medium including AV data and a markup document

so that the AV data and the markup document can be displayed in various ways in an interactive mode in response to resolution and aspect ratio (screen ratio), a recording method, a reproducing method, and a reproducing apparatus therefor are provided. As such, the user can  
5 enjoy a fine display scene. Further, a contents manufacturer and a recording and reproducing apparatus manufacturer can increase/reduce the markup document scene using the window and viewport properties, thereby sparing an available memory space and providing a special function such as scroll. In addition, part of the AV scene can be  
10 increased or reduced using the property video-viewport, and interactive contents manufactured at one fixed screen ratio can be changed into various screen ratios, using the viewport and window properties for interactive contents.

According to the present invention, when the interactive contents  
15 manufactured at the fixed screen ratio are reproduced by the reproducing apparatus using the markup language, the interactive contents can be effectively displayed without a portion from which important information is subtracted, regardless of the screen ratio of the display, thereby simplifying an authoring process, avoiding contents  
20 overlapping and more effectively using a disc space.

In addition, the AV data and the markup document manufactured at the fixed aspect ratio can be effectively displayed on the display having various aspect ratios through a static method using a CSS related to an aspect ratio and a dynamic method using a script language  
25 in the markup document using an API for a DOM. Thus, the user can enjoy a display state the closest to manufacturer's intention, and the manufacturer can more effectively use the storage medium by avoiding interactive contents overlapping.

While this invention has been particularly shown and described  
30 with reference to preferred embodiments thereof, it will be understood by those skilled in the art that various changes in form and details may be

made therein without departing from the spirit and scope of the invention as defined by the appended claims.

What is claimed is:

1. An information storage medium comprising:  
AV data including audio data and video data;  
a markup document; and  
5 scene synthesis information which describes one of at least two display modes for displaying a markup document scene obtained from the markup document and an AV scene obtained from the AV data together.
- 10 2. The medium of claim 1, wherein the display modes include an embedded mode in which the AV scene is embedded in at least part of the markup document scene and is displayed.
- 15 3. The medium of claim 1, wherein the display modes include a picture in picture (PIP) mode in which the AV scene is overlapped on the markup document scene.
- 20 4. The medium of claim 1, wherein the display modes include a background mode in which the AV scene and the markup document scene are overlapped on each other and displayed.
- 25 5. The medium of claim 4, wherein the display modes include a background mode in which the markup document scene is overlapped on the AV scene and displayed.
- 30 6. The medium of claim 1, wherein the scene synthesis information includes a style sheet linked to or embedded in the markup document.
7. The medium of claim 1, wherein the scene synthesis

information includes a link tag recorded in the markup document, and a cascading style sheet (CSS) inserted in the link tag.

8. The medium of claim 7, wherein the CSS includes display mode designation information for designating a display mode of the AV scene.

9. The medium of claim 8, wherein the CSS further includes an AV trimming area designation information for designating an area to increase and reduce a desired portion of the AV scene.

10. The medium of claim 8, wherein the CSS further includes background color designation information for designating a background color of the AV scene.

15

11. The medium of claim 8, wherein the CSS further includes trimming area designation information for designating a trimming area of a scene in which the AV scene is synthesized with the markup document.

20

12. The medium of claim 8, wherein the CSS further includes window designation information for designating a window in which a scene where the AV scene is synthesized with the markup document is displayed on the screen of a display.

25

13. The medium of claim 8, wherein the CSS further includes screen display type information representing an aspect ratio of a scene in which the AV scene is synthesized with the markup document scene.

30

14. The medium of claim 8, wherein the CSS further includes window designation information of the AV scene for designating an area

of a window in which a trimmed AV scene is displayed on the screen of the display.

15. The medium of claim 7, wherein the scene synthesis  
5 information further includes an object having property variables for controlling the CSS and a program for controlling the CSS on the basis of the object.

16. The medium of claim 15, wherein the property variables  
10 include property variables for designating a display mode of the AV scene.

17. The medium of claim 16, wherein the property variables  
15 further include a property variable for designating an area to increase and reduce a desired portion of the AV scene.

18. The medium of claim 16, wherein the property variables  
20 further include a property variable for designating a background color of the AV scene.

19. The medium of claim 16, wherein the property variables  
25 further include a property variable for designating a window in which a scene where the AV scene is synthesized with the markup document is displayed on the screen of the display.

20. The medium of claim 16, wherein the property variables  
30 further include a property variable for designating a trimming area in which a scene where the AV scene is synthesized with the markup document is displayed on the screen of the display.

21. The medium of claim 16, wherein the property variables



further include a screen display mode representing an aspect ratio of a scene in which the AV scene is synthesized with the markup document scene.

5           22. The medium of claim 16, wherein the property variables further include a property variable for designating a window in which a scene where the AV scene is synthesized with the markup document is displayed on the screen of the display.

10           23. The medium of claim 1, further comprising reproduction control information for the AV data, and the AV data is decoded as the AV scene by referring to the reproduction control information.

15           24. The medium of claim 1, wherein the AV data and the reproduction control information are recorded in a video directory, and the markup document and the scene synthesis information are recorded in an interactive directory.

20           25. An information storage medium comprising:  
AV data including audio data and video data;  
a markup document; and  
scene synthesis information in which a markup document scene obtained from the markup document is synthesized with an AV scene obtained from the AV data without scene distortion corresponding the  
25 change of a screen mode.

30           26. The medium of claim 25, wherein the screen synthesis information is stored in a cascading style sheet (CSS) file linked to the markup document using a link tag or embedded in the markup document using a style tag.

27. The medium of claim 26, wherein the screen synthesis information includes at least one of screen display type information for designating an aspect ratio of a scene in which the AV scene is synthesized with the markup document scene, display mode designation information for designating a display mode of the AV scene, background color designation information for designating a background color of the scene, trimming area designation information of a trimming area of a scene in which the AV scene is synthesized with the markup document scene, window designation information for designating a window in which the synthesized scene is displayed on a screen of a display, and AV trimming area designation information for designating an area to increase and reduce a desired portion of the AV scene.

28. The medium of claim 27, wherein the display mode designation information indicates at least one of an embedded mode in which at least the AV scene is embedded in at least part of the markup document scene, a picture in picture (PIP) mode in which the AV scene is overlapped on the markup document scene, and a background mode in which the markup document scene is overlapped on the AV scene.

29. The medium of claim 28, wherein the scene synthesis information is set so that in the embedded mode of the interactive mode or PIP mode, when the AV data having a first aspect ratio is displayed on a display having a second aspect ratio having a resolution lower than that of the first aspect ratio, the AV data is output at the first aspect ratio, and in the background mode of the interactive mode or video mode, the AV data is output in a pan & scan or letterbox shape.

30. The medium of claim 27, wherein in the markup document, contents which should be displayed, are recorded in a maximum area shown regardless of an aspect ratio of the display, that is, a hot area,

and unimportant contents are recorded or any contents are not recorded in other area.

31. The medium of claim 30, wherein when the markup  
5 document having a first aspect ratio is displayed on a display having a second aspect ratio having a resolution lower than that of the first aspect ratio, the hot area is selected using the trimming area designation information of the synthesized scene, and the selected hot area is mapped to a designated area on the screen of the display using the  
10 window designation information of the synthesized scene.

32. The medium of claim 26, wherein the screen synthesis information includes at least one of screen display type information for designating an aspect ratio of a scene in which the AV scene is synthesized with the markup document scene, display mode designation  
15 information for designating a display mode of the AV scene, background color designation information for designating a background color of the scene, markup document trimming area designation information for designating a trimming area of the markup document, markup document window designation information for designating a window in which the  
20 markup document scene is displayed on a screen of a display, AV trimming area designation information for designating an area to increase and reduce a desired portion of the AV scene, and window area designation information of the AV scene for designating a window in  
25 which only the AV scene is displayed on the screen of the display.

33. The medium of claim 32, wherein when the AV data having a first aspect ratio is displayed on a display having a second aspect ratio having a resolution lower than that of the first aspect ratio, the scene  
30 synthesis information is set so that the AV data having the first aspect ratio is output without conversion.

34. The medium of claim 26, wherein the scene synthesis information further includes an object having property variables for controlling the CSS and a program for controlling the CSS on the basis of the object.

5

35. The medium of claim 34, wherein the property variables include at least one of a screen display mode for designating an aspect ratio of a scene in which the AV scene is synthesized with the markup document scene, a property for designating a background color of the scene, a property for designating a trimming area of a scene in which the AV scene is synthesized with the markup document scene, a property for designating a window in which the synthesized scene is displayed on the screen of the display, and a property for designating a trimming area to increase and reduce a desired portion of the AV scene.

10  
15

36. The medium of claim 35, wherein in response to user's screen mode conversion, the program using an object source controls a property for designating a trimming area of the synthesized scene, a property for designating a window area of the synthesized scene, and a property for designating a trimming area of the AV scene according to the screen display mode including an aspect ratio, a screen ratio, and a video output mode, thereby reconstituting the aspect ratio of the scene.

20

37. The medium of claim 35, wherein the property variables include at least one of a screen display mode for designating an aspect ratio of a scene in which the AV scene is synthesized with the markup document scene, a property for designating a display mode of the AV scene, a property for designating a background color of the scene, a property for designating a trimming area of the markup document scene, a property for designating a window in which the markup document scene is displayed on the screen of the display, a property for

25  
30

designating a trimming area to increase and reduce a desired portion of the AV scene, a property for designating a window in which the AV scene is displayed on the screen of the display.

5           38. The medium of claim 37, wherein in response to user's screen mode conversion, the program using an object source controls a property for designating a trimming area of the synthesized scene, a property for designating a window area of the markup document scene, a property for designating a trimming area of the AV scene, and a property  
10 for designating a window area of the AV scene according to the screen display mode, thereby reconstituting the aspect ratio of the scene.

          39. The medium of claim 25, wherein conversion between a screen ratio and an aspect ratio according to the screen mode includes  
15 conversion of a 720 x 480 resolution having a 16 x 9 pixel aspect ratio into a 1 x 1 unit pixel aspect ratio, conversion between a 854 x 480 resolution and 640 x 480 resolution each having a 1 x 1 unit pixel aspect ratio, conversion of a 720 x 480 resolution having a 4 x 3 pixel aspect ratio into a 1 x 1 unit pixel aspect ratio, conversion of a 720 x 480  
20 resolution having a 4 x 3 pixel aspect ratio into a 1 x 1 unit pixel aspect ratio, and conversion between a 720 x 480 resolution having a 16 x 9 pixel aspect ratio and a 720 x 480 resolution having a 4 x 3 pixel aspect ratio.

25           40. The medium of claim 27, wherein the screen display type information includes 4 x 3 normal, 4 x 3 letterbox, 4 x 3 pan & scan, and 16 x 9 wide.

          41. A method for recording AV data including audio data and  
30 video data on an information storage medium, the method comprising:  
          (a) recording the AV data;

(b) recording a markup document to be displayed together with the AV data; and

(c) recording scene synthesis information which describes one of at least two display modes for displaying a markup document scene  
5 obtained from the markup document and an AV scene obtained from the AV data together.

42. The method of claim 41, wherein step (c) includes recording a style sheet file linked to or embedded in the markup document.

10

43. The method of claim 41, wherein step (c) includes recording a cascading style sheet (CSS) file linked to or embedded in the markup document.

15

44. The method of claim 43, wherein in step (a), the AV data is recorded in a video directory, in step (b), the markup document is recorded in an interactive directory, and in step (c), the scene synthesis information is recorded in the interactive directory.

20

45. The method of claim 43, wherein the screen synthesis information includes at least one of screen display type information for designating an aspect ratio of a scene in which the AV scene is synthesized with the markup document scene, display mode designation information for designating a display mode of the AV scene, background  
25 color designation information for designating a background color of the scene, trimming area designation information of a trimming area of a scene in which the AV scene is synthesized with the markup document scene, window designation information for designating a window in which the synthesized scene is displayed on a screen of a display, and  
30 AV trimming area designation information for designating an area to increase and reduce a desired portion of the AV scene.

46. The method of claim 45, wherein the display mode designation information indicates at least one of an embedded mode in which at least the AV scene is embedded in at least part of the markup document scene, a picture in picture (PIP) mode in which the AV scene is overlapped on the markup document scene, and a background mode in which the markup document scene is overlapped on the AV scene.

47. The method of claim 45, wherein in step (b), contents which should be displayed, are recorded in a maximum area shown regardless of an aspect ratio of the display, that is, a hot area, and unimportant contents are recorded or any contents are not recorded in the other area.

48. The method of claim 47, wherein when the markup document having a first aspect ratio is displayed on a display having a second aspect ratio having a resolution lower than that of the first aspect ratio, the hot area is selected using the trimming area designation information of the synthesized scene, and the selected hot area is mapped to a designated area on the screen of the display using the window designation information of the synthesized scene.

20

49. The method of claim 45, wherein the scene synthesis information further includes window designation information of the AV scene for designating a window in which the AV scene is displayed on the scene of the display.

25

50. The method of claim 43, wherein in step (c), an object having property variables for controlling the CSS and a program for controlling the CSS on the basis of the object are recorded.

51. The method of claim 50, wherein the property variables include at least one of a screen display mode for designating an aspect ratio of a scene in which the AV scene is synthesized with the markup

30

document scene, a property for designating a display mode of the AV scene, a property for designating a background color of the scene, a property for designating a trimming area of a scene in which the AV scene is synthesized with the markup document scene, a property for designating a window in which the synthesized scene is displayed on the screen of the display, and a property for designating a trimming area to increase and reduce a desired portion of the AV scene.

52. The method of claim 51, wherein in response to user's screen mode conversion, the program using an object source controls a property for designating a trimming area of the synthesized scene, a property for designating a window area of the synthesized scene, and a property for designating a trimming area of the AV scene according to the screen display mode, thereby reconstituting the aspect ratio of the scene.

53. The method of claim 50, wherein the property variables include at least one of a screen display mode for designating an aspect ratio of a scene in which the AV scene is synthesized with the markup document scene, a property for designating a display mode of the AV scene, a property for designating a background color of the scene, a property for designating a trimming area of the markup document scene, a property for designating a window in which the markup document scene is displayed on the screen of the display, a property for designating a trimming area to increase and reduce a desired portion of the AV scene, a property for designating a window in which the AV scene is displayed on the screen of the display.

54. The method of claim 53, wherein in response to user's screen mode conversion, the program using an object source controls a property for designating a trimming area of the markup document scene,



a property for designating a window area of the markup document scene,  
a property for designating a trimming area of the AV scene, and a  
property for designating a window of the AV scene area according to the  
screen display mode, thereby reconstituting the aspect ratio of the  
5 scene.

55. A method for reproducing AV data including audio data and  
video data recorded on an information storage medium, the method  
comprising:

10 (a) interpreting a markup document to be displayed together  
with the AV data;

(b) interpreting scene synthesis information which describes  
at least two display modes for displaying a markup document scene  
obtained by reproducing the markup document and an AV scene  
15 obtained by reproducing the AV data together; and

(c) displaying the AV scene and the markup document scene in  
one of the display modes according to the interpreted scene synthesis  
information.

20 56. The method of claim 55, wherein step (c) includes displaying  
by embedding the AV scene in at least part of the markup document  
scene.

25 57. The method of claim 55, wherein step (c) includes displaying  
by using a picture in picture (PIP) technique for overlapping the AV  
scene on the markup document scene.

58. The method of claim 55, wherein step (c) includes displaying  
by overlapping the AV scene and the markup document scene.

30

59. The method of claim 55, wherein step (b) includes

interpreting a style sheet file linked to or embedded in the markup document.

60. The method of claim 59, wherein step (b) comprises:

5 (b11) interpreting a link tag in which information referred to is recorded, so as to call a cascading style sheet (CSS) file and calling the CSS file; and

(b12) interpreting the called CSS file.

10 61. The method of claim 60, wherein step (b12) includes reading display mode designation information for designating a display mode of the AV scene and trimming area designation information for designating an area to increase and reduce a desired portion of the AV scene.

15

62. The method of claim 61, wherein step (b12) includes further reading screen display type information representing an aspect ratio of a scene in which the AV scene is synthesized with the markup document scene, background color designation information for designating a background color of the scene, trimming area designation information of a trimming area of the scene in which the AV scene is synthesized with the markup document scene, and window designation information for designating a window in which the synthesized scene is displayed on a screen of a display.

25

63. The method of claim 60, wherein step (b12) further includes reading screen display type information representing an aspect ratio of a scene in which the AV scene is synthesized with the markup document scene, background color designation information for designating a background color of the scene, markup document trimming area designation information for designating a trimming area of the markup

30

document scene, markup document window designation information for designating a window in which the markup document is displayed on a screen of a display, AV trimming area designation information for designating an area to increase and reduce a desired portion of the AV scene, and AV scene window designation information for designating a window in which the AV scene is displayed on the screen of the display.

64. The method of claim 61, wherein step (b) further includes interpreting a program being coded on the basis of an object having property variables for controlling the CSS and for controlling the CSS.

65. The method of claim 64, wherein step (b13) further includes increasing/reducing an output AV scene by controlling a property for designating a display mode of the AV scene and a property for designating a trimming area of the AV scene to increase and reduce a desired portion of the AV scene according to a user's input by the program using an object source.

66. The method of claim 64, wherein step (b13) further controlling a property for designating a trimming area of the synthesized scene, a property for designating a window area of the synthesized scene, and a property for designating a trimming area of the AV scene according to the screen display mode by the program using an object source in response to user's screen mode conversion, thereby reconstituting the aspect ratio of the scene.

67. The method of claim 64, wherein step (b13) further includes controlling a property for designating a trimming area of the markup document scene, a property for designating a window area of the markup document scene, a property for designating a trimming area of the AV scene, and a property for designating a window area of the AV scene

according to the screen display mode by the program using an object source in response to user's screen mode conversion, thereby reconstituting the aspect ratio of the scene.

5           68. A method for reproducing AV data including audio data and video data having a predetermined aspect ratio recorded on an information storage medium and a markup document having a predetermined aspect ratio and displaying the AV data and the markup document, the method comprising:

10           (a) reading scene synthesis information corresponding to a scene mode set in a reproducing apparatus or set by a user; and

              (b) interpreting the read scene synthesis information, displaying an AV scene obtained by reproducing the AV data and a markup document scene obtained by reproducing the markup document to be  
15 displayed together with the AV data, and changing the output state of the markup document scene in response to scene mode change.

              69. The method of claim 68, wherein step (b) comprises:

20           (b1) selecting a default style sheet in the reproducing apparatus on the basis of a set scene mode;

              (b2) reading scene synthesis information defined in the selected default style sheet including trimming area designation information for designating a trimming area of the AV scene and the markup document scene, window designation information for designating a window in  
25 which the synthesized scene is displayed on the screen of a display, and AV trimming area designation information for designating an area to increase and reduce a desired portion of the AV scene; and

              (b3) checking a style sheet linked to or embedded in the markup document, displaying the markup document using the scene synthesis  
30 information in the default style sheet if there is no style sheet in the markup document, and displaying the markup document using the scene

synthesis information defined in a corresponding style sheet if there is a style sheet in the markup document.

70. The method of claim 69, wherein step (b3) comprises:  
5 (b31) determining whether a scene mode is changed by the user;  
(b32) if the scene mode is changed, transmitting scene mode change control information to the markup document and executing a script therefrom; and  
(b33) changing the output state of the markup document scene in  
10 response to scene mode change using screen display properties.

71. The method of claim 70, wherein step (b33) includes  
in an embedded mode of an interactive mode or a PIP mode, outputting the AV data at a first aspect ratio when the AV data having the first  
15 aspect ratio is displayed on a display having a second aspect ratio having a resolution lower than that of the first aspect ratio, and in a background mode of the interactive mode or video mode, outputting the AV data in a pan & scan or letterbox shape.

20 72. The method of claim 69, wherein step (b) comprises:  
(b1) selecting a default style sheet in the reproducing apparatus on the basis of a set scene mode;  
(b2) reading scene synthesis information defined in the selected default style sheet including markup document window designation  
25 information for designating a window in which the markup document scene is displayed on the screen of the display, markup document trimming area designation information for designating a trimming area of the markup document scene, AV trimming area designation information for designating an area to increase and reduce a desired portion of the  
30 AV scene, and AV window area designation information for designating a

window in which the AV scene is displayed on the screen of the display;  
and

(b3) checking a style sheet linked to or embedded in the markup document, displaying the markup document using the scene synthesis information in the default style sheet if there is no style sheet in the markup document, and displaying the markup document using the scene synthesis information defined in a corresponding style sheet if there is a style sheet in the markup document.

10           73. The method of claim 72, wherein step (b3) comprises:  
              (b31) determining whether a scene mode is changed by the user;  
              (b32) if the scene mode is changed, transmitting scene mode change control information to the markup document and executing a script therefrom; and  
15           (b33) changing the output state of the markup document scene in response to scene mode change using screen display properties.

              74. The method of claim 73, wherein step (b33) includes  
outputting the AV data having a first aspect ratio without conversion  
20 using trimming area designation information and window area designation information of the markup document scene and trimming area designation information and window area designation information of the AV scene, which are defined respectively, when the AV data having the first aspect ratio is displayed on a display having a second aspect  
25 ratio having a resolution lower than that of the first aspect ratio.

              75. An apparatus for reproducing AV data including audio data and video data recorded on an information storage medium, the apparatus comprising:  
30           a reading unit which reads the AV data and a markup document to be displayed together with the AV data;

a decoder which decodes the AV data read by the reading unit and outputs an AV scene; and

a controller which interprets the markup document read by the reading unit, outputs a markup document scene, interprets scene  
5 synthesis information which describes at least two display modes for displaying the markup document scene together the AV scene, and displays the AV scene and the markup document scene in one of the display modes according to the interpreted scene synthesis information.

10 76. The apparatus of claim 75, wherein the scene synthesis information includes at least one of display mode designation information for designating a display mode of the AV scene, background color designation information for designating a background color of the scene, trimming area designation information for designating a trimming  
15 area of a scene in which the AV scene is synthesized with the markup document scene, window designation information for designating a window in which the synthesized scene is displayed on a screen of a display, and AV trimming area designation information for designating an area to increase and reduce a desired portion of the AV scene.

20 77. The apparatus of claim 76, wherein the display mode designation information indicates at least one of an embedded mode in which at least the AV scene is embedded in at least part of the markup document scene, a picture in picture (PIP) mode in which the AV scene  
25 is overlapped on the markup document scene, and a background mode in which the markup document scene is overlapped on the AV scene.

78. The apparatus of claim 75, wherein the controller interprets a cascading style sheet (CSS) linked to or embedded in the markup  
30 document and interprets a program being coded on the basis of property variables for controlling the CSS and for controlling the CSS.

79. The apparatus of claim 78, wherein the controller controls a property for designating a display mode of the AV scene and a property for designating a trimming area of the AV scene to increase and reduce a desired portion of the AV scene by a program using an embedded object source according to a user's input and increases/reduces an output AV scene.

80. The apparatus of claim 75, further comprising a blender which displays the AV scene and the markup document scene together by a display command according to the scene synthesis information interpreted by the controller.

81. An apparatus for reproducing AV data including audio data and video data recorded on an information storage medium, the apparatus comprising:

a reading unit which reads the AV data and a markup document to be displayed together with the AV data;

a decoder which decodes the AV data read by the reading unit and outputs an AV scene; and

a controller which interprets scene synthesis information corresponding to a scene mode set in a reproducing apparatus or set by a user, interprets the markup document to be displayed together with the AV data read by the reading unit using the interpreted scene synthesis information, displays a markup document scene, and changes the output state of the markup document scene in response to scene mode change.

82. The apparatus of claim 81, wherein the scene synthesis information includes at least one of screen display type information for designating an aspect ratio of a scene in which the AV scene is synthesized with the markup document scene, display mode designation information for designating a display mode of the AV scene, background



color designation information for designating a background color of the scene, trimming area designation information for designating a trimming area of a scene in which the AV scene is synthesized with the markup document scene, window designation information for designating a window in which the synthesized scene is displayed on a screen of a display, and AV trimming area designation information for designating an area to increase and reduce a desired portion of the AV scene.

83. The apparatus of claim 82, wherein the display mode designation information indicates at least one of an embedded mode in which at least the AV scene is embedded in at least part of the markup document scene, a picture in picture (PIP) mode in which the AV scene is overlapped on the markup document scene, and a background mode in which the markup document scene is overlapped on the AV scene.

15

84. The apparatus of claim 83, wherein the controller interprets a cascading style sheet (CSS) linked to or embedded in the markup document and interprets a program being coded on the basis of property variables for controlling the CSS and for controlling the CSS.

20

85. The apparatus of claim 84, wherein the controller controls a property for designating a trimming area of the synthesized scene, a property for designating a window area of the synthesized scene, and a property for designating a trimming area of the AV scene in the style sheet file interpreted according to a screen display property, by the program using an object source in response to user's scene mode change.

25

86. The apparatus of claim 83, wherein the controller controls that in an embedded mode of an interactive mode or a PIP mode, when the AV data having a first aspect ratio is displayed on a display having a

30

second aspect ratio having a resolution lower than that of the first aspect ratio, the AV data is output by the decoder at the first aspect ratio, and in a background mode of the interactive mode or video mode, the AV data is output by the decoder in a pan & scan or letterbox shape.

5

87. The apparatus of claim 84, wherein the scene synthesis information includes at least one of at least one of screen display type information for designating an aspect ratio of a scene in which the AV scene is synthesized with the markup document scene, display mode designation information for designating a display mode of the AV scene, background color designation information for designating a background color of the scene, markup document trimming area designation information for designating a trimming area of the markup document, markup document window designation information for designating a window in which the markup document scene is displayed on a screen of a display, AV trimming area designation information for designating an area to increase and reduce a desired portion of the AV scene, and window area designation information of the AV scene for designating a window in which the AV scene is displayed on the screen of the display.

20

88. The apparatus of claim 87, wherein the controller controls a property for designating a trimming area of the markup document scene, a property for designating a window area of the markup document scene, a property for designating a trimming area of the AV scene, and a property for designating a window area of the AV scene in the style sheet file interpreted according to a screen display property, by the program using an object source in response to user's scene mode change, thereby reconstituting an aspect ratio of the scene.

30

89. The apparatus of claim 88, wherein the AV data having a first aspect ratio is output by the decoder without conversion using

trimming area designation information and window area designation  
information of the markup document scene and trimming area  
designation information and window area designation information of the  
AV scene, which are respectively defined, when the AV data having the  
5 first aspect ratio is displayed on a display having a second aspect ratio  
having a resolution lower than that of the first aspect ratio.

90. The apparatus of claim 81, further comprising a blender  
which displays the AV scene and the markup document scene together  
10 by a display command according to the scene synthesis information  
interpreted by the controller.

15

20

25

30

FIG. 1

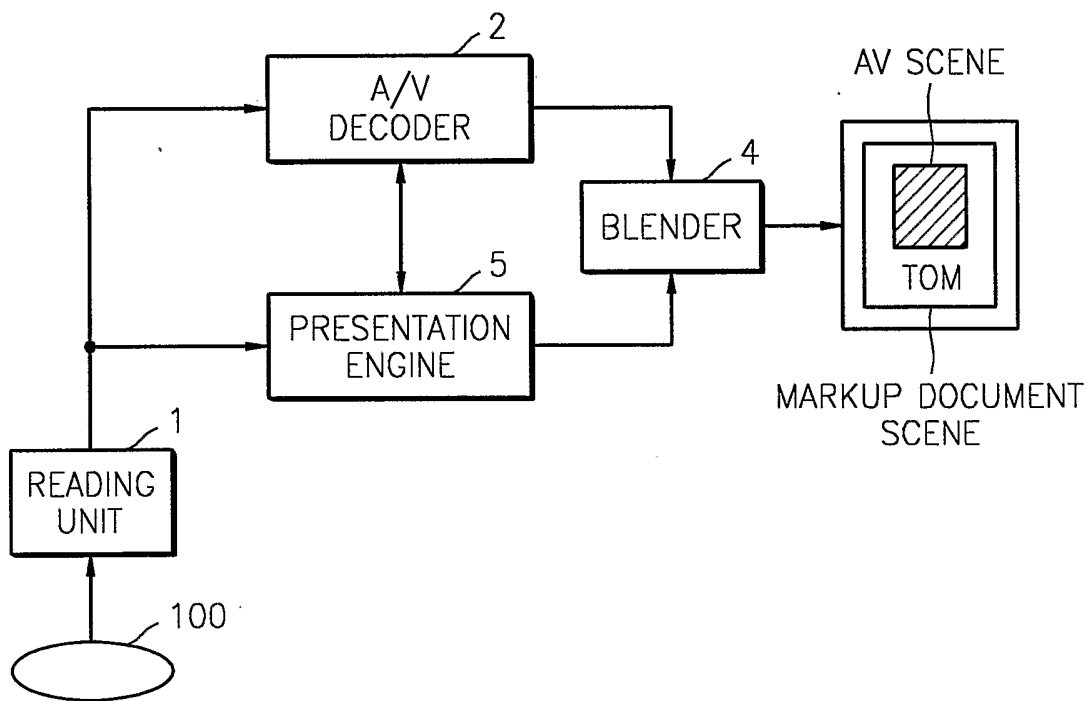
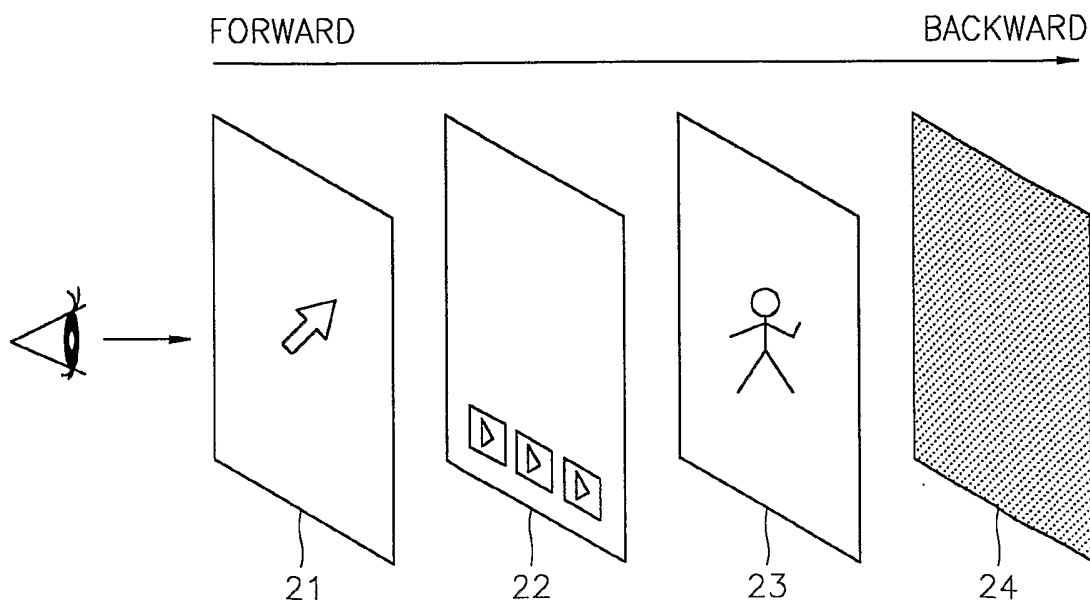
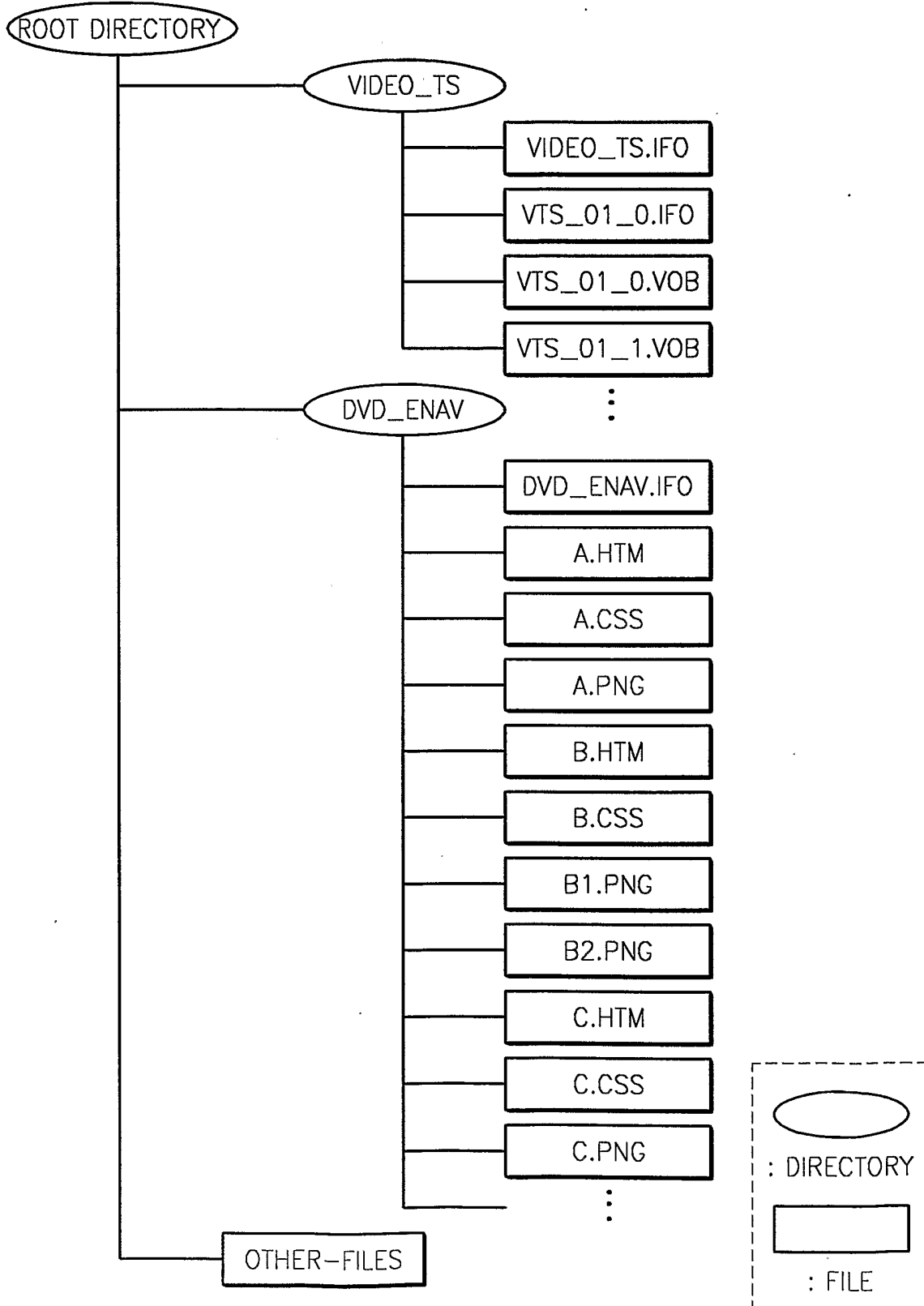

FIG. 2



2/20  
**FIG. 3**



3/20  
FIG. 4



FIG. 5

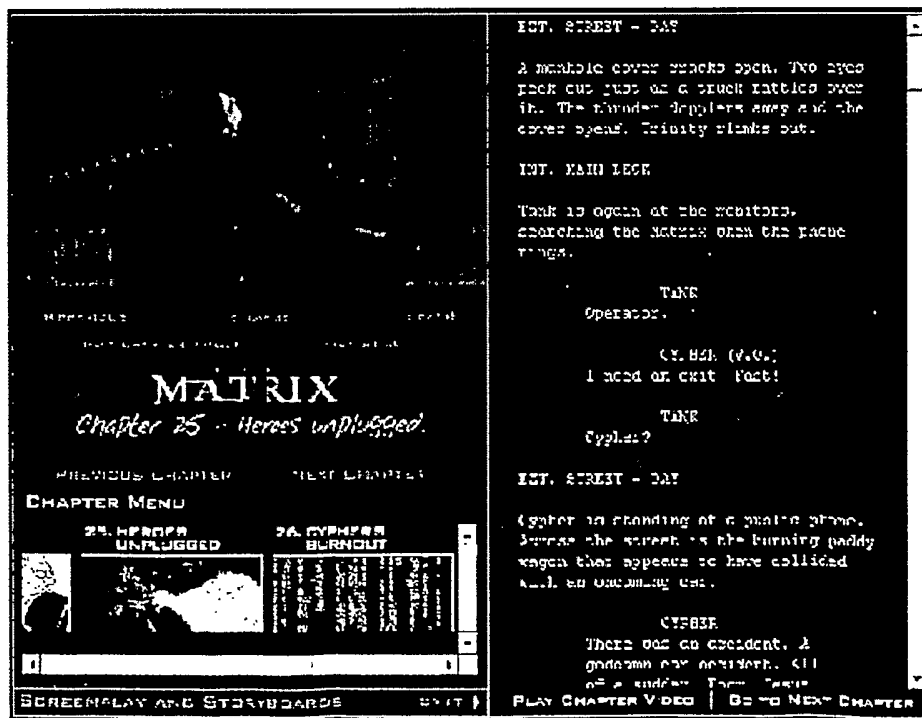

4/20

FIG. 6



5/20  
**FIG. 7**

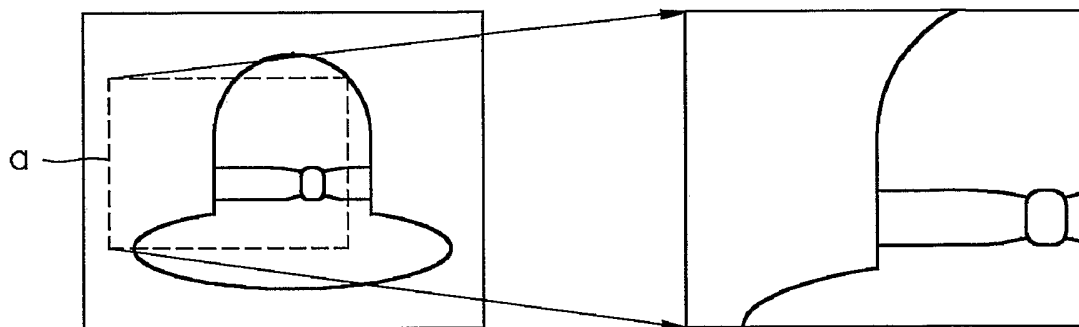

AV SCENE

BACKGROUND MODE

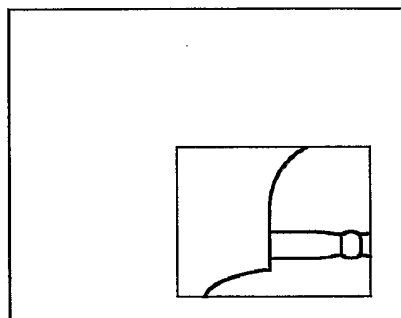

PIP MODE

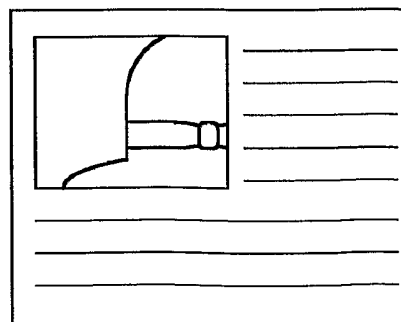

EMBEDDED MODE



6/20

FIG. 8

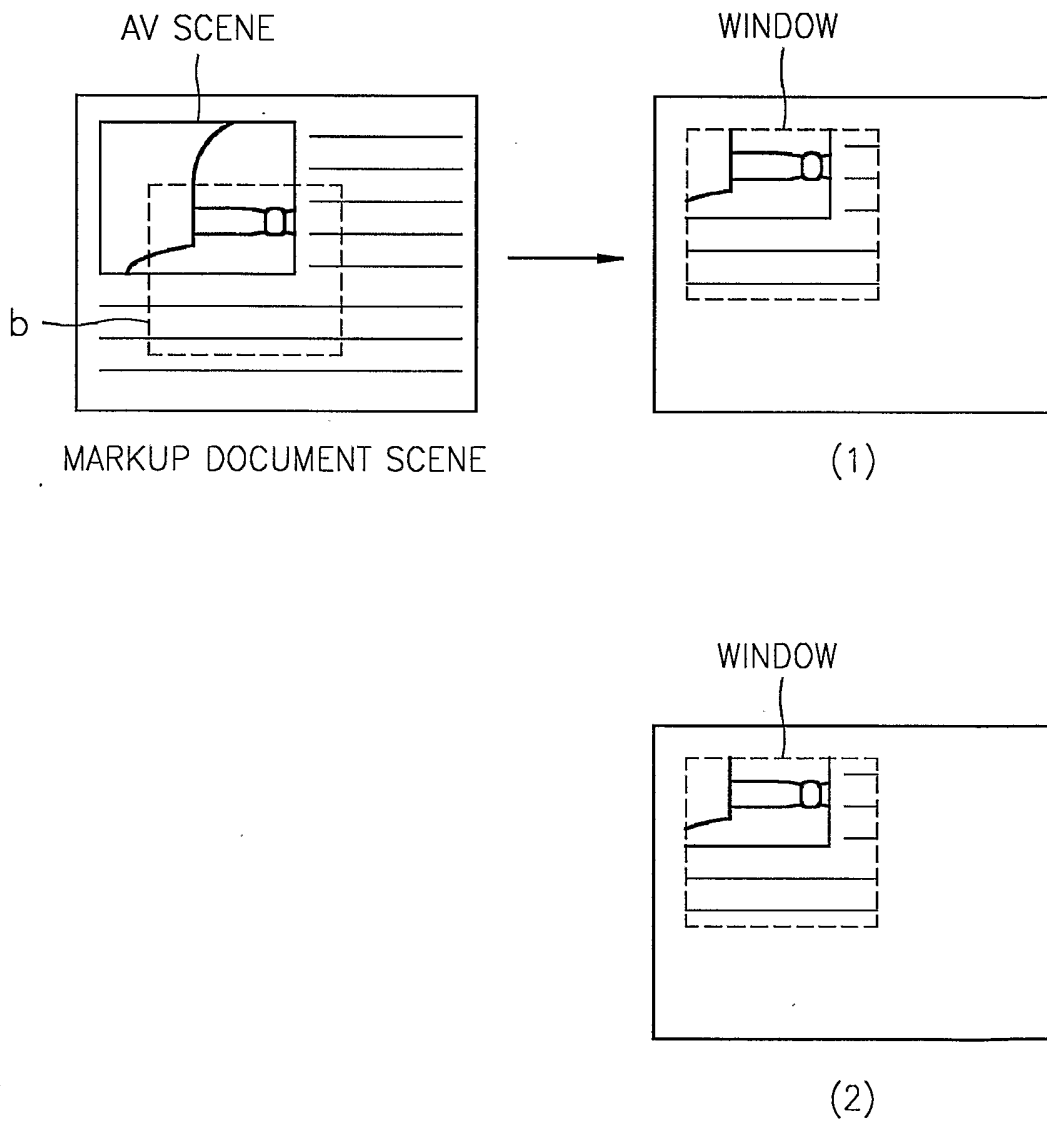

7/20

FIG. 9

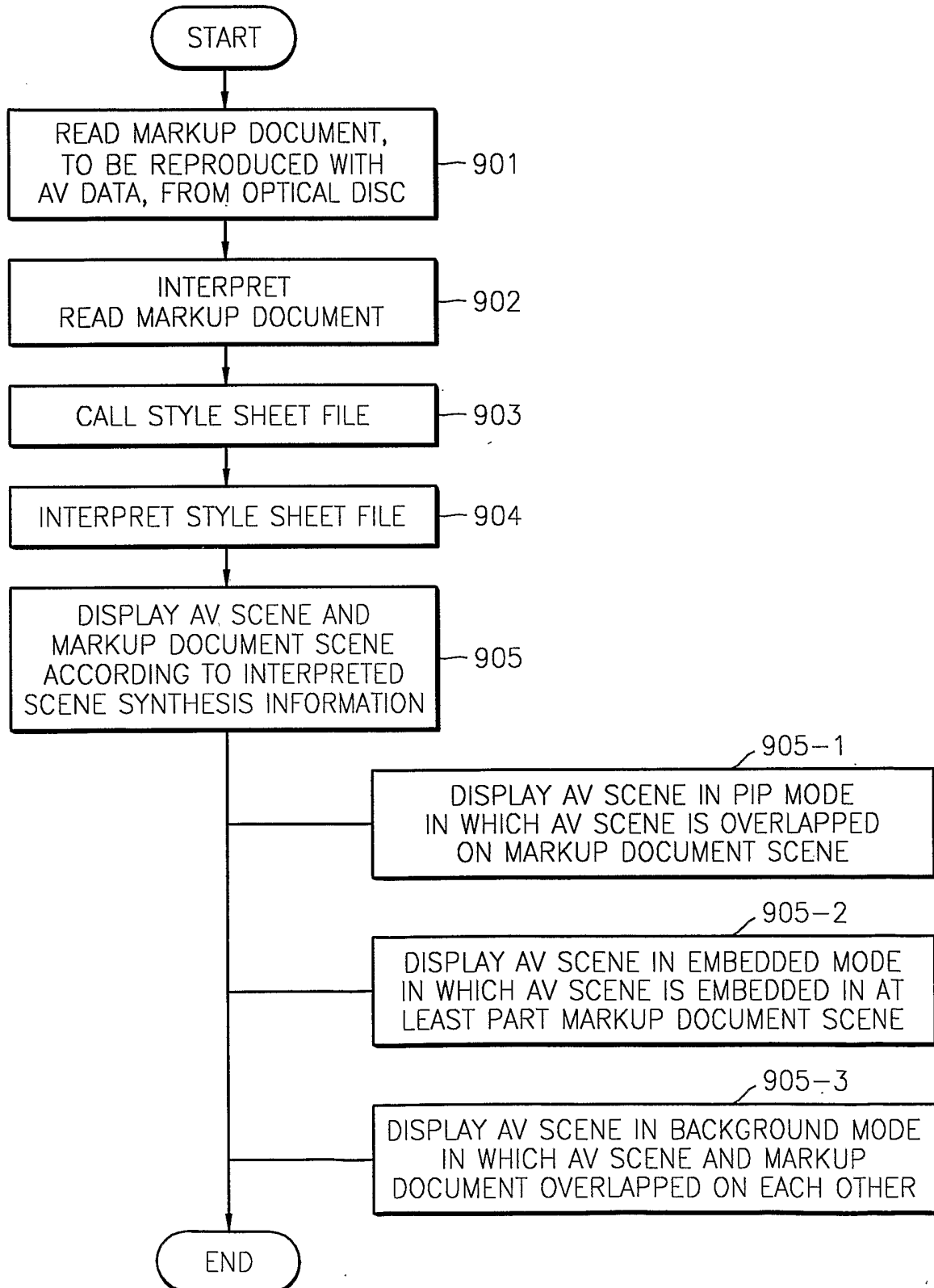

8/20  
**FIG. 10**

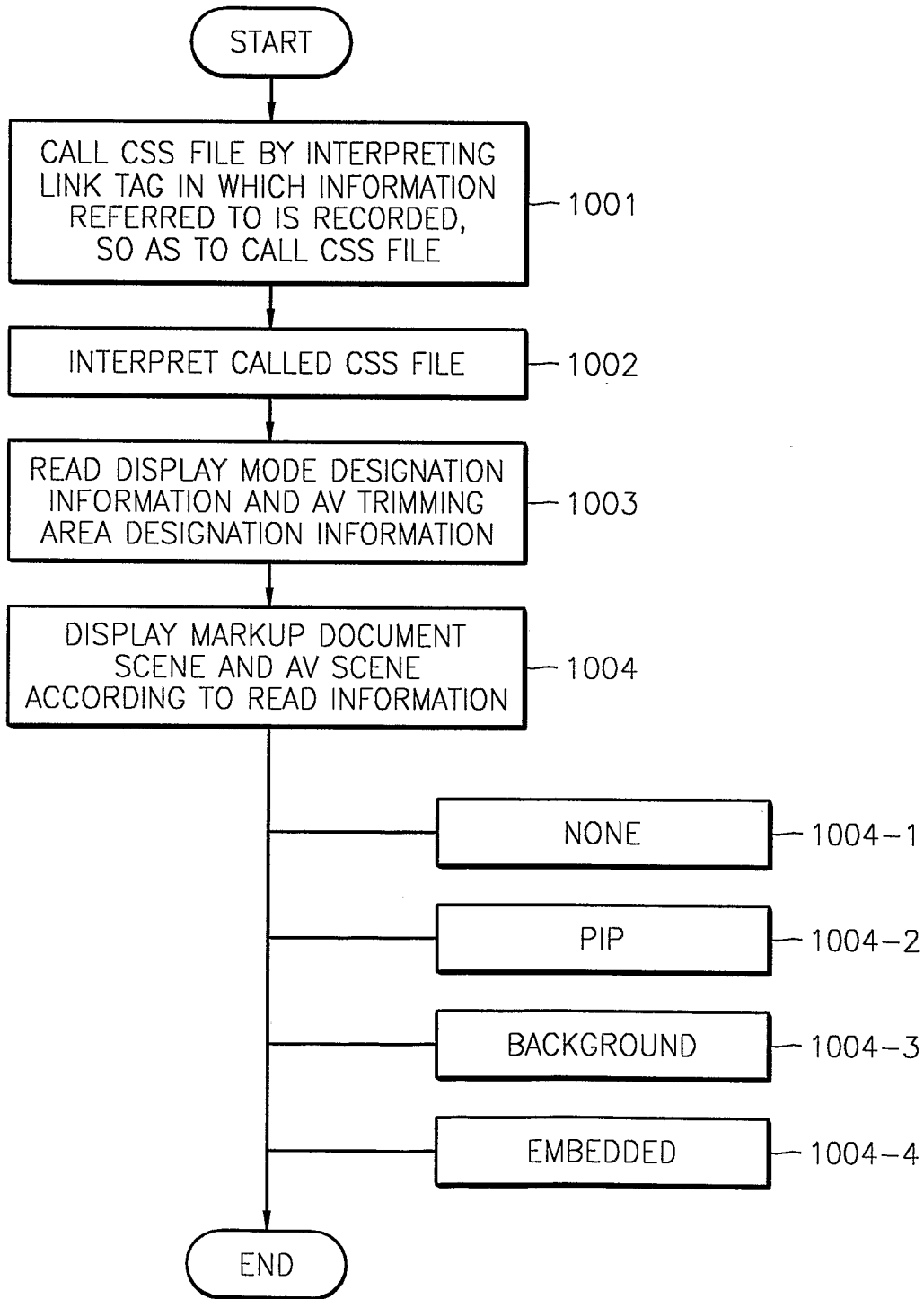

9/20

**FIG. 11**

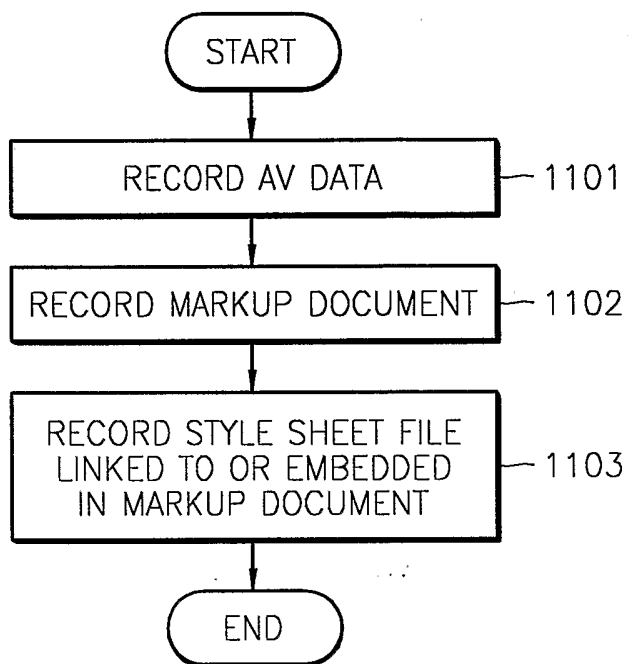

10/20

FIG. 12

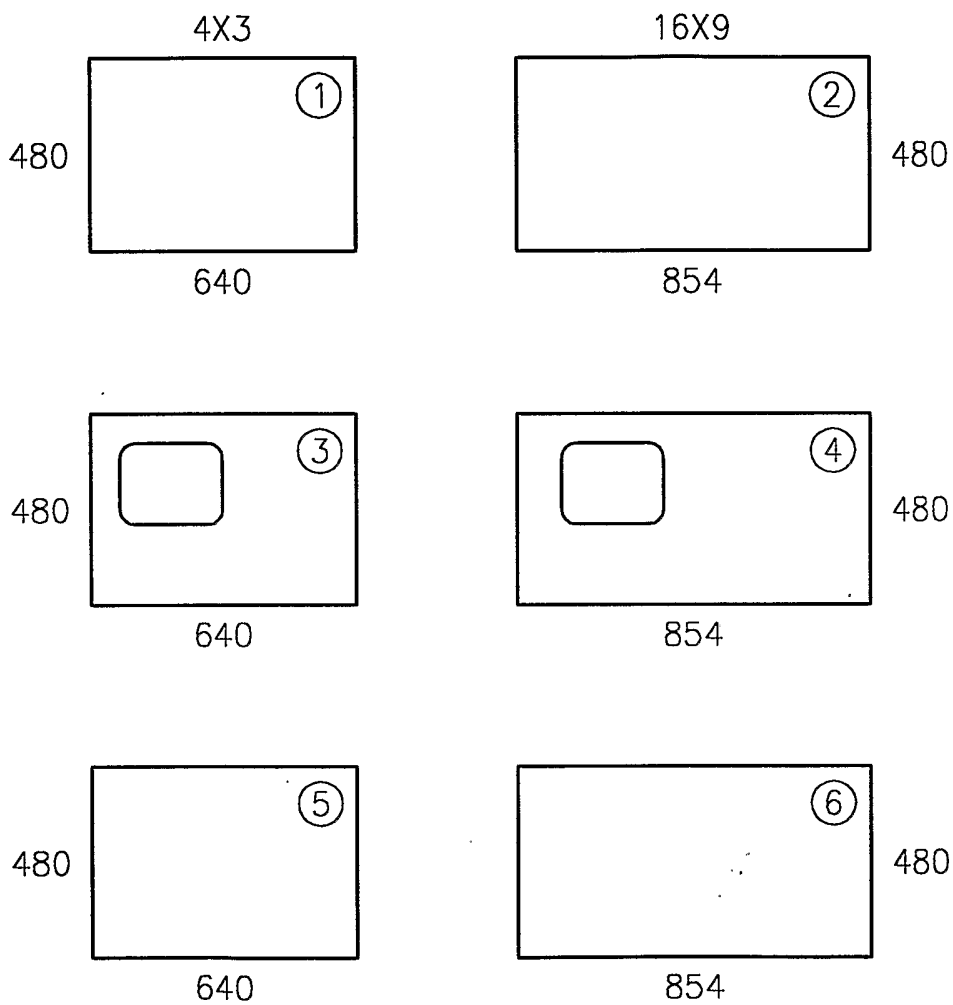

11/20

FIG. 13

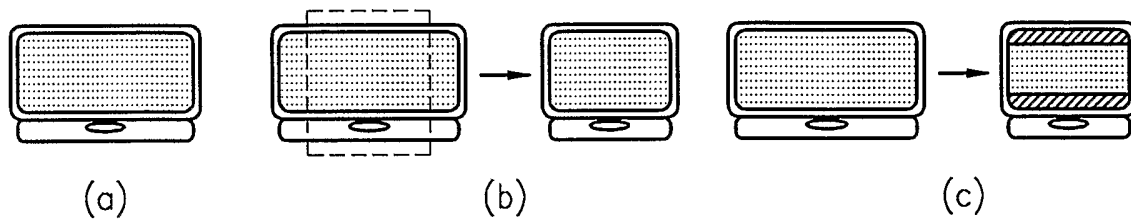
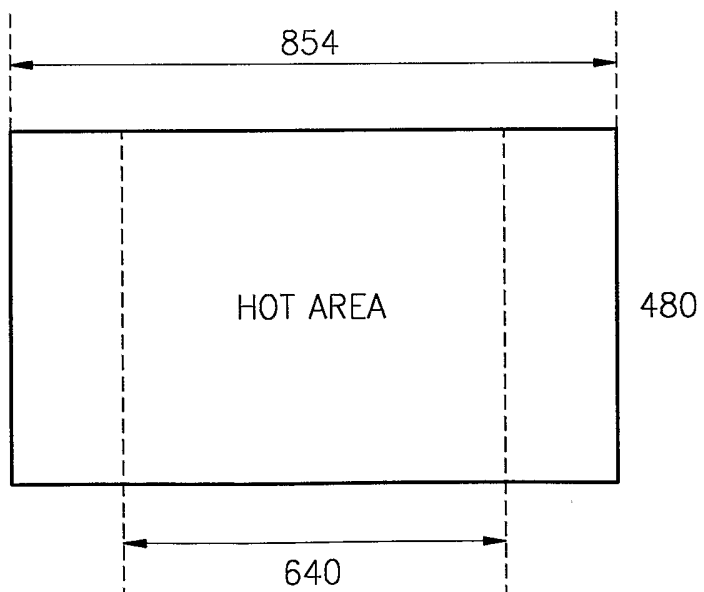
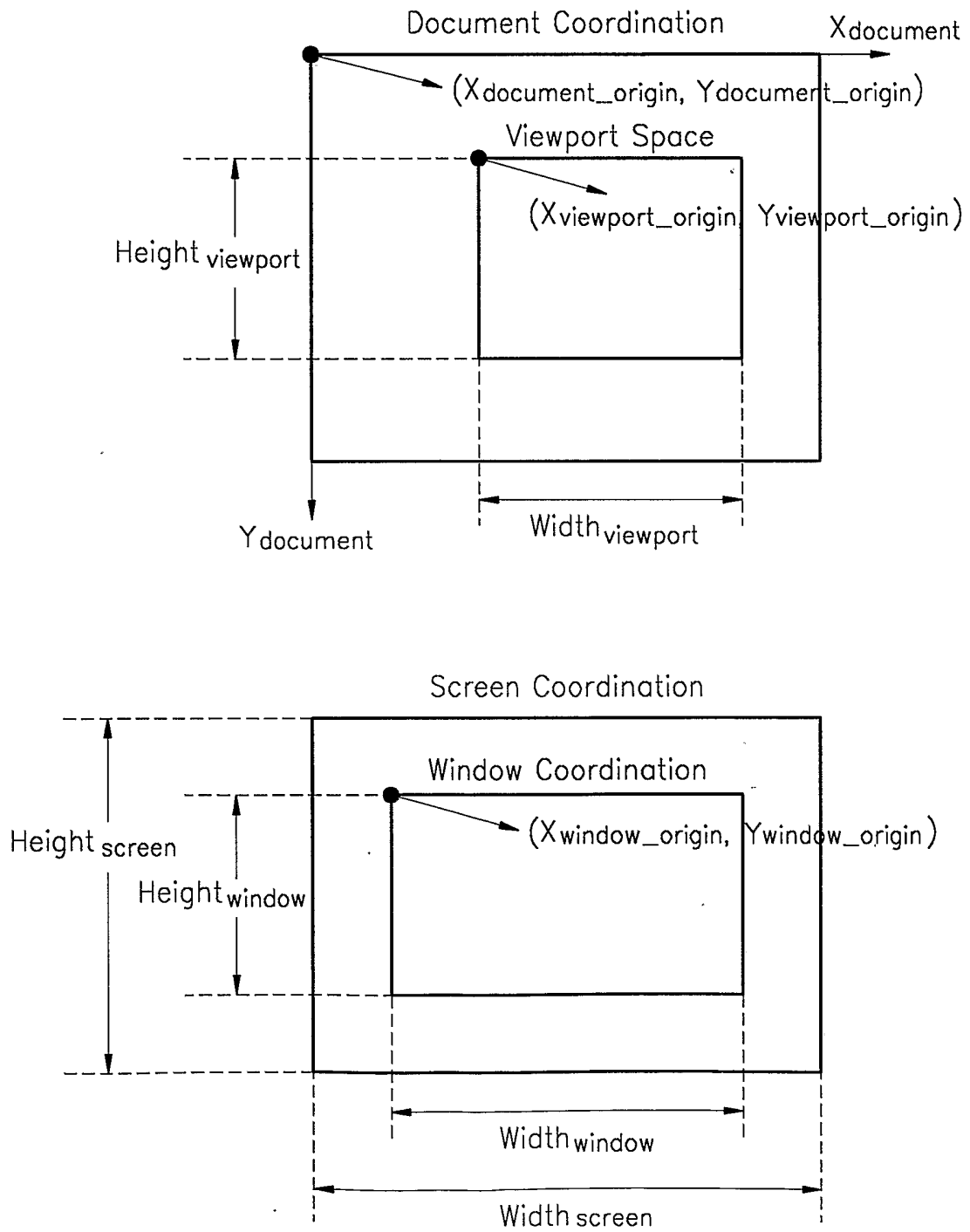

FIG. 14



12/20

FIG. 15



13/20  
FIG. 16

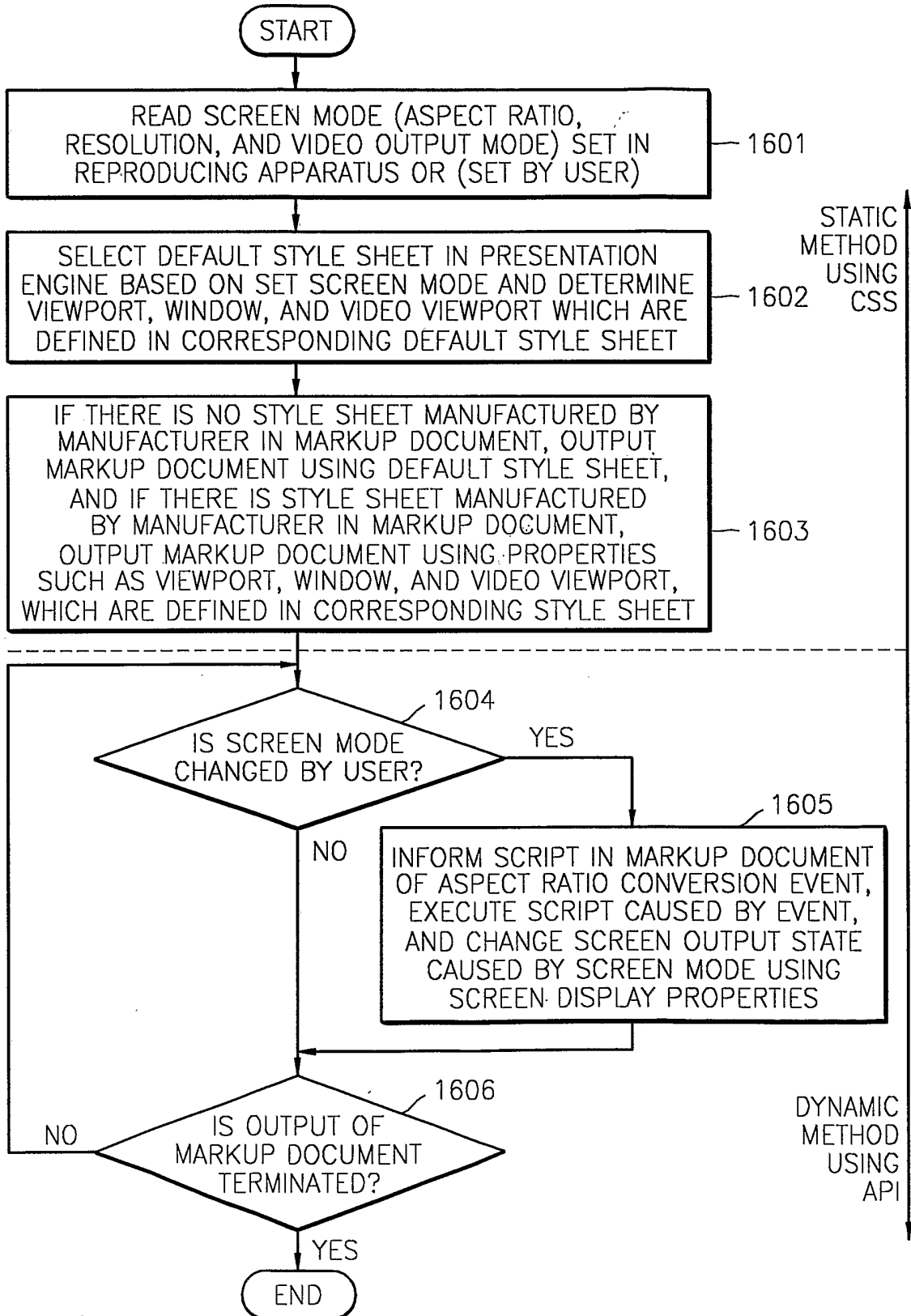



14/20

FIG. 17

16x9



(a)

4x3

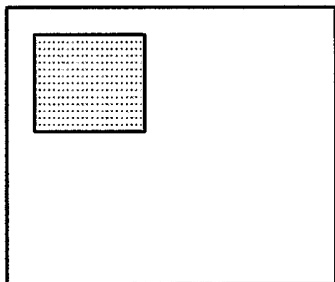

(b)

4x3

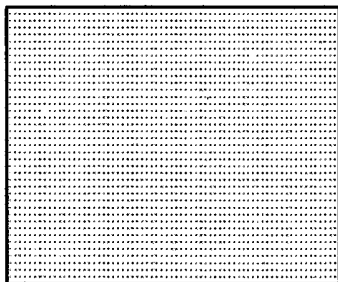

(c)

4x3

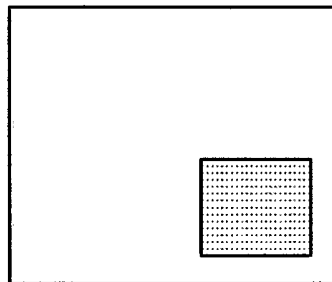

(d)

15/20

FIG. 18

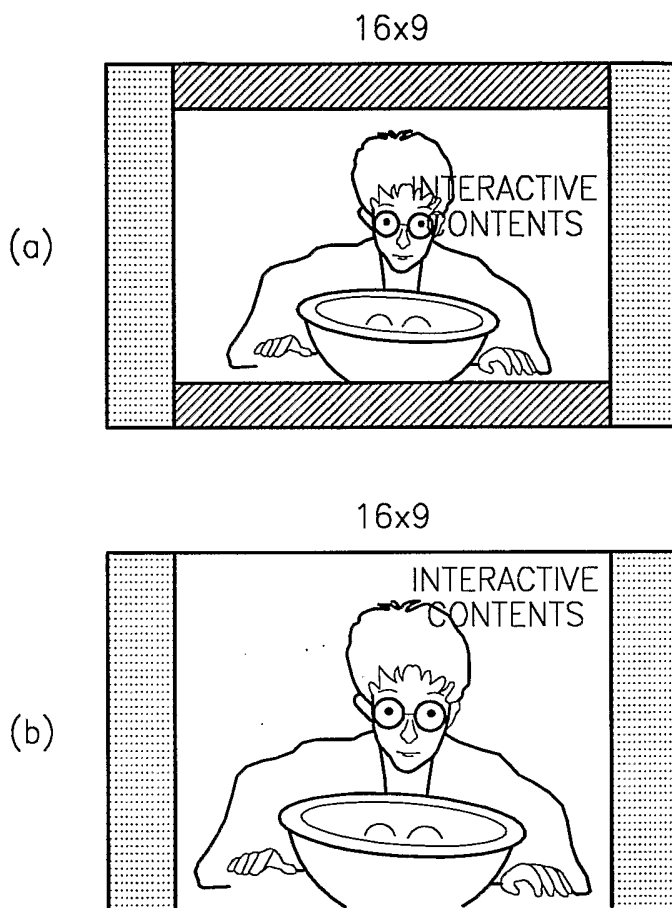

16/20

FIG. 19

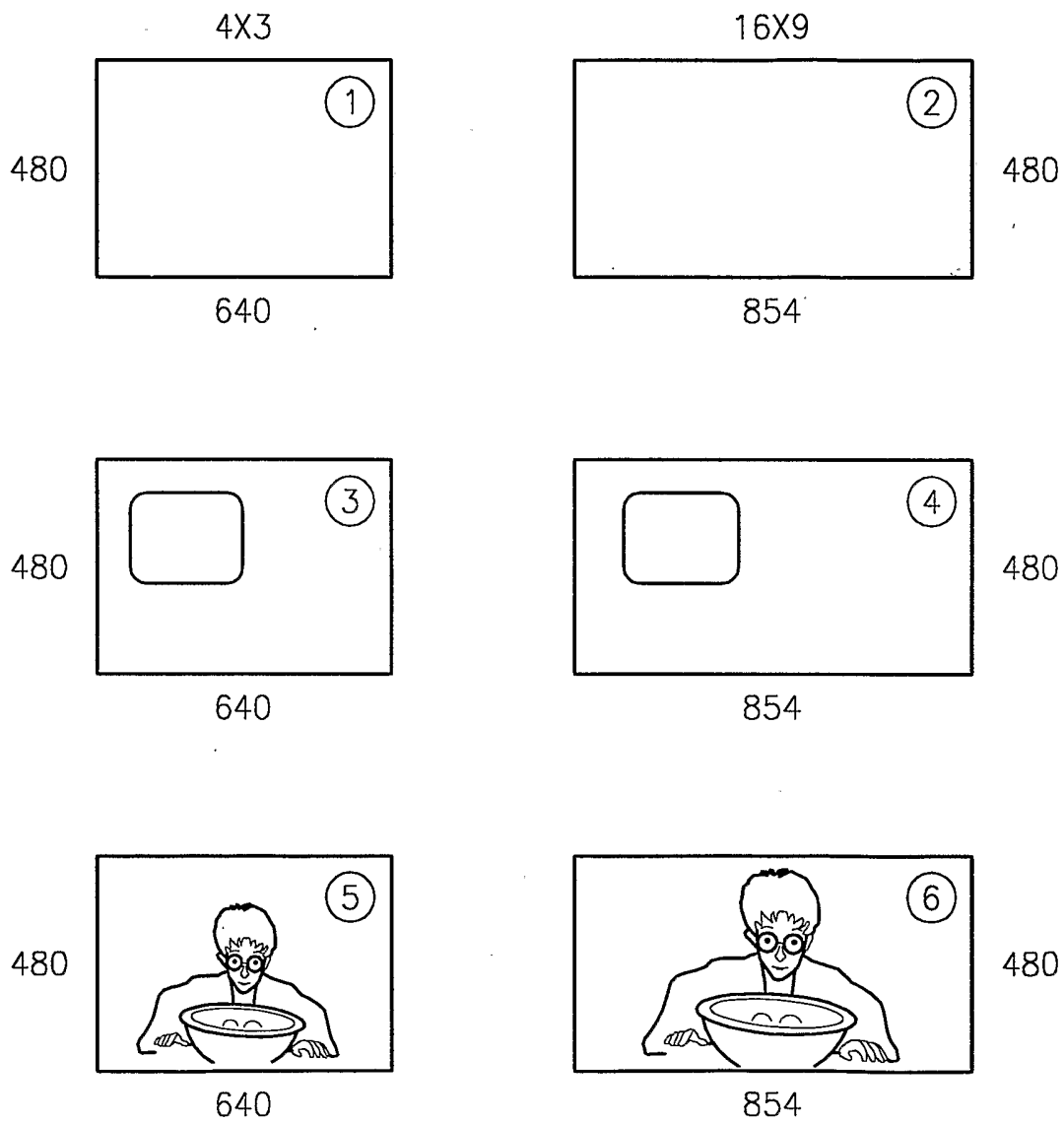

17/20

**FIG. 20**

(a)

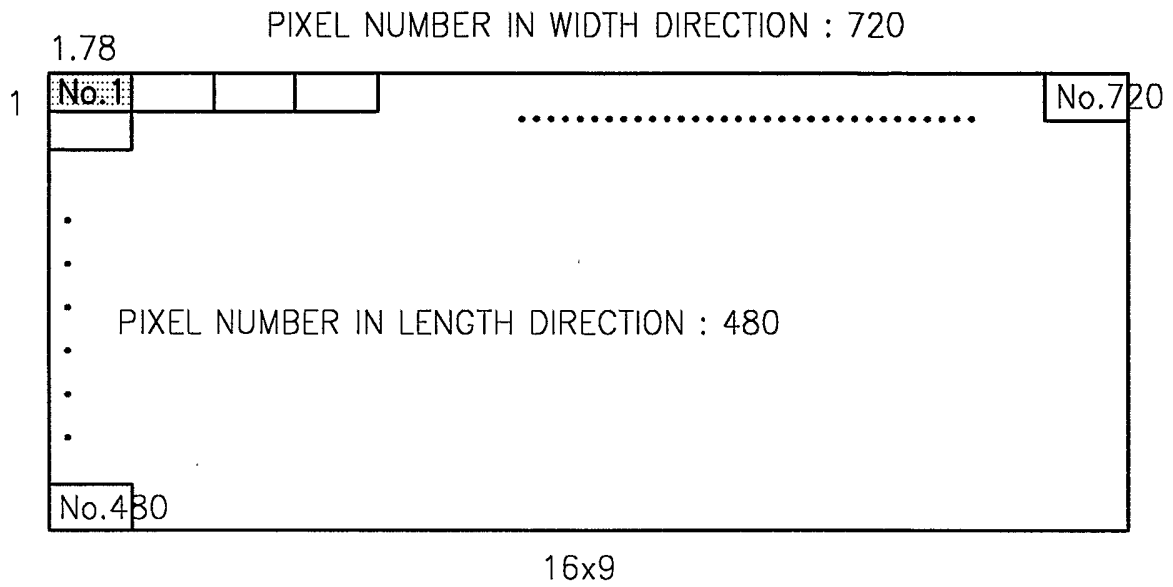

(b)

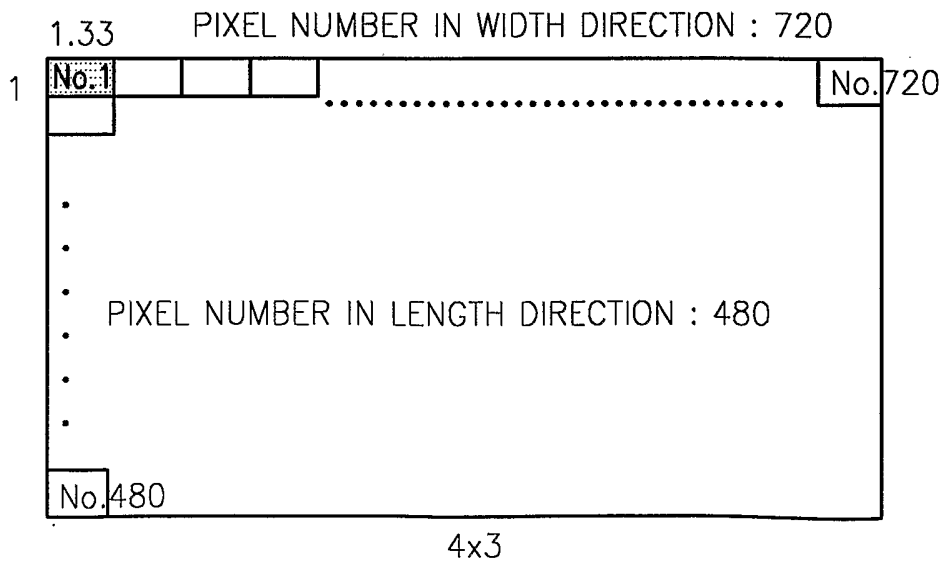

18/20

FIG. 21

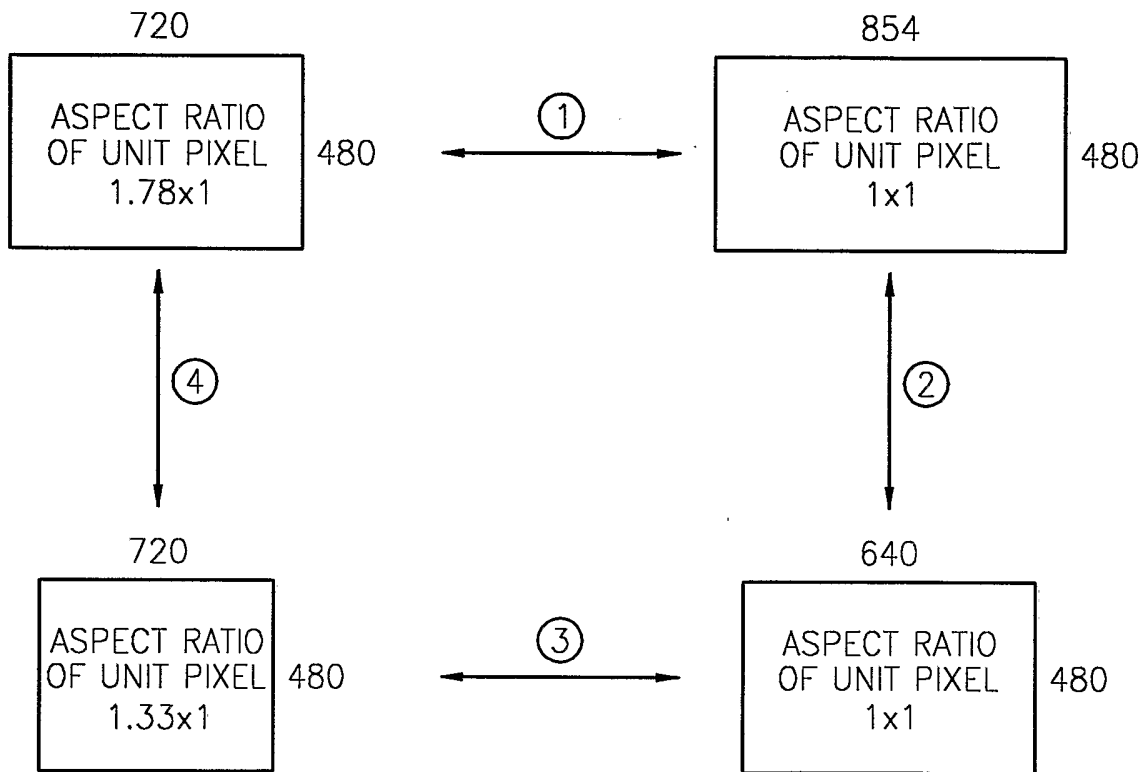

19/20

**FIG. 22**

16x9

(a)

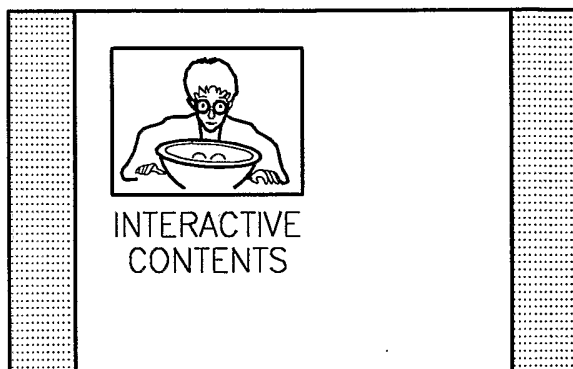

16x9

(b)



16x9

(c)

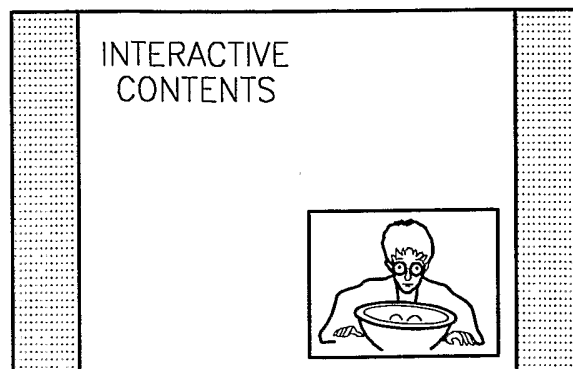

20/20  
FIG. 23

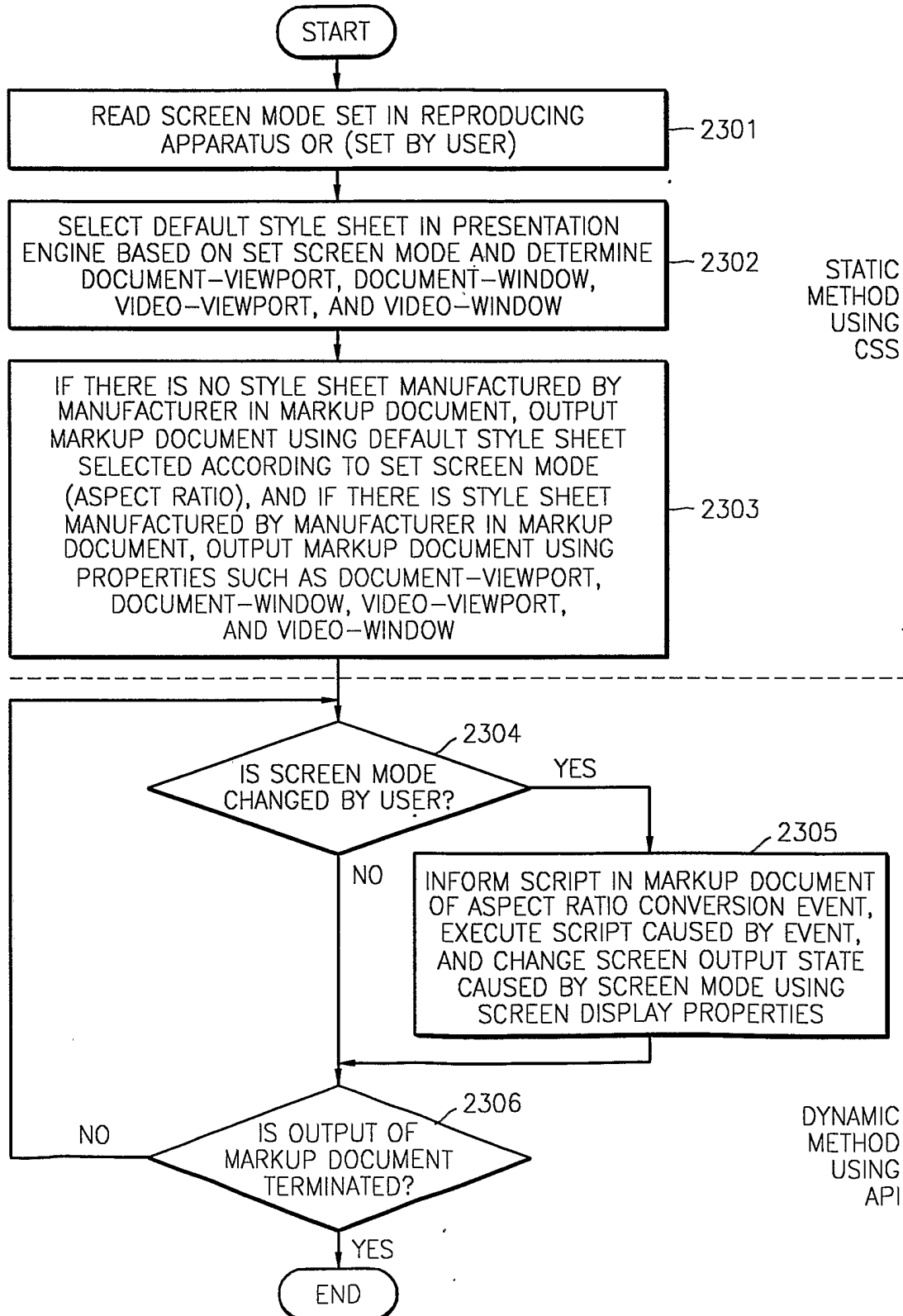

INTERNATIONAL SEARCH REPORT

International application No.  
PCT/KR02/01977

**A. CLASSIFICATION OF SUBJECT MATTER**  
**IPC7 G06F 3/14**  
According to International Patent Classification (IPC) or to both national classification and IPC

**B. FIELDS SEARCHED**  
Minimum documentation searched (classification system followed by classification symbols)  
IPC7 G06F 17/21, 17/30, H04N 7/01

Documentation searched other than minimum documentation to the extent that such documents are included in the fields searched  
KR : IPC as above

Electronic data base consulted during the international search (name of data base and, where practicable, search terms used)



**C. DOCUMENTS CONSIDERED TO BE RELEVANT**

Category*	Citation of document, with indication, where appropriate, of the relevant passages	Relevant to claim No.
A	KR 99-26743 A ( Sony Corp.) 15 April 1999 (15.04.99) See the Whole Document	68 - 74
A	KR 01-39796 A (International Business Machines Corp.) 15 May 2001 (15.05.01) See the Whole Document	75 - 78
A	KR 01-10471 A (Yoo-Soo, Ahn) 15 February 2001 (15.02.01) See the Whole document	81 - 90

Further documents are listed in the continuation of Box C.       See patent family annex.

\* Special categories of cited documents:  
 "A" document defining the general state of the art which is not considered to be of particular relevance  
 "E" earlier application or patent but published on or after the international filing date  
 "L" document which may throw doubts on priority claim(s) or which is cited to establish the publication date of citation or other special reason (as specified)  
 "O" document referring to an oral disclosure, use, exhibition or other means  
 "P" document published prior to the international filing date but later than the priority date claimed  
 "T" later document published after the international filing date or priority date and not in conflict with the application but cited to understand the principle or theory underlying the invention  
 "X" document of particular relevance; the claimed invention cannot be considered novel or cannot be considered to involve an inventive step when the document is taken alone  
 "Y" document of particular relevance; the claimed invention cannot be considered to involve an inventive step when the document is combined with one or more other such documents, such combination being obvious to a person skilled in the art  
 "&" document member of the same patent family

Date of the actual completion of the international search 29 JANUARY 2003 (29.01.2003)	Date of mailing of the international search report 29 JANUARY 2003 (29.01.2003)
---	--

Name and mailing address of the ISA/KR  Korean Intellectual Property Office 920 Dunsan-dong, Seo-gu, Daejeon 302-701, Republic of Korea Facsimile No. 82-42-472-7140	Authorized officer  SONG, In Kwan  Telephone No. 82-42-481-5708  
---	--



## INTERNATIONAL SEARCH REPORT

Information on patent family members

International application No.

PCT/KR02/01977

Patent document cited in search report	Publication date	Patent family member(s)	Publication date
KR 99-26743 A	15.04.99	None	
KR 01-39796 A	15.05.01	EP 1077421 A2 JP 2001101173 A2 CN1286436 A	02.21.01 04.13.01 03.07.01
KR 01-10471 A	15.02.01	None	