

(No Model.)

J. B. NOLAN.
SHELF BRACKET.

No. 541,114.

Patented June 18, 1895.

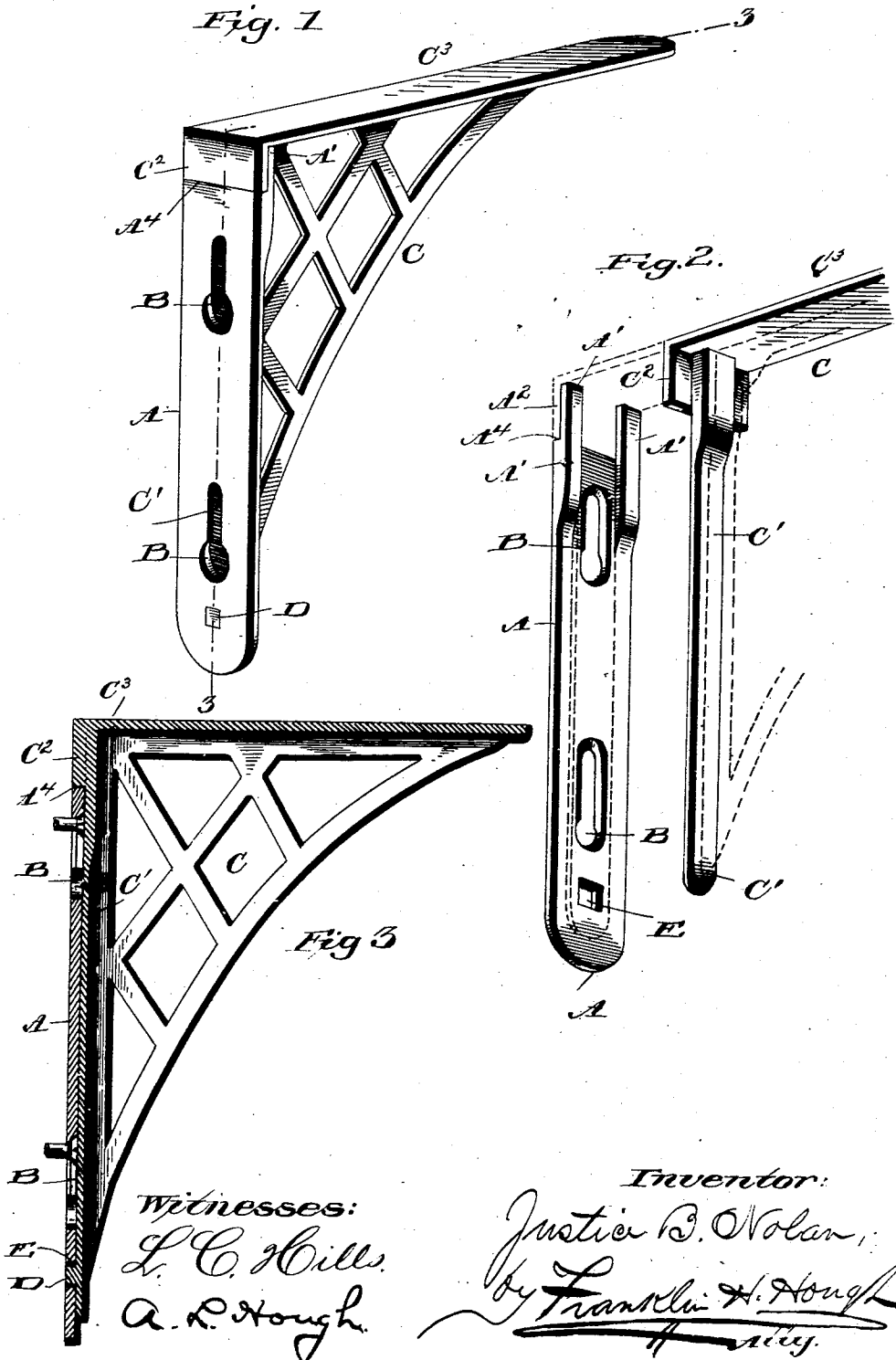

Witnesses:
L. C. Hills.
A. R. Hough.

Inventor:
Justice B. Nolan,
by Franklin H. Hough.

UNITED STATES PATENT OFFICE.

JUSTICE B. NOLAN, OF ELKHART, INDIANA.

SHELF-BRACKET.

SPECIFICATION forming part of Letters Patent No. 541,114, dated June 18, 1895.

Application filed March 30, 1895. Serial No. 543,833. (No model.)

To all whom it may concern:

Be it known that I, JUSTICE B. NOLAN, a citizen of the United States, residing at Elkhart, in the county of Elkhart and State of Indiana, have invented certain new and useful Improvements in Shelf-Brackets; and I do declare the following to be a full, clear, and exact description of the invention, such as will enable others skilled in the art to which it appertains to make and use the same, reference being had to the accompanying drawings, and to the letters of reference marked thereon, which form a part of this specification.

This invention relates to certain new and useful improvements in shelf-brackets, and it has for its object the provision of a cheaply constructed and at the same time strong and serviceable bracket which is composed of two parts one of which is attached to the wall, the shelf supporting portion of the bracket being adapted to be removably attached to the portion upon the wall, in such a manner as to effectually conceal the screw or nail heads of the screws or nails used in securing the wall portion in place.

To these ends and to such others as the invention may relate, the same consists in the peculiar construction, and in the novel combination, arrangement and adaptation of parts, all as more fully hereinafter described, shown in the accompanying drawings, and then specifically defined in the appended claim.

The invention is clearly illustrated in the accompanying drawings, which, with the letters of reference marked thereon, form a part of this specification, and in which—

Figure 1 is a rear perspective view of a shelf-bracket embodying my improvements. Fig. 2 is a front perspective view upon a larger scale of the two parts of the bracket separated, but in their relative positions. Fig. 3 is a section upon the line 3 3 of Fig. 1.

Reference now being had to the details of the drawings by letter, A designates the portion of the bracket which is attached to the wall, and which I will denominate the "wall strip." This strip has its rear face, which is adapted to fit against the face of the wall, flat. This strip A is provided at intervals of its length with openings B, B which are larger at their lower ends than at the upper ends thus permitting the strip to be readily placed

over the heads of the screws or nails placed in the wall. It will be seen that as soon as the said nail or screw heads have been passed through the openings that a downward pressure upon the strip will cause the narrow upper ends of the elongated openings B to engage the screw heads, thus preventing the removal of the strip from the wall until the strip is forced upward so as to cause the heads of the screws or nails to again register with the enlarged lower ends of the said openings B. In order that the heads of the screws or nails may be flush with or below the surface of the strip the outer edges of the openings B are beveled, as shown.

The upper end of the strip A is provided with two vertical arms or projections A', A' between which is received the strip or portion C' of the bracket C. The rear faces of the said arms A' are flush with the front face of the strip A, thus providing a space A², within which is seated the extension C² at the inner end of the horizontal shelf supporting arm C³ of the bracket, the lower end of said portion C² being seated against the upper end of the body portion of the wall strip A, as shown at A¹. At a point near its lower end, the strip C' is provided with an angular lug D, which engages a correspondingly shaped opening E in the wall strip thus preventing lateral movement of the lower end of the strip C', while the upper end of the said strip is securely held in place between the arms A' upon the wall strip.

It will be seen that when in place, the strip C' of the bracket will pass vertically downward over the longitudinal center of the wall strip A, thus covering the heads of the nails or screws which are employed in attaching the said strip A to the wall.

The bracket may be readily removed from the wall by simply disengaging the lug at the lower end of the strip C' from the wall strip, when the strip C' may be slid upward and removed from the wall strip. By moving the wall strip upward it will be released from the nail or screw heads which retain it in place, when it too may be removed from the wall.

It will be seen that the engagement of the lug D with the opening in the lower end of the wall strip will serve to lock the two parts of the bracket against vertical displacement.

Having thus described my invention, what I claim to be new, and desire to secure by Letters Patent, is—

5 As an improved article of manufacture a shelf bracket consisting of the portion A, the integral outwardly bulging and upwardly extending portions A', the shoulders A⁴, combined with the bracket arm having the shelf supporting portion C³ with its rear end bent at right angles forming the wings C² which are integral with the rear bulging portion of the strip c', the said bracket supporting arm,

when applied to the portion A, to have a bearing on the tops and the backs of the portions A', and the lug D designed to be seated in an aperture E, all substantially as shown and described.

In testimony whereof I affix my signature in presence of two witnesses.

JUSTICE B. NOLAN.

Witnesses:

ELLIE M. CHESTER,
WILLIAM H. ANDERSON.