

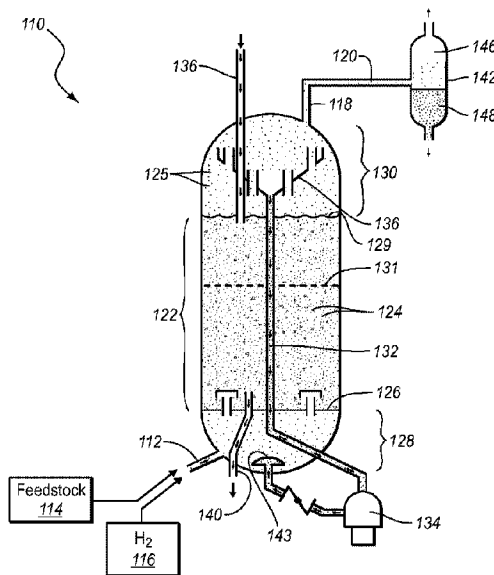

(86) Date de dépôt PCT/PCT Filing Date: 2017/06/07
 (87) Date publication PCT/PCT Publication Date: 2017/12/14
 (45) Date de délivrance/Issue Date: 2024/04/16
 (85) Entrée phase nationale/National Entry: 2018/11/22
 (86) N° demande PCT/PCT Application No.: US 2017/036324
 (87) N° publication PCT/PCT Publication No.: 2017/214256
 (30) Priorités/Priorities: 2016/06/08 (US62/347,304);
 2017/06/06 (US15/615,574)

(51) Cl.Int./Int.Cl. *C10G 49/12* (2006.01),
C10G 49/26 (2006.01)
 (72) Inventeurs/Inventors:
 MOUNTAINLAND, DAVID, US;
 SILVERMAN, BRETT M., US;
 RUETER, MICHAEL, US;
 SMITH, LEE, US
 (73) Propriétaire/Owner:
 HYDROCARBON TECHNOLOGY & INNOVATION, LLC,
 US
 (74) Agent: CASSAN MACLEAN IP AGENCY INC.

(54) Titre : SYSTEME CATALYSEUR DOUBLE DESTINE A L'ENRICHISSEMENT D'UN LIT BOUILLONNANT EN VUE DE PRODUIRE UN PRODUIT DE RESIDU SOUS VIDE DE QUALITE AMELIOREE
 (54) Title: DUAL CATALYST SYSTEM FOR EBULLATED BED UPGRADING TO PRODUCE IMPROVED QUALITY VACUUM RESIDUE PRODUCT



(57) **Abrégé/Abstract:**

An ebullated bed hydroprocessing system is upgraded using a dual catalyst system that includes a heterogeneous catalyst and dispersed metal sulfide particles to improve the quality of vacuum residue. The improved quality of vacuum residue can be provided by one or more of reduced viscosity, reduced density (increased API gravity), reduced asphaltene content, reduced carbon residue content, reduced sulfur content, and reduced sediment. Vacuum residue of improved quality can be produced while operating the upgraded ebullated bed reactor at the same or higher severity, temperature, throughput and/or conversion. Similarly, vacuum residue of same or higher quality can be produced while operating the upgraded ebullated bed reactor at higher severity, temperature, throughput and/or conversion.

(12) INTERNATIONAL APPLICATION PUBLISHED UNDER THE PATENT COOPERATION TREATY (PCT)

(19) World Intellectual Property
Organization
International Bureau(43) International Publication Date
14 December 2017 (14.12.2017)(10) International Publication Number
WO 2017/214256 A1

(51) International Patent Classification:

C10G 49/12 (2006.01) C10G 49/26 (2006.01)

(21) International Application Number:

PCT/US2017/036324

(22) International Filing Date:

07 June 2017 (07.06.2017)

(25) Filing Language:

English

(26) Publication Language:

English

(30) Priority Data:

62/347,304 08 June 2016 (08.06.2016) US
15/615,574 06 June 2017 (06.06.2017) US(71) Applicant: **HEADWATERS HEAVY OIL, LLC**
[US/US]; 10653 South River Front Parkway, Suite 300,
South Jordan, Utah 84095 (US).(72) Inventors: **MOUNTAINLAND, David**; 23 Southern Way,
Princeton, New Jersey 08540 (US). **SILVERMAN, Brett M.**;
2568 East 3020 South, Salt Lake City, Utah 84109 (US).
REUTER, Michael; 350 Maiden Lane, Plymouth Meeting,
Pennsylvania 19462 (US). **SMITH, Lee**; 2120 North 600
West, Pleasant Grove, Utah 84062 (US).(74) Agent: **GUYNN, John M.**; Workman Nydegger, 60 East
South Temple, Suite 1000, Salt Lake City, Utah 84111 (US).

(81) Designated States (unless otherwise indicated, for every

kind of national protection available): AE, AG, AL, AM,
AO, AT, AU, AZ, BA, BB, BG, BH, BN, BR, BW, BY, BZ,
CA, CH, CL, CN, CO, CR, CU, CZ, DE, DJ, DK, DM, DO,
DZ, EC, EE, EG, ES, FI, GB, GD, GE, GH, GM, GT, HN,
HR, HU, ID, IL, IN, IR, IS, JP, KE, KG, KH, KN, KP, KR,
KW, KZ, LA, LC, LK, LR, LS, LU, LY, MA, MD, ME, MG,
MK, MN, MW, MX, MY, MZ, NA, NG, NI, NO, NZ, OM,
PA, PE, PG, PH, PL, PT, QA, RO, RS, RU, RW, SA, SC,
SD, SE, SG, SK, SL, SM, ST, SV, SY, TH, TJ, TM, TN, TR,
TT, TZ, UA, UG, US, UZ, VC, VN, ZA, ZM, ZW.

(84) Designated States (unless otherwise indicated, for every

kind of regional protection available): ARIPO (BW, GH,
GM, KE, LR, LS, MW, MZ, NA, RW, SD, SL, ST, SZ, TZ,
UG, ZM, ZW), Eurasian (AM, AZ, BY, KG, KZ, RU, TJ,
TM), European (AL, AT, BE, BG, CH, CY, CZ, DE, DK,
EE, ES, FI, FR, GB, GR, HR, HU, IE, IS, IT, LT, LU, LV,
MC, MK, MT, NL, NO, PL, PT, RO, RS, SE, SI, SK, SM,
TR), OAPI (BF, BJ, CF, CG, CI, CM, GA, GN, GQ, GW,
KM, ML, MR, NE, SN, TD, TG).

Published:

— with international search report (Art. 21(3))

(54) Title: DUAL CATALYST SYSTEM FOR EBULLATED BED UPGRADING TO PRODUCE IMPROVED QUALITY VACUUM RESIDUE PRODUCT

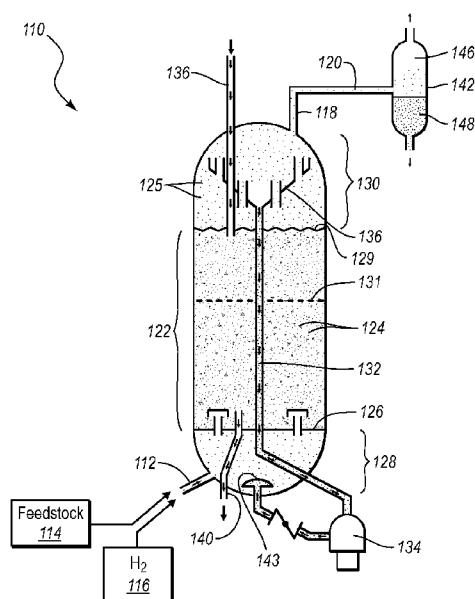

Fig. 2B

(57) Abstract: An ebullated bed hydroprocessing system is upgraded using a dual catalyst system that includes a heterogeneous catalyst and dispersed metal sulfide particles to improve the quality of vacuum residue. The improved quality of vacuum residue can be provided by one or more of reduced viscosity, reduced density (increased API gravity), reduced asphaltene content, reduced carbon residue content, reduced sulfur content, and reduced sediment. Vacuum residue of improved quality can be produced while operating the upgraded ebullated bed reactor at the same or higher severity, temperature, throughput and/or conversion. Similarly, vacuum residue of same or higher quality can be produced while operating the upgraded ebullated bed reactor at higher severity, temperature, throughput and/or conversion.



WO 2017/214256 A1

DUAL CATALYST SYSTEM FOR EBULLATED BED UPGRADING TO
PRODUCE IMPROVED QUALITY VACUUM RESIDUE PRODUCT

BACKGROUND OF THE INVENTION

1. The Field of the Invention

[0001] The invention relates to heavy oil hydroprocessing methods and systems, such as ebullated bed hydroprocessing methods and systems, which utilize a dual catalyst system to produce upgraded hydrocarbon products, including vacuum residue product of improved quality.

2. The Relevant Technology

[0002] There is an ever-increasing demand to more efficiently utilize low quality heavy oil feedstocks and extract fuel values therefrom. Low quality feedstocks are characterized as including relatively high quantities of hydrocarbons that nominally boil at or above 524°C (975°F). They also contain relatively high concentrations of sulfur, nitrogen and/or metals. High boiling fractions derived from these low quality feedstocks typically have a high molecular weight (often indicated by higher density and viscosity) and/or low hydrogen/carbon ratio, which is related to the presence of high concentrations of undesirable components, including asphaltenes and carbon residue. Asphaltenes and carbon residue are difficult to process and commonly cause fouling of conventional catalysts and hydroprocessing equipment because they contribute to the formation of coke and sediment. Furthermore, carbon residue places limitations on downstream processing of high boiling fractions, such as when they are used as feeds for coking processes.

[0003] Lower quality heavy oil feedstocks which contain higher concentrations of asphaltenes, carbon residue, sulfur, nitrogen, and metals include heavy crude, oil sands bitumen, and residuum left over from conventional refinery process. Residuum (or “resid”) can refer to atmospheric tower bottoms and vacuum tower bottoms. Atmospheric tower bottoms can have a boiling point of at least 343°C (650°F) although it is understood that the cut point can vary among refineries and be as high as 380°C (716°F). Vacuum tower bottoms (also known as “resid pitch” or “vacuum residue”) can have a boiling point of at least 524°C (975°F), although it is understood that the cut point can vary among refineries and be as high as 538°C (1000°F) or even 565°C (1050°F).

[0004] By way of comparison, Alberta light crude contains about 9% by volume vacuum residue, while Lloydminster heavy oil contains about 41% by volume vacuum residue, Cold Lake bitumen contains about 50% by volume vacuum residue, and Athabasca bitumen contains about 51% by volume vacuum residue. As a further comparison, a relatively light oil such as Dansk Blend from the North Sea region only contains about 15% vacuum residue, while a lower-quality European oil such as Ural contains more than 30% vacuum residue, and an oil such as Arab Medium is even higher, with about 40% vacuum residue. These examples highlight the importance of being able to convert vacuum residues when lower-quality crude oils are used.

[0005] Converting heavy oil into useful end products involves extensive processing, such as reducing the boiling point of the heavy oil, increasing the hydrogen-to-carbon ratio, and removing impurities such as metals, sulfur, nitrogen and coke precursors. Examples of hydrocracking processes using conventional heterogeneous catalysts to upgrade atmospheric tower bottoms include fixed-bed hydroprocessing, ebullated-bed hydroprocessing, and moving-bed hydroprocessing. Noncatalytic upgrading processes for upgrading vacuum tower bottoms include thermal cracking, such as delayed coking, flexicoking, visbreaking, and solvent extraction.

SUMMARY OF THE INVENTION

[0006] Disclosed herein are methods for upgrading an ebullated bed hydroprocessing system to convert hydrocarbon products from heavy oil and produce vacuum residue products of improved quality. Also disclosed are methods and upgraded ebullated bed hydroprocessing systems to converted hydrocarbon products and produce vacuum residue products of improved quality. The disclosed methods and systems involve the use of a dual catalyst system comprised of a solid supported (*i.e.*, heterogeneous) catalyst and well-dispersed (*e.g.*, homogeneous) catalyst particles. The dual catalyst system can be employed to upgrade an ebullated bed hydroprocessing system that otherwise utilizes a single catalyst composed of a solid supported ebullated bed catalyst.

[0007] In some embodiments, a method of upgrading an ebullated bed hydroprocessing system to produce converted products from heavy oil, including vacuum residue products of improved quality, comprises: (1) operating an ebullated bed reactor using a heterogeneous catalyst to hydroprocess heavy oil and produce converted products, including a vacuum residue product of

initial quality; (2) thereafter upgrading the ebullated bed reactor to operate using a dual catalyst system comprised of dispersed metal sulfide catalyst particles and heterogeneous catalyst; and (3) operating the upgraded ebullated bed reactor to produce converted products, including a vacuum residue product of improved quality compared to when initially operating the ebullated bed reactor.

[0008] The quality of a vacuum residue product of a given boiling point or range is typically understood to be a function of the viscosity, density, asphaltene content, carbon residue content, sulfur content, and sediment content. It may also involve nitrogen content and metals content. The methods and systems disclosed herein produce vacuum residue products having improved quality as defined by one or more of: (a) reduced viscosity, (b) reduced density (increased API gravity), (c) reduced asphaltene content, (d) reduced carbon residue content, (e) reduced sulfur content, (f) reduced nitrogen content, and (g) reduced sediment content. In some or most cases, more than one of the quality factors is improved, and in many cases, most or all of the quality factors can be improved, including at least reduced viscosity, reduced asphaltene content, reduced carbon residue content, reduced sulfur content, and reduced sediment content.

[0009] In some embodiments, the vacuum residue product of improved quality can be characterized by a reduction in viscosity (*e.g.*, as measured by Brookfield Viscosity at 300°F) of at least 10%, 15%, 20%, 25%, 30%, 40%, 50%, 60%, or 70% compared to when initially operating the ebullated bed reactor.

[0010] In some embodiments, the vacuum residue product of improved quality can be characterized by a reduction in asphaltene content of at least 5%, 7.5%, 10%, 12.5%, 15%, 20%, 25%, or 30% compared to when initially operating the ebullated bed reactor.

[0011] In some embodiments, the vacuum residue product of improved quality can be characterized by a reduction in micro carbon residue content (*e.g.*, as measured by MCR content) of at least 2%, 4%, 6%, 8%, 10%, 12.5%, 15%, or 20% compared to when initially operating the ebullated bed reactor.

[0012] In some embodiments, the vacuum residue product of improved quality can be characterized by a reduction in sulfur content of at least 5%, 7.5%, 10%, 15%, 20%, 25%, 30%, or 35% compared to when initially operating the ebullated bed reactor.

[0013] In some embodiments, the vacuum residue product of improved quality can be characterized by a reduction in density, which can be expressed as an increase in °API Gravity of

at least 0.4, 0.6, 0.8, 1.0, 1.3, 1.6, 2.0, 2.5 or 3.0, compared to when initially operating the ebullated bed reactor.

[0014] In some embodiments, the vacuum residue product of improved quality can be characterized by a reduction in sediment content of at least 2%, 4%, 6%, 8%, 10%, 12.5%, 15%, or 20% compared to when initially operating the ebullated bed reactor.

[0015] In general, vacuum residue products can be used for fuel oil, solvent deasphalting, coking, power plant fuel, and/or partial oxidation (*e.g.*, gasification to generate hydrogen). Because of restrictions on the amount of contaminants that are permitted in fuel oil, improving the quality of vacuum residue products using the dual catalyst system hydroprocessing systems disclosed herein can reduce the amount of more expensive cutter stocks otherwise required to bring the vacuum residue within specification. It can also reduce the burden on the overall process where the cutter stock can be utilized elsewhere for more efficient operation of the overall hydroprocessing system.

[0016] In some embodiments, the dispersed metal sulfide catalyst particles are less than 1 μm in size, or less than about 500 nm in size, or less than about 250 nm in size, or less than about 100 nm in size, or less than about 50 nm in size, or less than about 25 nm in size, or less than about 10 nm in size, or less than about 5 nm in size.

[0017] In some embodiments, the dispersed metal sulfide catalyst particles are formed *in situ* within the heavy oil from a catalyst precursor. By way of example and not limitation, the dispersed metal sulfide catalyst particles can be formed by blending a catalyst precursor into an entirety of the heavy oil prior to thermal decomposition of the catalyst precursor and formation of active metal sulfide catalyst particles. By way of further example, methods may include mixing a catalyst precursor with a diluent hydrocarbon to form a diluted precursor mixture, blending the diluted precursor mixture with the heavy oil to form conditioned heavy oil, and heating the conditioned heavy oil to decompose the catalyst precursor and form the dispersed metal sulfide catalyst particles *in situ* within the heavy oil.

[0018] These and other advantages and features of the present invention will become more fully apparent from the following description and appended claims, or may be learned by the practice of the invention as set forth hereinafter.

BRIEF DESCRIPTION OF THE DRAWINGS

[0019] To further clarify the above and other advantages and features of the present invention, a more particular description of the invention will be rendered by reference to specific embodiments thereof which are illustrated in the appended drawings. It is appreciated that these drawings depict only typical embodiments of the invention and are therefore not to be considered limiting of its scope. The invention will be described and explained with additional specificity and detail through the use of the accompanying drawings, in which:

[0020] Figure 1 depicts a hypothetical molecular structure of asphaltene;

[0021] Figures 2A and 2B schematically illustrate exemplary ebullated bed reactors;

[0022] Figure 2C schematically illustrates an exemplary ebullated bed hydroprocessing system comprising multiple ebullated bed reactors;

[0023] Figure 2D schematically illustrates an exemplary ebullated bed hydroprocessing system comprising multiple ebullated bed reactors and an interstage separator between two of the reactors;

[0024] Figure 3A is a flow diagram illustrating an exemplary method for upgrading an ebullated bed reactor to produce a vacuum residue product of improved quality while operating the reactor at similar or higher severity;

[0025] Figure 3B is a flow diagram illustrating an exemplary method for upgrading an ebullated bed reactor to produce a vacuum residue product of improved quality while operating the reactor at similar or higher throughput;

[0026] Figure 3C is a flow diagram illustrating an exemplary method for upgrading an ebullated bed reactor to produce a vacuum residue product of improved quality while operating the reactor at similar or higher conversion;

[0027] Figure 3D is a flow diagram illustrating an exemplary method for upgrading an ebullated bed reactor to produce a vacuum residue product of same or improved quality while operating the reactor at higher severity, throughput and/or conversion;

[0028] Figure 4 schematically illustrates an exemplary ebullated bed hydroprocessing system using a dual catalyst system including a heterogeneous catalyst and dispersed metal sulfide catalyst particles;

[0029] Figure 5 schematically illustrates a pilot scale ebullated bed hydroprocessing system configured to employ either a heterogeneous catalyst by itself or a dual catalyst system including a heterogeneous catalyst and dispersed metal sulfide catalyst particles;

[0030] Figure 6 is a line graph graphically representing differences in the Brookfield Viscosity (measured at 300°F (149°C)) of vacuum residue products having a boiling point of 1000°F+ (538°C+) produced when hydroprocessing a heavy oil feedstock (Ural vacuum residuum) using different dispersed metal sulfide catalyst particle concentrations and at different resid conversions according to Examples 1-6;

[0031] Figure 7 is a line graph graphically representing differences in the sulfur content of vacuum residue products having a boiling point of 1000°F+ (538°C+) produced when hydroprocessing Ural heavy oil feedstock using different dispersed metal sulfide catalyst particle concentrations and at different resid conversions according to Examples 1-6;

[0032] Figure 8 is a line graph graphically representing differences in the C₇ asphaltene content of vacuum residue products having a boiling point of 1000°F+ (538°C+) produced when hydroprocessing Ural heavy oil feedstock using different dispersed metal sulfide catalyst particle concentrations and at different resid conversions according to Examples 1-6;

[0033] Figure 9 is a line graph graphically representing differences in the carbon residue content (by MCR) of vacuum residue products having a boiling point of 1000°F+ (538°C+) produced when hydroprocessing Ural heavy oil feedstock using different dispersed metal sulfide catalyst particle concentrations and at different resid conversions according to Examples 1-6;

[0034] Figure 10 is a line graph graphically representing differences in the °API Gravity of vacuum residue products having a boiling point of 1000°F+ (538°C+) produced when hydroprocessing a heavy oil feedstock (Arab Medium vacuum residuum) using different dispersed metal sulfide catalyst particle concentrations and at different resid conversions according to Examples 7-13;

[0035] Figure 11 is a line graph graphically representing differences in the sulfur content of vacuum residue products having a boiling point of 1000°F+ (538°C+) produced when hydroprocessing Arab Medium heavy oil feedstock using different dispersed metal sulfide catalyst particle concentrations and at different resid conversions according to Examples 7-13;

[0036] Figure 12 is a line graph graphically representing differences in the Brookfield Viscosity (measured at 300°F (149°C)) of vacuum residue products having a boiling point of 1000°F+

(538°C+) produced when hydroprocessing Arab Medium heavy oil feedstock using different dispersed metal sulfide catalyst particle concentrations and at different resid conversions according to Examples 7-13;

[0037] Figure 13 is a line graph graphically representing differences in the °API Gravity of vacuum residue products having a boiling point of 975°F+ (524°C+) produced when hydroprocessing a heavy oil feedstock (Athabasca vacuum residuum) using different dispersed metal sulfide catalyst particle concentrations and at different resid conversions according to Examples 14-19;

[0038] Figure 14 is a line graph graphically representing differences in the sulfur content of vacuum residue products having a boiling point of 975°F+ (524°C+) produced when hydroprocessing Athabasca heavy oil feedstock using different dispersed metal sulfide catalyst particle concentrations and at different resid conversions according to Examples 14-19;

[0039] Figure 15 is a line graph graphically representing differences in the Brookfield Viscosity (measured at 300°F (149°C)) of vacuum residue products having a boiling point of 975°F+ (524°C+) produced when hydroprocessing Athabasca heavy oil feedstock using different dispersed metal sulfide catalyst particle concentrations and at different resid conversions according to Examples 16-19;

[0040] Figure 16 is a line graph graphically representing differences in the heptane insoluble content of vacuum residue products having a boiling point of 975°F+ (524°C+) produced when hydroprocessing Athabasca heavy oil feedstock using different dispersed metal sulfide catalyst particle concentrations and at different resid conversions according to Examples 16-19; and

[0041] Figure 17 is a line graph graphically representing differences in the carbon residue (MCR) content of vacuum residue products having a boiling point of 975°F+ (524°C+) produced when hydroprocessing Athabasca heavy oil feedstock using different dispersed metal sulfide catalyst particle concentrations and at different resid conversions according to Examples 16-19.

DETAILED DESCRIPTION OF THE PREFERRED EMBODIMENTS

I. INTRODUCTION AND DEFINITIONS

[0042] The present invention relates to methods and systems for using a dual catalyst system in an ebullated bed hydroprocessing system to produce converted hydrocarbon products from heavy oil and also vacuum residue products of improved quality. The methods and systems involve the

use of a dual catalyst system comprised of a solid supported (*i.e.*, heterogeneous) catalyst and well-dispersed (*e.g.*, homogeneous) catalyst particles. The dual catalyst system can be employed to upgrade an ebullated bed hydroprocessing system that otherwise utilizes a single catalyst composed of a solid supported ebullated bed catalyst.

[0043] By way of example, a method of upgrading an ebullated bed hydroprocessing system to produce converted products from heavy oil, including vacuum residue products of improved quality, comprises: (1) operating an ebullated bed reactor using a heterogeneous catalyst to hydroprocess heavy oil and produce converted products, including a vacuum residue product of initial quality; (2) thereafter upgrading the ebullated bed reactor to operate using a dual catalyst system comprised of dispersed metal sulfide catalyst particles and heterogeneous catalyst; and (3) operating the upgraded ebullated bed reactor to produce converted products, including a vacuum residue product of improved quality than when initially operating the ebullated bed reactor.

[0044] The term “heavy oil feedstock” shall refer to heavy crude, oil sands bitumen, bottom of the barrel and residuum left over from refinery processes (*e.g.*, visbreaker bottoms), and any other lower quality materials that contain a substantial quantity of high boiling hydrocarbon fractions and/or that include a significant quantity of asphaltenes that can deactivate a heterogeneous catalyst and/or cause or result in the formation of coke precursors and sediment. Examples of heavy oil feedstocks include, but are not limited to, Lloydminster heavy oil, Cold Lake bitumen, Athabasca bitumen, atmospheric tower bottoms, vacuum tower bottoms, residuum (or “resid”), resid pitch, vacuum residue (*e.g.*, Ural VR, Arab Medium VR, Athabasca VR, Cold Lake VR, Maya VR, and Chichimene VR), deasphalted liquids obtained by solvent deasphalting, asphaltene liquids obtained as a byproduct of deasphalting, and nonvolatile liquid fractions that remain after subjecting crude oil, bitumen from tar sands, liquefied coal, oil shale, or coal tar feedstocks to distillation, hot separation, solvent extraction, and the like. By way of further example, atmospheric tower bottoms (ATB) can have a nominal boiling point of at least 343°C (650°F) although it is understood that the cut point can vary among refineries and be as high as 380°C (716°F). Vacuum tower bottoms can have a nominal boiling point of at least 524°C (975°F), although it is understood that the cut point can vary among refineries and be as high as 538°C (1000°F) or even 565°C (1050°F).

[0045] The terms “asphaltene” and “asphaltenes” shall refer to materials in a heavy oil feedstock that are typically insoluble in paraffinic solvents such as propane, butane, pentane, hexane, and heptane. Asphaltenes can include sheets of condensed ring compounds held together by heteroatoms such as sulfur, nitrogen, oxygen and metals. Asphaltenes broadly include a wide range of complex compounds having anywhere from 80 to 1200 carbon atoms, with predominating molecular weights, as determined by solution techniques, in the 1200 to 16,900 range. About 80-90% of the metals in the crude oil are contained in the asphaltene fraction which, together with a higher concentration of non-metallic heteroatoms, renders the asphaltene molecules more hydrophilic and less hydrophobic than other hydrocarbons in crude. A hypothetical asphaltene molecule structure developed by A.G. Bridge and co-workers at Chevron is depicted in Figure 1. Generally, asphaltenes are typically defined based on the results of insolubles methods, and more than one definition of asphaltenes may be used. Specifically, a commonly used definition of asphaltenes is heptane insolubles minus toluene insolubles (*i.e.*, asphaltenes are soluble in toluene; sediments and residues insoluble in toluene are not counted as asphaltenes). Asphaltenes defined in this fashion may be referred to as “C₇ asphaltenes”. However, an alternate definition may also be used with equal validity, measured as pentane insolubles minus toluene insolubles, and commonly referred to as “C₅ asphaltenes”. In the examples of the present invention, the C₇ asphaltene definition is used, but the C₅ asphaltene definition can be readily substituted.

[0046] The terms “hydrocracking” and “hydroconversion” shall refer to a process whose primary purpose is to reduce the boiling range of a heavy oil feedstock and in which a substantial portion of the feedstock is converted into products with boiling ranges lower than that of the original feedstock. Hydrocracking or hydroconversion generally involves fragmentation of larger hydrocarbon molecules into smaller molecular fragments having a fewer number of carbon atoms and a higher hydrogen-to-carbon ratio. The mechanism by which hydrocracking occurs typically involves the formation of hydrocarbon free radicals during thermal fragmentation, followed by capping of the free radical ends or moieties with hydrogen. The hydrogen atoms or radicals that react with hydrocarbon free radicals during hydrocracking can be generated at or by active catalyst sites.

[0047] The term “hydrotreating” shall refer to operations whose primary purpose is to remove impurities such as sulfur, nitrogen, oxygen, halides, and trace metals from the feedstock and

saturate olefins and/or stabilize hydrocarbon free radicals by reacting them with hydrogen rather than allowing them to react with themselves. The primary purpose is not to change the boiling range of the feedstock. Hydrotreating is most often carried out using a fixed bed reactor, although other hydroprocessing reactors can also be used for hydrotreating, an example of which is an ebullated bed hydrotreater.

[0048] Of course, “hydrocracking” or “hydroconversion” may also involve the removal of sulfur and nitrogen from a feedstock as well as olefin saturation and other reactions typically associated with “hydrotreating”. The terms “hydroprocessing” and “hydroconversion” shall broadly refer to both “hydrocracking” and “hydrotreating” processes, which define opposite ends of a spectrum, and everything in between along the spectrum.

[0049] The term “hydrocracking reactor” shall refer to any vessel in which hydrocracking (*i.e.*, reducing the boiling range) of a feedstock in the presence of hydrogen and a hydrocracking catalyst is the primary purpose. Hydrocracking reactors are characterized as having an inlet port into which a heavy oil feedstock and hydrogen can be introduced, an outlet port from which an upgraded feedstock or material can be withdrawn, and sufficient thermal energy so as to form hydrocarbon free radicals in order to cause fragmentation of larger hydrocarbon molecules into smaller molecules. Examples of hydrocracking reactors include, but are not limited to, slurry phase reactors (*i.e.*, a two phase, gas-liquid system), ebullated bed reactors (*i.e.*, a three phase, gas-liquid-solid system), fixed bed reactors (*i.e.*, a three-phase system that includes a liquid feed trickling downward over or flowing upward through a fixed bed of solid heterogeneous catalyst with hydrogen typically flowing cocurrently, but possibly countercurrently, to the heavy oil).

[0050] The term “hydrocracking temperature” shall refer to a minimum temperature required to cause significant hydrocracking of a heavy oil feedstock. In general, hydrocracking temperatures will preferably fall within a range of about 399°C (750°F) to about 460°C (860°F), more preferably in a range of about 418°C (785°F) to about 443°C (830°F), and most preferably in a range of about 421°C (790°F) to about 440°C (825°F).

[0051] The term “gas-liquid slurry phase hydrocracking reactor” shall refer to a hydroprocessing reactor that includes a continuous liquid phase and a gaseous dispersed phase which forms a “slurry” of gaseous bubbles within the liquid phase. The liquid phase typically comprises a hydrocarbon feedstock that may contain a low concentration of dispersed metal sulfide catalyst particles, and the gaseous phase typically comprises hydrogen gas, hydrogen sulfide, and

vaporized low boiling point hydrocarbon products. The liquid phase can optionally include a hydrogen donor solvent. The term “gas-liquid-solid, 3-phase slurry hydrocracking reactor” is used when a solid catalyst is employed along with liquid and gas. The gas may contain hydrogen, hydrogen sulfide and vaporized low boiling hydrocarbon products. The term “slurry phase reactor” shall broadly refer to both type of reactors (*e.g.*, those with dispersed metal sulfide catalyst particles, those with a micron-sized or larger particulate catalyst, and those that include both).

[0052] The terms “solid heterogeneous catalyst”, “heterogeneous catalyst” and “supported catalyst” shall refer to catalysts typically used in ebullated bed and fixed bed hydroprocessing systems, including catalysts designed primarily for hydrocracking, hydroconversion, hydrodemetallization, and/or hydrotreating. A heterogeneous catalyst typically comprises: (i) a catalyst support having a large surface area and interconnected channels or pores; and (ii) fine active catalyst particles, such as sulfides of cobalt, nickel, tungsten, and molybdenum dispersed within the channels or pores. The pores of the support are typically of limited size to maintain mechanical integrity of the heterogeneous catalyst and prevent breakdown and formation of excessive fines in the reactor. Heterogeneous catalysts can be produced as cylindrical pellets, cylindrical extrudates, other shapes such as trilobes, rings, saddles, or the like, or spherical solids.

[0053] The terms “dispersed metal sulfide catalyst particles” and “dispersed catalyst” shall refer to catalyst particles having a particle size that is less than 1 μm *e.g.*, less than about 500 nm in diameter, or less than about 250 nm in diameter, or less than about 100 nm in diameter, or less than about 50 nm in diameter, or less than about 25 nm in diameter, or less than about 10 nm in diameter, or less than about 5 nm in diameter. The term “dispersed metal sulfide catalyst particles” may include molecular or molecularly-dispersed catalyst compounds. The term “dispersed metal sulfide catalyst particles” excludes metal sulfide particles and agglomerates of metal sulfide particles that are larger than 1 μm .

[0054] The term “molecularly-dispersed catalyst” shall refer to catalyst compounds that are essentially “dissolved” or dissociated from other catalyst compounds or molecules in a hydrocarbon feedstock or suitable diluent. It can include very small catalyst particles that contain a few catalyst molecules joined together (*e.g.*, 15 molecules or less).

[0055] The term “residual catalyst particles” shall refer to catalyst particles that remain with an upgraded material when transferred from one vessel to another (*e.g.*, from a hydroprocessing reactor to a separator and/or other hydroprocessing reactor).

[0056] The term “conditioned feedstock” shall refer to a hydrocarbon feedstock into which a catalyst precursor has been combined and mixed sufficiently so that, upon decomposition of the catalyst precursor and formation of the active catalyst, the catalyst will comprise dispersed metal sulfide catalyst particles formed *in situ* within the feedstock.

[0057] The terms “upgrade”, “upgrading” and “upgraded”, when used to describe a feedstock that is being or has been subjected to hydroprocessing, or a resulting material or product, shall refer to one or more of a reduction in the molecular weight of the feedstock, a reduction in the boiling point range of the feedstock, a reduction in the specific gravity of the feedstock, a reduction in the concentration of asphaltenes, a reduction in the concentration of hydrocarbon free radicals, and/or a reduction in the quantity of impurities, such as sulfur, nitrogen, oxygen, halides, and/or metals.

[0058] The term “severity” generally refers to the amount of energy that is introduced into heavy oil during hydroprocessing and is often related to the operating temperature of the hydroprocessing reactor (*i.e.*, higher temperature is related to higher severity; lower temperature is related to lower severity) in combination with the duration of said temperature exposure. Increased severity generally increases the quantity of conversion products produced by the hydroprocessing reactor, including both desirable products and undesirable conversion products. Desirable conversion products include hydrocarbons of reduced molecular weight, boiling point, and specific gravity, which can include end products such as naphtha, diesel, jet fuel, kerosene, wax, fuel oil, and the like. Other desirable conversion products include higher boiling hydrocarbons that can be further processed using conventional refining and/or distillation processes. Undesirable conversion products include coke, sediment, metals, and other solid materials that can deposit on hydroprocessing equipment and cause fouling, such as interior components of reactors, separators, filters, pipes, towers, heat exchangers, and the heterogeneous catalyst. Undesirable conversion products can also refer to unconverted resid that remains after distillation, such as atmospheric tower bottoms (“ATB”) or vacuum tower bottoms (“VTB”). Minimizing undesirable conversion products reduces equipment fouling and shutdowns required to clean the equipment. Nevertheless, there may be a desirable amount of unconverted resid in

order for downstream separation equipment to function properly and/or in order to provide a liquid transport medium for containing coke, sediment, metals, and other solid materials that might otherwise deposit on and foul equipment but that can be transported away by the remaining resid.

[0059] Unconverted residues can also be useful products, such as fuel oil and asphalt for building roads. When residues are used for fuel oil, the quality of the fuel can be measured by one or more properties such as viscosity, specific gravity, asphaltene content, carbon content, sulfur content, and sediment, with lower values of each generally corresponding to higher quality fuel oil. For example, a vacuum residue designated for use as fuel oil will be of higher quality when the viscosity is lower (*e.g.*, because it will require less cutter stock (*e.g.*, vacuum gas oil or cycle oil) in order to flow and be handled). Similarly, a reduction in the sulfur content of vacuum residue requires less dilution using higher value cutter stocks to meet specifications for maximum sulfur content. Reductions in asphaltene, sediment, and/or carbon content can improve stability of the fuel oil.

[0060] In addition to temperature, “severity” can be related to one or both of “conversion” and “throughput”. Whether increased severity involves increased conversion and/or increased or decreased throughput may depend on the quality of the heavy oil feedstock and/or the mass balance of the overall hydroprocessing system. For example, where it is desired to convert a greater quantity of feed material and/or provide a greater quantity of material to downstream equipment, increased severity may primarily involve increased throughput without necessarily increasing fractional conversion. This can include the case where resid fractions (ATB and/or VTB) are sold as fuel oil and increased conversion without increased throughput might decrease the quantity of this product. In the case where it is desired to increase the ratio of upgraded materials to resid fractions, it may be desirable to primarily increase conversion without necessarily increasing throughput. Where the quality of heavy oil introduced into the hydroprocessing reactor fluctuates, it may be desirable to selectively increase or decrease one or both of conversion and throughput to maintain a desired ratio of upgraded materials to resid fractions and/or a desired absolute quantity or quantities of end product(s) being produced.

[0061] The terms “conversion” and “fractional conversion” refer to the proportion, often expressed as a percentage, of heavy oil that is beneficially converted into lower boiling and/or lower molecular weight materials. The conversion is expressed as a percentage of the initial resid

content (i.e. components with boiling point greater than a defined residue cut point) which is converted to products with boiling point less than the defined cut point. The definition of residue cut point can vary, and can nominally include 524°C (975°F), 538°C (1000°F), 565°C (1050°F), and the like. It can be measured by distillation analysis of feed and product streams to determine the concentration of components with boiling point greater than the defined cut point. Fractional conversion is expressed as $(F-P)/F$, where F is the quantity of resid in the combined feed streams, and P is the quantity in the combined product streams, where both feed and product resid content are based on the same cut point definition. The quantity of resid is most often defined based on the mass of components with boiling point greater than the defined cut point, but volumetric or molar definitions could also be used.

[0062] The term “throughput” refers to the quantity of feed material that is introduced into the hydroprocessing reactor as a function of time. It is also related to the total quantity of conversion products removed from the hydroprocessing reactor, including the combined amounts of desirable and undesirable products. Throughput can be expressed in volumetric terms, such as barrels per day, or in mass terms, such as metric tons per hour. In common usage, throughput is defined as the mass or volumetric feed rate of only the heavy oil feedstock itself (for example, vacuum tower bottoms or the like). The definition does not normally include quantities of diluents or other components that may sometimes be included in the overall feeds to a hydroconversion unit, although a definition which includes those other components could also be used.

[0063] The term “sediment” refers to solids formed in a liquid stream that can settle out. Sediments can include inorganics, coke, or insoluble asphaltenes that precipitate after conversion. Sediment in petroleum products is commonly measured using the IP-375 hot filtration test procedure for total sediment in residual fuel oils published as part of ISO 10307 and ASTM D4870. Other tests include the IP-390 sediment test and the Shell hot filtration test. Sediment is related to components of the oil that have a propensity for forming solids during processing and handling. These solid-forming components have multiple undesirable effects in a hydroconversion process, including degradation of product quality and operability problems related to equipment fouling. It should be noted that although the strict definition of sediment is based on the measurement of solids in a sediment test, it is common for the term to be used more

loosely to refer to the solids-forming components of the oil itself, which may not be present in the oil as actual solids, but which contribute to solids formation under certain conditions.

[0064] The term “fouling” refers to the formation of an undesirable phase (foulant) that interferes with processing. The foulant is normally a carbonaceous material or solid that deposits and collects within the processing equipment. Equipment fouling can result in loss of production due to equipment shutdown, decreased performance of equipment, increased energy consumption due to the insulating effect of foulant deposits in heat exchangers or heaters, increased maintenance costs for equipment cleaning, reduced efficiency of fractionators, and reduced reactivity of heterogeneous catalyst.

II. EBULLATED BED HYDROPROCESSING REACTORS AND SYSTEMS

[0065] Figures 2A-2D schematically depict non-limiting examples of ebullated bed hydroprocessing reactors and systems used to hydroprocess hydrocarbon feedstocks such as heavy oil, which can be upgraded to use a dual catalyst system according to the invention. It will be appreciated that the example ebullated bed hydroprocessing reactors and systems can include interstage separation, integrated hydrotreating, and/or integrated hydrocracking.

[0066] Figure 2A schematically illustrates an ebullated bed hydroprocessing reactor 10 used in the LC-Fining hydrocracking system developed by C-E Lummus. Ebullated bed reactor 10 includes an inlet port 12 near the bottom, through which a feedstock 14 and pressurized hydrogen gas 16 are introduced, and an outlet port 18 at the top, through which hydroprocessed material 20 is withdrawn.

[0067] Reactor 10 further includes an expanded catalyst zone 22 comprising a heterogeneous catalyst 24 that is maintained in an expanded or fluidized state against the force of gravity by upward movement of liquid hydrocarbons and gas (schematically depicted as bubbles 25) through ebullated bed reactor 10. The lower end of expanded catalyst zone 22 is defined by a distributor grid plate 26, which separates expanded catalyst zone 22 from a lower heterogeneous catalyst free zone 28 located between the bottom of ebullated bed reactor 10 and distributor grid plate 26. Distributor grid plate 26 is configured to distribute the hydrogen gas and hydrocarbons evenly across the reactor and prevents heterogeneous catalyst 24 from falling by the force of gravity into lower heterogeneous catalyst free zone 28. The upper end of the expanded catalyst zone 22 is the height at which the downward force of gravity begins to equal or exceed the uplifting force of the upwardly moving feedstock and gas through ebullated bed reactor 10 as

heterogeneous catalyst 24 reaches a given level of expansion or separation. Above expanded catalyst zone 22 is an upper heterogeneous catalyst free zone 30.

[0068] Hydrocarbons and other materials within the ebullated bed reactor 10 are continuously recirculated from upper heterogeneous catalyst free zone 30 to lower heterogeneous catalyst free zone 28 by means of a recycling channel 32 positioned in the center of ebullated bed reactor 10 connected to an ebullating pump 34 at the bottom of ebullated bed reactor 10. At the top of recycling channel 32 is a funnel-shaped recycle cup 36 through which feedstock is drawn from upper heterogeneous catalyst free zone 30. Material drawn downward through recycling channel 32 enters lower catalyst free zone 28 and then passes upwardly through distributor grid plate 26 and into expanded catalyst zone 22, where it is blended with freshly added feedstock 14 and hydrogen gas 16 entering ebullated bed reactor 10 through inlet port 12. Continuously circulating blended materials upward through the ebullated bed reactor 10 advantageously maintains heterogeneous catalyst 24 in an expanded or fluidized state within expanded catalyst zone 22, minimizes channeling, controls reaction rates, and keeps heat released by the exothermic hydrogenation reactions to a safe level.

[0069] Fresh heterogeneous catalyst 24 is introduced into ebullated bed reactor 10, such as expanded catalyst zone 22, through a catalyst inlet tube 38, which passes through the top of ebullated bed reactor 10 and directly into expanded catalyst zone 22. Spent heterogeneous catalyst 24 is withdrawn from expanded catalyst zone 22 through a catalyst withdrawal tube 40 that passes from a lower end of expanded catalyst zone 22 through distributor grid plate 26 and the bottom of ebullated bed reactor 10. It will be appreciated that the catalyst withdrawal tube 40 is unable to differentiate between fully spent catalyst, partially spent but active catalyst, and freshly added catalyst such that a random distribution of heterogeneous catalyst 24 is typically withdrawn from ebullated bed reactor 10 as “spent” catalyst.

[0070] Upgraded material 20 withdrawn from ebullated bed reactor 10 can be introduced into a separator 42 (*e.g.*, hot separator, inter-stage pressure differential separator, or distillation tower, such as atmospheric or vacuum). The separator 42 separates one or more volatile fractions 46 from a non-volatile fraction 48.

[0071] Figure 2B schematically illustrates an ebullated bed reactor 110 used in the H-Oil hydrocracking system developed by Hydrocarbon Research Incorporated and currently licensed by Axens. Ebullated bed reactor 110 includes an inlet port 112, through which a heavy oil

feedstock 114 and pressurized hydrogen gas 116 are introduced, and an outlet port 118, through which upgraded material 120 is withdrawn. An expanded catalyst zone 122 comprising a heterogeneous catalyst 124 is bounded by a distributor grid plate 126, which separates expanded catalyst zone 122 from a lower catalyst free zone 128 between the bottom of reactor 110 and distributor grid plate 126, and an upper end 129, which defines an approximate boundary between expanded catalyst zone 122 and an upper catalyst free zone 130. Dotted boundary line 131 schematically illustrates the approximate level of heterogeneous catalyst 124 when not in an expanded or fluidized state.

[0072] Materials are continuously recirculated within reactor 110 by a recycling channel 132 connected to an ebullating pump 134 positioned outside of reactor 110. Materials are drawn through a funnel-shaped recycle cup 136 from upper catalyst free zone 130. Recycle cup 136 is spiral-shaped, which helps separate hydrogen bubbles 125 from recycles material 132 to prevent cavitation of ebullating pump 134. Recycled material 132 enters lower catalyst free zone 128, where it is blended with fresh feedstock 116 and hydrogen gas 118, and the mixture passes up through distributor grid plate 126 and into expanded catalyst zone 122. Fresh catalyst 124 is introduced into expanded catalyst zone 122 through a catalyst inlet tube 136, and spent catalyst 124 is withdrawn from expanded catalyst zone 122 through a catalyst discharge tube 140.

[0073] The main difference between the H-Oil ebullated bed reactor 110 and the LC-Fining ebullated bed reactor 10 is the location of the ebullating pump. Ebullating pump 134 in H-Oil reactor 110 is located external to the reaction chamber. The recirculating feedstock is introduced through a recirculation port 141 at the bottom of reactor 110. The recirculation port 141 includes a distributor 143, which aids in evenly distributing materials through lower catalyst free zone 128. Upgraded material 120 is shown being sent to a separator 142, which separates one or more volatile fractions 146 from a non-volatile fraction 148.

[0074] Figure 2C schematically illustrates an ebullated bed hydroprocessing system 200 comprising multiple ebullated bed reactors. Hydroprocessing system 200, an example of which is an LC-Fining hydroprocessing unit, may include three ebullated bed reactors 210 in series for upgrading a feedstock 214. Feedstock 214 is introduced into a first ebullated bed reactor 210a together with hydrogen gas 216, both of which are passed through respective heaters prior to entering the reactor. Upgraded material 220a from first ebullated bed reactor 210a is introduced together with additional hydrogen gas 216 into a second ebullated bed reactor 210b. Upgraded

material 220b from second ebullated bed reactor 210b is introduced together with additional hydrogen gas 216 into a third ebullated bed reactor 210c.

[0075] It should be understood that one or more interstage separators can optionally be interposed between first and second reactors 210a, 210b and/or second and third reactors 210b, 210c, in order to remove lower boiling fractions and gases from a non-volatile fraction containing liquid hydrocarbons and residual dispersed metal sulfide catalyst particles. It can be desirable to remove lower alkanes, such as hexanes and heptanes, which are valuable fuel products but poor solvents for asphaltenes. Removing volatile materials between multiple reactors enhances production of valuable products and increases the solubility of asphaltenes in the hydrocarbon liquid fraction fed to the downstream reactor(s). Both increase efficiency of the overall hydroprocessing system.

[0076] Upgraded material 220c from third ebullated bed reactor 210c is sent to a high temperature separator 242a, which separates volatile and non-volatile fractions. Volatile fraction 246a passes through a heat exchanger 250, which preheats hydrogen gas 216 prior to being introduced into first ebullated bed reactor 210a. The somewhat cooled volatile fraction 246a is sent to a medium temperature separator 242b, which separates a remaining volatile fraction 246b from a resulting liquid fraction 248b that forms as a result of cooling by heat exchanger 250. Remaining volatile fraction 246b is sent downstream to a low temperature separator 246c for further separation into a gaseous fraction 252c and a degassed liquid fraction 248c.

[0077] A liquid fraction 248a from high temperature separator 242a is sent together with resulting liquid fraction 248b from medium temperature separator 242b to a low pressure separator 242d, which separates a hydrogen rich gas 252d from a degassed liquid fraction 248d, which is then mixed with the degassed liquid fraction 248c from low temperature separator 242c and fractionated into products. Gaseous fraction 252c from low temperature separator 242c is purified into off gas, purge gas, and hydrogen gas 216. Hydrogen gas 216 is compressed, mixed with make-up hydrogen gas 216a, and either passed through heat exchanger 250 and introduced into first ebullated bed reactor 210a together with feedstock 216 or introduced directly into second and third ebullated bed reactors 210b and 210c.

[0078] Figure 2D schematically illustrates an ebullated bed hydroprocessing system 200 comprising multiple ebullated bed reactors, similar to the system illustrated in Figure 2C, but showing an interstage separator 221 interposed between second and third reactors 210b, 210c

(although interstage separator 221 may be interposed between first and second reactors 210a, 210b). As illustrated, the effluent from second-stage reactor 210b enters interstage separator 221, which can be a high-pressure, high-temperature separator. The liquid fraction from separator 221 is combined with a portion of the recycle hydrogen from line 216 and then enters third-stage reactor 210c. The vapor fraction from the interstage separator 221 bypasses third-stage reactor 210c, mixes with effluent from third-stage reactor 210c, and then passes into a high-pressure, high-temperature separator 242a.

[0079] This allows lighter, more-saturated components formed in the first two reactor stages to bypass third-stage reactor 210c. The benefits of this are (1) a reduced vapor load on the third-stage reactor, which increases the volume utilization of the third-stage reactor for converting the remaining heavy components, and (2) a reduced concentration of “anti-solvent” components (saturates) which can destabilize asphaltenes in third-stage reactor 210c.

[0080] In preferred embodiments, the hydroprocessing systems are configured and operated to promote hydrocracking reactions rather than mere hydrotreating, which is a less severe form of hydroprocessing. Hydrocracking involves the breaking of carbon-carbon molecular bonds, such as reducing the molecular weight of larger hydrocarbon molecules and/or ring opening of aromatic compounds. Hydrotreating, on the other hand, mainly involves hydrogenation of unsaturated hydrocarbons, with minimal or no breaking of carbon-carbon molecular bonds. To promote hydrocracking rather than mere hydrotreating reactions, the hydroprocessing reactor(s) are preferably operated at a temperature in a range of about 750°F (399°C) to about 860°F (460°C), more preferably in a range of about 780°F (416°C) to about 830°F (443°C), are preferably operated at a pressure in a range of about 1000 psig (6.9 MPa) to about 3000 psig (20.7 MPa), more preferably in a range of about 1500 psig (10.3 MPa) to about 2500 psig (17.2 MPa), and are preferably operated at a space velocity (*e.g.*, Liquid Hourly Space Velocity, or LHSV, defined as the ratio of feed volume to reactor volume per hour) in a range of about 0.05 hr⁻¹ to about 0.45 hr⁻¹, more preferably in a range of about 0.15 hr⁻¹ to about 0.35 hr⁻¹. The difference between hydrocracking and hydrotreating can also be expressed in terms of resid conversion (wherein hydrocracking results in the substantial conversion of higher boiling to lower boiling hydrocarbons, while hydrotreating does not). The hydroprocessing systems disclosed herein can result in a resid conversion in a range of about 40% to about 90%, preferably in a range of about 55% to about 80%. The preferred conversion range typically

depends on the type of feedstock because of differences in processing difficulty between different feedstocks. Typically, conversion will be at least about 5% higher, preferably at least about 10% higher, compared to operating an ebullated bed reactor prior to upgrading to utilize a dual catalyst system as disclosed herein.

III. UPGRADING AN EBULLATED BED HYDROPROCESSING REACTOR

[0081] Figures 3A, 3B, 3C, and 3D are flow diagrams which illustrate exemplary methods for upgrading an ebullated bed reactor to use a dual catalyst system and produce vacuum residue products of improved quality (*e.g.*, as measured by one or more of reduced viscosity, reduced specific gravity, reduced asphaltene content, reduced carbon content, reduced sulfur content, and reduced sediment content).

[0082] Figure 3A is a flow diagram that illustrates a method comprising: (1) initially operating an ebullated bed reactor to hydroprocess heavy oil using a heterogeneous catalyst at initial conditions and producing vacuum residue of initial quality; (2) adding dispersed metal sulfide catalyst particles to the ebullated bed reactor to form an upgraded reactor with a dual catalyst system including a heterogeneous catalyst and the dispersed metal sulfide catalyst particles; and (3) operating the upgraded ebullated bed reactor using the dual catalyst system at similar or higher severity and producing a vacuum residue product of improved quality than when operating at the initial conditions.

[0083] According to some embodiments, the heterogeneous catalyst utilized when initially operating the ebullated bed reactor at an initial condition is a commercially available catalyst that is typically used in ebullated bed reactors. To maximize efficiency, the initial reactor conditions may advantageously be at a reactor severity at which sediment formation and fouling are maintained within acceptable levels. Increasing reactor severity without upgrading the ebullated reactor to use a dual catalyst system may therefore result in excessive sediment formation and undesirable equipment fouling, which would otherwise require more frequent shutdown and cleaning of the hydroprocessing reactor and related equipment, such as pipes, towers, heaters, heterogeneous catalyst and/or separation equipment.

[0084] In order to improve the quality of vacuum residue produced while operating the ebullated bed reactor at similar or increased severity, the ebullated bed reactor is upgraded to use a dual catalyst system comprising a heterogeneous catalyst and dispersed metal sulfide catalyst particles. Vacuum residue products of improved quality are characterized by one or more of

reduced viscosity, reduced specific gravity, reduced asphaltene content, reduced carbon content, reduced sulfur content, and reduced sediment.

[0085] Figure 3B is a flow diagram that illustrates a method comprising: (1) initially operating an ebullated bed reactor to hydroprocess heavy oil using a heterogeneous catalyst at initial conditions and producing vacuum residue of initial quality; (2) adding dispersed metal sulfide catalyst particles to the ebullated bed reactor to form an upgraded reactor with a dual catalyst system including a heterogeneous catalyst and the dispersed metal sulfide catalyst particles; and (3) operating the upgraded ebullated bed reactor using the dual catalyst system at similar or higher throughput and producing a vacuum residue product of improved quality than when operating at the initial conditions.

[0086] Figure 3C is a flow diagram that illustrates a method comprising: (1) initially operating an ebullated bed reactor to hydroprocess heavy oil using a heterogeneous catalyst at initial conditions and producing vacuum residue of initial quality; (2) adding dispersed metal sulfide catalyst particles to the ebullated bed reactor to form an upgraded reactor with a dual catalyst system including a heterogeneous catalyst and the dispersed metal sulfide catalyst particles; and (3) operating the upgraded ebullated bed reactor using the dual catalyst system at similar or higher conversion and producing a vacuum residue product of improved quality than when operating at the initial conditions.

[0087] Figure 3D is a flow diagram that illustrates a method comprising: (1) initially operating an ebullated bed reactor to hydroprocess heavy oil using a heterogeneous catalyst at initial conditions and producing vacuum residue of initial quality; (2) adding dispersed metal sulfide catalyst particles to the ebullated bed reactor to form an upgraded reactor with a dual catalyst system including a heterogeneous catalyst and the dispersed metal sulfide catalyst particles; and (3) operating the upgraded ebullated bed reactor using the dual catalyst system at higher severity, throughput and/or conversion and producing a vacuum residue product of same or improved quality than when operating at the initial conditions.

[0088] The dispersed metal sulfide catalyst particles can be generated separately and then added to the ebullated bed reactor when forming the dual catalyst system. Alternatively or in addition, at least a portion of the dispersed metal sulfide catalyst particles can be generated *in situ* in the heavy oil within the ebullated bed reactor.

[0089] In some embodiments, the dispersed metal sulfide catalyst particles are advantageously formed *in situ* within an entirety of a heavy oil feedstock. This can be accomplished by initially mixing a catalyst precursor with an entirety of the heavy oil feedstock to form a conditioned feedstock and thereafter heating the conditioned feedstock to decompose the catalyst precursor and cause or allow catalyst metal to react with sulfur and/or sulfur-containing molecules in and/or added to the heavy oil to form the dispersed metal sulfide catalyst particles.

[0090] The catalyst precursor can be oil soluble and have a decomposition temperature in a range from about 100°C (212°F) to about 350°C (662°F), or in a range of about 150°C (302°F) to about 300°C (572°F), or in a range of about 175°C (347°F) to about 250°C (482°F). Example catalyst precursors include organometallic complexes or compounds, more specifically oil soluble compounds or complexes of transition metals and organic acids, having a decomposition temperature or range high enough to avoid substantial decomposition when mixed with a heavy oil feedstock under suitable mixing conditions. When mixing the catalyst precursor with a hydrocarbon oil diluent, it is advantageous to maintain the diluent at a temperature below which significant decomposition of the catalyst precursor occurs. One of skill in the art can, following the present disclosure, select a mixing temperature profile that results in intimate mixing of a selected precursor composition without substantial decomposition prior to formation of the dispersed metal sulfide catalyst particles.

[0091] Example catalyst precursors include, but are not limited to, molybdenum 2-ethylhexanoate, molybdenum octoate, molybdenum naphthanate, vanadium naphthanate, vanadium octoate, molybdenum hexacarbonyl, vanadium hexacarbonyl, and iron pentacarbonyl. Other catalyst precursors include molybdenum salts comprising a plurality of cationic molybdenum atoms and a plurality of carboxylate anions of at least 8 carbon atoms and that are at least one of (a) aromatic, (b) alicyclic, or (c) branched, unsaturated and aliphatic. By way of example, each carboxylate anion may have between 8 and 17 carbon atoms or between 11 and 15 carbon atoms. Examples of carboxylate anions that fit at least one of the foregoing categories include carboxylate anions derived from carboxylic acids selected from the group consisting of 3-cyclopentylpropionic acid, cyclohexanebutyric acid, biphenyl-2-carboxylic acid, 4-heptylbenzoic acid, 5-phenylvaleric acid, geranic acid (3,7-dimethyl-2,6-octadienoic acid), and combinations thereof.

[0092] In other embodiments, carboxylate anions for use in making oil soluble, thermally stable, molybdenum catalyst precursor compounds are derived from carboxylic acids selected from the group consisting of 3-cyclopentylpropionic acid, cyclohexanebutyric acid, biphenyl-2-carboxylic acid, 4-heptylbenzoic acid, 5-phenylvaleric acid, geranic acid (3,7-dimethyl-2,6-octadienoic acid), 10-undecenoic acid, dodecanoic acid, and combinations thereof. It has been discovered that molybdenum catalyst precursors made using carboxylate anions derived from the foregoing carboxylic acids possess improved thermal stability.

[0093] Catalyst precursors with higher thermal stability can have a first decomposition temperature higher than 210°C, higher than about 225°C, higher than about 230°C, higher than about 240°C, higher than about 275°C, or higher than about 290°C. Such catalyst precursors can have a peak decomposition temperature higher than 250°C, or higher than about 260°C, or higher than about 270°C, or higher than about 280°C, or higher than about 290°C, or higher than about 330°C.

[0094] One of skill in the art can, following the present disclosure, select a mixing temperature profile that results in intimate mixing of a selected precursor composition without substantial decomposition prior to formation of the dispersed metal sulfide catalyst particles.

[0095] Whereas it is within the scope of the invention to directly blend the catalyst precursor composition with the heavy oil feedstock, care must be taken in such cases to mix the components for a time sufficient to thoroughly blend the precursor composition within the feedstock before substantial decomposition of the precursor composition has occurred. For example, U.S. Patent No. 5,578,197 to Cyr et al. describes a method whereby molybdenum 2-ethyl hexanoate was mixed with bitumen vacuum tower residuum for 24 hours before the resulting mixture was heated in a reaction vessel to form the catalyst compound and to effect hydrocracking (*see* col. 10, lines 4-43). Whereas 24-hour mixing in a testing environment may be entirely acceptable, such long mixing times may make certain industrial operations prohibitively expensive. To ensure thorough mixing of the catalyst precursor within the heavy oil prior to heating to form the active catalyst, a series of mixing steps are performed by different mixing apparatus prior to heating the conditioned feedstock. These may include one or more low shear in-line mixers, followed by one or more high shear mixers, followed by a surge vessel and pump-around system, followed by one or more multi-stage high pressure pumps used to pressurize the feed stream prior to introducing it into a hydroprocessing reactor.

[0096] In some embodiments, the conditioned feedstock is pre-heated using a heating apparatus prior to entering the hydroprocessing reactor in order to form at least a portion of the dispersed metal sulfide catalyst particles *in situ* within the heavy oil. In other embodiments, the conditioned feedstock is heated or further heated in the hydroprocessing reactor in order to form at least a portion of the dispersed metal sulfide catalyst particles *in situ* within the heavy oil.

[0097] In some embodiments, the dispersed metal sulfide catalyst particles can be formed in a multi-step process. For example, an oil soluble catalyst precursor composition can be pre-mixed with a hydrocarbon diluent to form a diluted precursor mixture. Examples of suitable hydrocarbon diluents include, but are not limited to, vacuum gas oil (which typically has a nominal boiling range of 360-524°C) (680-975°F), decant oil or cycle oil (which typically has a nominal boiling range of 360°-550°C) (680-1022°F), and gas oil (which typically has a nominal boiling range of 200°-360°C) (392-680 °F), a portion of the heavy oil feedstock, and other hydrocarbons that nominally boil at a temperature higher than about 200°C.

[0098] The ratio of catalyst precursor to hydrocarbon oil diluent used to make the diluted precursor mixture can be in a range of about 1:500 to about 1:1, or in a range of about 1:150 to about 1:2, or in a range of about 1:100 to about 1:5 (*e.g.*, 1:100, 1:50, 1:30, or 1:10).

[0099] The amount of catalyst metal (*e.g.*, molybdenum) in the diluted precursor mixture is preferably in a range of about 100 ppm to about 7000 ppm by weight of the diluted precursor mixture, more preferably in a range of about 300 ppm to about 4000 ppm by weight of the diluted precursor mixture.

[0100] The catalyst precursor is advantageously mixed with the hydrocarbon diluent below a temperature at which a significant portion of the catalyst precursor composition decomposes. The mixing may be performed at temperature in a range of about 25 °C (77 °F) to about 250 °C (482 °F), or in range of about 50 °C (122 °F) to about 200 °C (392 °F), or in a range of about 75 °C (167 °F) to about 150 °C (302 °F), to form the diluted precursor mixture. The temperature at which the diluted precursor mixture is formed may depend on the decomposition temperature and/or other characteristics of the catalyst precursor that is utilized and/or characteristics of the hydrocarbon diluent, such as viscosity.

[0101] The catalyst precursor is preferably mixed with the hydrocarbon oil diluent for a time period in a range of about 0.1 second to about 5 minutes, or in a range of about 0.5 second to about 3 minutes, or in a range of about 1 second to about 1 minute. The actual mixing time is

dependent, at least in part, on the temperature (*i.e.*, which affects the viscosity of the fluids) and mixing intensity. Mixing intensity is dependent, at least in part, on the number of stages *e.g.*, for an in-line static mixer.

[0102] Pre-blending the catalyst precursor with a hydrocarbon diluent to form a diluted precursor mixture which is then blended with the heavy oil feedstock greatly aids in thoroughly and intimately blending the catalyst precursor within the feedstock, particularly in the relatively short period of time required for large-scale industrial operations. Forming a diluted precursor mixture shortens the overall mixing time by (1) reducing or eliminating differences in solubility between a more polar catalyst precursor and a more hydrophobic heavy oil feedstock, (2) reducing or eliminating differences in rheology between the catalyst precursor and heavy oil feedstock, and/or (3) breaking up catalyst precursor molecules to form a solute within the hydrocarbon diluent that is more easily dispersed within the heavy oil feedstock.

[0103] The diluted precursor mixture is then combined with the heavy oil feedstock and mixed for a time sufficient and in a manner so as to disperse the catalyst precursor throughout the feedstock to form a conditioned feedstock in which the catalyst precursor is thoroughly mixed within the heavy oil prior to thermal decomposition and formation of the active metal sulfide catalyst particles. In order to obtain sufficient mixing of the catalyst precursor within the heavy oil feedstock, the diluted precursor mixture and heavy oil feedstock are advantageously mixed for a time period in a range of about 0.1 second to about 5 minutes, or in a range from about 0.5 second to about 3 minutes, or in a range of about 1 second to about 3 minutes. Increasing the vigorousness and/or shearing energy of the mixing process generally reduce the time required to effect thorough mixing.

[0104] Examples of mixing apparatus that can be used to effect thorough mixing of the catalyst precursor and/or diluted precursor mixture with heavy oil include, but are not limited to, high shear mixing such as mixing created in a vessel with a propeller or turbine impeller; multiple static in-line mixers; multiple static in-line mixers in combination with in-line high shear mixers; multiple static in-line mixers in combination with in-line high shear mixers followed by a surge vessel; combinations of the above followed by one or more multi-stage centrifugal pumps; and one or more multi-stage centrifugal pumps. According some embodiments, continuous rather than batch-wise mixing can be carried out using high energy pumps having multiple chambers within which the catalyst precursor composition and heavy oil feedstock are churned and mixed

as part of the pumping process itself. The foregoing mixing apparatus may also be used for the pre-mixing process discussed above in which the catalyst precursor is mixed with the hydrocarbon diluent to form the catalyst precursor mixture.

[0105] In the case of heavy oil feedstocks that are solid or extremely viscous at room temperature, such feedstocks may advantageously be heated in order to soften them and create a feedstock having sufficiently low viscosity so as to allow good mixing of the oil soluble catalyst precursor into the feedstock composition. In general, decreasing the viscosity of the heavy oil feedstock will reduce the time required to effect thorough and intimate mixing of the oil soluble precursor composition within the feedstock.

[0106] The heavy oil feedstock and catalyst precursor and/or diluted precursor mixture are advantageously mixed at a temperature in a range of about 25°C (77°F) to about 350°C (662°F), or in a range of about 50°C (122°F) to about 300°C (572°F), or in a range of about 75°C (167°F) to about 250°C (482°F) to yield a conditioned feedstock.

[0107] In the case where the catalyst precursor is mixed directly with the heavy oil feedstock without first forming a diluted precursor mixture, it may be advantageous to mix the catalyst precursor and heavy oil feedstock below a temperature at which a significant portion of the catalyst precursor composition decomposes. However, in the case where the catalyst precursor is premixed with a hydrocarbon diluent to form a diluted precursor mixture, which is thereafter mixed with the heavy oil feedstock, it may be permissible for the heavy oil feedstock to be at or above the decomposition temperature of the catalyst precursor. That is because the hydrocarbon diluent shields the individual catalyst precursor molecules and prevents them from agglomerating to form larger particles, temporarily insulates the catalyst precursor molecules from heat from the heavy oil during mixing, and facilitates dispersion of the catalyst precursor molecules sufficiently quickly throughout the heavy oil feedstock before decomposing to liberate metal. In addition, additional heating of the feedstock may be necessary to liberate hydrogen sulfide from sulfur-bearing molecules in the heavy oil to form the metal sulfide catalyst particles. In this way, progressive dilution of the catalyst precursor permits a high level of dispersion within the heavy oil feedstock, resulting in the formation of highly dispersed metal sulfide catalyst particles, even where the feedstock is at a temperature above the decomposition temperature of the catalyst precursor.

[0108] After the catalyst precursor has been well-mixed throughout the heavy oil to yield a conditioned feedstock, this composition is then heated to cause decomposition of the catalyst precursor to liberate catalyst metal therefrom, cause or allow it to react with sulfur within and/or added to the heavy oil, and form the active metal sulfide catalyst particles. Metal from the catalyst precursor may initially form a metal oxide, which then reacts with sulfur in the heavy oil to yield a metal sulfide compound that forms the final active catalyst. In the case where the heavy oil feedstock includes sufficient or excess sulfur, the final activated catalyst may be formed *in situ* by heating the heavy oil feedstock to a temperature sufficient to liberate sulfur therefrom. In some cases, sulfur may be liberated at the same temperature that the precursor composition decomposes. In other cases, further heating to a higher temperature may be required.

[0109] If the catalyst precursor is thoroughly mixed throughout the heavy oil, at least a substantial portion of the liberated metal ions will be sufficiently sheltered or shielded from other metal ions so that they can form a molecularly-dispersed catalyst upon reacting with sulfur to form the metal sulfide compound. Under some circumstances, minor agglomeration may occur, yielding colloidal-sized catalyst particles. However, it is believed that taking care to thoroughly mix the catalyst precursor throughout the feedstock prior to thermal decomposition of the catalyst precursor may yield individual catalyst molecules rather than colloidal particles. Simply blending, while failing to sufficiently mix, the catalyst precursor with the feedstock typically causes formation of large agglomerated metal sulfide compounds that are micron-sized or larger.

[0110] In order to form dispersed metal sulfide catalyst particles, the conditioned feedstock is heated to a temperature in a range of about 275°C (527°F) to about 450°C (842°F), or in a range of about 310°C (590°F) to about 430°C (806°F), or in a range of about 330°C (626°F) to about 410°C (770°F).

[0111] The initial concentration of catalyst metal provided by dispersed metal sulfide catalyst particles can be in a range of about 1 ppm to about 500 ppm by weight of the heavy oil feedstock, or in a range of about 5 ppm to about 300 ppm, or in a range of about 10 ppm to about 100 ppm. The catalyst may become more concentrated as volatile fractions are removed from a resid fraction.

[0112] In the case where the heavy oil feedstock includes a significant quantity of asphaltene molecules, the dispersed metal sulfide catalyst particles may preferentially associate with, or

remain in close proximity to, the asphaltene molecules. Asphaltene molecules can have a greater affinity for the metal sulfide catalyst particles since asphaltene molecules are generally more hydrophilic and less hydrophobic than other hydrocarbons contained within heavy oil. Because the metal sulfide catalyst particles tend to be very hydrophilic, the individual particles or molecules will tend to migrate toward more hydrophilic moieties or molecules within the heavy oil feedstock.

[0113] While the highly polar nature of metal sulfide catalyst particles causes or allows them to associate with asphaltene molecules, it is the general incompatibility between the highly polar catalyst compounds and hydrophobic heavy oil that necessitates the aforementioned intimate or thorough mixing of catalyst precursor composition within the heavy oil prior to decomposition and formation of the active catalyst particles. Because metal catalyst compounds are highly polar, they cannot be effectively dispersed within heavy oil if added directly thereto. In practical terms, forming smaller active catalyst particles results in a greater number of catalyst particles that provide more evenly distributed catalyst sites throughout the heavy oil.

IV. UPGRADED EBULLATED BED REACTOR

[0114] Figure 4 schematically illustrates an example upgraded ebullated bed hydroprocessing system 400 that can be used in the disclosed methods and systems. Ebullated bed hydroprocessing system 400 includes an upgraded ebullated bed reactor 430 and a hot separator 404 (or other separator, such as a distillation tower). To create upgraded ebullated bed reactor 430, a catalyst precursor 402 is initially pre-blended with a hydrocarbon diluent 404 in one or more mixers 406 to form a catalyst precursor mixture 409. Catalyst precursor mixture 409 is added to feedstock 408 and blended with the feedstock in one or more mixers 410 to form conditioned feedstock 411. Conditioned feedstock is fed to a surge vessel 412 with pump around 414 to cause further mixing and dispersion of the catalyst precursor within the conditioned feedstock.

[0115] The conditioned feedstock from surge vessel 412 is pressurized by one or more pumps 416, passed through a pre-heater 418, and fed into ebullated bed reactor 430 together with pressurized hydrogen gas 420 through an inlet port 436 located at or near the bottom of ebullated bed reactor 430. Heavy oil material 426 in ebullated bed reactor 430 contains dispersed metal sulfide catalyst particles, schematically depicted as catalyst particles 424.

[0116] Heavy oil feedstock 408 may comprise any desired fossil fuel feedstock and/or fraction thereof including, but not limited to, one or more of heavy crude, oil sands bitumen, bottom of the barrel fractions from crude oil, atmospheric tower bottoms, vacuum tower bottoms, coal tar, liquefied coal, and other resid fractions. In some embodiments, heavy oil feedstock 408 can include a significant fraction of high boiling point hydrocarbons (*i.e.*, nominally at or above 343°C (650°F), more particularly nominally at or above about 524°C (975°F)) and/or asphaltenes. Asphaltenes are complex hydrocarbon molecules that include a relatively low ratio of hydrogen to carbon that is the result of a substantial number of condensed aromatic and naphthenic rings with paraffinic side chains (See Figure 1). Sheets consisting of the condensed aromatic and naphthenic rings are held together by heteroatoms such as sulfur or nitrogen and/or polymethylene bridges, thio-ether bonds, and vanadium and nickel complexes. The asphaltene fraction also contains a higher content of sulfur and nitrogen than does crude oil or the rest of the vacuum resid, and it also contains higher concentrations of carbon-forming compounds (*i.e.*, that form coke precursors and sediment).

[0117] Ebullated bed reactor 430 further includes an expanded catalyst zone 442 comprising a heterogeneous catalyst 444. A lower heterogeneous catalyst free zone 448 is located below expanded catalyst zone 442, and an upper heterogeneous catalyst free zone 450 is located above expanded catalyst zone 442. Dispersed metal sulfide catalyst particles 424 are dispersed throughout material 426 within ebullated bed reactor 430, including expanded catalyst zone 442, heterogeneous catalyst free zones 448, 450, 452 thereby being available to promote upgrading reactions within what constituted catalyst free zones in the ebullated bed reactor prior to being upgraded to include the dual catalyst system.

[0118] To promote hydrocracking rather than mere hydrotreating reactions, the hydroprocessing reactor(s) are preferably operated at a temperature in a range of about 750°F (399°C) to about 860°F (460°C), more preferably in a range of about 780°F (416°C) to about 830°F (443°C), are preferably operated at a pressure in a range of about 1000 psig (6.9 MPa) to about 3000 psig (20.7 MPa), more preferably in a range of about 1500 psig (10.3 MPa) to about 2500 psig (17.2 MPa), and are preferably operated at a space velocity (LHSV) in a range of about 0.05 hr⁻¹ to about 0.45 hr⁻¹, more preferably in a range of about 0.15 hr⁻¹ to about 0.35 hr⁻¹. The difference between hydrocracking and hydrotreating can also be expressed in terms of resid conversion (wherein hydrocracking results in the substantial conversion of higher boiling to lower boiling

hydrocarbons, while hydrotreating does not). The hydroprocessing systems disclosed herein can result in a resid conversion in a range of about 40% to about 90%, preferably in a range of about 55% to about 80%. The preferred conversion range typically depends on the type of feedstock because of differences in processing difficulty between different feedstocks. Typically, conversion will be at least about 5% higher, preferably at least about 10% higher, compared to operating an ebullated bed reactor prior to upgrading to utilize a dual catalyst system as disclosed herein.

[0119] Material 426 in ebullated bed reactor 430 is continuously recirculated from upper heterogeneous catalyst free zone 450 to lower heterogeneous catalyst free zone 448 by means of a recycling channel 452 connected to an ebullating pump 454. At the top of recycling channel 452 is a funnel-shaped recycle cup 456 through which material 426 is drawn from upper heterogeneous catalyst free zone 450. Recycled material 426 is blended with fresh conditioned feedstock 411 and hydrogen gas 420.

[0120] Fresh heterogeneous catalyst 444 is introduced into ebullated bed reactor 430 through a catalyst inlet tube 458, and spent heterogeneous catalyst 444 is withdrawn through a catalyst withdrawal tube 460. Whereas the catalyst withdrawal tube 460 is unable to differentiate between fully spent catalyst, partially spent but active catalyst, and fresh catalyst, the existence of dispersed metal sulfide catalyst particles 424 provides additional catalytic activity, within expanded catalyst zone 442, recycle channel 452, and lower and upper heterogeneous catalyst free zones 448, 450. The addition of hydrogen to hydrocarbons outside of heterogeneous catalyst 444 minimizes formation of sediment and coke precursors, which are often responsible for deactivating the heterogeneous catalyst.

[0121] Ebullated bed reactor 430 further includes an outlet port 438 at or near the top through which converted material 440 is withdrawn. Converted material 440 is introduced into hot separator or distillation tower 404. Hot separator or distillation tower 404 separates one or more volatile fractions 405, which is/are withdrawn from the top of hot separator 404, from a resid fraction 407, which is withdrawn from a bottom of hot separator or distillation tower 404. Resid fraction 407 contains residual metal sulfide catalyst particles, schematically depicted as catalyst particles 424. If desired, at least a portion of resid fraction 407 can be recycled back to ebullated bed reactor 430 in order to form part of the feed material and to supply additional metal sulfide catalyst particles. Alternatively, resid fraction 407 can be further processed using downstream

processing equipment, such as another ebullated bed reactor. In that case, separator 404 can be an interstage separator.

[0122] In some embodiments, operating the upgraded ebullated bed reactor at similar or higher severity and/or throughput while producing vacuum residue products of improved quality can result in a rate of equipment fouling that is similar to or less than when initially operating the ebullated bed reactor. In general, improving the quality of vacuum residue products can reduce equipment fouling by reducing one or more of viscosity, asphaltene content, carbon content, sediment content, nitrogen content, and sulfur content.

V. VACUUM RESIDUES OF IMPROVED QUALITY

[0123] As disclosed herein, upgrading an ebullated bed hydroprocessing system to utilize a dual catalyst system can substantially improve the quality of vacuum residues that remain after upgrading heavy oil and removing lighter and more valuable fractions. Vacuum residue products of improved quality are characterized by one or more of reduced viscosity, reduced specific gravity (increased API gravity), reduced asphaltene content, reduced carbon content, reduced sulfur content, and reduced sediment content.

[0124] In some embodiments, the vacuum residue product of improved quality can be characterized by a reduction in viscosity (*e.g.*, as measured by Brookfield Viscosity at 300°F) of at least 10%, 15%, 20%, 25%, 30%, 40%, 50%, 60%, or 70% compared to when initially operating the ebullated bed reactor.

[0125] In some embodiments, the vacuum residue product of improved quality can be characterized by a reduction in asphaltene content of at least 5%, 7.5%, 10%, 12.5%, 15%, 20%, 25%, or 30% compared to when initially operating the ebullated bed reactor.

[0126] In some embodiments, the vacuum residue product of improved quality can be characterized by a reduction in micro carbon residue content (*e.g.*, as measured by MCR content) of at least 2%, 4%, 6%, 8%, 10%, 12.5%, 15%, or 20% compared to when initially operating the ebullated bed reactor.

[0127] In some embodiments, the vacuum residue product of improved quality can be characterized by a reduction in sulfur content of at least 5%, 7.5%, 10%, 15%, 20%, 25%, 30%, or 35% compared to when initially operating the ebullated bed reactor.

[0128] In some embodiments, the vacuum residue product of improved quality can be characterized by a reduction in density, which can be expressed as an increase in °API Gravity of

at least 0.4, 0.6, 0.8, 1.0, 1.3, 1.6, 2.0, 2.5 or 3.0, compared to when initially operating the ebullated bed reactor.

[0129] In some embodiments, the vacuum residue product of improved quality can be characterized by a reduction in sediment content of at least 2%, 4%, 6%, 8%, 10%, 12.5%, 15%, or 20% compared to when initially operating the ebullated bed reactor.

[0130] In general, vacuum residue products can be used for (1) fuel oil, (2) solvent deasphalting, (3) coking, (4) power plant fuel, and/or (5) partial oxidation (*e.g.*, gasification to generate hydrogen). Because of restrictions on the amount of contaminants that are permitted in the vacuum residue products, improving their quality using the dual catalyst system hydroprocessing systems disclosed herein can reduce the amount of more expensive cutter stocks otherwise required to bring the vacuum residue within specification. It can also reduce the burden on the overall process where the cutter stock is otherwise needed elsewhere for efficient operation of the overall hydroprocessing system.

[0131] Results from ebullated bed units have shown that bottoms products (*i.e.*, vacuum tower bottoms, VTB, fuel oil) can be produced with improved quality through the use of a dual catalyst system while still maintaining at least the same, or even higher, production rate of converted products compared to the non-dual catalyst operation.

[0132] In addition, when an ebullated bed is upgraded to use a dual catalyst system and the production rate of converted products is raised substantially above initial conditions, the bottoms product can be maintained at least at equal quality, when it would otherwise be expected to have reduced quality without the use of the dual catalyst system.

[0133] In a given ebullated bed system, the rate of production of converted products can be limited by minimum requirements for the quality of the vacuum tower bottoms product. Other things being equal, as production rate is increased (typically by some combination of increased reactor temperature, throughput, and resid conversion) the quality of bottoms products is reduced, and will at some point fall below a requirement or specification which governs the sale or use of the bottoms product. When this occurs, the economics of the overall refinery operation is negatively impacted due to loss of value from sales of the bottoms product. As a result, a refinery will adjust the operation of their ebullated bed system in order to ensure that bottoms product of acceptable quality is produced. Use of the dual catalyst system can permit an operator to maintain their economic viability.

[0134] With the dual catalyst system, the bottoms product quality is improved compared to what would be expected under comparable conditions without the dual catalyst system. This affords ebullated bed operators added flexibility in unit operation. For example, the ebullated bed unit may be operated in a fashion that results in a net improvement in bottoms quality. This can provide an economic advantage in that it can allow the bottoms product to be sold for a higher price by meeting the specifications for a more value-added use of the material. Alternately, the ebullated bed unit may be pushed to higher levels of production rate of converted products, while still maintaining at least equal bottoms quality. This provides an economic advantage by increasing the sales of high-value converted products (naphtha, diesel, vacuum gas oil) without negatively impacting the marketability of the bottoms product.

[0135] Higher rates of production of converted products can be achieved by increasing “reactor severity”, which is the combination of reactor temperature, throughput, and resid conversion that defines the overall reactor performance. Increased reactor severity, and therefore increased production rate, can be achieved by different combinations of condition changes, such as (a) increased temperature/conversion at constant throughput, (b) increased throughput/temperature at constant conversion, and (c) increased throughput, temperature, and conversion.

[0136] Viscosity of vacuum tower bottoms products is often measured in units of cP (centipoise). The magnitude of the change in viscosity with dual catalyst usage depends on multiple factors, including the type of heavy oil feedstock and the ebullated bed operating conditions. Under conditions of equal production rate of converted products, the dual catalyst has been shown to reduce the viscosity of vacuum tower bottoms by:

- 40-50% for Ural vacuum resid feedstock;
- 30-50% for Arab Medium vacuum resid feedstock;
- 60-70% for Athabasca vacuum resid feedstock;
- 40-50% for Maya atmospheric resid feedstock.

[0137] The API Gravity of VTB products is measured in degrees (°) API gravity, which is related to the specific gravity of the material through the formula: $SG \text{ (at 60F)} = 141.5 / (\text{API Gravity} + 131.5)$. VTB products have high density and low API gravity, with the gravity near zero, or even below zero. Under conditions of equal production rate of converted products, the dual catalyst system has been shown to increase the API gravity of vacuum tower bottoms by:

- ~1 °API for Arab Medium vacuum resid feedstock;

- up to 10 °API for Athabasca vacuum resid feedstock;
- ~0.2 °API for Maya atmospheric resid feedstock.

[0138] Asphaltene content can be measured in weight percent content and defined as the difference between heptane insoluble content and toluene insolubles content. Asphaltenes defined in this fashion are commonly referred to as “C₇ asphaltenes”. An alternate definition is pentane insolubles minus toluene insolubles, commonly referred to as “C₅ asphaltenes”. In the following examples, the C₇ asphaltene definition is used.

[0139] Under conditions of equal production rate of converted products, the dual catalyst system has been shown to reduce the asphaltene content of VTB product by:

- 15-20% (relative) for Ural vacuum resid feedstock
- at least 30-40% (relative) for Arab Medium vacuum resid feedstock
- ~50% (relative) for Athabasca vacuum resid feedstock.

[0140] Carbon residue content is measured in weight percent content by the microcarbon residue (MCR) or Conradson carbon residue (CCR) method. Under conditions of equal production rate of converted products, the dual catalyst system has been shown to reduce the MCR content of VTB product by:

- 10-15% (relative) for Ural vacuum resid feedstock;
- ~30% (relative) for Athabasca vacuum resid feedstock.

[0141] Sulfur content is measured in weight percent content. Under conditions of equal production rate of converted products, the dual catalyst system has been shown to reduce the sulfur content of VTB product by:

- ~30% (relative) for Ural vacuum resid feedstock;
- 25-30% (relative) for Arab Medium vacuum resid feedstock;
- Up to 40% (relative) for Athabasca vacuum resid feedstock.

VI. EXPERIMENTAL STUDIES AND RESULTS

[0142] The following test studies demonstrate the effects and advantages of upgrading an ebullated bed reactor to use a dual catalyst system comprised of a heterogeneous catalyst and dispersed metal sulfide catalyst particles when hydroprocessing heavy oil. In particular, the test studies demonstrate the improvements in vacuum residue product quality that can be achieved by use of the present invention. The pilot plant used for this test was designed according to Figure 5.

As schematically illustrated in Figure 5, a pilot plant 500 with two ebullated bed reactors 512, 512' connected in series was used to determine the difference between using a heterogeneous catalyst by itself when processing heavy oil feedstocks and a dual catalyst system comprised of a heterogeneous catalyst in combination with dispersed metal sulfide catalyst particles (*i.e.*, dispersed molybdenum disulfide catalyst particles).

[0143] For the following test studies, a heavy vacuum gas oil was used as the hydrocarbon diluent. The precursor mixture was prepared by mixing an amount of catalyst precursor with an amount of hydrocarbon diluent to form a catalyst precursor mixture and then mixing an amount of the catalyst precursor mixture with an amount of heavy oil feedstock to achieve the target loading of dispersed catalyst in the conditioned feedstock. As a specific illustration, for one test study with a target loading of 30 ppm dispersed metal sulfide catalyst in the conditioned feedstock (where the loading is expressed based on metal concentration), the catalyst precursor mixture was prepared with a 3000 ppm concentration of metal.

[0144] The feedstocks and operating conditions for the actual tests are more particularly identified below. The heterogeneous catalyst was a commercially available catalyst commonly used in ebullated reactors. Note that for comparative test studies for which no dispersed metal sulfide catalyst was used, the hydrocarbon diluent (heavy vacuum gas oil) was added to the heavy oil feedstock in the same proportion as when using a diluted precursor mixture. This ensured that the background composition was the same between tests using the dual catalyst system and those using only the heterogeneous (ebullated bed) catalyst, thereby allowing test results to be compared directly.

[0145] Pilot plant 500 more particularly included a high shear mixing vessel 502 for blending a precursor mixture comprised of a hydrocarbon diluent and catalyst precursor (*e.g.*, molybdenum 2-ethylhexanoate) with a heavy oil feedstock (collectively depicted as 501) to form a conditioned feedstock. Proper blending can be achieved by first pre-blending the catalyst precursor with a hydrocarbon diluent to form a precursor mixture.

[0146] The conditioned feedstock is recirculated out and back into the mixing vessel 502 by a pump 504, similar to a surge vessel and pump-around. A high precision positive displacement pump 506 draws the conditioned feedstock from the recirculation loop and pressurizes it to the reactor pressure. Hydrogen gas 508 is fed into the pressurized feedstock and the resulting mixture is passed through a pre-heater 510 prior to being introduced into first ebullated bed

reactor 512. The pre-heater 510 can cause at least a portion of the catalyst precursor within the conditioned feedstock to decompose and form active catalyst particles *in situ* within the feedstock.

[0147] Each ebullated bed reactor 512, 512' can have a nominal interior volume of about 3000 ml and include a mesh wire guard 514 to keep the heterogeneous catalyst within the reactor. Each reactor is also equipped with a recycle line and recycle pump 513, which provides the required flow velocity in the reactor to expand the heterogeneous catalyst bed. The combined volume of both reactors and their respective recycle lines, all of which are maintained at the specified reactor temperature, can be considered to be the thermal reaction volume of the system and can be used as the basis for calculation of the Liquid Hourly Space Velocity (LHSV). For these examples, "LHSV" is defined as the volume of vacuum residue feedstock fed to the reactor per hour divided by the thermal reaction volume.

[0148] A settled height of catalyst in each reactor is schematically indicated by a lower dotted line 516, and the expanded catalyst bed during use is schematically indicated by an upper dotted line 518. A recirculating pump 513 is used to recirculate the material being processed from the top to the bottom of reactor 512 to maintain steady upward flow of material and expansion of the catalyst bed.

[0149] Upgraded material from first reactor 512 is transferred together with supplemental hydrogen 520 into second reactor 512' for further hydroprocessing. A second recirculating pump 513' is used to recirculate the material being processed from the top to the bottom of second reactor 512' to maintain steady upward flow of material and expansion of the catalyst bed.

[0150] The further upgraded material from second reactor 512' is introduced into a hot separator 522 to separate low-boiling hydrocarbon product vapors and gases 524 from a liquid fraction 526 comprised of unconverted heavy oil. The hydrocarbon product vapors and gases 524 are cooled and pass into a cold separator 528, where they are separated into gases 530 and converted hydrocarbon products, which are recovered as separator overheads 532. The liquid fraction 526 from hot separator 522 is recovered as separator bottoms 534, which can be used for analysis.

Examples 1-6

[0151] Examples 1-6 were conducted in the abovementioned pilot plant and tested the ability of an upgraded ebullated bed reactor that employed a dual catalyst system to produce vacuum residue product with improved quality compared to an ebullated bed system operated with only

the heterogeneous catalyst. For this set of examples, the heavy oil feedstock was a Ural vacuum residue (Ural VR) with a nominal cut point of 1000°F (538°C). As described above, a conditioned feedstock was prepared by mixing an amount of catalyst precursor mixture with an amount of heavy oil feedstock to a final conditioned feedstock that contained the required amount of dispersed catalyst. The exception to this were tests for which no dispersed catalyst was used, in which case heavy vacuum gas oil was substituted for the catalyst precursor mixture at the same proportion.

[0152] The conditioned feedstock was fed into the pilot plant system of Figure 5, which was operated using specific parameters. The parameters used for each of Examples 1 to 6 and the corresponding vacuum residue product quality results are set forth in Table 3.

Table 3

| Run Parameters | Example | | | | | |
|---|--------------|--------------|--------------|--------------|--------------|--------------|
| | 1 | 2 | 3 | 4 | 5 | 6 |
| Dispersed Catalyst Concentration (ppm Mo) | 0 | 0 | 30 | 30 | 50 | 50 |
| Reactor Temperature (°F/°C) | 789 (421) | 801 (427) | 789 (421) | 801 (427) | 789 (421) | 801 (427) |
| LHSV, vol. feed/vol. reactor/hr | 0.24 | 0.24 | 0.24 | 0.24 | 0.24 | 0.24 |
| Resid Conversion, based on 1000°F+, % | 60% | 68% | 58% | 67% | 56% | 66% |
| Properties of 1000°F+ Vacuum Residue Product Cut | | | | | | |
| Brookfield viscosity, cp at 300°F | 123 | 146 | 66 | 93 | 27 | 34 |
| Sulfur Content, wt% | 1.47 | 1.69 | 1.28 | 1.48 | 1.05 | 1.12 |
| C ₇ Asphaltene Content, wt% | 12.9 | 15.8 | 10.5 | 13.2 | 10.0 | 12.3 |
| Carbon Residue Content, wt% (by MCR) | 27.3 | 31.8 | 23.5 | 28.0 | 23.2 | 26.3 |

[0153] Examples 1 and 2 utilized a heterogeneous catalyst to simulate an ebullated bed reactor prior to being upgraded to employ a dual catalyst system according to the invention. Examples 3-6 utilized a dual catalyst system comprised of the same heterogeneous catalyst of Examples 1 and 2 and also dispersed molybdenum sulfide catalyst particles. The concentration of dispersed molybdenum sulfide catalyst particles in the feedstock was measured as concentration in parts per million (ppm) by weight of molybdenum metal (Mo) provided by the dispersed catalyst. The feedstock of Examples 1 and 2 included no dispersed catalyst (0 ppm Mo), the feedstock of Examples 3 and 4 included dispersed catalyst at a concentration of 30 ppm Mo, and the

feedstock of Examples 5 and 6 included dispersed catalyst at a higher concentration of 50 ppm Mo.

[0154] For each of Examples 1-6, the pilot unit operation was maintained for a period of 5 days. Steady state operating data and product samples were collected during the final 3 days of each example test. To determine the quality of the vacuum residue product, samples of separator bottoms product were collected during the steady-state portion of the test and subjected to laboratory distillation using the ASTM D-1160 method to obtain a sample of vacuum residue product. For Examples 1-6, the vacuum residue product was based on a nominal cut point of 1000°F (538°C).

[0155] Example 1 was the baseline test in which Ural VR was hydroprocessed at a temperature of 789°F (421°C) and a space velocity of 0.24 hr⁻¹, resulting in a resid conversion (based on 1000°F+, %) of 60%. In Example 2, the temperature was 801°F (427°C), resulting in a resid conversion of 68%. Examples 3 and 4 were operated at the same parameters as Examples 1 and 2, respectively, except that the dual catalyst system of the present invention was now used, with a dispersed catalyst concentration of 30 ppm Mo. Likewise, Examples 5 and 6 employed the same combination of parameters, but at a higher dispersed catalyst concentration of 50 ppm Mo.

[0156] The dual catalyst system of Examples 3-6 resulted in significant improvements in vacuum residue product quality relative to the baseline tests of Examples 1 and 2. This is illustrated graphically in Figure 6, which shows a chart of Brookfield viscosity (measured at 300°F) of the vacuum residue product for Examples 1-6. To aid in making comparisons, results are plotted as a function of resid conversion, allowing the results to be compared at equal conversion. Across the entire range of resid conversion tested in Examples 1-6, there is a significant improvement (reduction) in product viscosity when the dual catalyst system is used.

[0157] Figure 7 shows the results for sulfur content of the vacuum residue product. Again, sulfur content is reduced significantly by the use of the dual catalyst system.

[0158] Asphaltene content of the vacuum residue product is also reduced by use of the dual catalyst system, as shown in Figure 8. Asphaltene content is defined based on C₇ asphaltenes, which are calculated as the difference between the heptane insoluble content and the toluene insoluble content. Here, the response differs somewhat from the viscosity and sulfur content, in that most of the improvement is achieved through use of 30 ppm dispersed catalyst.

[0159] Similar behavior is observed for the carbon residue content, measured by the microcarbon residue (MCR) method. These results are shown in Figure 9, and show a significant reduction with the use of 30 ppm dispersed catalyst.

Examples 7-13

[0160] Examples 7-13 were conducted with the same equipment and methods of Examples 1-6, except that the heavy oil feedstock was a refinery feed mix based primarily on Arab Medium vacuum residue (Arab Medium VR), also with a nominal cut point of 1000°F (538°C). Methods for the preparation of conditioned heavy oil feedstock were the same as described for Examples 1-6.

[0161] The conditioned feedstock was fed into the pilot plant system of Figure 5, which was operated using specific parameters. The parameters used for each of Examples 7-13 and the corresponding vacuum residue product quality results are set forth in Table 4.

Table 4

| Run Parameters | Example | | | | | | |
|---|--------------|--------------|--------------|--------------|--------------|--------------|--------------|
| | 7 | 8 | 9 | 10 | 11 | 12 | 13 |
| Dispersed Catalyst Concentration (ppm Mo) | 0 | 0 | 30 | 30 | 50 | 50 | 50 |
| Reactor Temperature (°F/°C) | 815 (435) | 803 (428) | 815 (435) | 803 (428) | 815 (435) | 814 (434) | 802 (428) |
| LHSV, vol. feed/vol. reactor/hr | 0.24 | 0.24 | 0.24 | 0.24 | 0.24 | 0.24 | 0.24 |
| Resid Conversion, based on 1000°F+, % | 81% | 73% | 80% | 71% | 79% | 81% | 72% |
| Properties of 1000°F+ Vacuum Residue Product Cut | | | | | | | |
| API Gravity (°) | -4.1 | -0.2 | -1.4 | 0.7 | -1.6 | -2.7 | 0.6 |
| Brookfield viscosity, cp at 300°F | 572 | 297 | 199 | 177 | 203 | 201 | 127 |
| Sulfur Content, wt% | 3.13 | 3.25 | 2.52 | 2.87 | 2.46 | 2.35 | 2.47 |

[0162] Examples 7 and 8 utilized a heterogeneous catalyst to simulate an ebullated bed reactor prior to being upgraded to employ a dual catalyst system according to the invention. Examples 9-13 utilized a dual catalyst system comprised of the same heterogeneous catalyst of Examples 7 and 8 and also dispersed molybdenum sulfide catalyst particles. The concentration of dispersed molybdenum sulfide catalyst particles in the feedstock was measured as concentration in parts per million (ppm) by weight of molybdenum metal (Mo) provided by the dispersed catalyst. The feedstock of Examples 7 and 8 included no dispersed catalyst (0 ppm Mo), the feedstock of

Examples 9 and 10 included dispersed catalyst at a concentration of 30 ppm Mo, and the feedstock of Examples 11-13 included dispersed catalyst at a higher concentration of 50 ppm Mo.

[0163] Similar to Examples 1-6, the pilot unit operations of Examples 7-13 were maintained for a period of 5 days, with steady state operating data and product samples being collected during the final 3 days of each example test. To determine the quality of the vacuum residue product, samples of separator bottoms product were collected during the steady-state portion of the test and subjected to laboratory distillation using the ASTM D-1160 method to obtain a sample of vacuum residue product. For Examples 7-13, the vacuum residue product was based on a nominal cut point of 1000°F (538°C).

[0164] Examples 7 and 8 were baseline tests in which the feedstock based on Arab Medium VR was hydroprocessed at a temperatures of 815°F (435°C) and of 803°F (428°C), respectively, and a space velocity of about 0.25 hr⁻¹, resulting in resid conversion (based on 1000°F+, %) of 81% and 73%, respectively. Examples 9 and 10 were operated at the same temperature and space velocity and similar resid conversions as Examples 7 and 8, respectively, except that the dual catalyst system of the present invention was used, with a dispersed catalyst concentration of 30 ppm Mo. Examples 11 and 12 used the same parameters as Example 7, and Example 13 was analogous to Example 8, but at a higher dispersed catalyst concentration of 50 ppm Mo.

[0165] The dual catalyst system of Examples 9-13 resulted in significant improvements in vacuum residue product quality relative to the baseline tests of Examples 7 and 8 for Arab Medium-based feedstock. This is illustrated graphically in Figure 10, which shows the °API gravity of the 1000°F+ vacuum residue product cut. While there is relatively little difference between the API gravity results at the low end of the resid conversion range, there is a significant increase in API gravity (*i.e.*, reduction in density, or specific gravity) for the vacuum residue product at high resid conversion when the dual catalyst system is used (Examples 9, 11, and 12).

[0166] Figure 11 shows the results for sulfur content of the vacuum residue cut for Examples 7-13. Sulfur content was reduced through the use of the dual catalyst system, with the reduction being achieved across the entire range of resid conversion tested.

[0167] Figure 12 shows the results for the Brookfield viscosity (measured at 300°F) of the vacuum residue product cut. There was a significant reduction in viscosity through the use of the

dual catalyst system, with the improvement being especially notable at higher resid conversion. In this case, significant improvement was achieved at 30 ppm dispersed catalyst.

Examples 14-19

[0168] Examples 14-19 were conducted with the same equipment and methods of Examples 1-6, except that the heavy oil feedstock was an Athabasca vacuum residue (Athabasca VR), with a nominal cut point of 975°F (524°C). Methods for the preparation of conditioned heavy oil feedstock were the same as described for Examples 1-6.

[0169] The conditioned feedstock was fed into the pilot plant system of Figure 5, which was operated using specific parameters. The parameters used for each of Examples 14-19 and the corresponding vacuum residue product quality results are set forth in Table 5.

Table 5

| Run Parameters | Example | | | | | |
|---|--------------|--------------|--------------|--------------|--------------|--------------|
| | 14 | 15 | 16 | 17 | 18 | 19 |
| Dispersed Catalyst Concentration (ppm Mo) | 0 | 0 | 0 | 50 | 50 | 50 |
| Reactor Temperature (°F/°C) | 798 (426) | 814 (434) | 824 (440) | 799 (426) | 814 (434) | 824 (440) |
| LHSV, vol. feed/vol. reactor/hr | 0.28 | 0.28 | 0.28 | 0.28 | 0.28 | 0.28 |
| Resid Conversion, based on 1000°F+, % | 72% | 80% | 87% | 74% | 81% | 86% |
| Properties of 1000°F+ Vacuum Residue Product Cut | | | | | | |
| API Gravity (°) | 6.5 | -2.8 | -7.2 | 6.6 | 3.4 | 0.1 |
| Sulfur Content, wt% | 1.68 | 2.07 | 2.51 | 1.60 | 1.62 | 1.81 |
| Brookfield viscosity, cp at 300°F | n/a | n/a | 3020 | 250 | 693 | 910 |
| Heptane insolubles content, wt% | n/a | n/a | 29.5 | 8.1 | 12.0 | 16.2 |
| Carbon Residue Content, wt% (by MCR) | n/a | n/a | 42.7 | 22.1 | 24.2 | 32.2 |

[0170] Examples 14-16 utilized a heterogeneous catalyst to simulate an ebullated bed reactor prior to being upgraded to employ a dual catalyst system according to the invention. Examples 17-19 utilized a dual catalyst system comprised of the same heterogeneous catalyst of Examples 14-16 and dispersed molybdenum sulfide catalyst particles. The concentration of dispersed molybdenum sulfide catalyst particles in the feedstock was measured as concentration in parts per million (ppm) by weight of molybdenum metal (Mo) provided by the dispersed catalyst. The feedstock of Examples 14-16 included no dispersed catalyst (0 ppm Mo) and the feedstock of Examples 17-19 included dispersed catalyst at a higher concentration of 50 ppm Mo.

[0171] Examples 14 and 17 were operated for a period of 6 days, with steady-state data and samples being collected during the final 3 days of the test. The remaining tests were operated for shorter durations. Examples 15 and 18 were operated for about 3 days, with operating data and samples collected during the final 2 days. Examples 17 and 19 were only operated for about 2 days, with data and samples only collected during the last day.

[0172] As with previous examples, the quality of the vacuum residue products from each test was determined by collecting samples of separator bottoms product during the steady-state portion of the test and subjecting them to laboratory distillation using the ASTM D-1160 method to obtain a sample of vacuum residue product. For Examples 14-19, the vacuum residue product was based on a nominal cut point of 975°F (524°C).

[0173] Examples 14-16 were baseline tests in which the Athabasca VR feedstock was hydroprocessed at temperatures of 798°F (425.5°C), 814°F (434°C), and 824°F (440°C), respectively, and a space velocity of 0.28 hr⁻¹, resulting in resid conversions (based on 975°F+, %) of 72%, 80% and 87%, respectively. Examples 17-19 were operated at the same temperature and space velocity and similar resid conversion as Examples 14-16, respectively, except that the dual catalyst system of the present invention was used, with a dispersed catalyst concentration of 50 ppm Mo.

[0174] The dual catalyst system of Examples 17-19 resulted in significant improvements in vacuum residue product quality relative to the baseline tests of Examples 14-16 for the Athabasca VR feedstock.

[0175] Figure 13 shows the results for API gravity of the 975°F+ vacuum residue product cut. Product gravity is increased (i.e. product density, or specific gravity, decreased) significantly through the use of the dual catalyst system, with a greater degree of improvement at higher resid conversion.

[0176] Similarly, Figure 14 shows the results for sulfur content of the vacuum residue product. Again, there is a significant improvement (i.e., reduction in sulfur content) by the use of the dual catalyst system, with the magnitude of the improvement increasing with increasing resid conversion.

[0177] Figure 15 shows results for the Brookfield viscosity of the vacuum residue cut, measured at 266°F (130°C). Viscosity data are not available for Examples 14 and 15, so only Examples 16-

19 are represented in this figure. The data show a major improvement in product viscosity through the use of the dual catalyst system.

[0178] Figure 16 shows results for the heptane insoluble (HI) content of the vacuum residue cut. Heptane insoluble content is similar to the C₇ asphaltene content. As with the viscosity data, HI results are not available for Examples 14 and 15. The results of Examples 16-19 show a significant reduction in HI content through the use of the dual catalyst system.

[0179] Figure 17 shows the results for carbon residue content of the vacuum residue product cut, measured by the microcarbon residue (MCR) method. Again, data for Examples 14 and 15 are not available, but the results of Examples 16-19 show a significant reduction in MCR content with the use of the dual catalyst system.

Examples 20-21

[0180] Examples 20 and 21 provide a further comparison and illustration of the benefits associated with improving the quality of vacuum residue with respect to sulfur content and the amount of cutter stock required to bring a typical vacuum residue into conformance with fuel oil specifications. Example 20 is based on actual results when operating a conventional ebullated bed hydroprocessing system using a heterogeneous catalyst to produce a vacuum tower bottoms (VTB) product from a Urals vacuum resid (VR) feedstock. Example 21 is based on actual results when operating an upgraded ebullated bed hydroprocessing system using a dual catalyst system including a heterogeneous catalyst and dispersed metal sulfide catalyst particles to produce a vacuum tower bottoms (VTB) product of improved quality from the Urals VR feedstock. The comparative results are shown in Table 6.

Table 6

| Conditions and Results | Example | |
|---|----------------|-------|
| | 20 | 21 |
| Feedstock Type | Urals | Urals |
| Resid Conversion, % | 58 | 66 |
| VTB, t/h | 105 | 85 |
| VTB Sulfur, wt% | 1.65 | 1.10 |
| Cutter stock Sulfur, wt% | 0.1 | 0.1 |
| Cutter stock required for 1% sulfur fuel oil, t/h | 75 | 9 |

[0181] From Examples 20 and 21 it can be seen that using the dual catalyst system of the invention can reduce the amount of cutter stock required to bring the VTB in line with

prescriptive fuel oil sulfur standards. In this case, the reduction in cutter stock was 88%. Because cutter stocks are by definition higher quality fractions, they have a retail value greater than VTB. Reducing the amount of cutter stock required to bring fuel oil within specification can represent a substantial cost savings. It also reduces the burden on the overall process where the cutter stock is otherwise required for efficient operation of the overall hydroprocessing system.

[0182] Examples 20 and 21 highlight the significance/benefit of increased resid conversion between the two examples. Because Example 21 has both a higher resid conversion and a higher quality bottoms product, there is a double benefit for the amount of cutter stock needed. Part of the reduction in cutter stock comes from an overall reduction in the amount VTB product (due to higher resid conversion), and part comes from the higher quality of VTB that is produced. In both cases, the amount of cutter stock otherwise required to dilute the VTB product is reduced.

[0183] The present invention may be embodied in other specific forms without departing from its spirit or essential characteristics. The described embodiments are to be considered in all respects only as illustrative and not restrictive. The scope of the invention is, therefore, indicated by the appended claims rather than by the foregoing description. All changes which come within the meaning and range of equivalency of the claims are to be embraced within their scope.

CLAIMS

1. A method of upgrading an ebullated bed hydroprocessing system that includes one or more ebullated bed reactors to improve bottoms product quality, comprising:

operating an ebullated bed reactor using a heterogeneous catalyst to hydroprocess heavy oil at initial conditions, including at an initial reactor severity and initial rate of production of converted products, and initially separating the converted products by a distillation process into one or more volatile fractions and an initial bottoms product, the initial bottoms product having an initial quality, including an initial viscosity;

thereafter upgrading the ebullated bed reactor to operate using a dual catalyst system comprised of dispersed metal sulfide catalyst particles and heterogeneous catalyst; and

operating the upgraded ebullated bed reactor using the dual catalyst system to hydroprocess a feed containing heavy oil and more than 0% and less than 5% by weight of a hydrocarbon oil diluent with a nominal boiling range between 200°C and 550°C and at a reactor severity that maintains or increases the rate of production of converted products relative to the initial rate of production of converted products; and

separating the converted products from the upgraded ebullated bed reactor by the distillation process into one or more volatile fractions and an improved bottoms product of higher quality than the initial quality of the initial bottoms product when operating the ebullated bed reactor at the initial conditions,

wherein the improved bottoms product has a viscosity that is reduced by at least 10% relative to the initial viscosity of the initial bottoms product of initial quality.

2. The method of claim 1, wherein the heavy oil comprises at least one of heavy crude oil, oil sands bitumen, residuum from refinery processes, visbreaker bottoms, atmospheric tower bottoms having a nominal boiling point of at least 343°C (650°F), vacuum tower bottoms having a nominal boiling point of at least 524°C (975°F), resid from a hot separator, resid pitch, products from solvent deasphalting, or vacuum residue.

3. The method of claim 1 or 2, where the initial bottoms product and the improved bottoms product are vacuum tower bottoms products or a vacuum residue product, produced by vacuum distillation of the converted products.

4. The method of claim 1 or 2, where the initial bottoms product and the improved bottoms product are atmospheric tower bottoms products or an atmospheric residue product, produced by atmospheric distillation of the converted products.

5. The method of any one of claims 1 to 4, wherein the viscosity of the improved bottoms product produced by the upgraded ebullated bed reactor is reduced by least 25%, or at least 40%, relative to the initial viscosity of the initial bottoms product of initial quality.

6. The method of any one of claims 1 to 5, wherein the improved bottoms product produced by the upgraded ebullated bed reactor and separated from the one or more volatile fractions has an API gravity that is increased relative to an initial API gravity of the initial bottoms product of initial quality.

7. The method of claim 6, wherein the API gravity of the improved bottoms product produced by the upgraded ebullated bed reactor is increased by at least 0.1 degree API, or at least 0.5 degree API, or at least 1 API degree, relative to the initial API gravity of the initial bottoms product of initial quality.

8. The method of any one of claims 1 to 7, wherein the improved bottoms product produced by the upgraded ebullated bed reactor and separated from the one or more volatile fractions has an asphaltene content that is reduced relative to an initial asphaltene content of the initial bottoms product of initial quality.

9. The method of claim 8, wherein the asphaltene content of the improved bottoms product produced by the upgraded ebullated bed reactor is reduced by at least 10%, or at least 20%, or at least 30%, relative to the initial asphaltene content of the initial bottoms product of initial quality.

10. The method of any one of claims 1 to 9, wherein the improved bottoms product produced by the upgraded ebullated bed reactor and separated from the one or more volatile fractions has a carbon residue content that is reduced relative to an initial carbon residue content of the initial bottoms product of initial quality.

11. The method of claim 10, wherein the carbon residue content of the improved bottoms product produced by the upgraded ebullated bed reactor is reduced by at least 5%, or at least 10%, or at least 20%, relative to the initial carbon residue content of the initial bottoms product of initial quality.

12. The method of any one of claims 1 to 11, wherein the improved bottoms product produced by the upgraded ebullated bed reactor and separated from the one or more volatile fractions has a sulfur content that is reduced relative to an initial sulfur content of the initial bottoms product of initial quality.

13. The method of claim 12, wherein the sulfur content of the improved bottoms product produced by the upgraded ebullated bed reactor is reduced by at least 10%, or at least 20%, or at least 30%, relative to the initial sulfur content of the initial bottoms product of initial quality.

14. The method of any one of claims 1 to 13, wherein the improved bottoms product produced by the upgraded ebullated bed reactor and separated from the one or more volatile fractions has a sediment content that is reduced relative to an initial sediment content of the initial bottoms product of initial quality.

15. The method of claim 15, wherein the sediment content of the improved bottoms product produced by the upgraded ebullated bed reactor is reduced by at least 5%, or at least 10%, or at least 20%, relative to the initial sediment content of the initial bottoms product of initial quality.

16. The method of any one of claims 1 to 15, wherein the dispersed metal sulfide catalyst particles are less than 1 μm in size, or less than 500 nm in size, or less than 100 nm in size, or less than 25 nm in size, or less than 10 nm in size.

17. The method of claim 16, the dispersed metal sulfide catalyst particles being formed *in situ* within the heavy oil from a catalyst precursor.

18. The method of claim 17, further comprising mixing the catalyst precursor with a diluent hydrocarbon to form a diluted precursor mixture, blending the diluted precursor mixture

with the heavy oil to form conditioned heavy oil, and heating the conditioned heavy oil to decompose the catalyst precursor and form the dispersed metal sulfide catalyst particles *in situ*.

19. The method of any one of claims 1 to 18, wherein operating the upgraded ebullated bed includes operating at a same or higher severity than when initially operating the ebullated bed.

20. The method of any one of claims 1 to 19, wherein operating the upgraded ebullated bed at a same or higher severity than when initially operating the ebullated bed includes operating at a same or higher throughput than when initially operating the ebullated bed.

21. The method of any one of claims 1 to 20, wherein operating the upgraded ebullated bed at a same or higher severity than when initially operating the ebullated bed includes operating at a same or higher temperature than when initially operating the ebullated bed.

22. The method of any one of claims 1 to 21, wherein operating the upgraded ebullated bed at a same or higher severity than when initially operating the ebullated bed includes operating at a same or higher conversion than when initially operating the ebullated bed.

23. A method of upgrading an ebullated bed hydroprocessing system that includes one or more ebullated bed reactors to improve bottoms product quality, comprising:

operating an ebullated bed reactor using a heterogeneous catalyst to hydroprocess heavy oil at initial conditions, including at an initial reactor severity and initial rate of production of converted products, and initially separating the converted products by a distillation process into one or more volatile fractions and an initial bottoms product, the initial bottoms product having an initial quality, including an initial viscosity;

thereafter upgrading the ebullated bed reactor to operate using a dual catalyst system comprised of dispersed metal sulfide catalyst particles and heterogeneous catalyst; and

operating the upgraded ebullated bed reactor using the dual catalyst system to hydroprocess a feed consisting essentially of heavy oil and a hydrocarbon oil diluent selected from the group consisting of vacuum gas oil having a nominal boiling range of 360-524°C and gas oil having a nominal boiling range of 200-360°C and at a reactor

severity that maintains or increases the rate of production of converted products relative to the initial rate of production of converted products; and

separating the converted products from the upgraded ebullated bed reactor by the distillation process into one or more volatile fractions and an improved bottoms product of higher quality than the initial quality of the initial bottoms product when operating the ebullated bed reactor at the initial conditions,

wherein the improved bottoms product has higher quality characteristics, including a viscosity that is reduced by at least 15% relative to the initial viscosity of the initial bottoms product of initial quality and at least one additional higher quality characteristic selected from:

increased API gravity relative to an initial API gravity of the initial bottoms product;

reduced asphaltene content relative to an initial asphaltene content of the initial bottoms product;

reduced carbon residue content relative to an initial carbon residue content of the initial bottoms product;

reduced sulfur content relative to an initial sulfur content of the initial bottoms product; and

reduced sediment content relative to an initial sediment content of the initial bottoms product.

24. The method of claim 23, where the initial bottoms product and the improved bottoms product are vacuum tower bottoms products or a vacuum residue product, produced by vacuum distillation of the converted products.

25. The method of claim 23, where the initial bottoms product and the improved bottoms product are atmospheric tower bottoms products or an atmospheric residue product, produced by atmospheric distillation of the converted products.

26. The method of any one of claims 14 to 25, wherein the upgraded ebullated bed is operated at a higher rate of production of converted products including operating at higher temperature and/or conversion while maintaining similar throughput than when operating the ebullated bed reactor at the initial conditions.

27. The method of any one of claims 14 to 25, wherein the upgraded ebullated bed is operated at a higher rate of production of converted products including operating at higher throughput and/or temperature while maintaining similar conversion than when operating the ebullated bed reactor at the initial conditions.

28. The method of any one of claims 14 to 25, wherein the upgraded ebullated bed is operated at a higher rate of production of converted products including operating at higher temperature, throughput and conversion than when operating the ebullated bed reactor at the initial conditions.

29. The method of any one of claims 14 to 28, wherein the bottoms product produced by the upgraded ebullated bed has an asphaltene content that is no higher than an asphaltene content of the bottoms product of initial quality.

30. The method of any one of claims 14 to 29, wherein the bottoms product produced by the upgraded ebullated bed has a carbon residue content that is no higher than a carbon residue content of the bottoms product of initial quality.

31. The method of any one of claims 14 to 30, wherein the bottoms product produced by the upgraded ebullated bed has a sulfur content that is no higher than a sulfur content of the bottoms product of initial quality.

32. The method of any one of claims 14 to 31, wherein the bottoms product produced by the upgraded ebullated bed has an API gravity at least as high as an API gravity of the bottoms product of initial quality.

33. The method of any one of claims 14 to 32, wherein the bottoms product produced by the upgraded ebullated bed has a sediment content no higher than a sediment content of the bottoms product of initial quality.

1/23

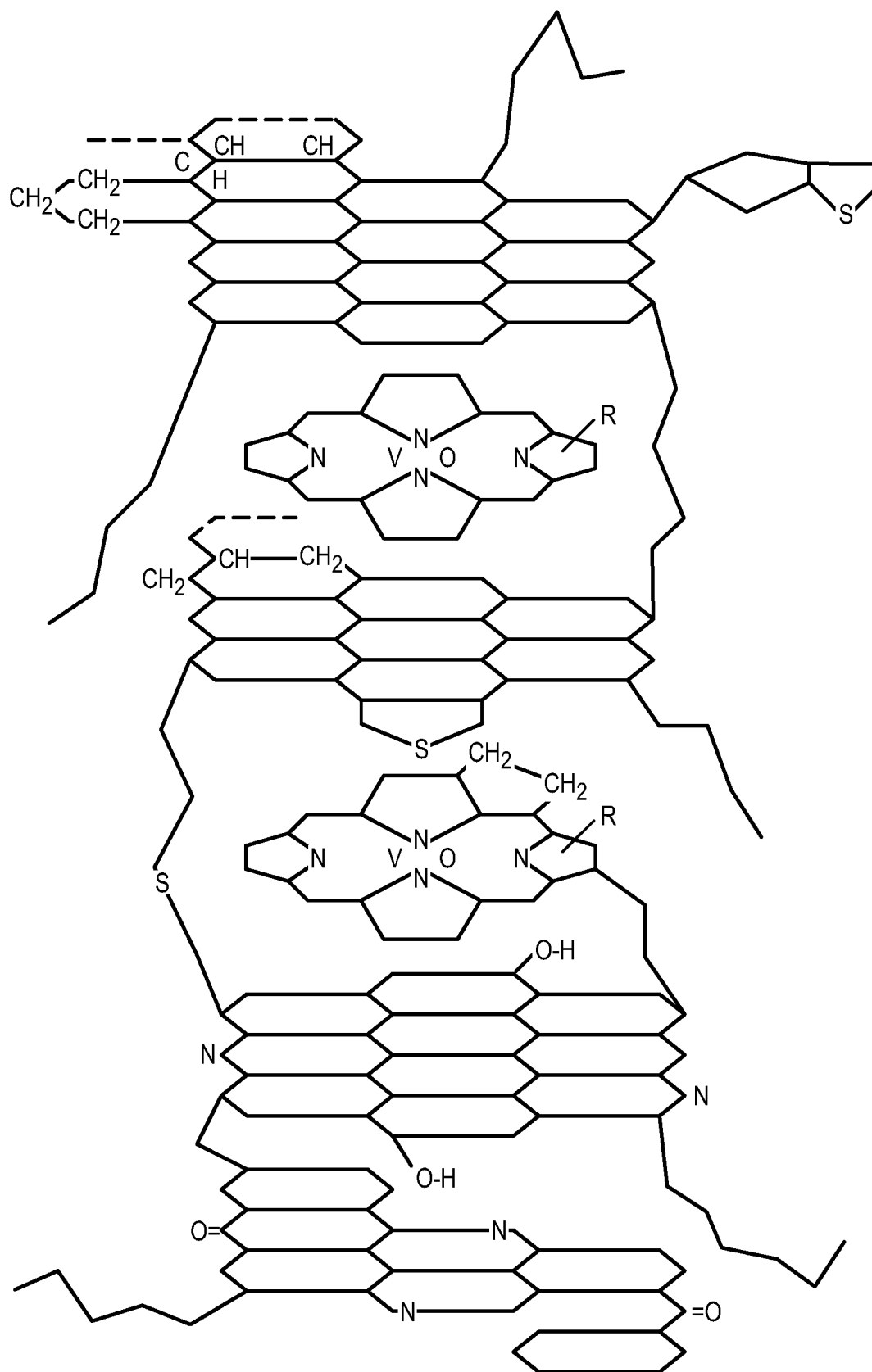
**Fig. 1**

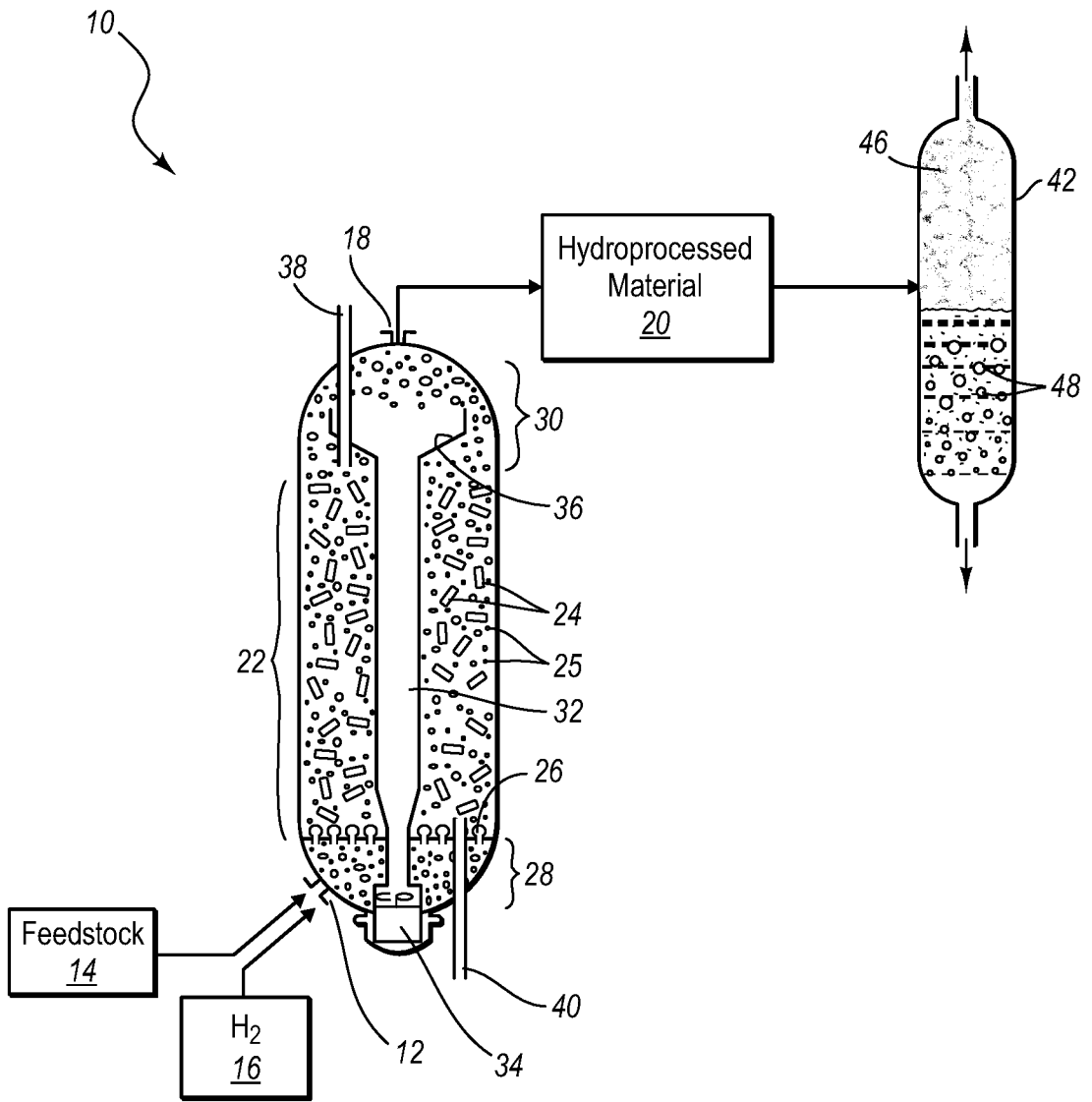

Fig. 2A

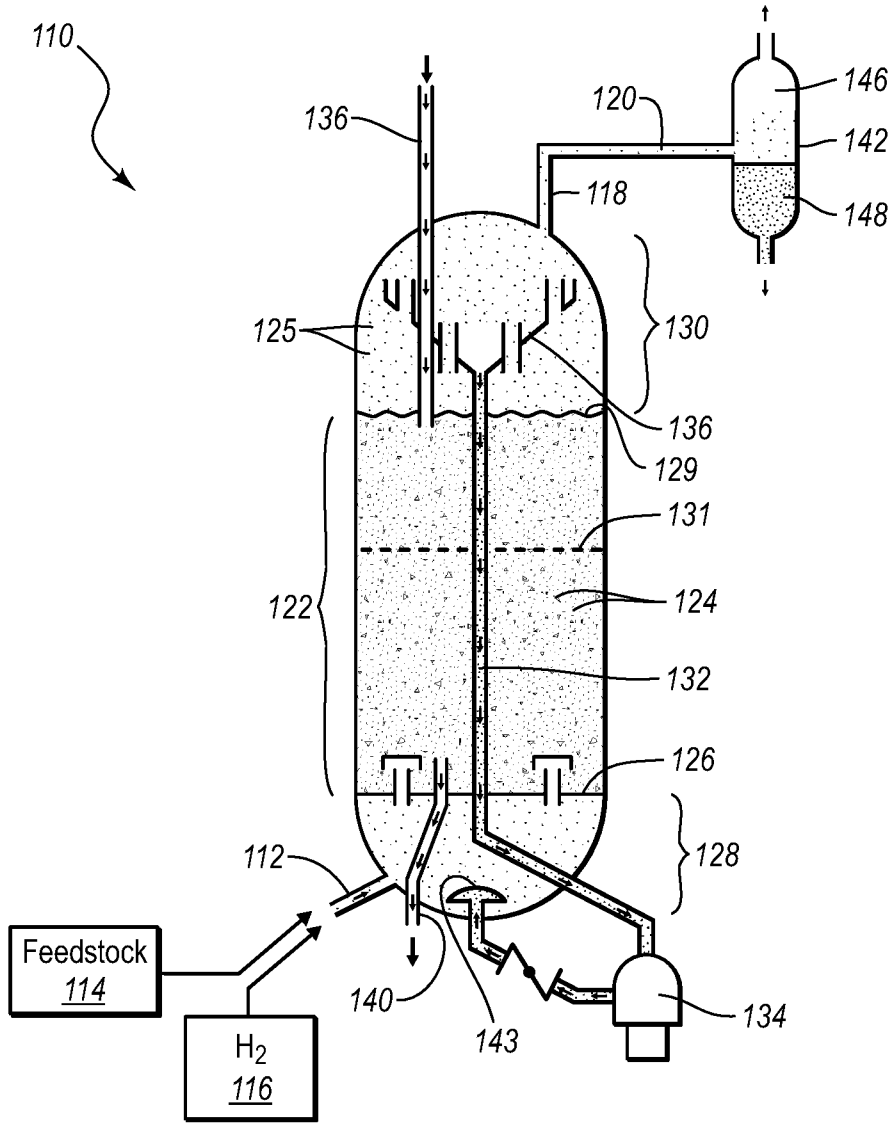

Fig. 2B

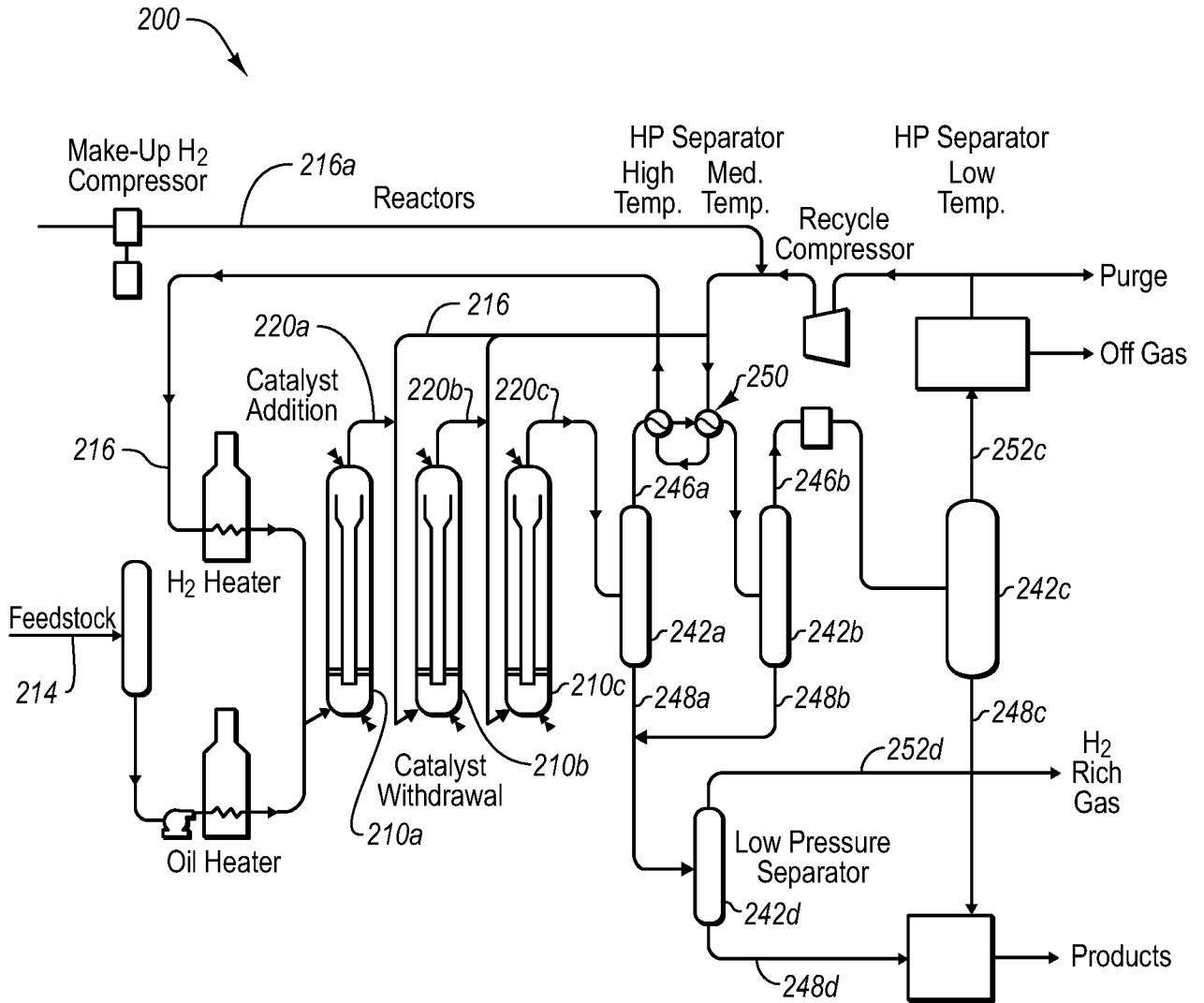

Fig. 2C

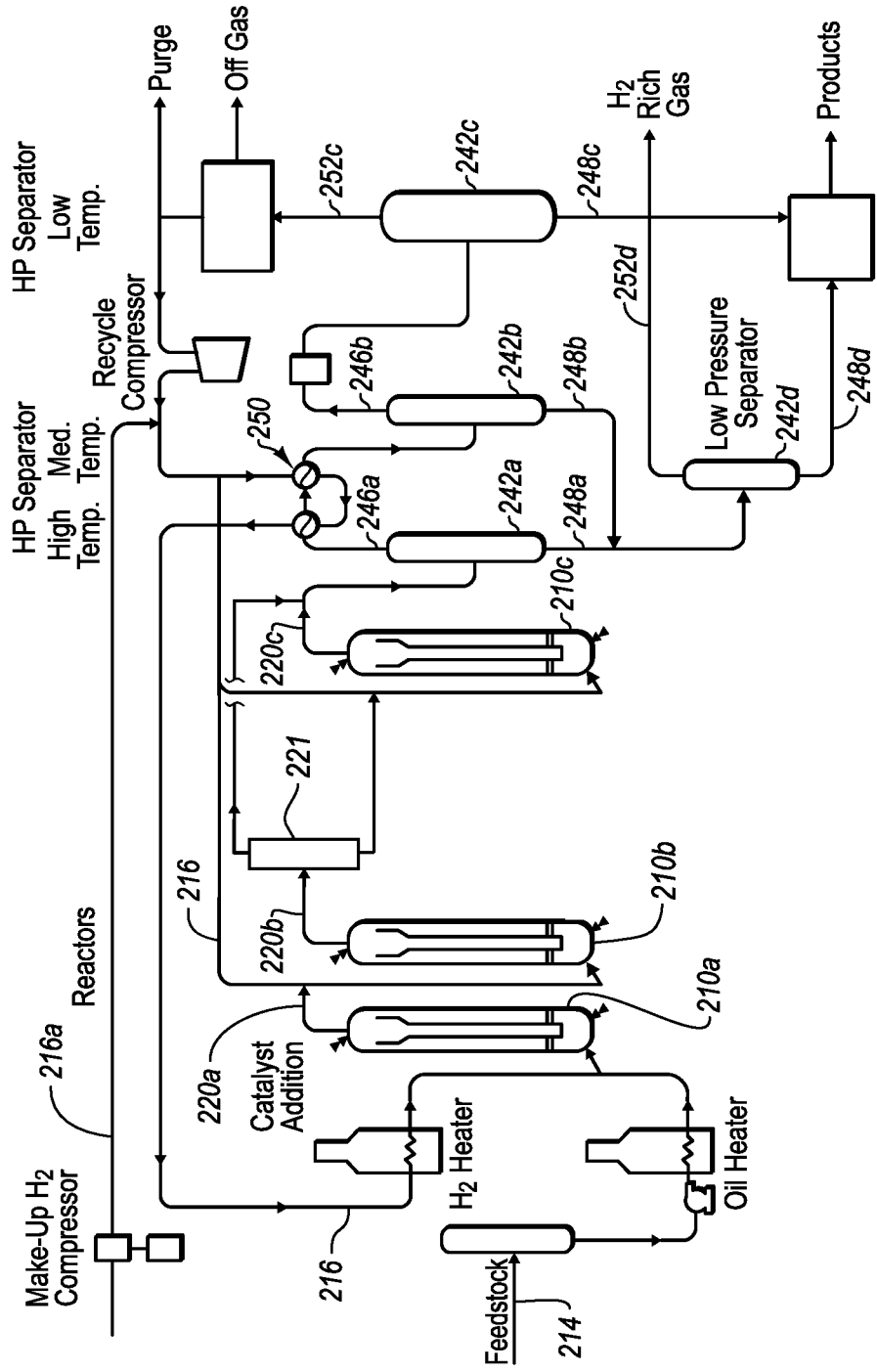
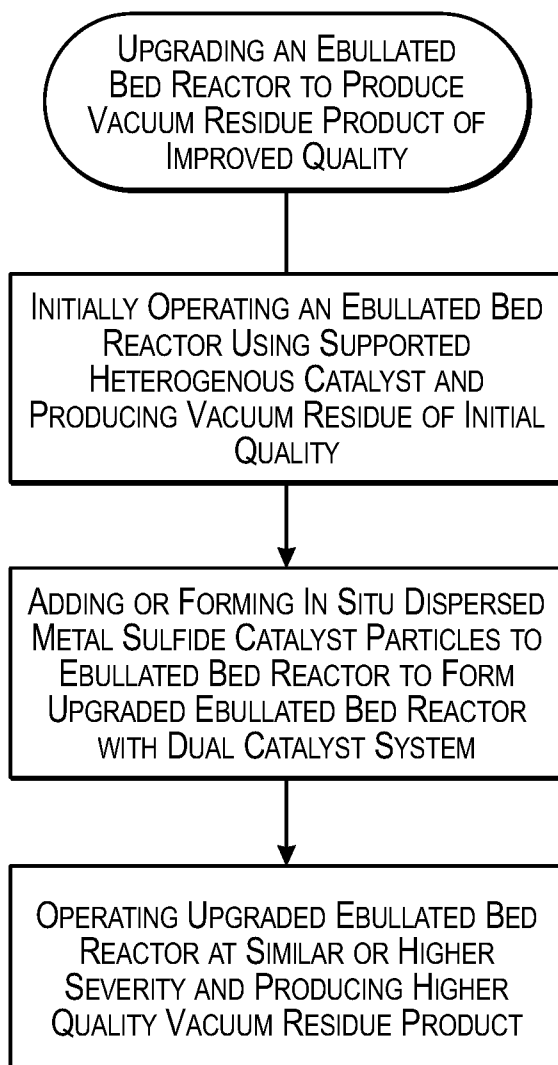
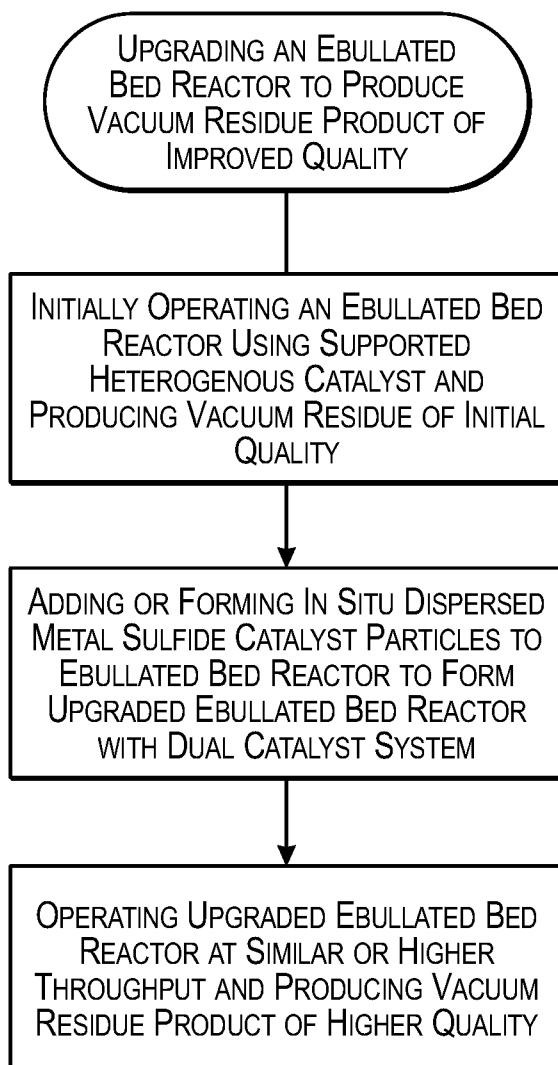

Fig. 2D

6/23

**Fig. 3A**

7/23

**Fig. 3B**

8/23

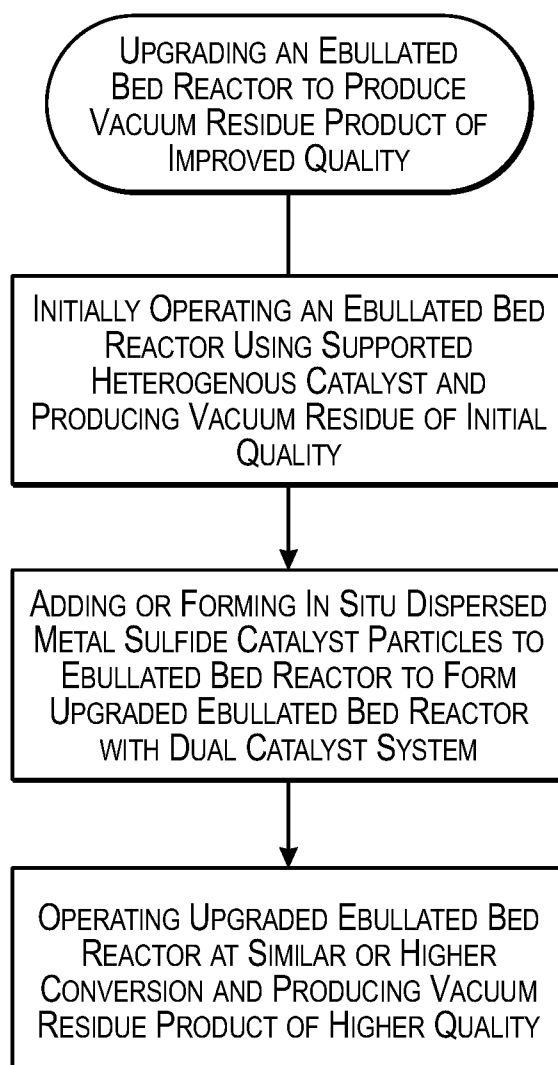
**Fig. 3C**

9/23

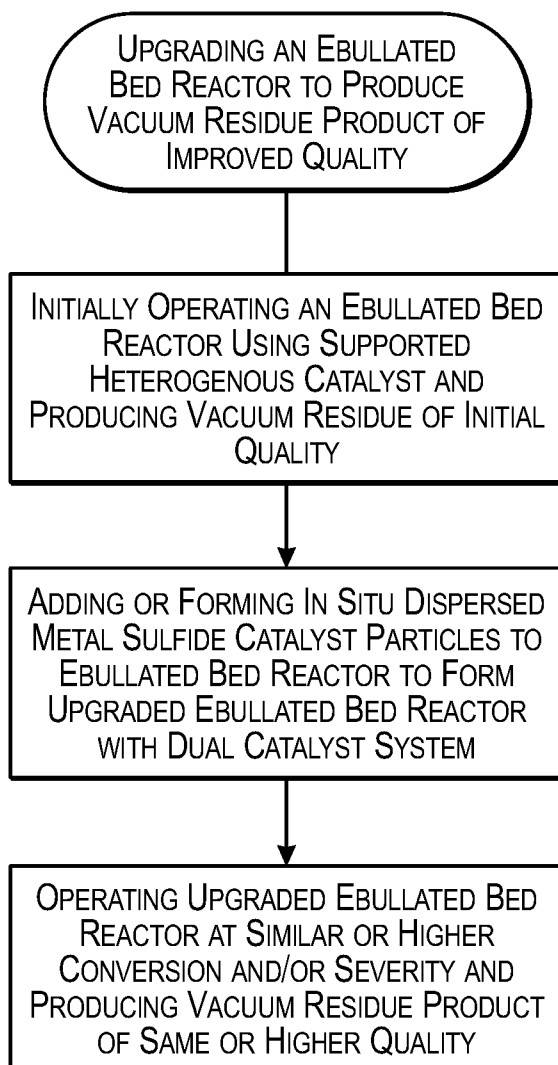
**Fig. 3D**

10/23

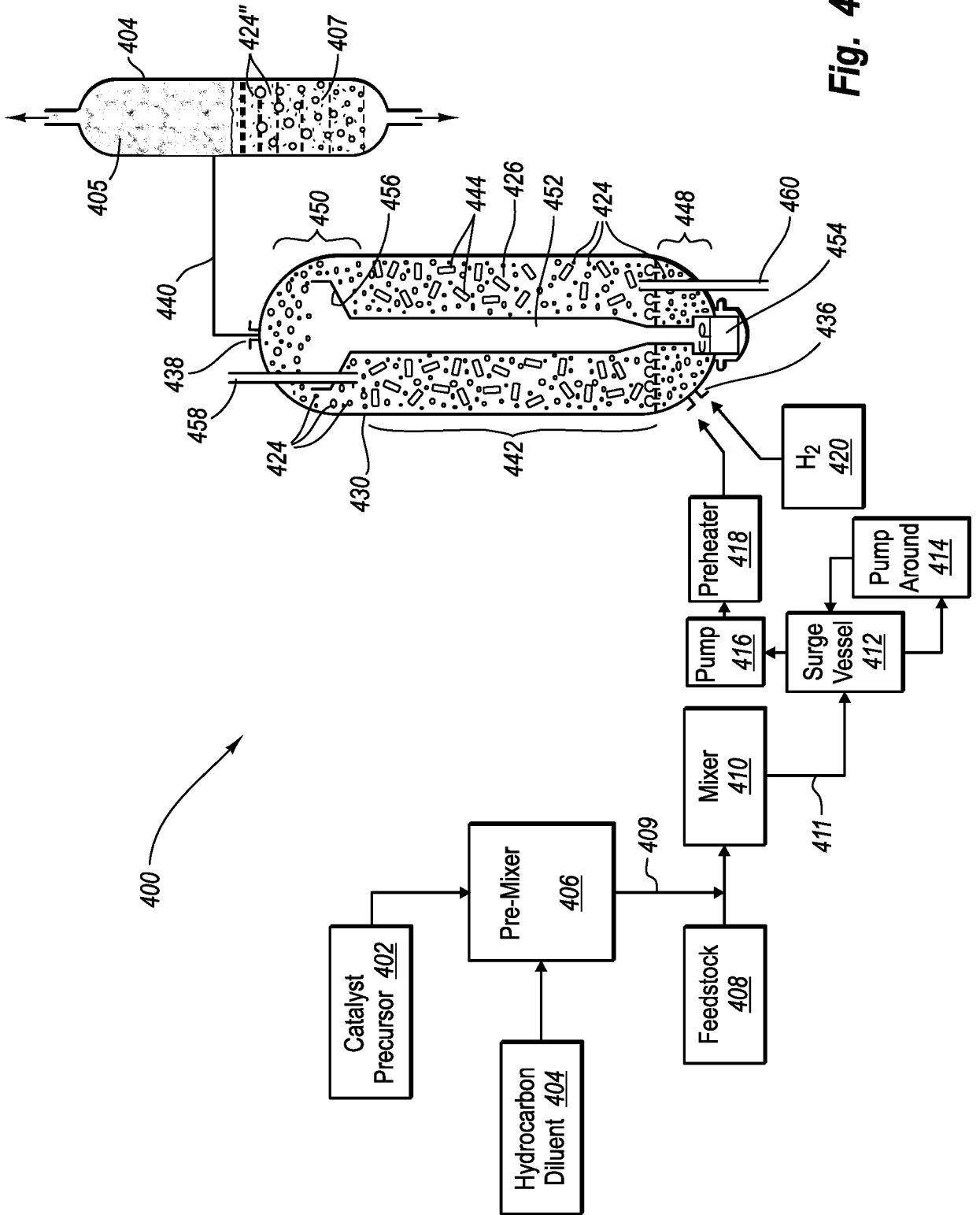

Fig. 4

11/23

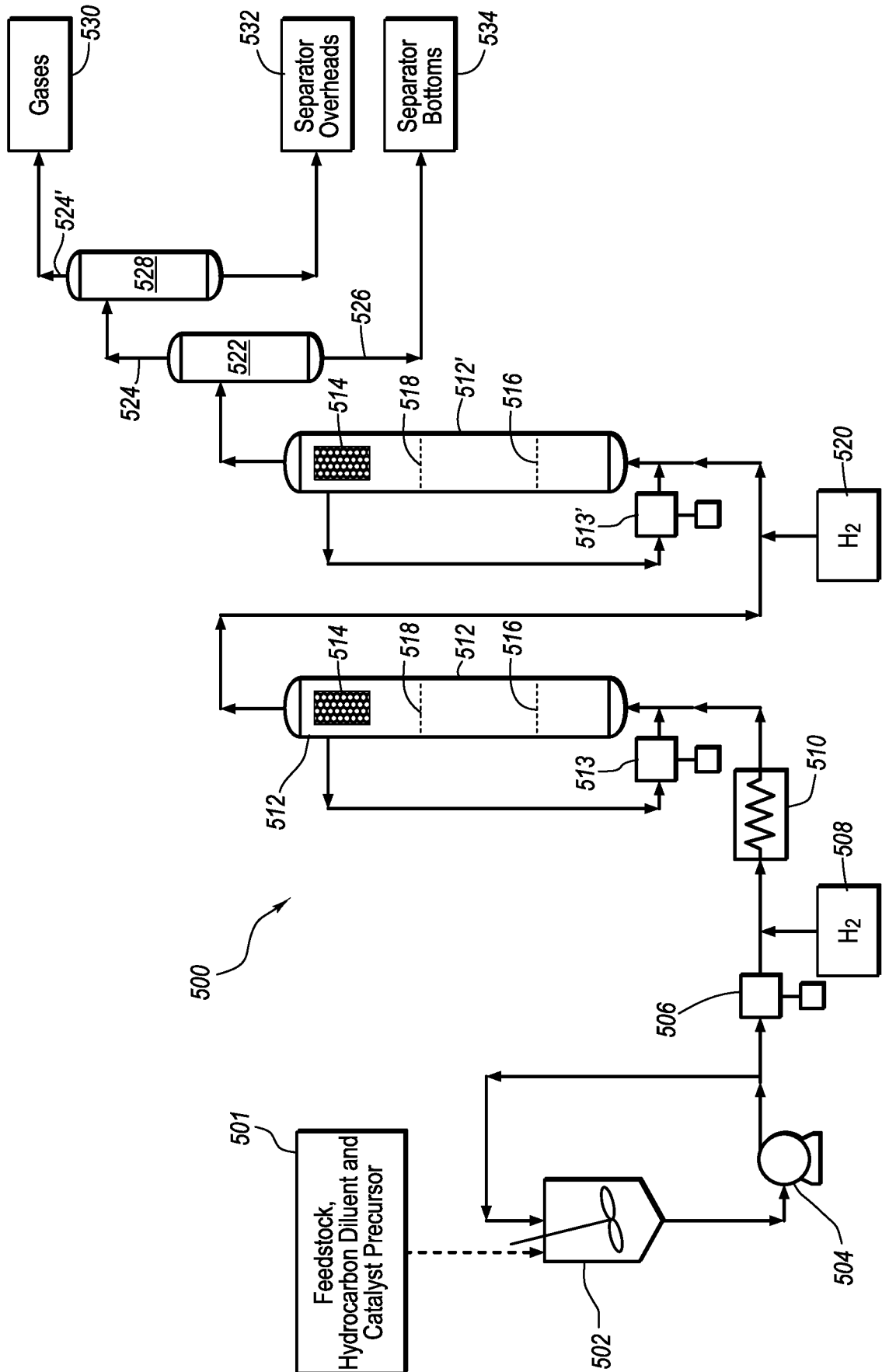

Fig. 5

12/23

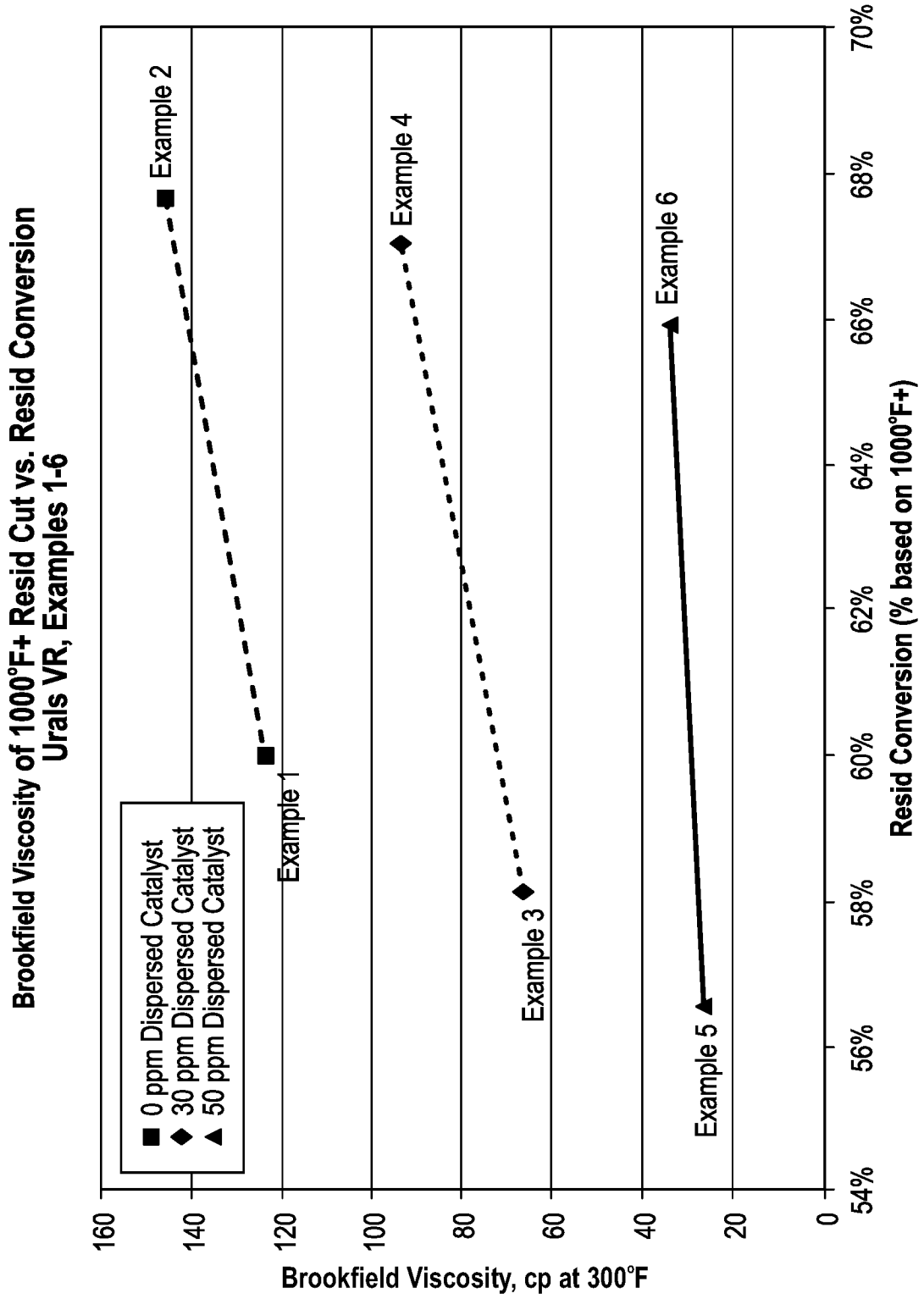

Fig. 6

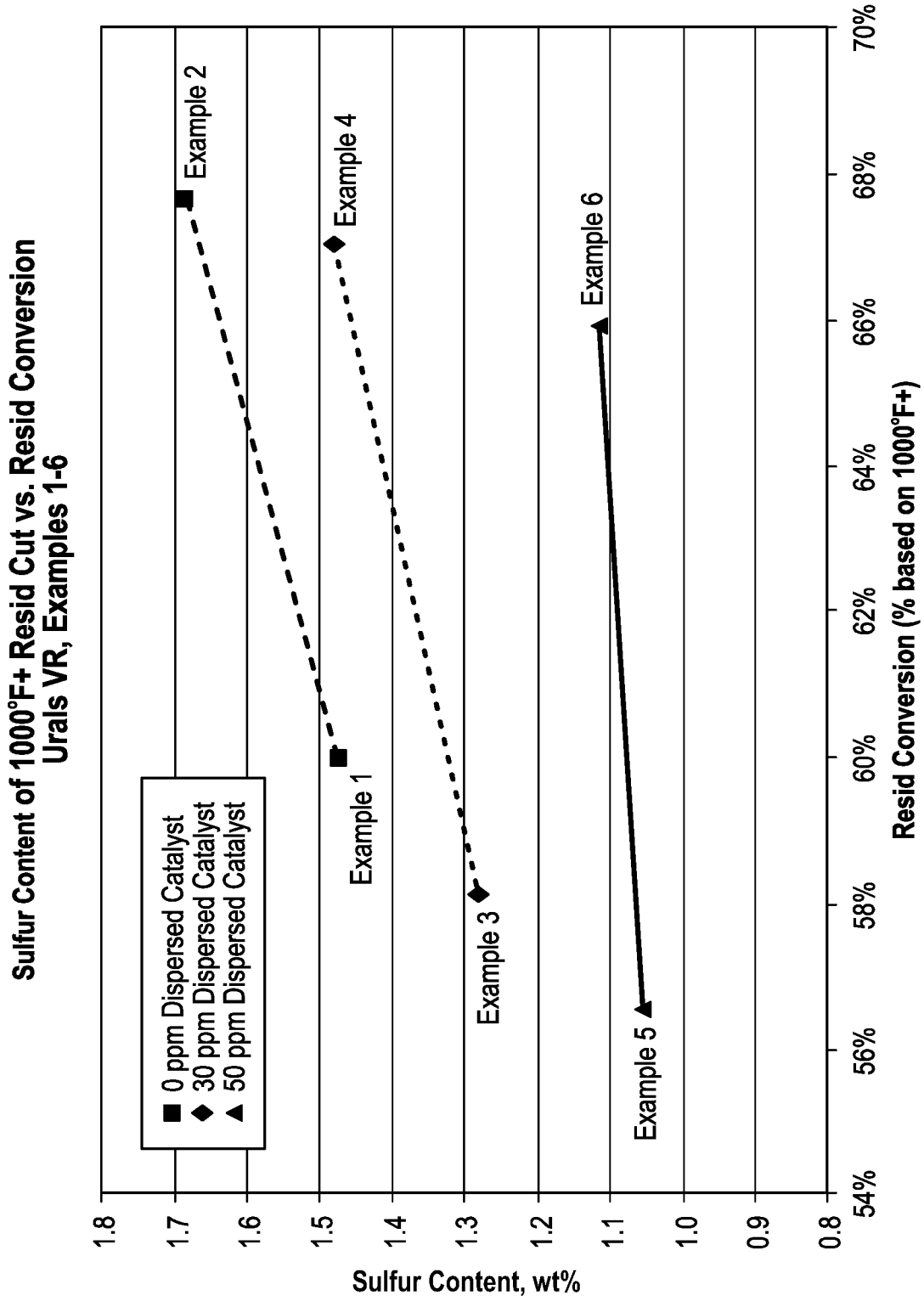

Fig. 7

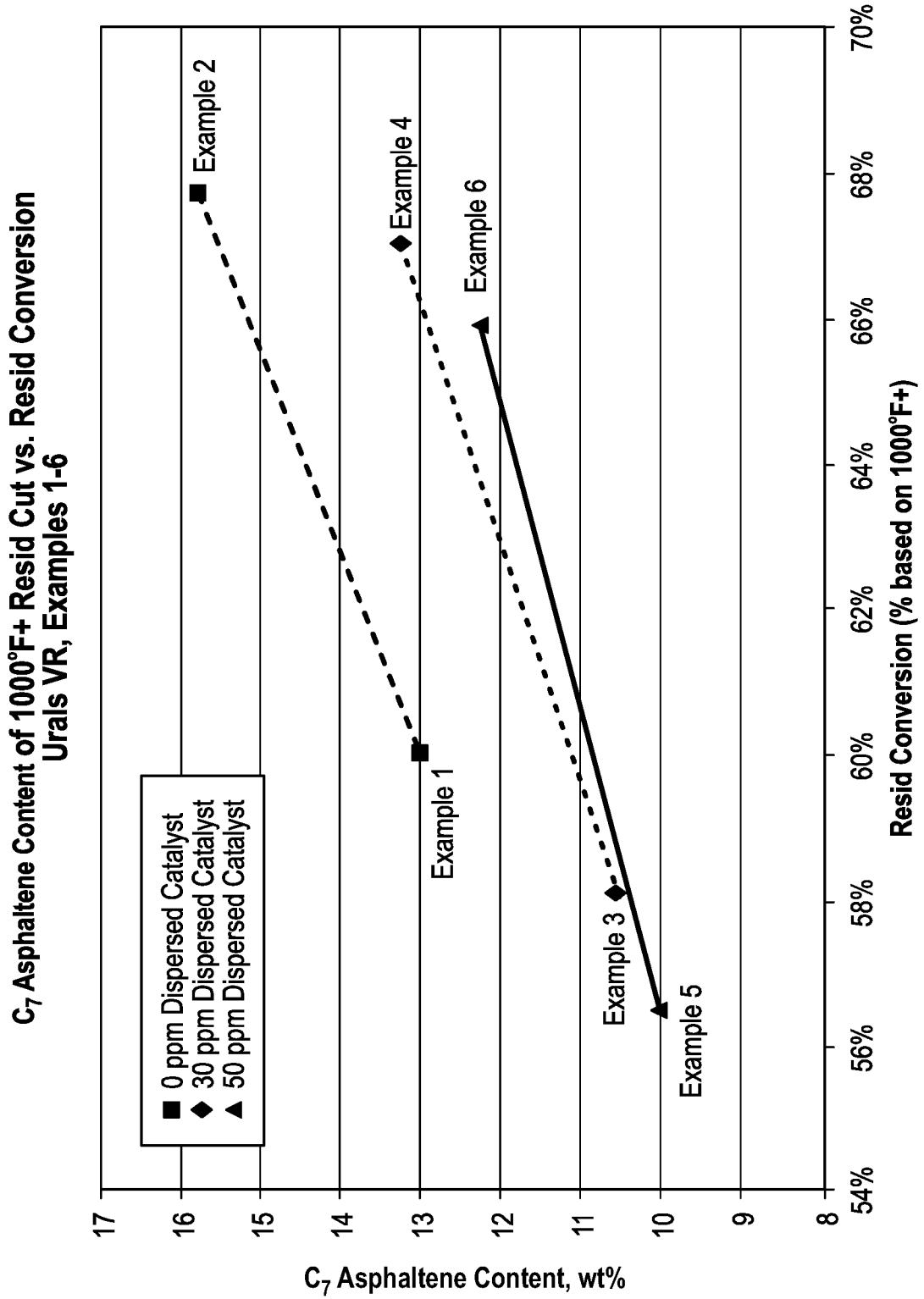

Fig. 8

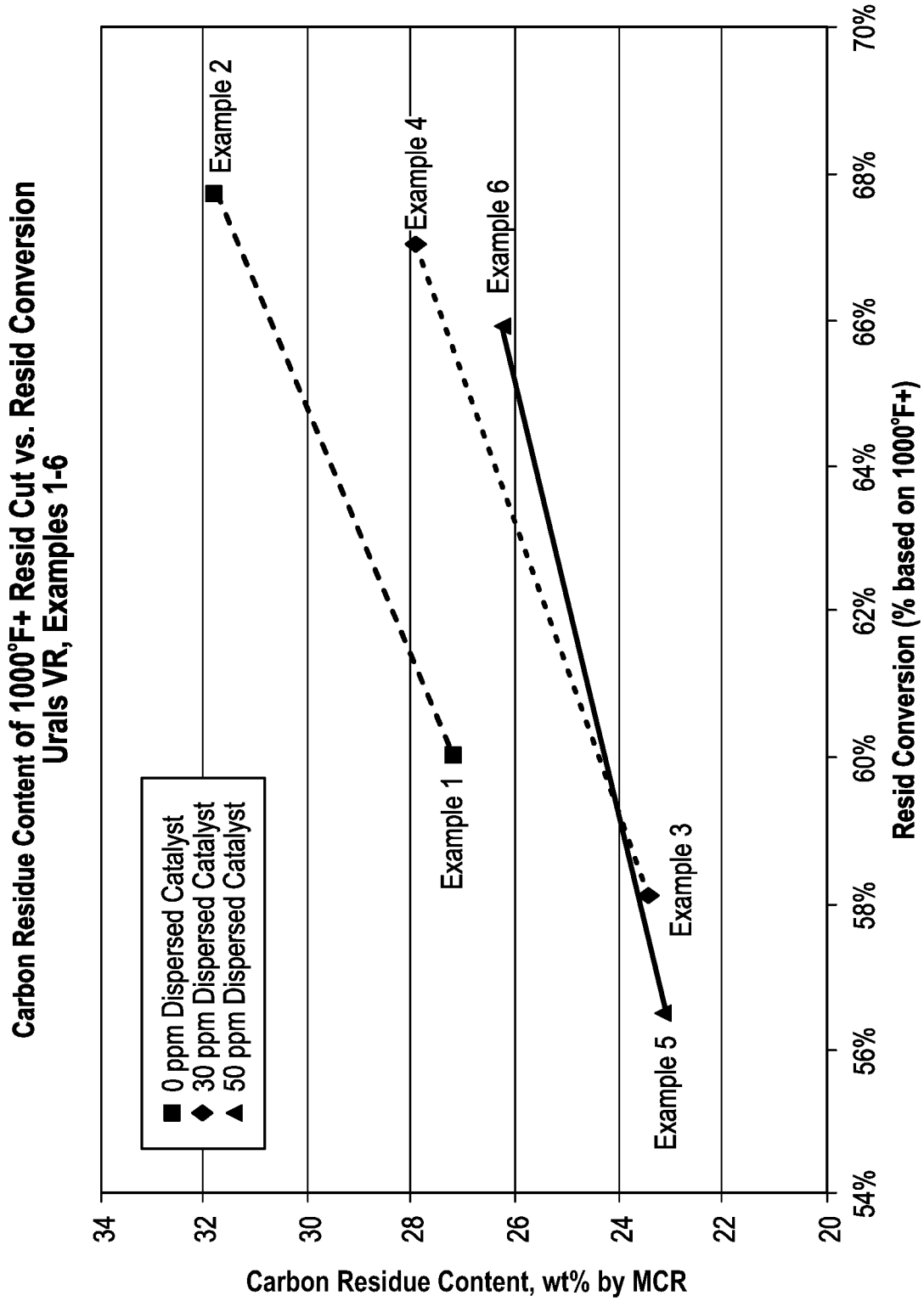

Fig. 9

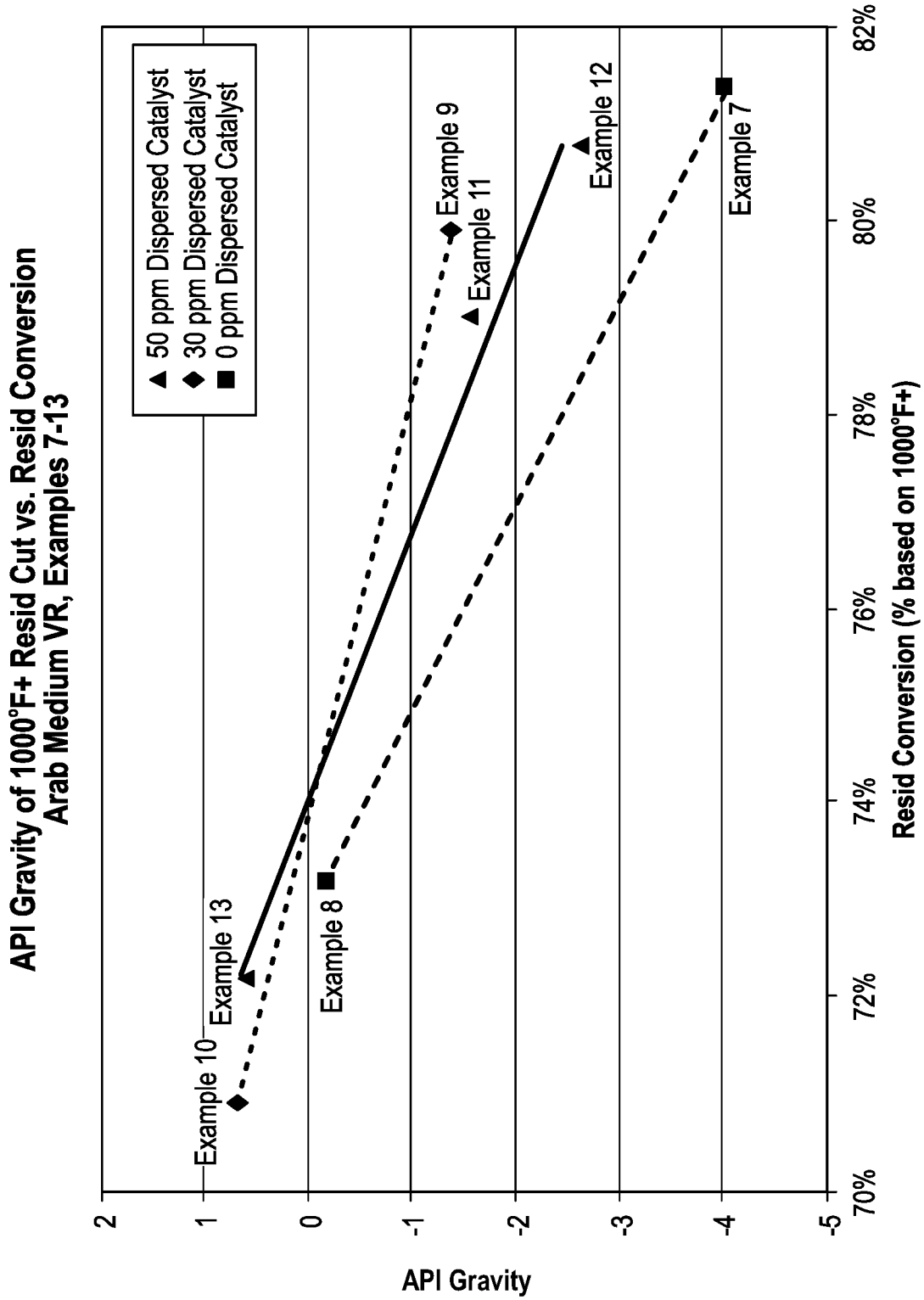

Fig. 10

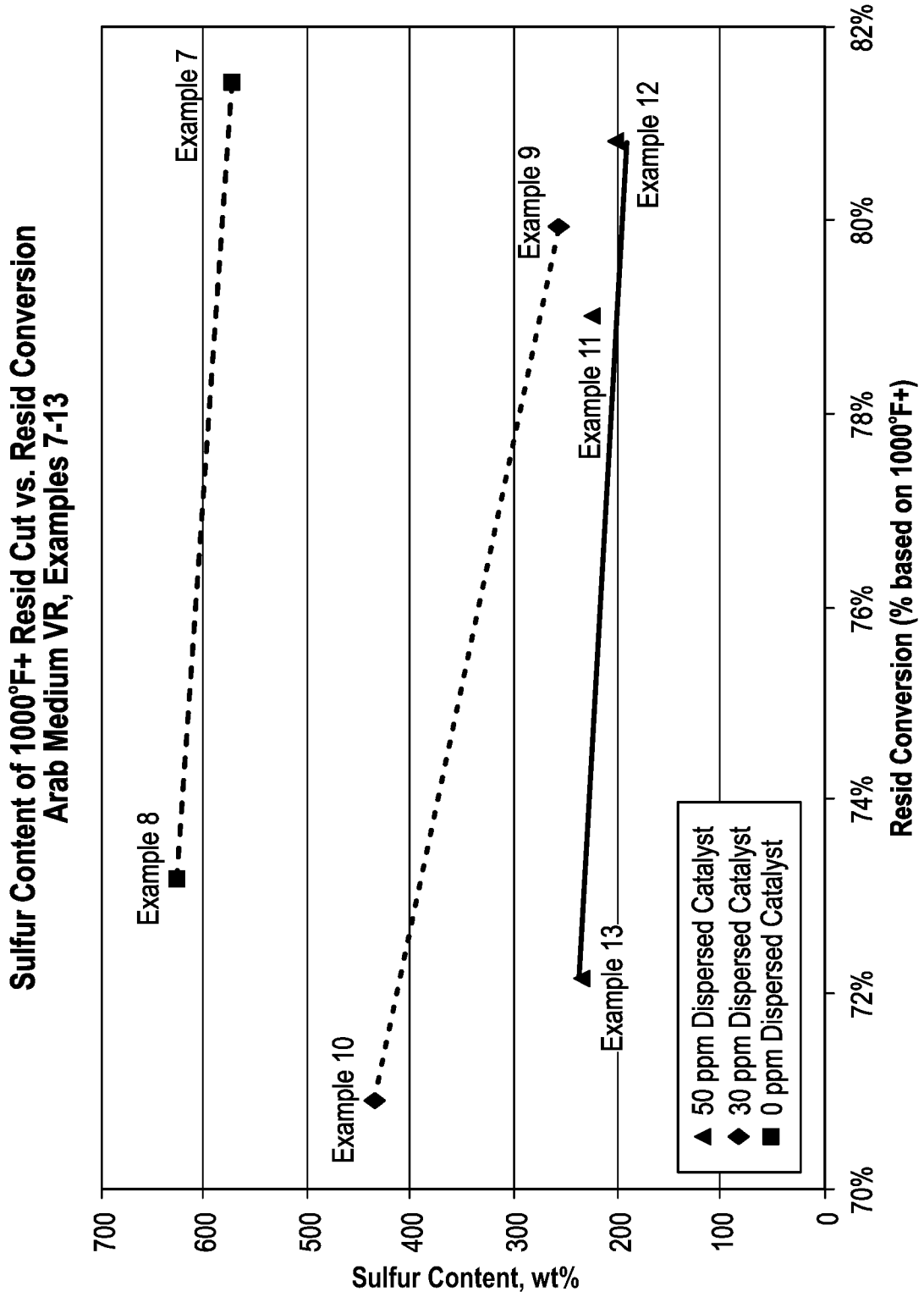

Fig. 11

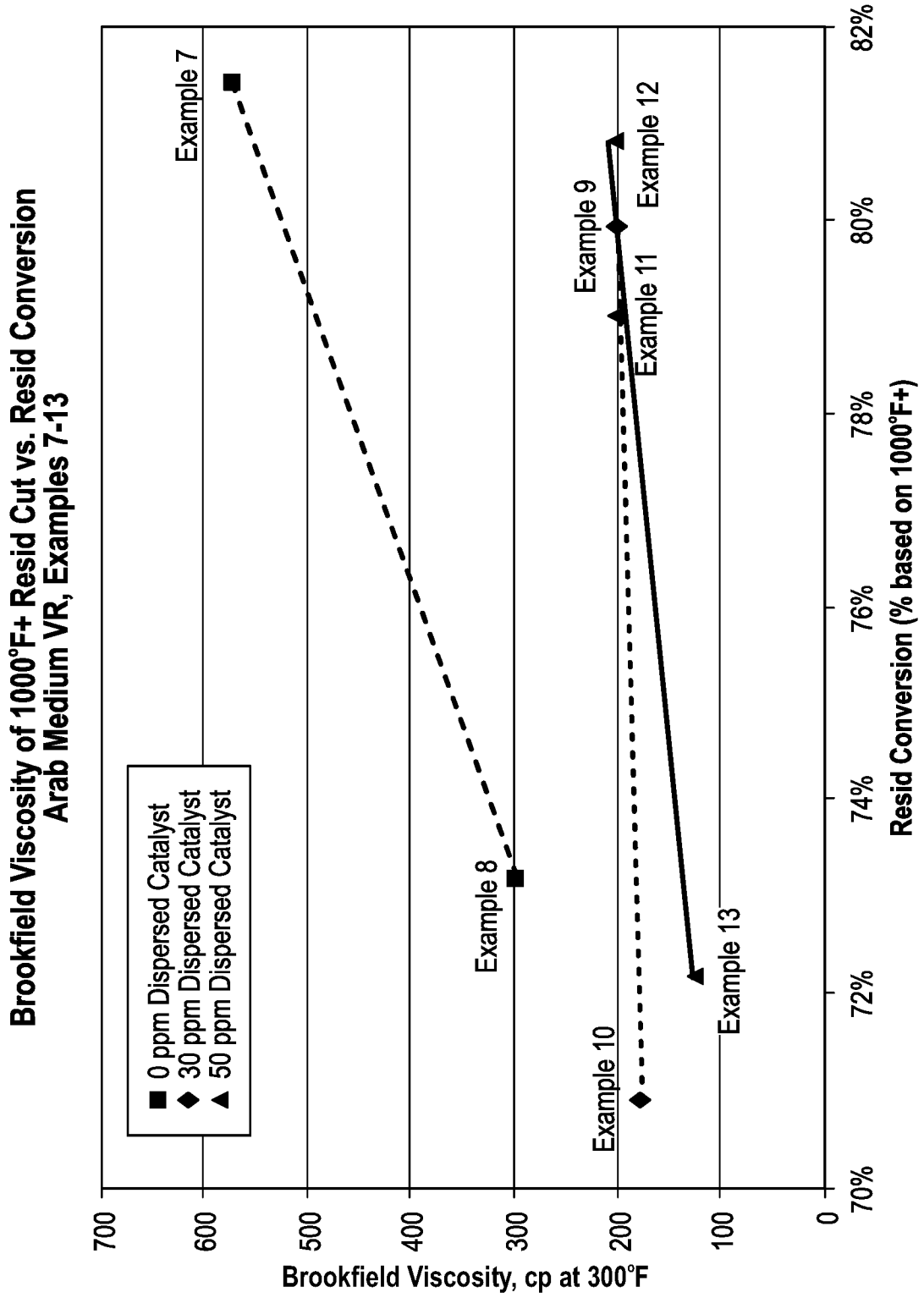

Fig. 12

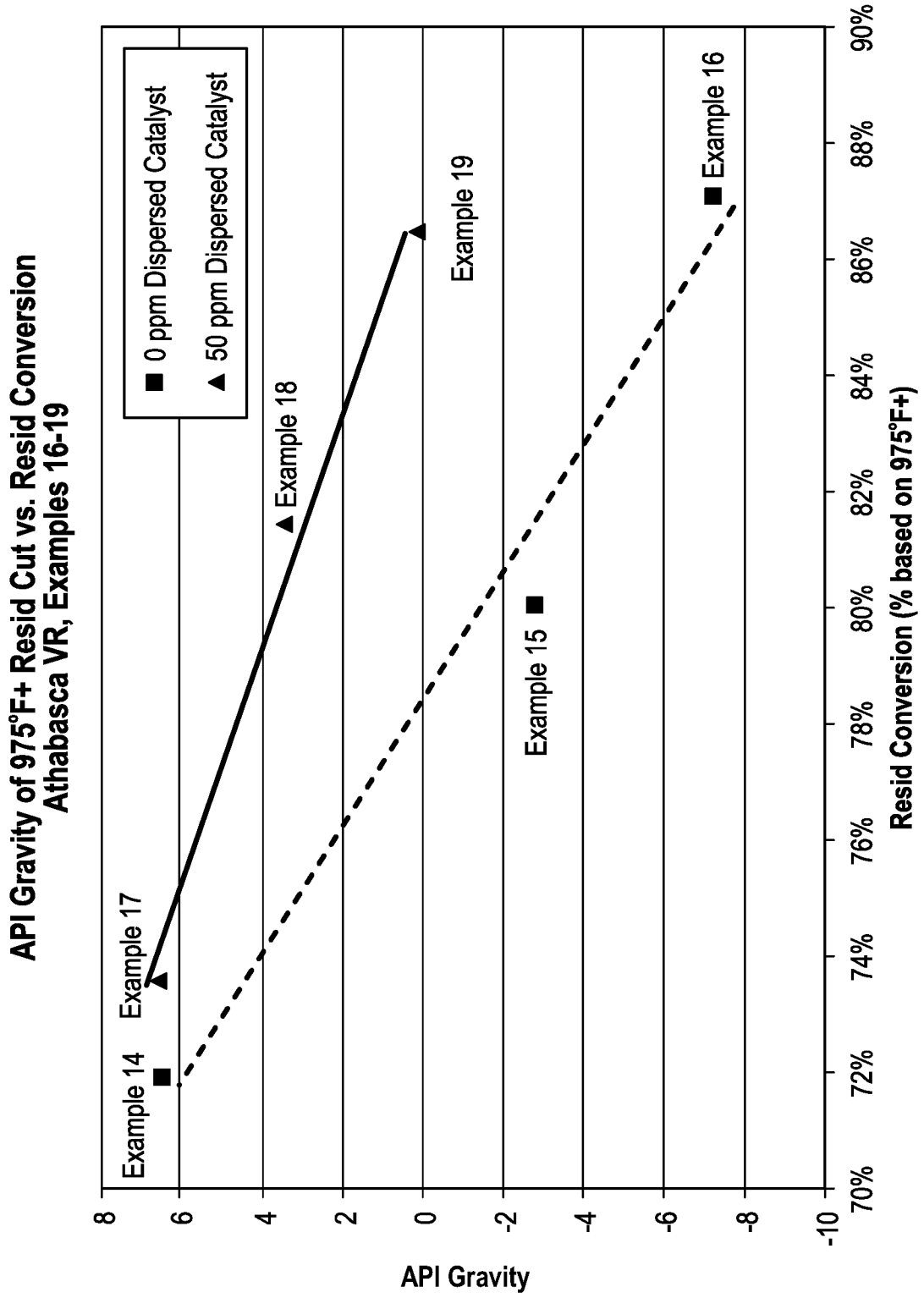

Fig. 13

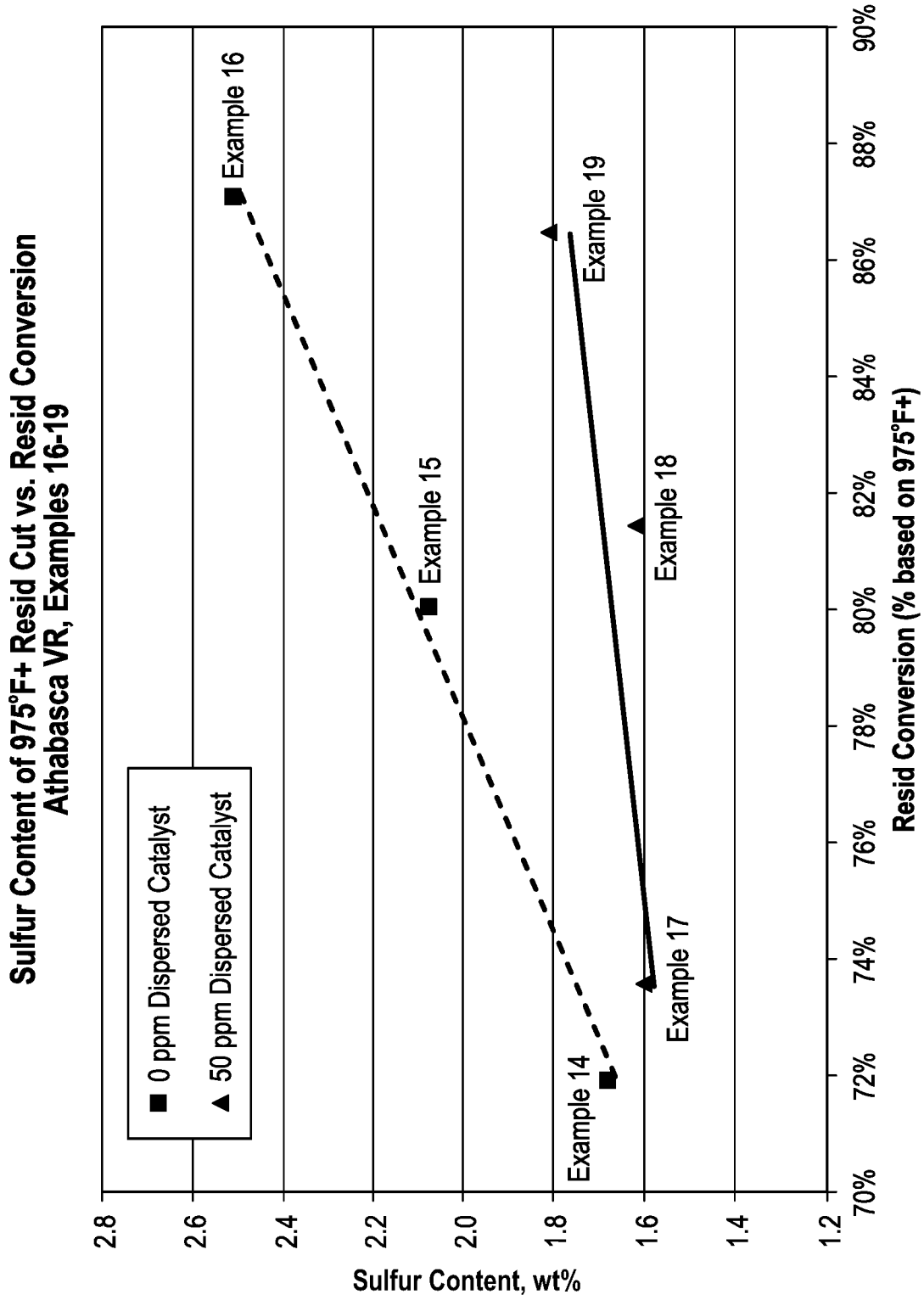

Fig. 14

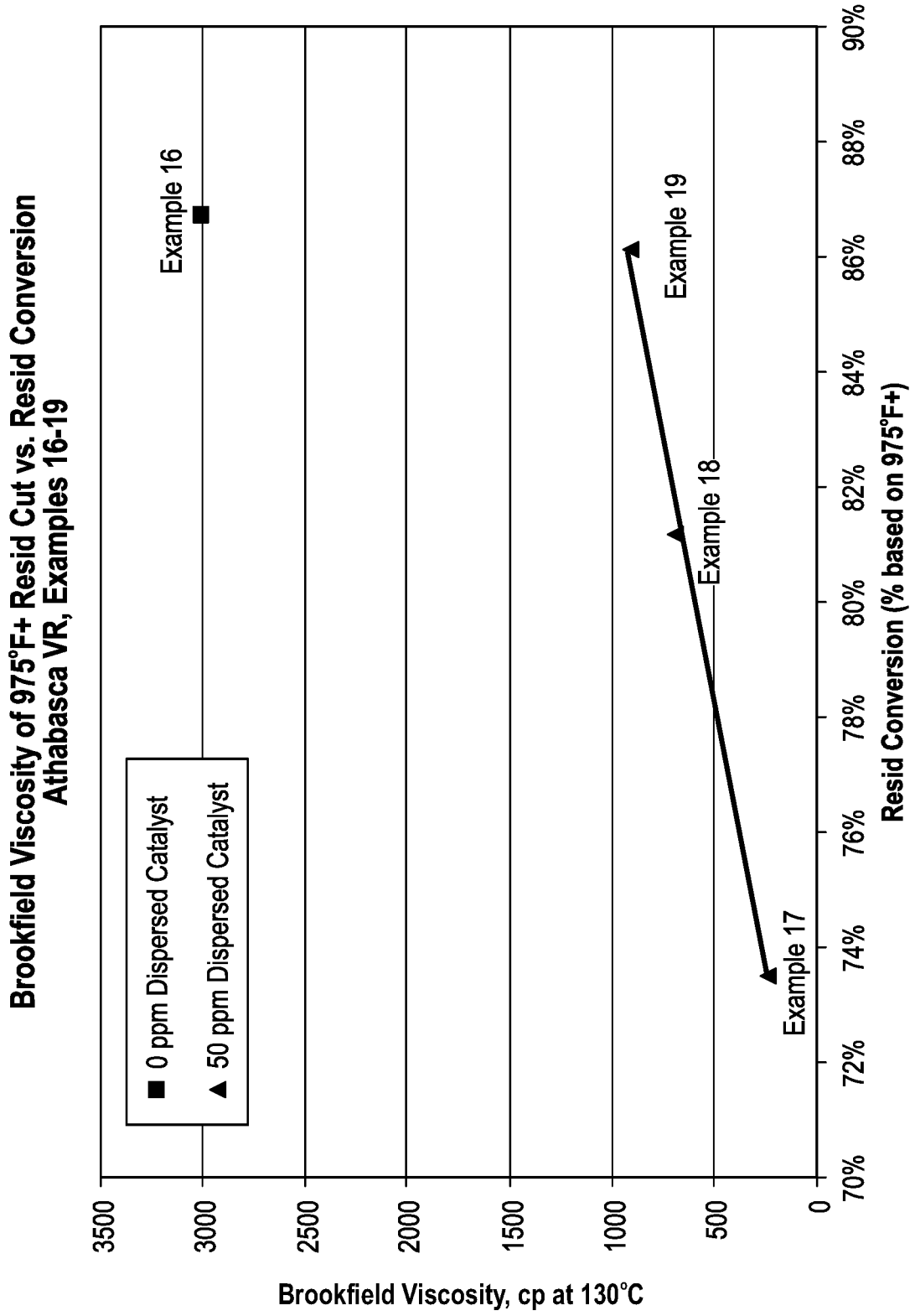

Fig. 15

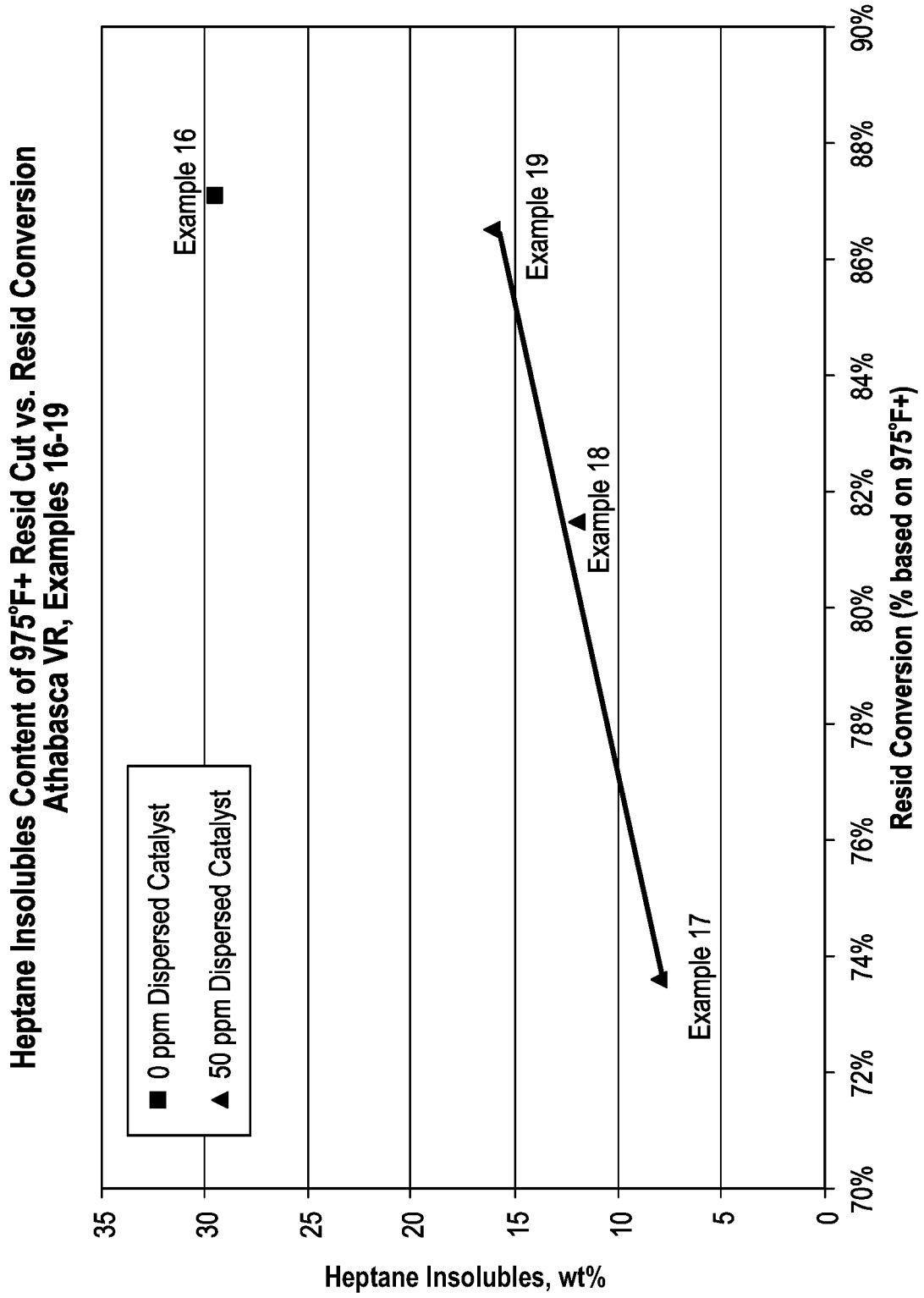

Fig. 16

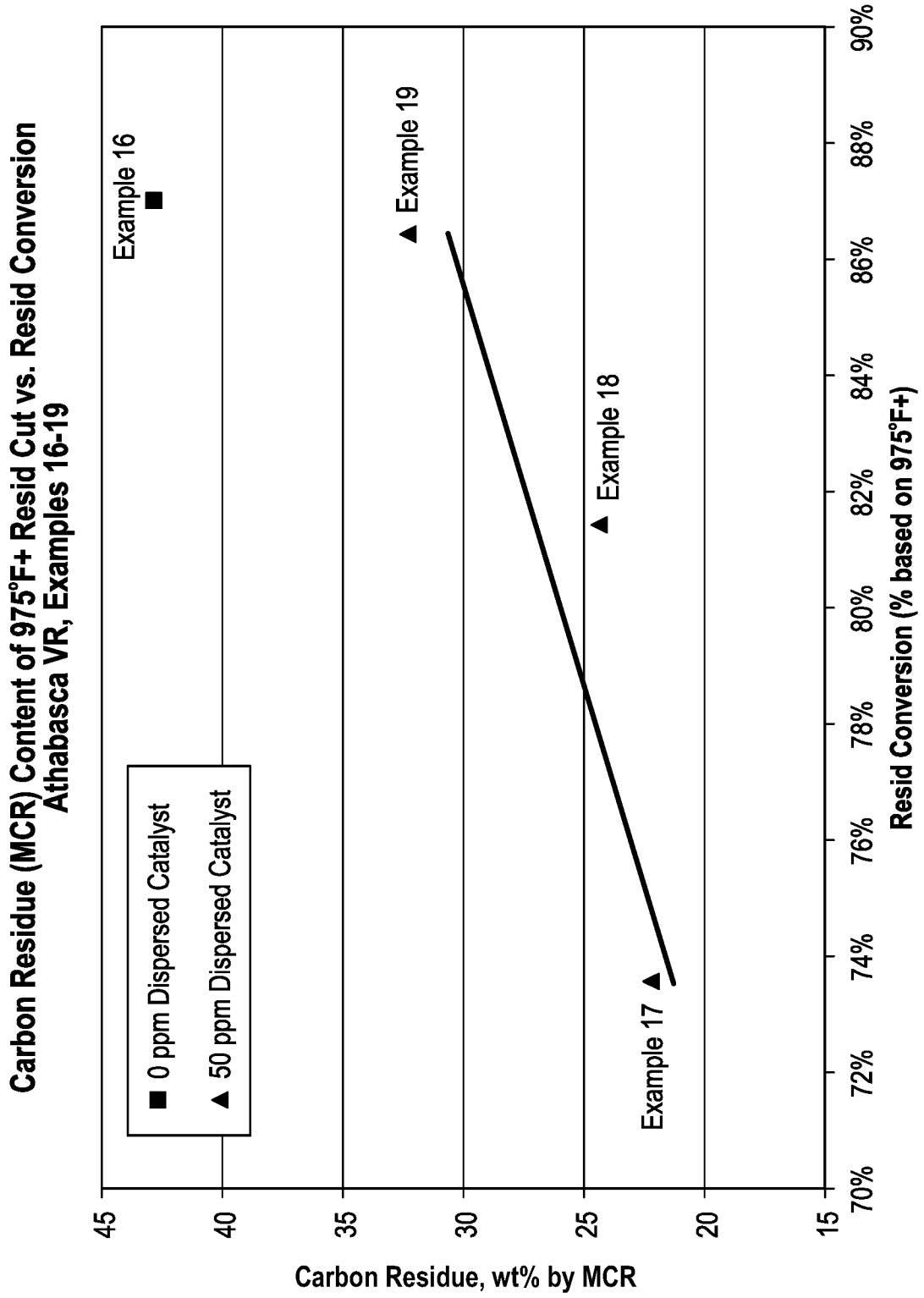

Fig. 17

