

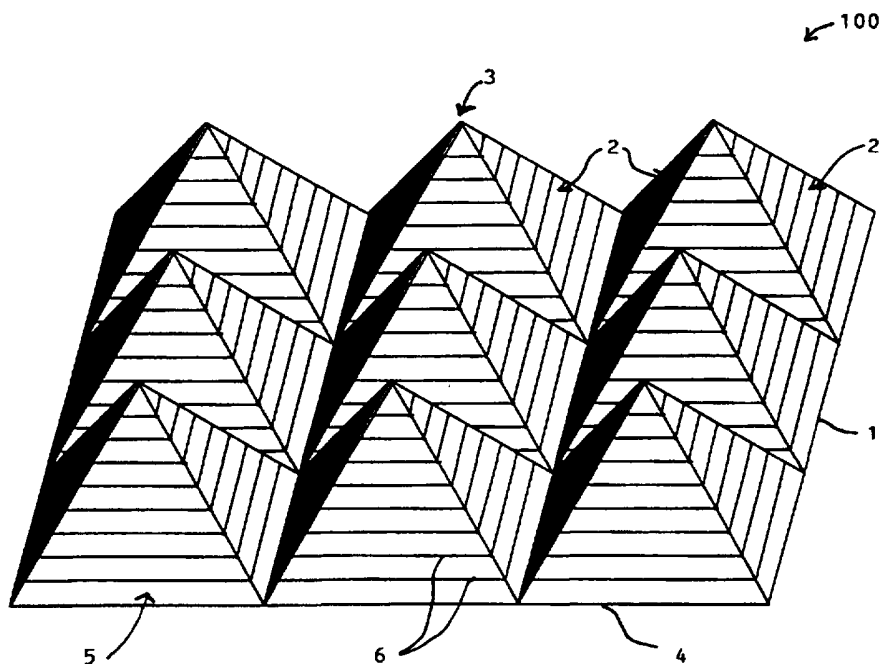

## INTERNATIONAL APPLICATION PUBLISHED UNDER THE PATENT COOPERATION TREATY (PCT)

(51) International Patent Classification <sup>6</sup> : <b>G02B 5/18, B42D 15/10, G06K 19/16</b>	<b>A1</b>	(11) International Publication Number: <b>WO 97/21121</b> (43) International Publication Date: 12 June 1997 (12.06.97)
<p>(21) International Application Number: PCT/GB96/03016</p> <p>(22) International Filing Date: 6 December 1996 (06.12.96)</p> <p>(30) Priority Data: 9524862.1                      6 December 1995 (06.12.95)      GB</p> <p>(71) Applicant (for all designated States except US): THE TECHNOLOGY PARTNERSHIP PLC [GB/GB]; Melbourn Science Park, Cambridge Road, Melbourn, Royston, Hertfordshire SG8 6EE (GB).</p> <p>(72) Inventor; and (75) Inventor/Applicant (for US only): LARGE, Timothy, Andrew [GB/GB]; 9 Byfield Road, Papworth Everard, Cambridge CB3 8UQ (GB).</p> <p>(74) Agent: FLINT, Adam; W.H. Beck, Greener &amp; Co., 7 Stone Buildings, Lincoln's Inn, London WC2A 3SZ (GB).</p>	<p>(81) Designated States: AL, AM, AT, AU, AZ, BA, BB, BG, BR, BY, CA, CH, CN, CU, CZ, DE, DK, EE, ES, FI, GB, GE, HU, IL, IS, JP, KE, KG, KP, KR, KZ, LC, LK, LR, LS, LT, LU, LV, MD, MG, MK, MN, MW, MX, NO, NZ, PL, PT, RO, RU, SD, SE, SG, SI, SK, TJ, TM, TR, TT, UA, UG, US, UZ, VN, ARIPO patent (KE, LS, MW, SD, SZ, UG), Eurasian patent (AM, AZ, BY, KG, KZ, MD, RU, TJ, TM), European patent (AT, BE, CH, DE, DK, ES, FI, FR, GB, GR, IE, IT, LU, MC, NL, PT, SE), OAPI patent (BF, BJ, CF, CG, CI, CM, GA, GN, ML, MR, NE, SN, TD, TG).</p> <p><b>Published</b> <i>With international search report.</i></p>	

(54) Title: DIFFRACTIVE STRUCTURE



## (57) Abstract

A diffractive structure (100) has a substantially planar substrate (1). A set of facets (2) is formed in or on said substrate (1), the plane or planes in which the facets (2) lie being arranged at a non-zero angle to the plane of the substrate (1). Each facet (2) has a diffraction grating (5) formed thereon. The diffractive structure (100) will produce colour over a wide range of viewing and illumination angles.

**FOR THE PURPOSES OF INFORMATION ONLY**

Codes used to identify States party to the PCT on the front pages of pamphlets publishing international applications under the PCT.

<b>AM</b>	Armenia	<b>GB</b>	United Kingdom	<b>MW</b>	Malawi
<b>AT</b>	Austria	<b>GE</b>	Georgia	<b>MX</b>	Mexico
<b>AU</b>	Australia	<b>GN</b>	Guinea	<b>NE</b>	Niger
<b>BB</b>	Barbados	<b>GR</b>	Greece	<b>NL</b>	Netherlands
<b>BE</b>	Belgium	<b>HU</b>	Hungary	<b>NO</b>	Norway
<b>BF</b>	Burkina Faso	<b>IE</b>	Ireland	<b>NZ</b>	New Zealand
<b>BG</b>	Bulgaria	<b>IT</b>	Italy	<b>PL</b>	Poland
<b>BJ</b>	Benin	<b>JP</b>	Japan	<b>PT</b>	Portugal
<b>BR</b>	Brazil	<b>KE</b>	Kenya	<b>RO</b>	Romania
<b>BY</b>	Belarus	<b>KG</b>	Kyrgystan	<b>RU</b>	Russian Federation
<b>CA</b>	Canada	<b>KP</b>	Democratic People's Republic of Korea	<b>SD</b>	Sudan
<b>CF</b>	Central African Republic	<b>KR</b>	Republic of Korea	<b>SE</b>	Sweden
<b>CG</b>	Congo	<b>KZ</b>	Kazakhstan	<b>SG</b>	Singapore
<b>CH</b>	Switzerland	<b>LI</b>	Liechtenstein	<b>SI</b>	Slovenia
<b>CI</b>	Côte d'Ivoire	<b>LJ</b>	Lithuania	<b>SK</b>	Slovakia
<b>CM</b>	Cameroon	<b>LK</b>	Sri Lanka	<b>SN</b>	Senegal
<b>CN</b>	China	<b>LR</b>	Liberia	<b>SZ</b>	Swaziland
<b>CS</b>	Czechoslovakia	<b>LT</b>	Lithuania	<b>TD</b>	Chad
<b>CZ</b>	Czech Republic	<b>LU</b>	Luxembourg	<b>TG</b>	Togo
<b>DE</b>	Germany	<b>LV</b>	Latvia	<b>TJ</b>	Tajikistan
<b>DK</b>	Denmark	<b>MC</b>	Monaco	<b>TT</b>	Trinidad and Tobago
<b>EE</b>	Estonia	<b>MD</b>	Republic of Moldova	<b>UA</b>	Ukraine
<b>ES</b>	Spain	<b>MG</b>	Madagascar	<b>UG</b>	Uganda
<b>FI</b>	Finland	<b>ML</b>	Mali	<b>US</b>	United States of America
<b>FR</b>	France	<b>MN</b>	Mongolia	<b>UZ</b>	Uzbekistan
<b>GA</b>	Gabon	<b>MR</b>	Mauritania	<b>VN</b>	Viet Nam

DIFFRACTIVE STRUCTURE

The present invention relates to a diffractive structure.

5 In many applications, it is desirable to have a diffractive structure having reflective properties which do not depend upon specific limited illumination and viewing angles to produce colour.

10 For example, in security films, security holograms conventionally consist of a thermoformed plastic layer having a reflective aluminium film deposited on the thermoformed layer. The hologram is formed by surface relief. The absence of any absorption within the structure, and the angular sensitivity of a holographic  
15 image, means that under diffuse illumination (such as dull daylight or rooms lit by many lamps), the hologram cannot be seen or can only be seen from within a very narrow range of viewing angles.

20 As a further example, diffractive pigments, such as those disclosed in JP-A-63/172779, would benefit from the use of a diffractive structure which does not appear "washed out" and lacking in colour under normal outdoor viewing conditions. JP-A-63/172779 discloses a pigment which consists of a multiplicity of particles each of which  
25 carries on its surface grooves that form a diffraction grating. Since the gratings on the particles suffer strong angular dependence and have no intrinsic absorption, the diffractive colour effect will only be visible under strong, highly directional, illumination such as direct  
30 sunshine or spotlight illumination. Under diffuse illumination (for example on an overcast day), the pigment as disclosed in JP-A-63/172779 would appear grey.

35 An object of the present invention is to provide a diffractive structure that will produce colour over a wide range of viewing and illumination angles.

-2-

According to a first aspect of the present invention, there is provided a diffractive structure, the structure comprising: a substantially planar substrate; and, a set of facets formed in or on said substrate, the plane or  
5 planes in which the facets lie being arranged at a non-zero angle to the plane of the substrate; the facets having a diffraction grating formed thereon.

According to a second aspect of the present invention, there is provided a diffractive structure, the structure  
10 comprising: a first row of facets which lie in substantially the same first plane; and, a second row of facets which lie in substantially the same second plane, the second plane being at an angle between  $0^\circ$  and  $180^\circ$  to the first plane such that the first row of facets and the  
15 second row of facets oppose each other; each facet having formed thereon a diffraction grating.

According to a third aspect of the present invention, there is provided a method of manufacturing a diffractive structure as described above, the method comprising the  
20 steps of: (A) producing a mould by machining a substrate with repeated passes of a cutting tool, the tool cutting the substrate deeper on each pass of the tool thereby to produce a cut face having machining lines; (B) repeating step (A) to cut a further similar lined face opposite said  
25 first face thereby to produce a groove having machining lines on each opposed face; (C) producing a master from said mould; and, (D) producing the diffractive structure from said master, each facet having formed thereon a  
30 diffraction grating corresponding to the machining lines of the grooves in the mould.

According to a fourth aspect of the present invention, there is provided a method of manufacturing a diffractive structure as described above, the method comprising the  
steps of: (A) producing a mould by anisotropic etching in  
35 a silicon substrate to produce a plurality of facets on the mould; (B) coating the mould with a resist layer; (C)

writing the fine structure of the diffraction grating directly into the resist with an electron beam or an ion beam; (D) producing a master from said mould; and, (E) producing the diffractive structure from said master.

5 Preferred features of the present invention are set out in the claims below.

Thus, in an example of the invention, a prismatic surface structure consisting of an array of substantially planar facets is formed in a polymer layer. These facets  
10 are typically in the region of 1 micron to 100 microns across and are disposed at a predetermined angle to the plane of the polymer layer. A grooved surface, a ruled array of tetrahedra, square pyramids or a corner cube structure (in which the facets are all squares) are  
15 examples of such a prismatic structure. A diffraction structure is formed on the surface of each facet. This smaller structure may be (but is not restricted to) an array of grooves, a crossed grating or a 2-dimensional array of pits and peaks such as the known "motheye"  
20 structure. The smaller structure will have typical dimensions ranging from half the facet size down to 0.1 micron. This structure is preferentially metallised such that it is absorbing at some angles of incidence but produces strong diffraction at other angles.

25 The invention provides a diffractive structure that will produce colour over a wide range of viewing and illumination angles. The diffractive structure can be manufactured in a simple manner using conventional film-forming plastics.

30 Embodiments of the present invention will now be described by way of example with reference to the accompanying drawings, in which:

Fig. 1 is a schematic perspective view of an example of a diffractive structure according to the present  
35 invention;

Fig. 2 is a schematic perspective view of another example of a diffractive structure according to the present invention;

Fig. 3 is a schematic perspective view of a further  
5 example of a diffractive structure according to the present invention;

Fig. 4 is a schematic cross-sectional view through a polymer-filled diffractive structure;

Fig. 5 is a drawing showing a representation of a  
10 light ray incident on the diffractive structure;

Fig. 6 shows the distribution of light rays incident on the surface of a polymer layer of the diffractive structure;

Fig. 7 shows the distribution of light rays incident  
15 within the polymer layer of the diffractive structure;

Fig. 8 shows the distribution of light rays incident on the grating of the diffractive structure;

Fig. 9 shows the distribution of light rays diffracted from the grating of the diffractive structure;

Fig. 10 shows the distribution of light rays leaving  
20 the diffractive structure; and,

Fig. 11 is a CIE (Commission International de l'Eclairage) colour chart showing how the perceived colour varies with viewing angle.

25 In Figure 1, there is shown a diffractive structure  
100 formed by a substrate 1 having an array of facets 2. The facets 2 in this example are provided by the triangular faces 2 of an array of square-base pyramids 3. The pyramids 3 are formed in or on the substrate 1 with their  
30 square bases 4 in the same plane so as to provide respective rows of coplanar facets 2. The length of each side of the square bases 4 of the pyramids 3 may be in the range  $1\mu\text{m}$  to  $100\mu\text{m}$ . Each facet 2 of the pyramids 3 has upon it a diffraction structure such as a ruled diffraction  
35 grating 5 formed by grooves or lines 6 having a regular spacing therebetween. The diffraction grating 5 in this

-5-

example has a period of 300nm (i.e. the spacing between successive lines 6 is 300nm) with a height (i.e. the depth of the lines 6) of about 100nm.

5 Instead of square-base pyramids 3, the two-dimensional facets 2 can be formed as the faces of triangular-base pyramids, regular tetrahedra (see Figure 2), a corner cube structure (in which all or substantially all of the facets are squares), or any other polyhedra or structures which provide an array of identical or substantially similar  
10 facets which project out of the plane of the substrate 1 at an angle between 0° and 90° to the plane of the substrate 1.

15 Instead of a lined diffraction grating as described above, a 2-dimensional array of pits and peaks such as the known "motheye" structure shown in Figure 3 may be used as the diffraction grating 5.

Generally speaking, the length of the bases of the facets 2 may be in the range 1µm to 100µm. The pitch of the diffraction grating 5 formed on a facet 2 may be in the  
20 range of 0.1µm up to about one half of the length of the bases of the facets 2. Thus, for example, where a facet 2 has a base length of 1µm, the pitch of the diffraction grating 5 may be 0.1µm to 0.5µm. Where a facet 2 has a base length of 100µm, the pitch of the diffraction grating  
25 5 may be 0.1µm to 50µm.

Because the diffraction grating structure 5 is at an angle to the normal to the substrate 1, sub-wavelength diffraction gratings can be used, thus providing minimum dispersion (i.e. as little colour variation with angle as  
30 possible) and cut off of some colours which cannot be reflected because their wavelength is too long.

Furthermore, opposing facets 2 allow short wavelength colours to be trapped because they are diffracted at a higher angle with respect to the facets than the longer  
35 wavelengths.

Thus, in the preferred embodiment, there are two mechanisms for colour selection. Dazzling colour effects can be produced even under diffuse lighting and without the use of pigments or dyes.

5 Two-dimensional facet structures as described, such as the faces of arrays of pyramids or tetrahedra, reduce the sensitivity of the diffractive structure 100 to rotation of the structure 100 both in its own plane and out of its plane that would be seen in a one-dimensional facet  
10 structure. Thus, as will be explained further below, the diffractive structure 100 of the present invention will produce colour images under a wide range of lighting conditions and viewing angles.

Using a V-groove (i.e. one-dimensional) structure for  
15 the facets 2 means that the colour effect will depend on the angle of rotation of the substrate in its plane though relative insensitivity of the structure to rotation out of its plane is still retained.

An example of a manufacturing process for producing  
20 the diffractive structure 100 of the present invention will now be described.

Firstly, a non-ferrous material such as brass or copper is machined using a very sharp diamond tool (not shown) to form a mould 100' which is substantially  
25 identical to the diffractive structure 100 to be finally produced. The diamond tip of the tool may have an included angle of 30°. The tool is used to cut a groove to a first depth to provide a cut face having a length equal to the pitch of the diffraction grating 5' to be formed. The tool  
30 is then used to cut the groove to a second depth to cut the face to a length which is twice the pitch of the diffraction grating 5'. This process is repeated until the groove has been cut to the desired depth, the tool being moved deeper into the mould material by a distance such  
35 that the face which is cut is cut by a length which is equal to the pitch of the diffraction grating 5' to be



formed on each successive pass of the tool. As a result of these successively deeper passes of the machining tool, the structure of the diffraction grating 5' composed of the lines 6' is formed from natural machining marks formed during the successive passes of the tool. The groove thus cut will provide a first row of facets 2' in the material. The opposite row of facets 2' and other rows of facets 2', both parallel and orthogonal to the first row of facets 2', are then produced by machining further grooves in a similar manner, the further grooves being parallel and perpendicular to the first groove. The included angle of opposed facets 2' may be 90° for example, though this will depend on the geometry and height of the pyramids 3, tetrahedra or other polyhedra which provide the facets 2.

For speed of manufacture, a series of similar cutting tools can be used to cut parallel rows of grooves to provide facets 2' in a gang fashion. Orthogonal rows can be cut by moving the same or another gang of cutting tools perpendicularly to the first row of facets 2'.

An alternative technique for forming the mould 100' is as follows. The mould 100' having the array 3 of square-base pyramids, triangular-base pyramids, regular tetrahedra, corner cube structure, or other polyhedra or structure, is formed by anisotropic etching in silicon. This provides very flat faces to the facets 2. The mould is then coated with a resist layer. The fine structure which makes up the diffraction grating 5 is then directly written into the resist with an electron beam or an ion beam.

Whichever way the mould 100' is formed, the mould 100' is then electroformed to form a hard master 100", which is a negative of the mould 100' and therefore also a negative of the diffractive structure 100 to be produced. The material of the master 100" needs to be hard enough to allow embossing of a plastics material or other material

-8-

from which the diffractive structure 100 is formed. The master 100" may be nickel or copper for example.

The master 100" is then thermoformed to produce a negative replica of the master 100" in a polymer, in the same way as a conventional commercial hologram. Suitable polymers include polymethyl methacrylate or polycarbonate. The facets 2 on the replica are then metallised with a thin layer of a metal such as chrome, copper, nickel or aluminium to produce the diffractive structure 100 of Figure 1. The metallised layer may be 10 to 50nm thick and is preferably discontinuous over the small scale relief that forms the diffraction grating 5 so that the diffraction grating 5 is partially absorbing or transmitting, and is only weakly specularly reflective.

The structure 100 is preferably then filled with a layer of material 7. The material of the layer 7 is transparent and may be a solvent-drying or chemically-curing polymer, such that the structure 100 has substantially flat and parallel outer surfaces, and the internal structure relief is filled with polymer 7, as shown in Figure 2. The polymer layer 7 may conveniently be the adhesive which is used to fix the diffractive structure 1 to a substrate on which it is mounted.

Light entering the polymer layer 7 is diffracted, absorbed, or reflected by the facets 2. Undiffracted light is either absorbed by the diffraction grating 5 or is specularly reflected. If it is specularly reflected, it passes to the neighbouring facet 2 where again it is absorbed or specularly reflected. If the diffraction grating 5 is designed such that only 10% of light falling upon it can be specularly reflected, only 1% may re-emerge after two such reflections. In the absence of diffraction, the whole structure 100 is therefore substantially non-reflective and appears to the viewer to be black. The diffraction grating 5 can be designed to reduce the amount of light which is specularly reflected by ensuring that the

pitch of the grating is less than the wavelength of light incident on the grating and having the depth of the grating 5 such that the back reflection is cancelled by interference. If the surface of the grating 5 is coated as suggested above with a "lossy" metal (i.e. one with a low reflectivity such as copper, nickel or aluminium) or the metal is discontinuous across the lines 6 of the grating 5, then the incident light is absorbed rather than reflected.

Diffraction will occur when the wavelength of incident 10 light, the angle of incidence of the light, and the period of the diffraction grating 5 have the following relationship:

$$\lambda/\eta = d.\sin(\varphi) + d.\sin(\theta)$$

where  $\lambda$  is the wavelength of the light,  $\eta$  is the refractive 15 index of the polymer 7 filling the diffraction structure,  $\varphi$  and  $\theta$  are the angles of incidence and diffraction, relative to the normal 8 to the facet 2, respectively, and  $d$  is the period of the diffraction grating 5, as shown in Figure 5.

The perceived colour of the structure 100 can be 20 calculated by tracing the paths of the rays which enter and leave the structure 100 by diffraction. Figures 4 to 8 show how the distribution of rays changes as the rays are first refracted at the polymer surface as they enter the polymer, then diffracted at the facet, and refracted again 25 as the rays leave the polymer.

Figure 4 shows a polar plot of the intensity incident on a surface under diffuse illumination, the surface in this case being the outer surface of the polymer layer 7. The intensity drops off with the cosine of the angle of 30 incidence. This dependence is known as Lambertian illumination.

Because of refraction at the air-polymer boundary 9, 15 the range of angles over which the light rays propagate within the polymer layer 7 is reduced, as shown in the polar plot of Figure 5. 35

-10-

As shown in Figure 6, the rays then strike the diffractive grating 5 on the surface of the facets 2 at a range of angles and a proportion of the rays are diffracted. For the sake of reducing the complexity of this description, it is assumed that (i) where diffraction is possible, all of the light is diffracted, and (ii) where diffraction is not possible, the light is absorbed or transmitted by the diffractive grating 5 as described above. It is to be understood, however, that in practice the diffraction efficiency will vary with wavelength and angle.

Some of the light that is diffracted by the diffraction grating 5 on a particular facet 2 is shadowed by the neighbouring facet 2 and does not leave the diffractive structure 100. The polar plot of Figure 7 shows the distribution of the diffracted rays from one facet 2 of the diffractive structure 100 for three different wavelengths. These wavelengths correspond to the peaks of the visual colour response. The solid line represents blue light, the dotted line represents green light and the dashed line represents red light.

As the rays leave the polymer layer 7, they are again refracted at the air-polymer boundary 9. Figure 8 shows the distribution of rays that leave the diffractive structure 100 having been diffracted by one facet 2.

The light rays leaving the one facet 2 can be added to the rays from the neighbouring facet 2 to produce a plot on a standard CIE (Commission International de l'Eclairage) colour chart showing how the perceived colour varies with viewing angle. The chart is reproduced in Figure 9. Over an 80° range of viewing angle (plus or minus 40° from the normal to the polymer layer surface 9), there is very little variation in perceived colour. In this case, the diffractive structure 100 produces a yellow colour under diffuse illumination. Different colours may be produced by altering the facet angles (i.e. the angle of a facet 2 to

-11-

the polymer layer surface 9) and the period  $d$  of the diffraction grating 5.

Thus, the present invention provides a colour diffractive structure 100 which retains a saturated colour when viewed in diffuse lighting over a wide range of viewing angles.

The structure 100 can be mastered by conventional ruling techniques over a large area, and can be formed in a continuous polymer film by a single step embossing process similar to that used in the production of holograms.

The colour primarily depends on the facet angles and the pitch of the diffraction grating, neither of which change significantly during wear. The diffractive structure 100 is therefore ideal for production of large volumes of material. The diffractive structure 100 has particular application in security films on, for example, credit or debit cards where very many substantially identical diffractive structures 100 are required.

An embodiment of the present invention has been described with particular reference to the example illustrated. However, it will be appreciated that variations and modifications may be made to the example described within the scope of the present invention.

-12-

CLAIMS

1. A diffractive structure, the structure (100) comprising:
- 5 a substantially planar substrate (1); and,  
a set of facets (2) formed in or on said substrate (1), the plane or planes in which the facets (2) lie being arranged at a non-zero angle to the plane of the substrate (1);
- 10 the facets (2) having a diffraction grating (5) formed thereon.
2. A structure according to claim 1, wherein the facets (2) lie in substantially the same plane.
- 15
3. A structure according to claim 1, wherein the facets (2) lie in substantially parallel planes.
4. A structure according to claim 3, wherein the facets (2) lie in substantially regularly spaced parallel planes.
- 20
5. A structure according to any of claims 1 to 4, further comprising a second set of facets (2) which lie substantially in a second plane or planes which are at a finite angle to both the first set of facets (2) and the plane of the substrate (1) such that the first and second set of facets substantially oppose each other.
- 25
6. A diffractive structure, the structure (100) comprising:
- 30 a first row of facets (2) which lie in substantially the same first plane; and,  
a second row of facets (2) which lie in substantially the same second plane, the second plane being at an angle between  $0^\circ$  and  $180^\circ$  to the first plane such that the first
- 35

-13-

row of facets (2) and the second row of facets (2) oppose each other;

each facet (2) having formed thereon a diffraction grating (5).

5

7. A structure according to claim 6, wherein the first facets (2) and the second facets (2) are substantially parallel.

10 8. A structure according to claim 6 or claim 7, comprising further rows of facets (2) which lie in respective planes substantially orthogonal to the first plane.

15 9. A structure according to any of claims 6 to 8, comprising further rows of facets (2) which lie in respective planes substantially parallel to the first plane.

20 10. A structure according to any of claims 6 to 9, wherein the facets (2) are formed in or on a substantially planar substrate (1), the planes in which the facets (2) lie being at an angle between  $0^\circ$  and  $180^\circ$  to the plane of the substrate.

25

11. A structure according to any of claims 1 to 10, wherein the facets (2) are provided by the faces of square-base pyramids (3).

30 12. A structure according to any of claims 1 to 10, wherein the facets (2) are provided by the faces of cubes.

13. A structure according to any of claims 1 to 10, wherein the facets (2) are provided by a corner cube structure.

35

-14-

14. A structure according to any of claims 1 to 10,  
wherein the facets (2) are provided by the faces of  
tetrahedra.
- 5 15. A structure according to any of claims 1 to 10,  
wherein the tetrahedra are regular tetrahedra.
16. A structure according to any of claims 1 to 15,  
wherein the diffraction grating (5) is provided by series  
10 of grooves (6) across the facets (2).
17. A structure according to any of claims 1 to 15,  
wherein the diffraction grating (5) is provided by a  
crossed grating on the facets (2).
- 15 18. A structure according to any of claims 1 to 15,  
wherein the diffraction grating (5) is provided by an array  
of pits and peaks on the facets (2).
- 20 19. A structure according to any of claims 1 to 18,  
wherein the typical periodicity of the diffraction grating  
(5) is less than one wavelength of visible light.
- 25 20. A structure according to any of claims 1 to 19,  
wherein the volume between the facets (2) is filled with a  
transparent material (7).
- 30 21. A structure according to any of claims 1 to 20,  
wherein the facets (2) are formed of a polymeric material  
coated with a layer of metal.
22. A structure according to claim 21, wherein the metal  
layer is discontinuous over the diffraction grating (5) on  
the facets (2).

35



23. A security film including a diffractive structure (100) according to any of claims 1 to 22.

24. A method of manufacturing a diffractive structure  
5 according to any of claims 1 to 23, the method comprising the steps of:

(A) producing a mould by machining a substrate with repeated passes of a cutting tool, the tool cutting the substrate deeper on each pass of the tool thereby to  
10 produce a cut face having machining lines;

(B) repeating step (A) to cut a further similar lined face opposite said first face thereby to produce a groove having machining lines on each opposed face;

(C) producing a master from said mould; and,

15 (D) producing the diffractive structure from said master, each facet having formed thereon a diffraction grating corresponding to the machining lines of the grooves in the mould.

20 25. A method according to claim 24, wherein further lined grooves parallel to the first lined groove are cut by repeating steps (A) and (B).

25 26. A method according to claim 24 or claim 25, wherein further lined grooves orthogonal to the first lined groove are cut by repeating steps (A) and (B).

27. A method according to claim 24, wherein further lined grooves parallel to the first lined groove are  
30 simultaneously cut with the first lined groove by a ganged series of cutting tools.

28. A method according to claim 24 or claim 27, wherein further lined grooves orthogonal to the first lined groove  
35 are simultaneously cut by a ganged series of cutting tools.

29. A method of manufacturing a diffractive structure according to any of claims 1 to 23, the method comprising the steps of:

5 (A) producing a mould by anisotropic etching in a silicon substrate to produce a plurality of facets on the mould;

(B) coating the mould with a resist layer;

10 (C) writing the fine structure of the diffraction grating directly into the resist with an electron beam or an ion beam;

(D) producing a master from said mould; and,

(E) producing the diffractive structure from said master.

15 30. A method according to any of claims 24 to 29, wherein the master is produced by electroforming the mould.

20 31. A method according to any of claims 24 to 30, wherein the diffractive structure is produced by thermoforming the master.

25 32. A method according to claim 31, further comprising the step of coating the facets of the diffractive structure with a metal layer.

33. A method according to claim 32, wherein the metal layer is discontinuous over the diffraction grating on the facets.

Figure 1

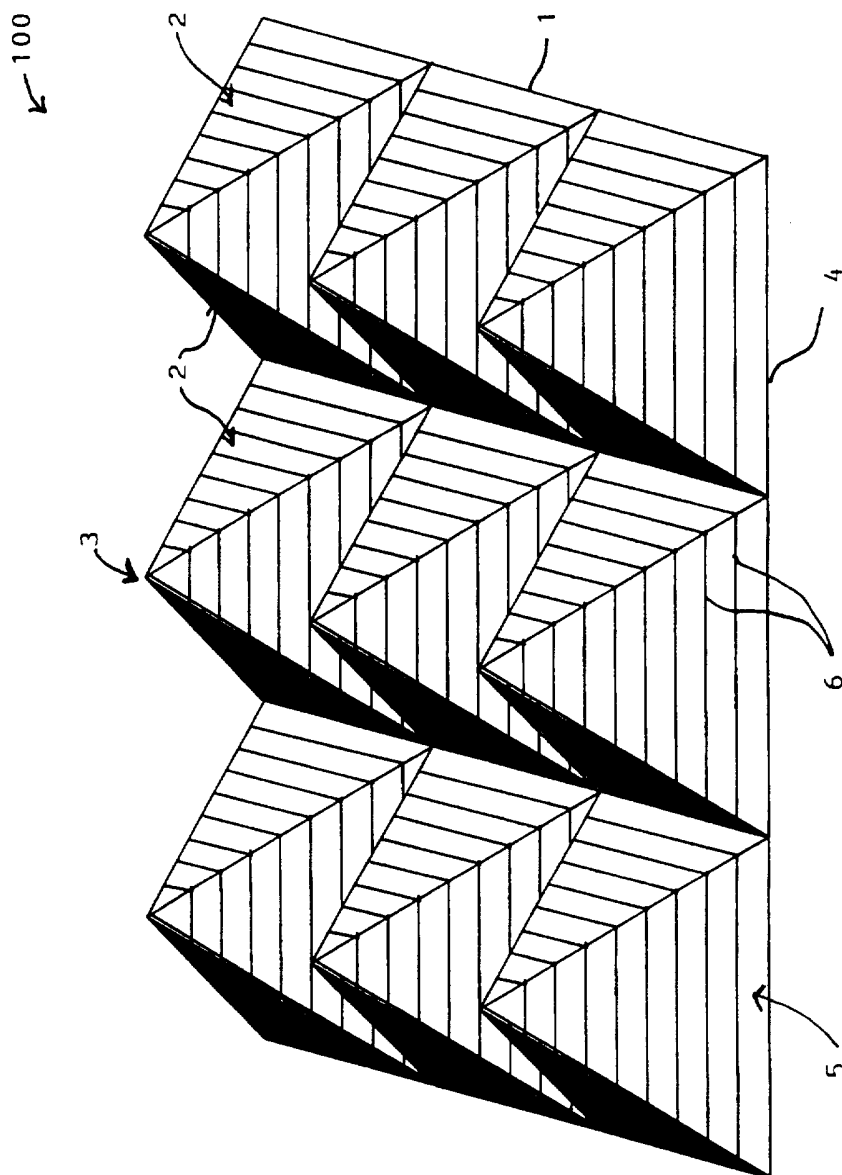
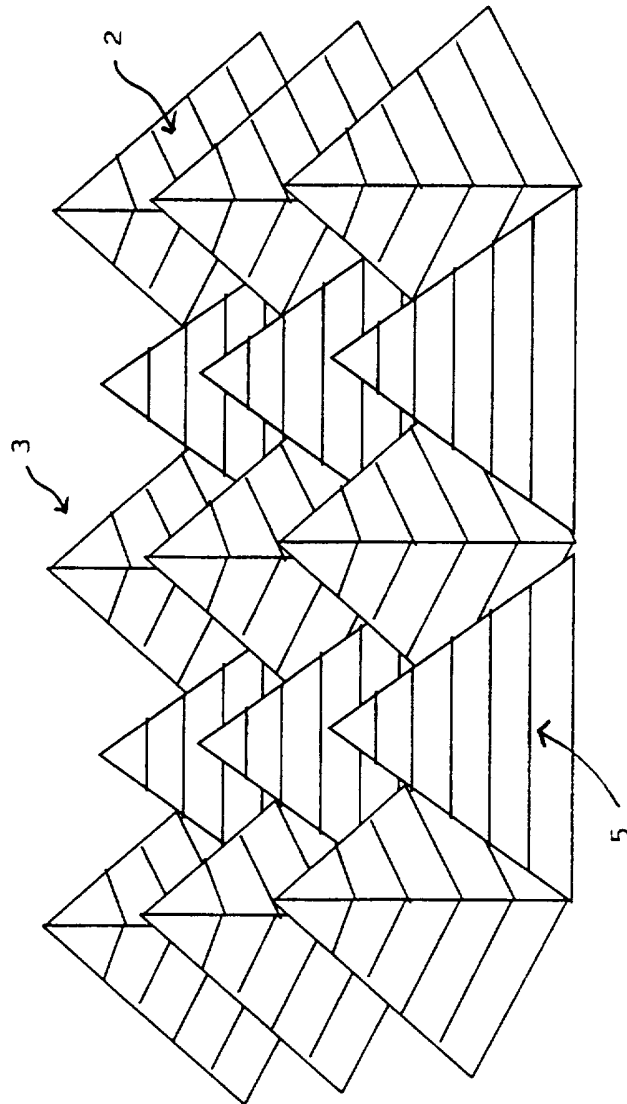

Figure 2



3/11

Figure 3

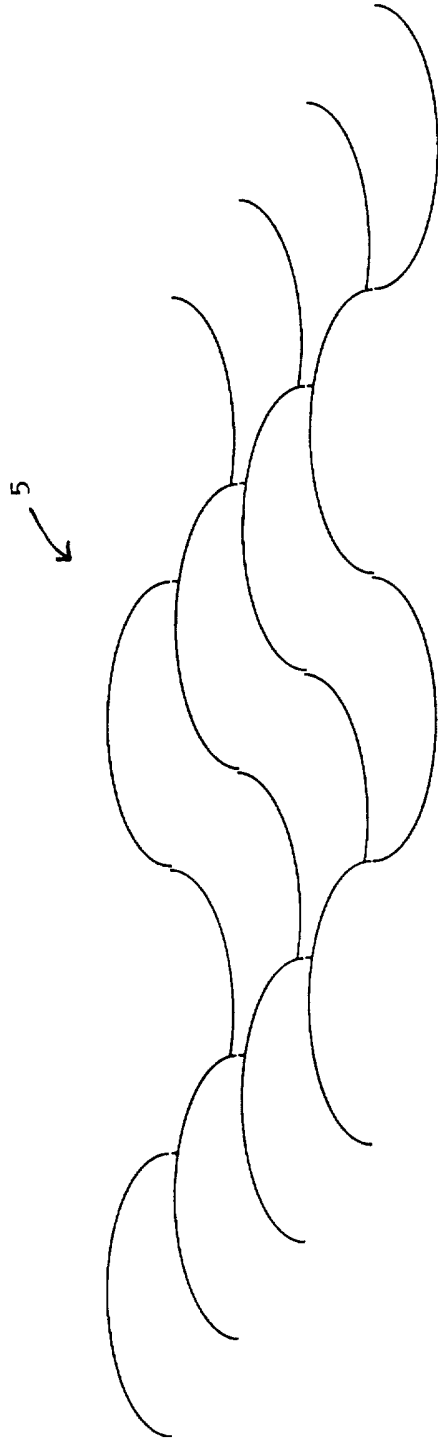

Figure 4

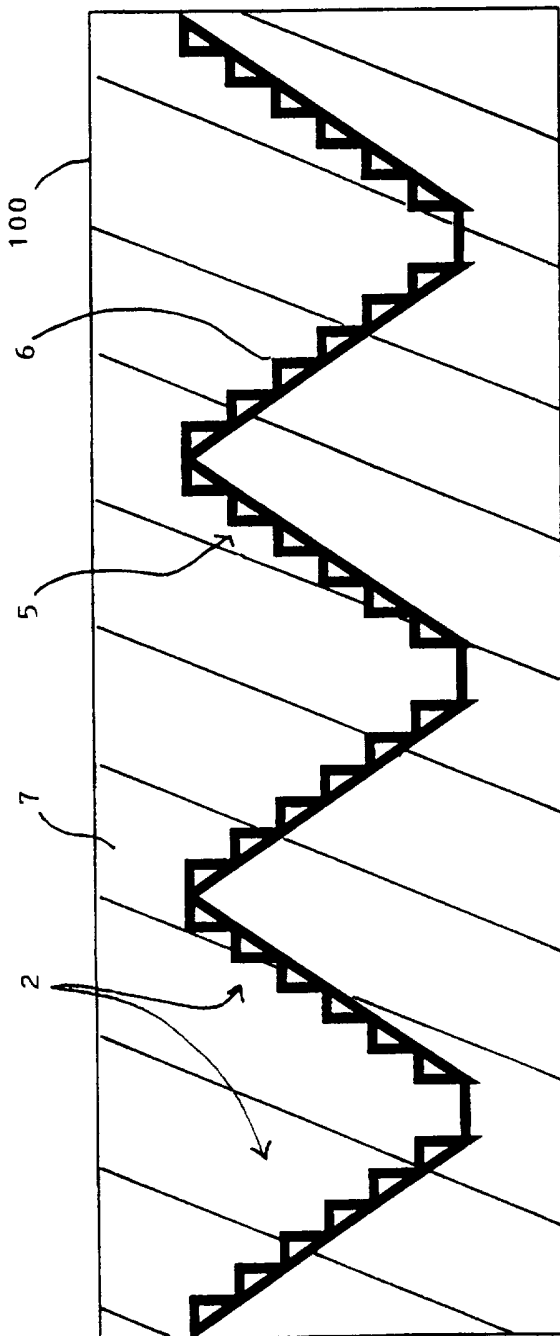
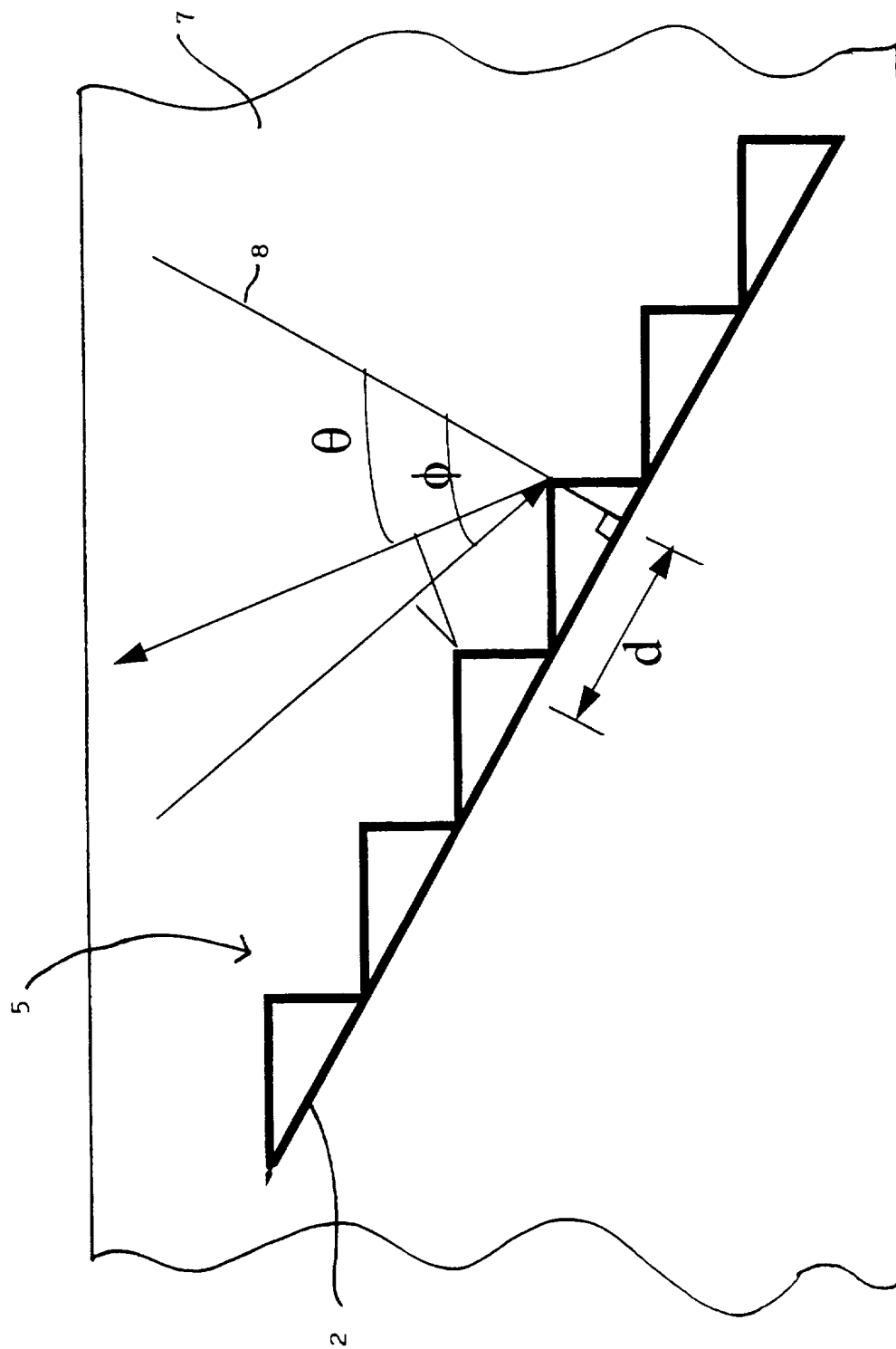
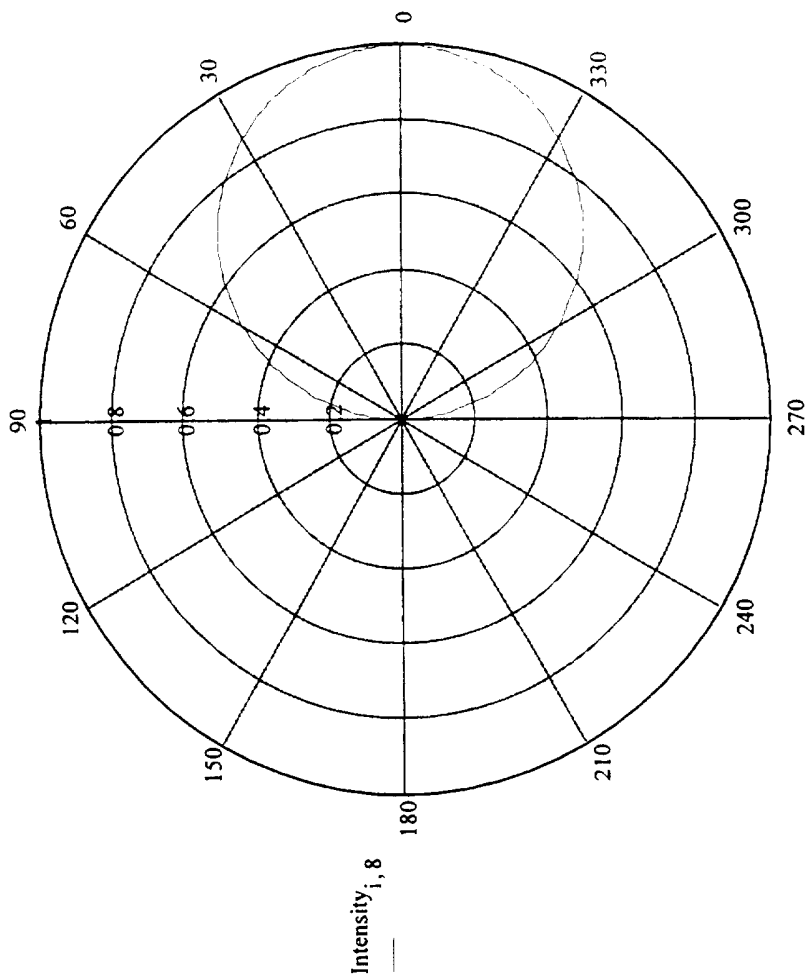

Figure 5



6/11



2·π·Angle<sub>incidence</sub><sub>i</sub>  
360

Figure 6

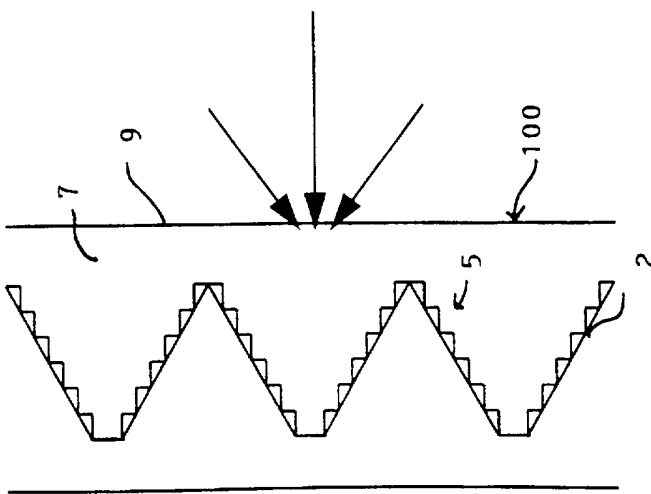



7/11

Figure 7

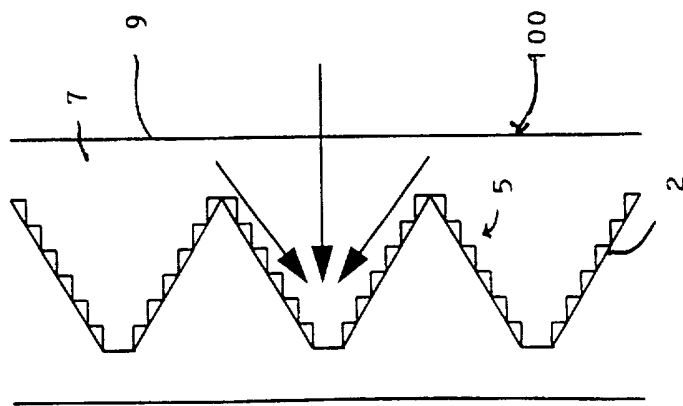
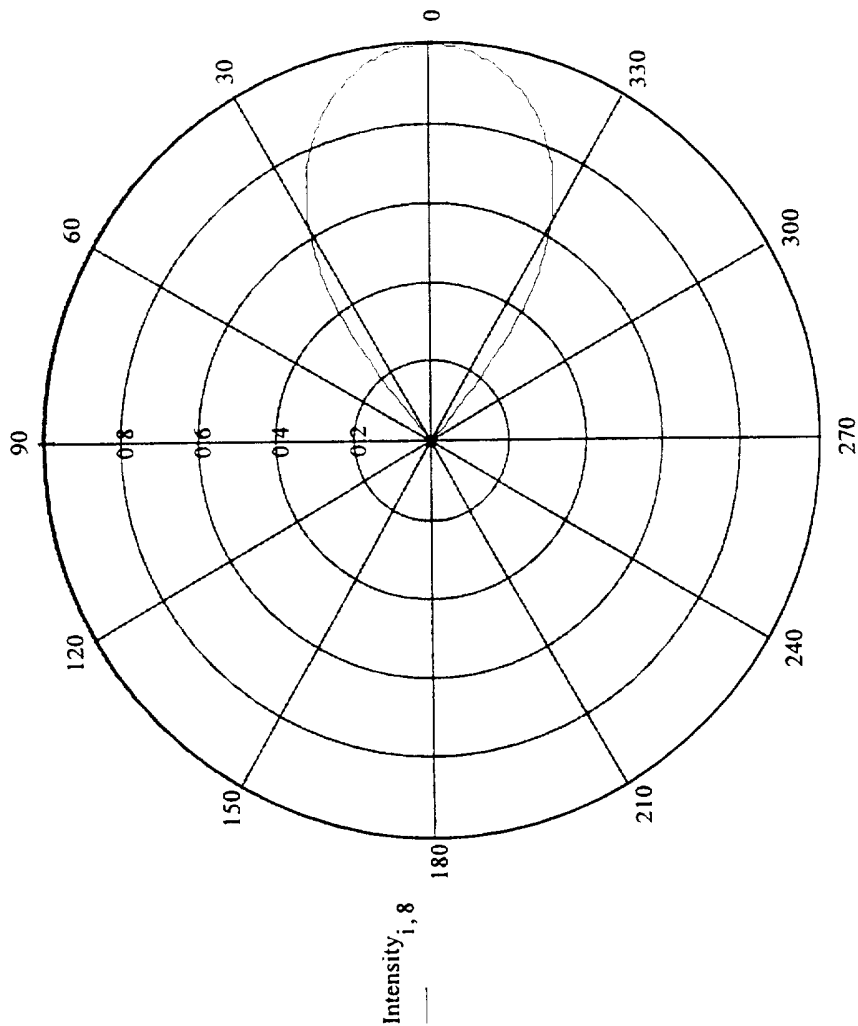

2· $\pi$ ·Angle\_refraction\_i  
360

8/11

Figure 8

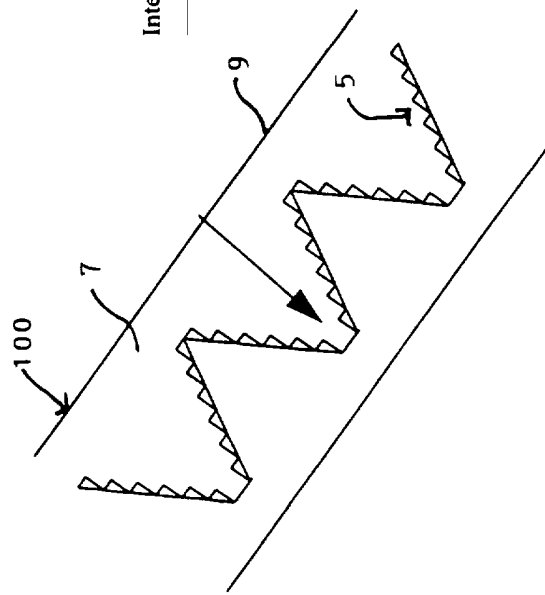
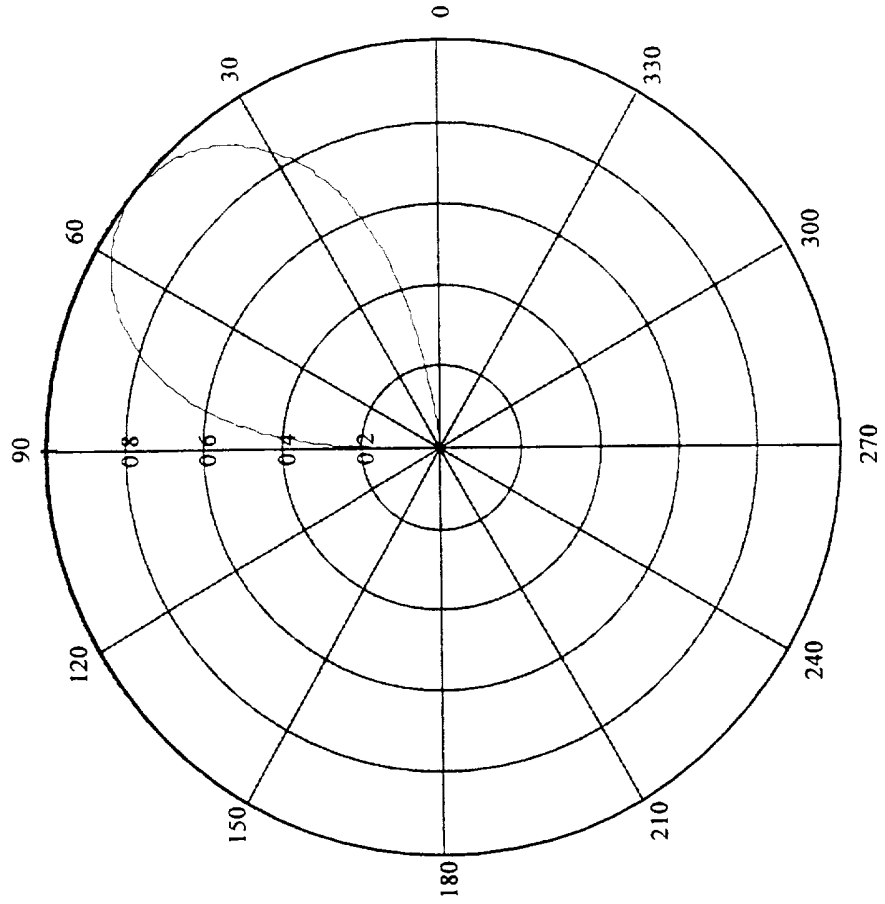

Intensity,  $i, 8$

2·π·Angle\_incidence\_on\_grating

9/11

Figure 9

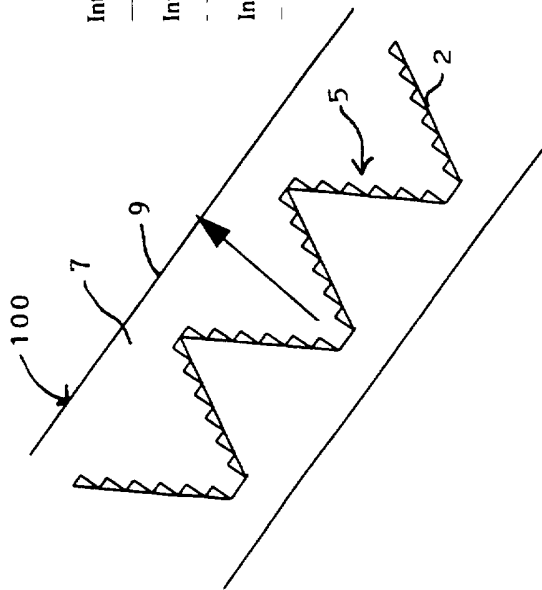
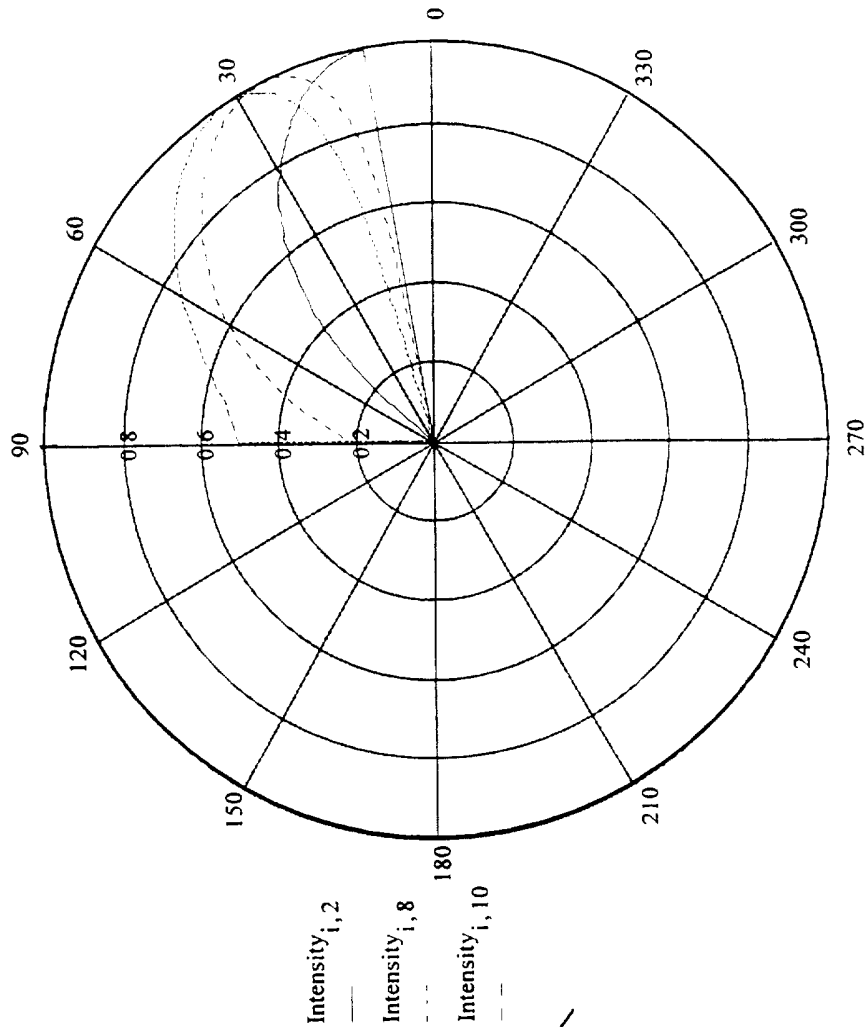

$2 \cdot \pi \cdot \text{Angle\_diffraction}_{i,2}$     $2 \cdot \pi \cdot \text{Angle\_diffraction}_{i,8}$     $2 \cdot \pi \cdot \text{Angle\_diffraction}_{i,10}$

10/11

Figure 10

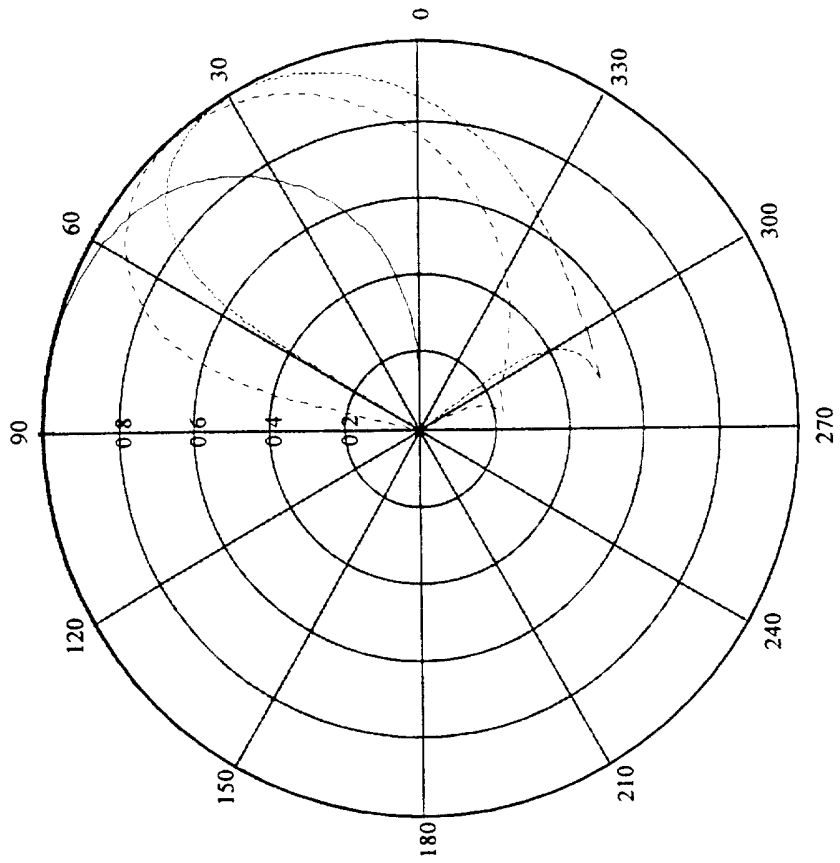

Intensity<sub>i,2</sub>  
 Intensity<sub>i,8</sub>  
 Intensity<sub>i,10</sub>

$$\frac{2 \cdot \pi}{360} \cdot \text{Angle\_exit}_{i,2} \cdot \frac{2 \cdot \pi}{360} \cdot \text{Angle\_exit}_{i,8} \cdot \frac{2 \cdot \pi}{360} \cdot \text{Angle\_exit}_{i,10}$$

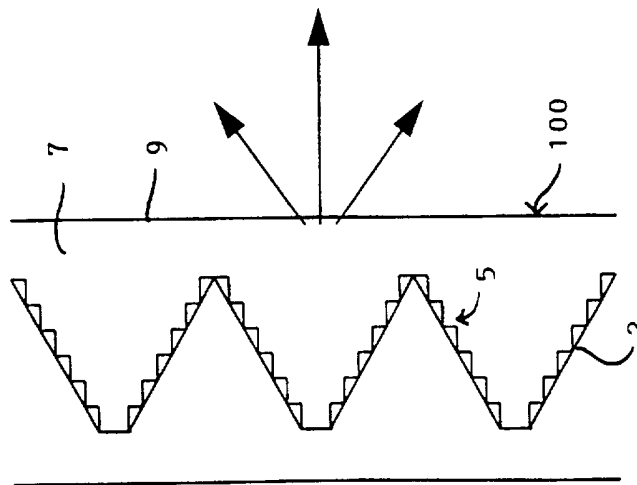
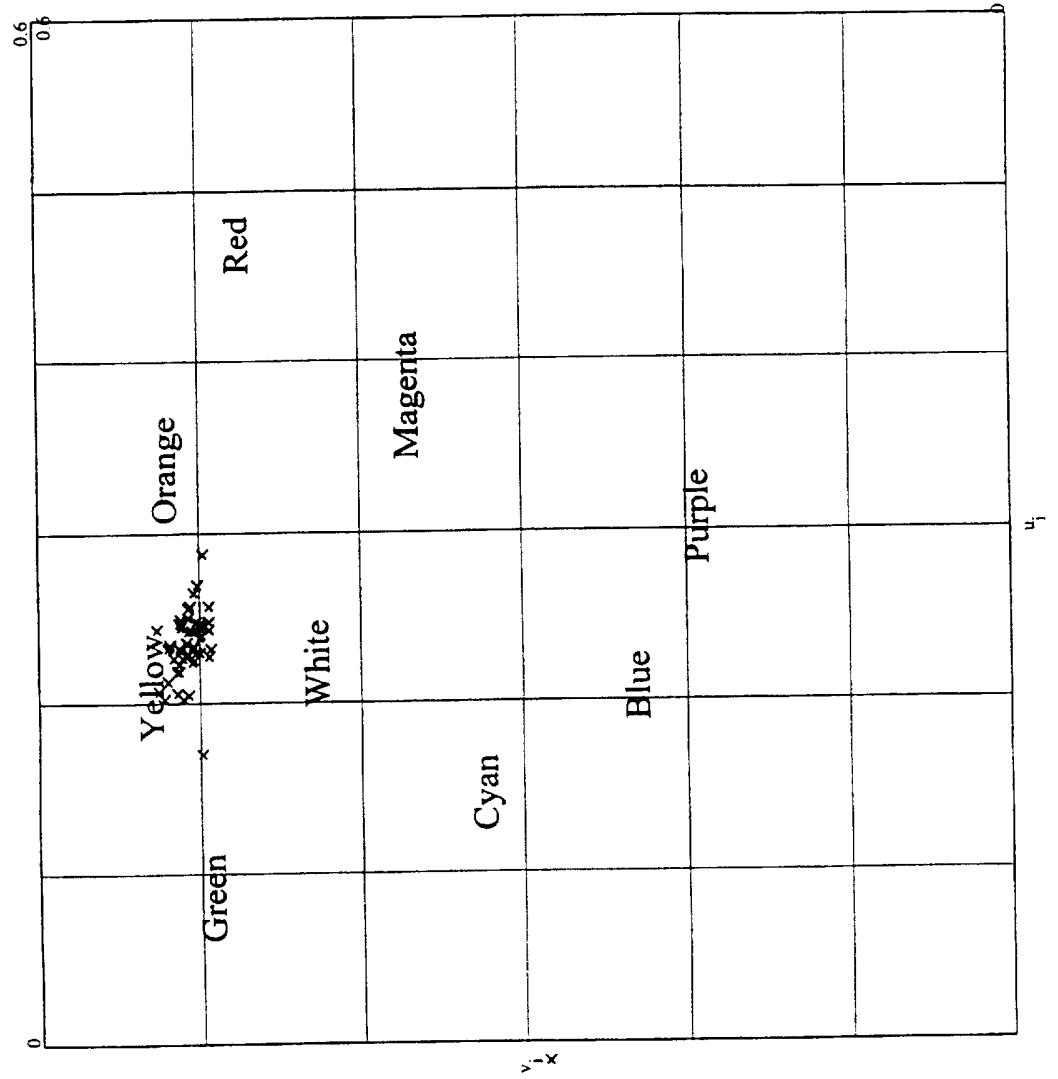

Figure 11



# INTERNATIONAL SEARCH REPORT

International Application No  
PCT/GB 96/03016

A. CLASSIFICATION OF SUBJECT MATTER  
IPC 6 G02B5/18 B42D15/10 G06K19/16

According to International Patent Classification (IPC) or to both national classification and IPC

B. FIELDS SEARCHED

Minimum documentation searched (classification system followed by classification symbols)  
IPC 6 G02B B42D G06K

Documentation searched other than minimum documentation to the extent that such documents are included in the fields searched

Electronic data base consulted during the international search (name of data base and, where practical, search terms used)

C. DOCUMENTS CONSIDERED TO BE RELEVANT

Category *	Citation of document, with indication, where appropriate, of the relevant passages	Relevant to claim No.
X A	EP 0 057 271 A (LANDIS & GYR AG) 11 August 1982 see page 20, line 8 - line 15  see figure 32	1,3,5, 20,23 6,7,9, 10,16, 18,21, 24,29
P,X P,A	EP 0 715 189 A (FRANCE TELECOM) 5 June 1996 see the whole document	1,3-5,16  6,7,9, 10,18,21
A	DE 42 25 007 A (MUELLER HELMUT FRANK OTTOMAR P) 3 February 1994 see the whole document	1,6,11
	-/--	

Further documents are listed in the continuation of box C.       Patent family members are listed in annex.

\* Special categories of cited documents :

<p>"A" document defining the general state of the art which is not considered to be of particular relevance</p> <p>"E" earlier document but published on or after the international filing date</p> <p>"L" document which may throw doubts on priority claim(s) or which is cited to establish the publication date of another citation or other special reason (as specified)</p> <p>"O" document referring to an oral disclosure, use, exhibition or other means</p> <p>"P" document published prior to the international filing date but later than the priority date claimed</p>	<p>"T" later document published after the international filing date or priority date and not in conflict with the application but cited to understand the principle or theory underlying the invention</p> <p>"X" document of particular relevance; the claimed invention cannot be considered novel or cannot be considered to involve an inventive step when the document is taken alone</p> <p>"Y" document of particular relevance; the claimed invention cannot be considered to involve an inventive step when the document is combined with one or more other such documents, such combination being obvious to a person skilled in the art.</p> <p>"&amp;" document member of the same patent family</p>
--	--

Date of the actual completion of the international search  18 March 1997	Date of mailing of the international search report  26.03.97
--	--

Name and mailing address of the ISA European Patent Office, P.B. 5818 Patentlaan 2 NL - 2280 HV Rijswijk Tel. (+ 31-70) 340-2040, Tx. 31 651 epo nl, Fax (+ 31-70) 340-3016	Authorized officer  Ward, S
---	-----------------------------------

# INTERNATIONAL SEARCH REPORT

Int. l. Application No  
PCT/GB 96/03016

C.(Continuation) DOCUMENTS CONSIDERED TO BE RELEVANT		
Category	Citation of document, with indication, where appropriate, of the relevant passages	Relevant to claim No.
A	<p>JOURNAL OF PHYSICS E SCIENTIFIC INSTRUMENTS., vol. 3, no. 12, December 1970, BRISTOL GB, pages 953-961, XP002027792 LOEWEN E G: "Diffraction Gratings for Spectroscopy" see the whole document ---</p>	24
A	<p>JOURNAL OF VACUUM SCIENCE AND TECHNOLOGY: PART B, vol. 5, no. 1, January 1987, NEW YORK US, pages 33-36, XP002027793 TERUHIRO SHIONO ET AL: "Computer controlled electron beam writing system for thin film micro optics" see the whole document ---</p>	29
A	<p>SENSORS AND ACTUATORS A, vol. A51, no. 1, 1 October 1995, pages 77-80, XP000545377 KLUMPP A ET AL: "ANISOTROPIC ETCHING FOR OPTICAL GRATINGS" see the whole document -----</p>	29

# INTERNATIONAL SEARCH REPORT

Information on patent family members

International Application No

PCT/GB 96/03016

Patent document cited in search report	Publication date	Patent family member(s)	Publication date
EP 0057271 A	11-08-82	AT 9851 T	15-10-84
		JP 1369990 C	25-03-87
		JP 57139872 A	30-08-82
		JP 61034192 B	06-08-86
		US 4537504 A	27-08-85
EP 0715189 A	05-06-96	FR 2726660 A	10-05-96
		JP 8211216 A	20-08-96
DE 4225007 A	03-02-94	NONE	