



(12) **EUROPEAN PATENT APPLICATION**

(43) Date of publication: **25.10.2000 Bulletin 2000/43** (51) Int Cl.7: **E03D 9/03**

(21) Application number: **99830224.4**

(22) Date of filing: **19.04.1999**

(84) Designated Contracting States:
**AT BE CH CY DE DK ES FI FR GB GR IE IT LI LU
MC NL PT SE**
Designated Extension States:
AL LT LV MK RO SI

- **Cira', Riccardo**
20153 Milano (IT)
- **Di Bono, Giuseppe**
70124 Bari (IT)

(71) Applicant: **Manitoba Italia S.p.A.**
20124 Milano (IT)

(74) Representative: **Modiano, Guido, Dr.-Ing. et al**
Modiano & Associati SpA
Via Meravigli, 16
20123 Milano (IT)

(72) Inventors:
• **Massarani, Giorgio**
20133 Milano (IT)

(54) **Automatic dispenser, particularly for detergent and deodorant liquid for toilet bowls**

(57) An automatic dispenser, particularly of deodorant and detergent liquid for toilet bowls, comprising a supporting element (2) which can be applied to the rim of a toilet bowl (25), in a region affected by the flow of flushing water, and forms means (40) for supporting a container (20) of viscous liquid which is arranged so that

its dispensing outlet (30) is directed downward and is spaced from the inner bottom of the supporting element (2). A region is provided, at the inner bottom, for collecting water up to a level with a preset distance from a plug (31) which is placed on the dispensing outlet (30) and is provided with gauged holes (32) for the release of the viscous liquid in controlled doses.

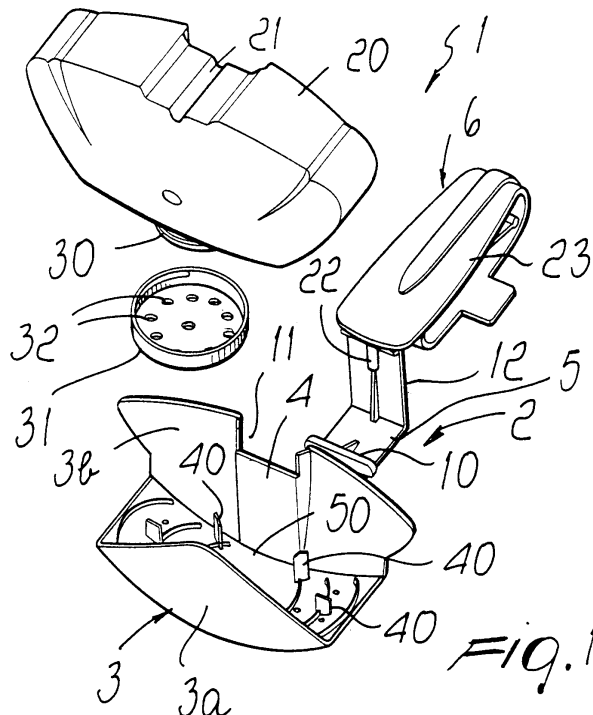

Description

[0001] The present invention relates to an automatic dispenser particularly for detergent and deodorant liquid for toilet bowls.

[0002] It is known that toilet bowls or lavatories are cleaned and deodorized by using products in solid form, such as blocks to be placed in the flushing cistern or tablets to be hung from the rim of the bowl and which, by means of the appropriately provided hook connected to the frame in which the block is placed, expose such block to the flow of the flushing water.

[0003] At each flush, such blocks and tablets release into the water their active principles, such as detergents, disinfectants and whitening agents, and diffuse fragrances into the surrounding environment.

[0004] One limitation of these products is constituted by the fact that the amount of fragrance that can be included in the mix that constitutes the solid block is limited to low percentages and accordingly the fragrance-release capacity is depleted much faster than the block solubilizes; accordingly, there are two different stages of the life of the product during its use, namely a first detergent and scenting stage and a second exclusively detergent stage.

[0005] Another limitation of conventional blocks is constituted by the fact that the components that are present on the surface of the block remain in contact with the flushing water and if they are substances susceptible of hydrolysis they react with the water and lose their effectiveness in the time between one flush and the next; this behavior is typical of the organic chloroderivatives often used in blocks as agents for releasing chloride, with a whitening and disinfectant function.

[0006] In order to try to obviate the shortcomings of conventional blocks and in particular the limited persistence of the fragrance during the active life of the product, detergent and fragrance-releasing products have been marketed which are designed to be hung from the rim of the toilet bowl and are constituted by containers of liquids having different viscosities which, by means of different operating mechanisms, release a dose of the liquid at each flush.

[0007] Various technical solutions have been proposed for adjusting the flow of the liquid that leaves the container, allowing its dispensing only during flushing and stopping its release in the interval between one flush and the next.

[0008] Accordingly, for example, EP-538957 provides for a reservoir of liquid which is hung by means of a hook under the rim of the toilet bowl and allows its content to permeate through a porous mass whose shape is such that it is struck by the flushing water; the porous mass adapted to the mouth of the reservoir of liquid acts as a regulator for the flow of the liquid and as a fragrance diffuser.

[0009] This embodiment has been found to be sometimes less than ideal because the amount of detergent

and fragrance-releasing liquid that can be emitted is not constant.

[0010] EP-785315 provides for a liquid reservoir which is hung from the rim of the toilet bowl and allows the content to flow out and an equivalent inflow of air through the discharge opening through a plastic coupling whose shape allows it to penetrate in the discharge opening and convey liquid and air through mutually independent channels. The discharged liquid is distributed, by means of a siphon-shaped chamber, onto a porous plate which is struck by the flushing water; with this solution, at each flush the dose of liquid on the plate is removed and allows the siphon-shaped chamber to refill.

[0011] This system has good operating characteristics but is constructively very complicated, as shown by the large number of parts that compose the device.

[0012] DE-19520145 provides for a basket-like structure which is provided with a hook for hanging from the rim of the toilet bowl and is filled by the consumer with a viscous gel contained in a separate bottle which acts as a refill. The basket-like structure is provided with slits for the inflow of flushing water, which flows in an interspace along which it makes contact with the gel and removes a small amount thereof at each flush, carrying it into the labyrinth-like interspace from which it descends into the toilet bowl.

[0013] This system entails difficulty in providing in practice the gel-permeable wall, which should be constituted by very fine slits through which the gel can permeate and make contact with the flow of water that passes through the interspace.

[0014] The aim of the present invention is to eliminate the above-mentioned drawbacks, by providing an automatic dispenser of deodorant and detergent liquid for toilet bowls which allows to always have a constant dispensing of product which is removed by the flushing water without thereby producing undue releases.

[0015] Within the scope of this aim, a particular object of the present invention is to provide a device which allows high precision in dosage without however having to resort to a structure which is complicated or constituted by a large number of elements and components.

[0016] Another object of the present invention is to provide a device which can easily adapt to the various shapes of toilet bowls without requiring difficult operations for its application.

[0017] Another object of the present invention is to provide a device which by virtue of its particular constructive characteristics is capable of giving the greatest assurances of reliability and safety in use and is also competitive from a purely economical point of view.

[0018] This aim, these objects and others which will become apparent hereinafter are achieved by an automatic dispenser, particularly of deodorant and detergent liquid for toilet bowls, according to the invention, characterized in that it comprises a supporting element which can be applied to the rim of a toilet bowl, in a re-

gion affected by the flow of flushing water, and forms means for supporting a container of viscous liquid which is arranged so that its dispensing outlet is directed downward and is spaced from the inner bottom of said supporting element, a region being provided, at said inner bottom, for collecting water up to a level with a preset distance from a plug which is placed on said dispensing outlet and is provided with gauged holes for the release of said viscous liquid in controlled doses.

[0019] Further characteristics and advantages will become apparent from the description of a preferred but not exclusive embodiment of an automatic dispenser of deodorant and detergent liquid, illustrated only by way of non-limitative example in the accompanying drawings, wherein:

Figure 1 is a schematic exploded perspective view of the device according to the invention;

Figure 2 is a perspective view of the device in the assembled condition;

Figure 3 is a sectional view, taken along the plane III-III of Figure 2;

Figure 4 is a sectional view, taken along the plane IV-IV of Figure 3;

Figure 5 is an enlarged-scale view of the detail of the supporting element after flushing;

Figure 6 is an enlarged-scale view of the step for dispensing a controlled amount of product;

Figure 7 is a schematic plan view of the arrangement of the detergent liquid inside the support before flushing occurs;

Figure 8 is a sectional view, taken along the plane VIII-VIII of Figure 7;

Figure 9 is a schematic sectional view of the device according to the invention, applied to a bowl.

[0020] With reference to the above figures, the automatic dispenser particularly for deodorant and detergent liquid for toilet bowls, according to the invention, generally designated by the reference numeral 1, comprises a supporting element 2 which comprises a cradle-like body 3 which is shaped like a cylindrical portion and is open in an upward region.

[0021] The cradle-like element 3 forms a front wall 3a and a rear wall 3b which has, in its central part, a recess 4 for the detachable seating of a peduncle 5 which belongs to the hanging element, generally designated by the reference numeral 6.

[0022] The peduncle 5 can oscillate with respect to the cradle-like element 3 and is provided with a cross-member 10 which fits into an opening 11 of the wall 3b in order to stabilize the coupling and is arranged in a recess 20a of the container 20.

[0023] The peduncle 5 is connected to a connecting cross-member 12 which lies substantially at right angles to the peduncle and can be superimposed on the bottom of the container 20 of viscous liquid, which is applied to the support so that the dispensing outlet faces down-

ward.

[0024] The container 20 forms at its base, which is arranged upward, a recessed seat 21 in which a protrusion 22 of the cross-member 12 fits with a snap action in order to fix the container with respect to the support.

[0025] The hanging element is connected to the cross-member 5 and is substantially provided by means of a curled element 23 which overlaps the rim 24 of a toilet bowl 25, so that the supporting element is arranged at the toilet bowl 25 below the flushing water dispensing ports 26, so that the supporting element is struck by the flow of flushing water.

[0026] The container 20 is applied to the cradle 3 of the supporting element 2 so that the dispensing outlet, designated by the reference numeral 30, remains spaced with respect to the inner bottom of the cradle.

[0027] At the outlet 30 there is provided a closure plug 31 having gauged circular holes 32, as will become apparent hereinafter.

[0028] The container is supported by supporting means constituted by rests 40 which protrude from the inner bottom of the cradle 3 and support the container 20.

[0029] The cradle 3 is shaped so as to form, below the dispensing outlet 30, a water collection region, designated by the reference numeral 50, which in practice forms a small basin in which the flushing water and the detergent liquid collect.

[0030] It is important that the level of the liquid remains at a preset distance from the plug 31, so as to have a dispensing of the detergent liquid in controlled doses.

[0031] In order to maintain the level, overflow holes are provided in the cradle 3 at the bottom; said holes have a radial arrangement produced by the fact that the cradle-like element, as shown in Figure 9, is usually inclined by a few degrees with respect to the vertical with a front-to-back inclination, i.e., so that the rear part directed toward the peduncle 5 is at a lower level than the front part.

[0032] For this purpose, the overflow holes have a radial arrangement and dimensions which vary according to their distance from the rim of the basin that is formed and according to the type of material used, i.e., hydrophilic plastic materials or hydrophobic plastic materials such as resins or polypropylene.

[0033] With reference to Figure 7, the holes provided have a diameter between 0.5 and 0.7 millimeters if hydrophilic plastic materials are used for the supporting element and between 1.2 and 3.5 millimeters if hydrophobic plastic materials are used.

[0034] Merely by way of example, it is noted that when using polypropylene, the internal holes 51 provided preferably have a diameter of 1.3 millimeters on the inner part and 1.2 millimeters on the outer part. Central inner holes 52 are also provided which have a diameter of preferably 3.5 millimeters, as well as median holes 53 which have a diameter of 1.7 millimeters, and external

holes 54 which have a diameter of preferably 2.5 millimeters.

[0035] In practical execution, it has been observed that the plug 31 must have a distance between 0.5 and 4.5 millimeters from the level of the water that forms inside the basin, owing to the fact that the distance is a function of the amount of viscous product that is dispensed at each flush.

[0036] In order to achieve dispensing by controlled doses, after connecting the container to the support, the viscous liquid is pushed outward by its own weight, while the viscous force and the suction generated inside the container retain it, together with the counterthrust of the dispensed product that settles on the bottom of the cradle, so that after a preset dispensing of the product, which is a function of the distance of the plug 31 from the bottom, of the diameter of the holes 32 and of the viscosity of the product, the outflow of the product stops.

[0037] During flushing, the stream of water strikes the supporting element, generating a turbulent motion in the region between the cradle and the mouth of the container, so that the deposited product is carried into the bowl and a constant amount of air enters through the holes of the plug in the bottle.

[0038] The inflow of air into the bottle restores the internal pressure, causing a dose of product to flow out and settle on the support; the cycle can thus resume.

[0039] After each flush, the water that remains in the support flows out through the holes located in said support until it reaches a level whose distance from the plug varies between 0.5 and 4.5 millimeters.

[0040] The amount of water that remains inside the support also contributes in practice to stop the flow of the product due to buoyancy.

[0041] The diameter of the holes is important in evaluating the dispensed quantity because by increasing the diameter of the holes the amount of air that enters the bottle and therefore the amount of product that descends from it increase at each flush.

[0042] Moreover, the number and position of the holes provided in the support allows to determine the distance of the level of water that forms in the basin or collection region and accordingly to determine its distance from the dispensing outlet.

[0043] By adjusting the distribution of said holes it is possible to control the volume and therefore the level of the water that remains on the support after flushing.

[0044] Moreover, the arrangement of the holes must be such that regardless of the position of the frame in the toilet bowl, the holes of the plug are covered by the water remained in the support after flushing; finally, the diameter must be such as to allow the water to flow out after flushing but not allow, in static conditions, the outflow of the mixture of water and product that is present on the support.

[0045] For this purpose it is possible to provide, between the various groups of holes, grilles or ridges for containment which are designated by the reference nu-

meral 60 and are arranged on the inner bottom of the supporting element so as to control the level of the water collection basin regardless of any inclination of the support.

5 **[0046]** A very important element is further constituted by the viscosity of the product, since if the diameter of the holes provided in the plug, the distance between the plug and the support and the position of the holes in the support are equal, the amount of dispensed product de-
10 creases as the viscosity increases.

[0047] Experimental tests have shown that it is ideal to use, on the plug, holes which have a diameter of 2.5-3 millimeters and to use a product which has a viscosity between 1800 and 3400 cps, also according to the type
15 of material used for the supporting element.

[0048] In practical operation, therefore, at each flush the flushing water that flows through the support strikes the collection region, in which the detergent product is present, possibly mixed with the remaining water, and
20 conveys it into the toilet bowl.

[0049] In these conditions, a preset amount of air enters the container, so that a dispensing of viscous product occurs which in practice forms an outflow cone which settles on the bottom of the cradle-like element until it
25 stops further dispensing; automatic dosage of the product is therefore produced.

[0050] Only removal by means of the flow of the flushing water allows more product to flow out, depositing on the bottom.

30 **[0051]** From the above description it is thus evident that the invention achieves the intended aim and objects, and the fact is stressed in particular that a device is provided in which dosage of the product occurs uniformly and so as to allow an effectiveness which re-
35 mains constant throughout the period of use of the product.

[0052] The invention thus conceived is susceptible of numerous modifications and variations, all of which are within the scope of the inventive concept.

40 **[0053]** All the details may further be replaced with other technically equivalent elements.

[0054] In practice, the materials employed, so long as they are compatible with the specific use, as well as the contingent shapes and dimensions, may be any accord-
45 ing to requirements.

[0055] Where technical features mentioned in any claim are followed by reference signs, those reference signs have been included for the sole purpose of increasing the intelligibility of the claims and accordingly
50 such reference signs do not have any limiting effect on the interpretation of each element identified by way of example by such reference signs.

55 Claims

1. An automatic dispenser, particularly of deodorant and detergent liquid for toilet bowls, characterized

- in that it comprises a supporting element (2) which can be applied to the rim of a toilet bowl (25), in a region affected by the flow of flushing water, and forms means (40) for supporting a container (20) of viscous liquid which is arranged so that its dispensing outlet (30) is directed downward and is spaced from the inner bottom of said supporting element (2), a region being provided, at said inner bottom, for collecting water up to a level with a preset distance from a plug (31) which is placed on said dispensing outlet (30) and is provided with gauged holes (32) for the release of said viscous liquid in controlled doses.
2. The dispenser according to claim 1, characterized in that said supporting element (2) comprises a cradle-like body (3) which is shaped like a cylindrical portion and is connected to a peduncle (5) which is arranged at the end of a suspension element (6).
 3. The dispenser according to the preceding claims, characterized in that said cradle-like element (3) forms a front wall (3a) and a rear wall (3b) which has, in its central portion, a recess (4) for detachably accommodating said peduncle (5).
 4. The dispenser according to one or more of the preceding claims, characterized in that said peduncle (5) can oscillate with respect to said cradle-like element (3) and has a cross-member (10) which is adapted to fit and lock in an opening (11) formed in said recess (4) and is accommodated at a recess (20a) formed by said container (20).
 5. The dispenser according to one or more of the preceding claims, characterized in that said peduncle (5) is connected to said suspension element (6) by means of a connecting cross-member (12) which can be superimposed on said container (20).
 6. The dispenser according to one or more of the preceding claims, characterized in that said container (20) forms, at its bottom, a recessed seat (21) in which a protrusion (22) can be inserted by snap action, said protrusion being formed by said connecting cross-member (12) in order to fix said container (20).
 7. The dispenser according to one or more of the preceding claims, characterized in that it comprises, on said cradle (3), a plurality of overflow holes (51, 52, 53, 54) for determining the level of flushing water that remains in said water collection region.
 8. The dispenser according to one or more of the preceding claims, characterized in that said overflow holes (51, 52, 53, 54) are arranged radially and have a diameter which increases with their distance from said collection region.
 9. The dispenser according to one or more of the preceding claims, characterized in that said overflow holes (51, 52, 53, 54) have a diameter of 0.5 to 0.7 millimeters with said supporting element (2) made of hydrophilic plastic materials.
 10. The dispenser according to one or more of the preceding claims, characterized in that said overflow holes (51, 52, 53, 54) have a diameter of 1.2 to 3.5 millimeters with said supporting element made of hydrophobic plastic materials.
 11. The dispenser according to one or more of the preceding claims, characterized in that if said supporting element (2) is made of hydrophobic plastic materials, said overflow holes comprise inner holes (51) which lie closer to said collection region and whose diameter is 1.3 millimeters on the inner face of said bottom and 1.2 millimeters on the outer end.
 12. The dispenser according to one or more of the preceding claims, characterized in that it comprises, if said supporting element (2) is made of hydrophobic plastic materials, central inner holes (52) whose diameter is substantially 3.5 millimeters.
 13. The dispenser according to one or more of the preceding claims, characterized in that it comprises, if said supporting element (2) is made of hydrophobic plastic materials, median holes (53) with a diameter of 1.7 millimeters.
 14. The dispenser according to one or more of the preceding claims, characterized in that if said supporting element (2) is made of hydrophobic plastic materials, said overflow holes comprise outer holes (54) which have a diameter of substantially 2.5 millimeters.
 15. The dispenser according to one or more of the preceding claims, characterized in that said plug (31) has a distance of 0.5 to 4.5 millimeters from the level of the water that lies inside said collection region.
 16. The dispenser according to one or more of the preceding claims, characterized in that said viscous liquid has a viscosity between 1800 and 3400 cps.
 17. The dispenser according to one or more of the preceding claims, characterized in that said gauged holes (32) of said plug (31) have a diameter of substantially 2.5-3 millimeters.
 18. The dispenser according to one or more of the preceding claims, characterized in that it comprises, between said overflow holes (51, 52, 53, 54), con-

tainment grilles or ridges (60) in order to control the level of the water in said collection region.

5

10

15

20

25

30

35

40

45

50

55

6

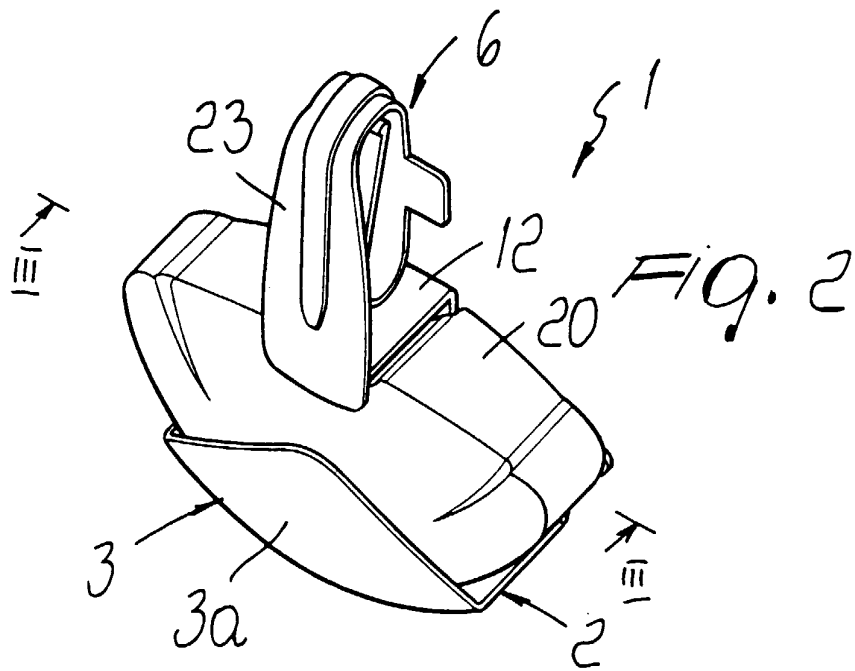
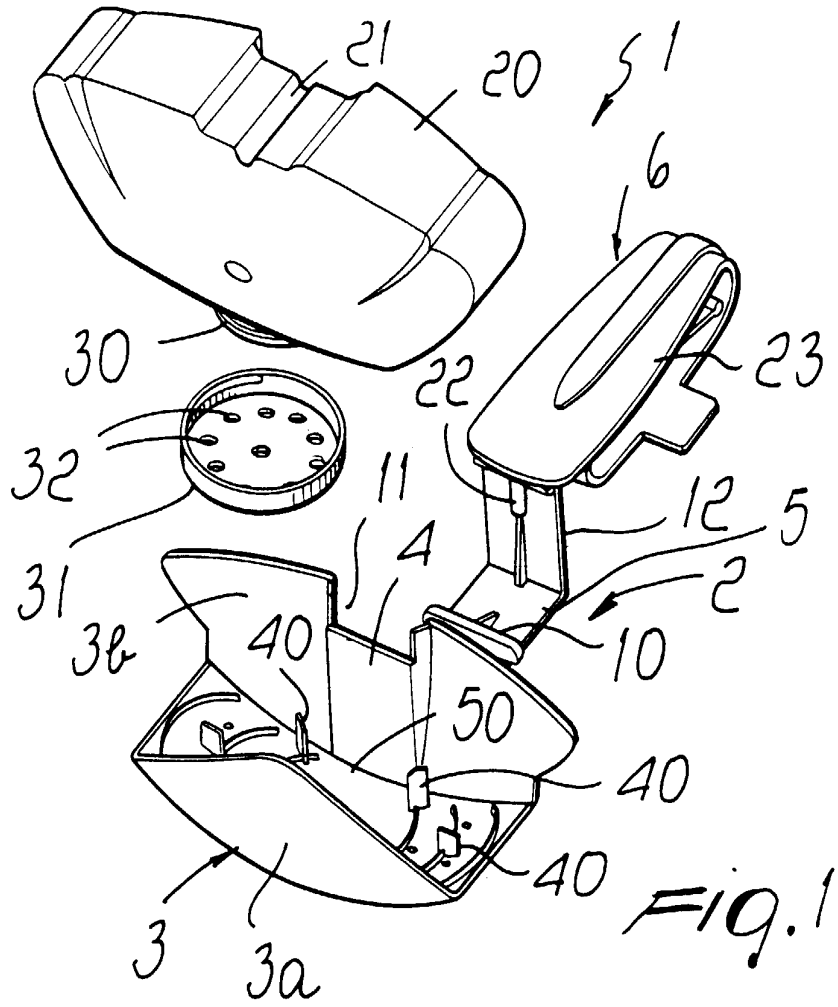

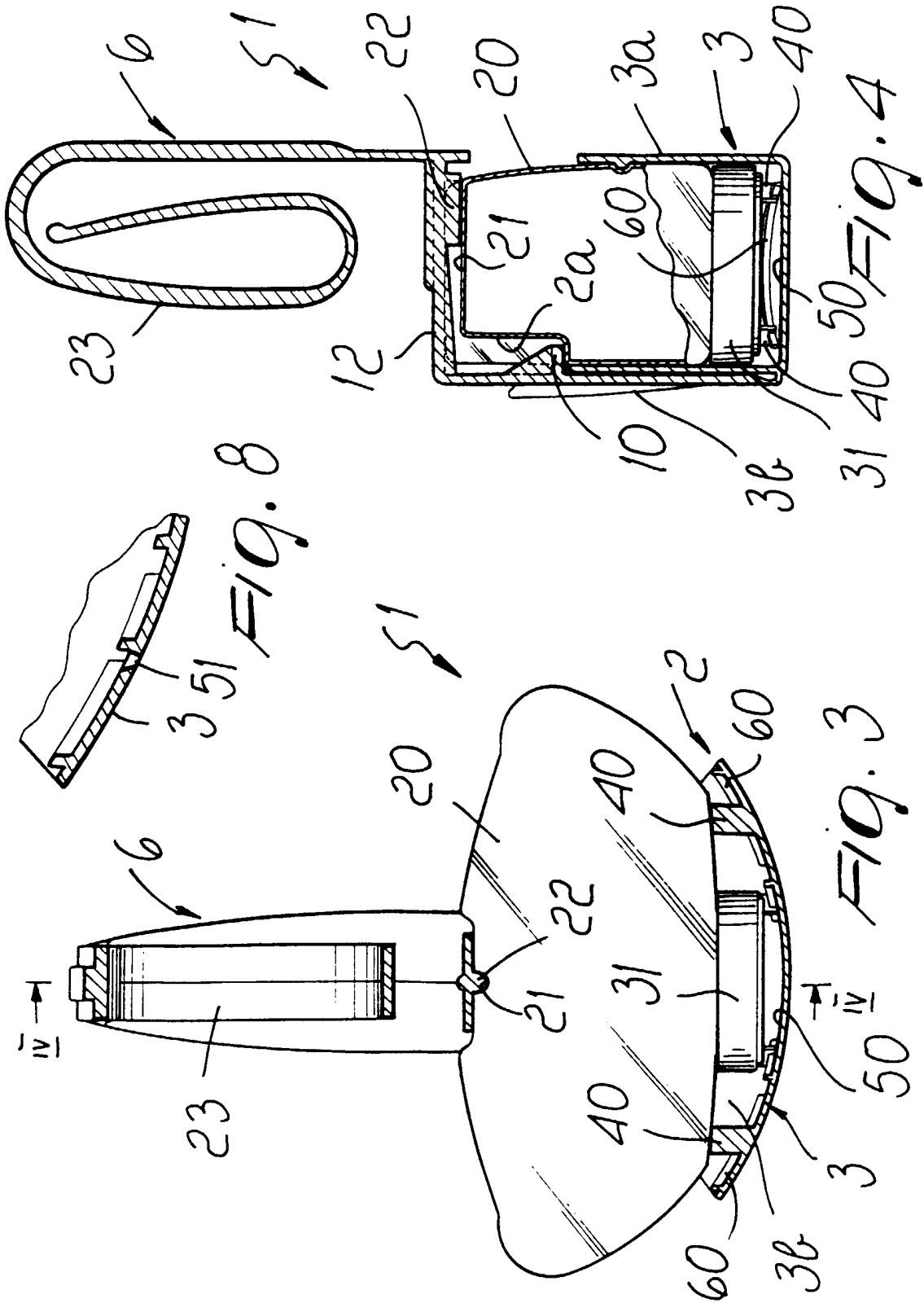

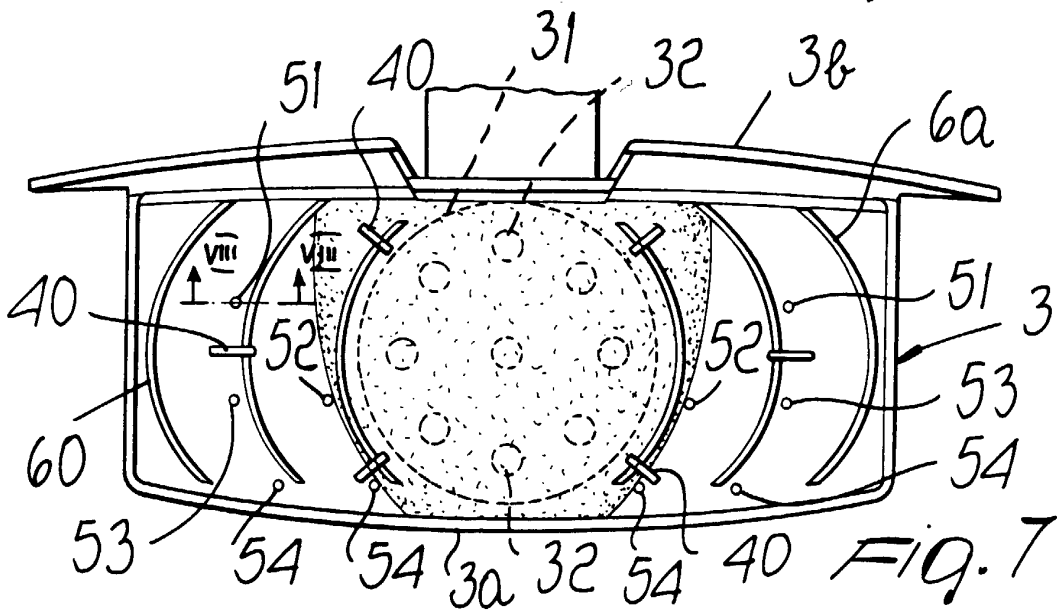
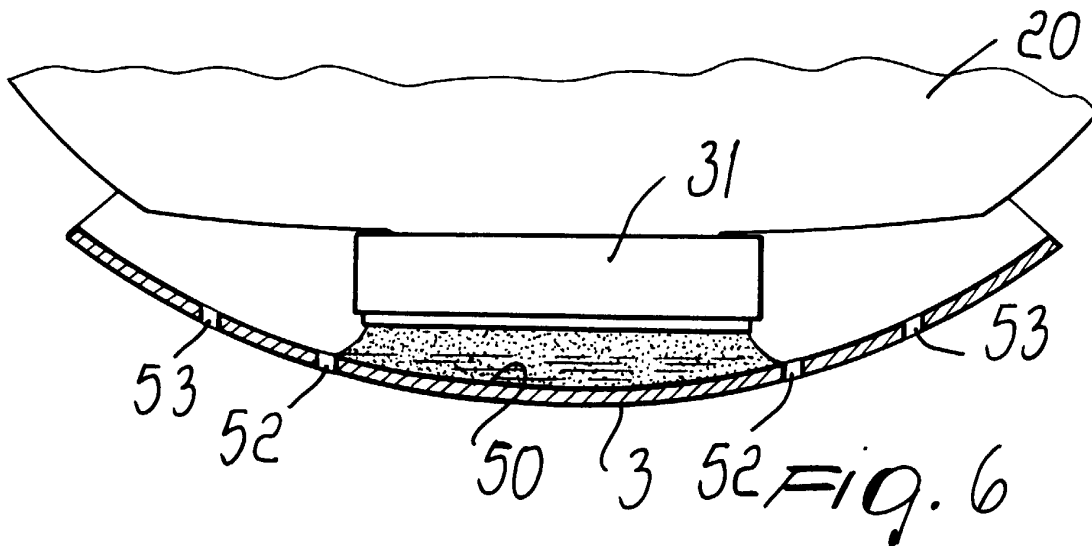
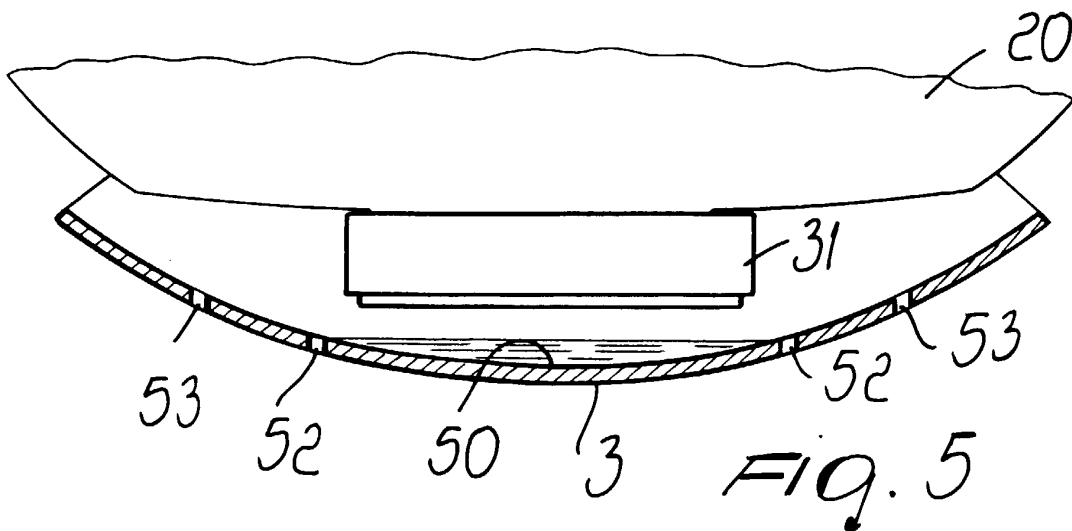

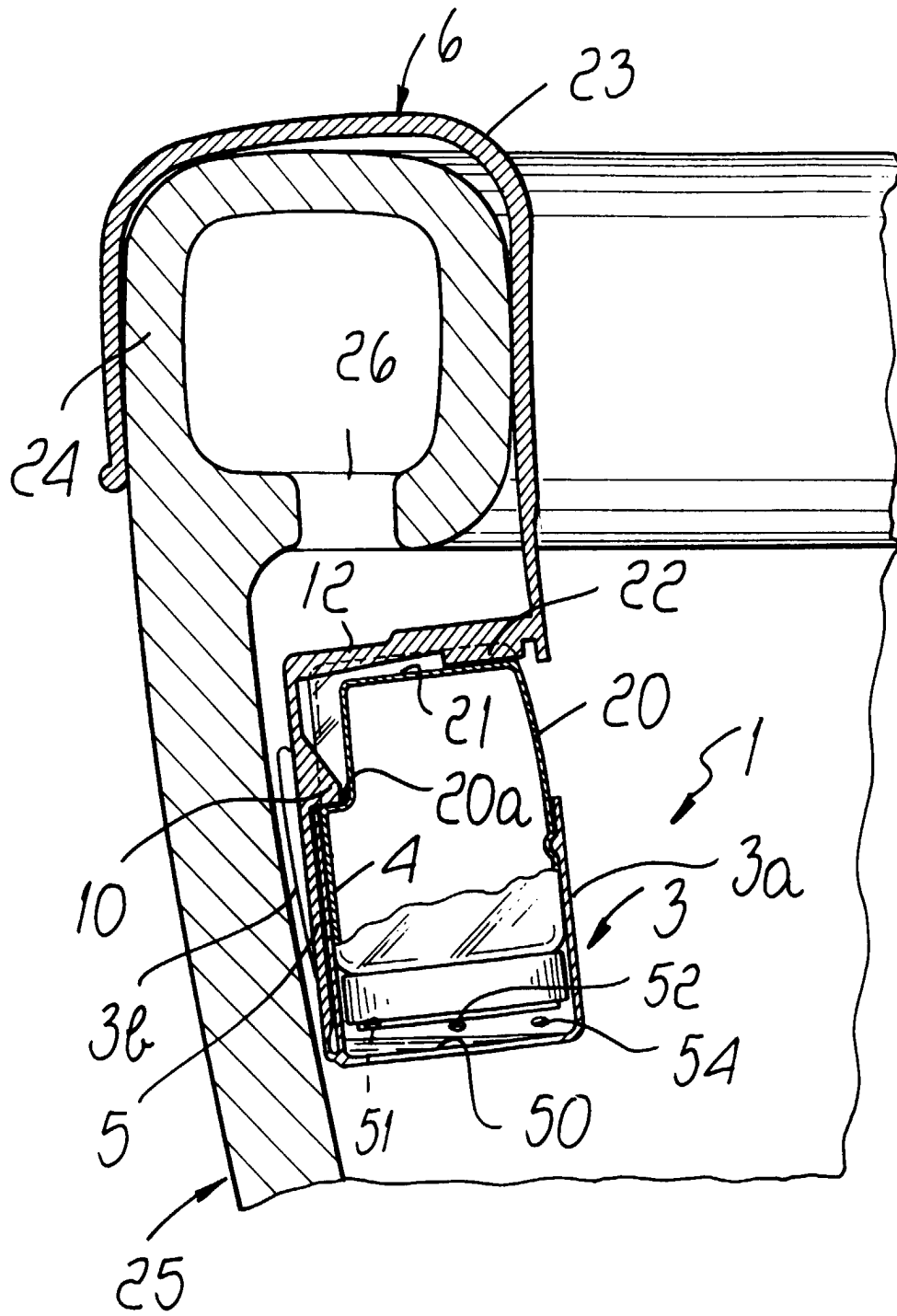

Fig. 9



European Patent Office

EUROPEAN SEARCH REPORT

Application Number
EP 99 83 0224

| DOCUMENTS CONSIDERED TO BE RELEVANT | | | |
|--|---|---|-----------------------------------|
| Category | Citation of document with indication, where appropriate, of relevant passages | Relevant to claim | CLASSIFICATION OF THE APPLICATION |
| A,D | EP 0 538 957 A (LEE DE NV SARA) 28 April 1993 (1993-04-28) * column 3, line 29 - column 4, line 1 * * column 2, line 30 - line 57 * * figure 2 * --- | 1,7 | E03D9/03 |
| A | DE 11 90 888 B (TESCHNER WILHELM) 8 April 1965 (1965-04-08) * column 3, line 42 - column 4, line 32 * * figure 1 * --- | 1 | |
| A | US 2 687 916 A (REYNOLDS MARTIN M.) 31 August 1954 (1954-08-31) * column 6, line 17 - line 43 * * figures 2,5 * --- | 1 | |
| A | WO 92 20876 A (BROOKLINE ALPHA LIMITED) 26 November 1992 (1992-11-26) * page 5, line 23 - page 6, line 3 * * figures 1,3,4 * --- | 1,16 | |
| A | US 4 261 957 A (SCHIMANSKI GEORG) 14 April 1981 (1981-04-14) * column 4, line 24 - line 37 * * figure 9 * ----- | 4-6 | TECHNICAL FIELDS SEARCHED E03D |
| The present search report has been drawn up for all claims | | | |
| Place of search THE HAGUE | | Date of completion of the search 14 September 1999 | Examiner Urbahn, S |
| CATEGORY OF CITED DOCUMENTS X : particularly relevant if taken alone Y : particularly relevant if combined with another document of the same category A : technological background O : non-written disclosure P : intermediate document | | T : theory or principle underlying the invention E : earlier patent document, but published on, or after the filing date D : document cited in the application L : document cited for other reasons & : member of the same patent family, corresponding document | |

EPO FORM 1503 03/82 (P04C01)

ANNEX TO THE EUROPEAN SEARCH REPORT
ON EUROPEAN PATENT APPLICATION NO.

EP 99 83 0224

This annex lists the patent family members relating to the patent documents cited in the above-mentioned European search report. The members are as contained in the European Patent Office EDP file on
The European Patent Office is in no way liable for these particulars which are merely given for the purpose of information.

14-09-1999

| Patent document cited in search report | Publication date | Patent family member(s) | Publication date |
|--|------------------|-------------------------|------------------|
| EP 0538957 A | 28-04-1993 | NL 9101759 A | 17-05-1993 |
| | | AU 656236 B | 27-01-1995 |
| | | AU 2718892 A | 29-04-1993 |
| | | CN 1074004 A | 07-07-1993 |
| | | DE 69208806 D | 11-04-1996 |
| | | DE 69208806 T | 25-07-1996 |
| | | DK 538957 T | 01-04-1996 |
| | | ES 2087436 T | 16-07-1996 |
| | | MW 5692 A | 13-04-1994 |
| | | NZ 244857 A | 26-10-1995 |
| | | ZA 9208168 A | 04-05-1993 |
| DE 1190888 B | NONE | | |
| US 2687916 A | 31-08-1954 | NONE | |
| WO 9220876 A | 26-11-1992 | AU 1789792 A | 30-12-1992 |
| | | CA 2103249 A | 18-11-1992 |
| | | EP 0584172 A | 02-03-1994 |
| | | FI 935079 A | 18-11-1993 |
| | | JP 7503767 T | 20-04-1995 |
| | | NO 934143 A | 16-11-1993 |
| US 4261957 A | 14-04-1981 | NONE | |