

(19) (KR)  
(12) (B1)

(51) 。 Int. Cl. 7 (45) 2003 03 04  
H04J 13/00 (11) 10 - 0374336  
H04Q 7/30 (24) 2003 02 19

(21) 10 - 2000 - 0019301 (65) 2000 - 0071672  
(22) 2000 04 12 (43) 2000 11 25

(30) 1019990013610 1999 04 12 (KR)  
1019990019080 1999 05 26 (KR)  
1019990027355 1999 07 07 (KR)  
1019990027398 1999 07 08 (KR)

(73) 3 416

(72) 3 191 - 26

109 303

806 901

(74)  
:

(54)

(CDMA)

(Dedicated Channel)

( ) (DPDCH) ( ) 가 , DPDCH  
가 ( )  
( ) (Gated transmission) DPCCH  
(PCG)/ ( / )  
( )  
(TFCI), (TPC),  
(TFCI), (TPC),

가  
 DPCCH  
 TFCI, TPC가  
 (short data)가  
 가,  
 (FBI)가  
 ( )  
 DPCCH  
 가  
 TFCI TPC  
 , n+1  
 DPDCH  
 가

10a

(Gated transmission), (Dedicated Physical Control Channel), , ,

1a

1b DCH/DCH

2a DPDCH DPCCH

2b DPDCH DPCCH

3a

3b

4a

4b

5a DPDCH

DPCCH

DPCCH

5b DPDCH

DPCCH

DPCCH

6a DPCCH

6b DPCCH

7a DPCCH

DPDCH 가

7b	DPCCH	DPDCH	가
8a		DPDCH	
8b		DPDCH	
8c		DPDCH	
8d		DPDCH	
9a	( DPCCH )	DPDCH	
9b	( DPCCH )	DPDCH	
10a			
10b			
11a		DPCCH	
11b		DPCCH	
11c		DPCCH	
11d		DPCCH	
11e		DPCCH	
12a		DPCCH	
12b		DPCCH	
12c		DPCCH	
12d		DPCCH	
12e		DPCCH	

(Code Division Multiple Access : CDMA .)  
(Dedicated Channel)

CDMA  
가 IMT - 2000  
가 가 IMT - 2000

가 가

가

(Traffic Channel)

가

UTRA(UMTS(Universal Mobile Telecommunications System) Terrestrial R

adio Access)

가 가  
3GPP RAN TS S2 (S2.03,99.04)

1a (Cell Connected State) (State Transition)

1a PCH(Paging Channel) , RACH(Random Access Channel)/DSCH(Downlink Shared Channel) , RACH(Random Access Channel)/FACH(Forward link Access Channel) , DCH(Dedicated Channel)/DCH, DCH/DCH+DSCH, DCH/DSCH+DSCH Ctrl(Control Channel)

1b DCH/DCH, DCH/DCH+DSCH, DCH/DSCH+DSCH Ctrl (User data active substate) (Control only substate)  
가 ( : DCH/DCH )

CDMA

가

가

가

(Dedicated Data Channel)

가

(Dedicated Control Channel)

(Control Only substate) 가

( ) ( )

(Dedicated Physical Control CHannel,  
(Dedicated Physical Data CHannel,

DPCCH ) ,  
DPDCH ) DPDCH , DPCCH  
(Transport Format Combination Indicator, TFCI ),  
( ) (Transmit Power Control, TPC ), 가  
PDCH DPCCH 가 ( ) , D

가 10 msec , (Power Control Group)  
가 0.625 msec  
16 가 10 msec , 15 가  
0.667 msec (0.625ms 0.667 msec)  
(0.625ms 0.667 msec) 가 가  
(Pilot), (TFCI), (TPC)

2a DPDCH DPCCH가 (Slot) 2a DPDC  
H 1(Data1) 2(Data2) ,  
1 2 1 DPDCH/DPCCH  
가 TFCI, TPC, Pilot

DPDCH DPCCH DPDCH DPCCH

2b DPDCH DPCCH가 2b TFC  
I, FBI, TPC, Pilot FBI(FeedBack Information) (transm  
it diversity) 2  
3 DPDCH DPCCH

[ 1 ]

Channel Bit Rate(kbps)	Channel Symbol Rate(kps)	SF	Bits/Frame			Bits/Slot	DPDCH Bits/Slot		DPCCH Bits/Slot		
			DPDCH	DPCCH	TOT		Ndata1	Ndata2	N <sub>TF</sub> <sub>CI</sub>	N <sub>TP</sub> <sub>C</sub>	Npilot
16	8	512	64	96	160	10	2	2	0	2	4
16	8	512	32	128	160	10	0	2	2	2	4
32	16	256	160	160	320	20	2	8	0	2	8
32	16	256	128	192	320	20	0	8	2	2	8
64	32	128	480	160	640	40	6	24	0	2	8
64	32	128	448	192	640	40	4	24	2	2	8
128	64	64	1120	160	1280	80	14	56	0	2	8
128	64	64	992	288	1280	80	6	56	8	2	8
256	128	32	2400	160	2560	160	30	120	0	2	8
256	128	32	2272	288	2560	160	22	120	8	2	8
512	256	16	4832	288	5120	320	62	240	0	2	16
512	256	16	4704	416	5120	320	54	240	8	2	16
1024	512	8	9952	288	10240	640	126	496	0	2	16
1024	512	8	9824	416	10240	640	118	496	8	2	16
2048	1024	4	20192	288	20480	1280	254	1008	0	2	16
2048	1024	4	20064	416	20480	1280	246	1008	8	2	16

[ 2 ]      DPDCH

Channel Bit Rate(kbps)	Channel Symbol Rate(kps)	SF	Bits/Frame	Bits/Slot	Ndata
16	16	256	160	10	10
32	32	128	320	20	20
64	64	64	640	40	40
128	128	32	1280	80	80
256	256	16	2560	160	160
512	512	8	5120	320	320
1024	1024	4	10240	640	640

[ 3 ]

Channel Bit Rate(kbps)	Channel Symbol Rate(ksps)	SF	Bits/Frame	Bits/Slo t	Npilot	N <sub>TPC</sub>	N <sub>TFC</sub> l	N <sub>FBI</sub>
16	16	256	160	10	6	2	2	0
16	16	256	160	10	8	2	0	0
16	16	256	160	10	5	2	2	1
16	16	256	160	10	7	2	0	1
16	16	256	160	10	6	2	0	2
16	16	256	160	10	5	1	2	2

1, 2 3  
4 DPDCH가 (Spreading Factor) , DPDCH가 , 2, 3, SF

( ) 3a 3b  
DPDCH가

3a

3a , 111, 121, 131, 132  
G<sub>1</sub>, G<sub>2</sub>, G<sub>3</sub>, G<sub>4</sub> 가 DPCCH DPDCH 1,2, ( ) 112 D

PCCH DPDCH<sub>1</sub> ( ) 2a 가 1

S/P 113 112 I Q 2 S/P 133

3 S/P 134 DPDCH<sub>2</sub> DPDCH<sub>3</sub> I Q

114, 122, 135, 136, 137, 138  
(Channelisation code) C<sub>ch1</sub>, C<sub>ch2</sub>, C<sub>ch3</sub> 가

114, 122, 135, 136, 137, 138 I Q 1

115 2 123 I 1 115 Q 2

123 124 90 116 1 115

124 I+jQ 117

PN (C<sub>scramb</sub>) , 118

I Q 118 I Q 119

125 가 119,125 120 126

(cos{2 f<sub>c</sub>t}, sin{2 f<sub>c</sub>t}) , 127

I Q

3b

3b , 211, 221, 223, 225 DPCCH DPDCH 1,2,  
 3 (Channelisation code) C<sub>ch1</sub>, C<sub>ch2</sub>, C<sub>ch3</sub>, C<sub>ch43</sub> 211, 221, 22  
 가 G<sub>1</sub>, G<sub>2</sub>, G<sub>3</sub>, G<sub>4</sub> G<sub>1</sub>, G  
 3, 225 212, 222, 224, 226 212, 222 1 213 I  
 2, G<sub>3</sub>, G<sub>4</sub> 가 227 Q 214 1 213 Q  
 2 227 228 90 215 PN  
 228 I+jQ 229 I Q 216 230  
 (C<sub>scramb</sub>) I Q 가 216,230 217 231  
 (cos{2 f<sub>c</sub>t}, sin{2 f<sub>c</sub>t}) , 218  
 I Q

5a DPDCH ,  
 가 DPCCH DPCCH

5b DPDCH , 가  
 DPCCH DPCCH

5a 5b , DPDCH 가  
 DPCCH (Radio Resource Control Connection Released state)( 가 )  
 DPCCH 가 DPCCH 가

DPCCH 가

가  
 DPCCH

가

DPDCH 가  
 DPCCH

(DPCCH)



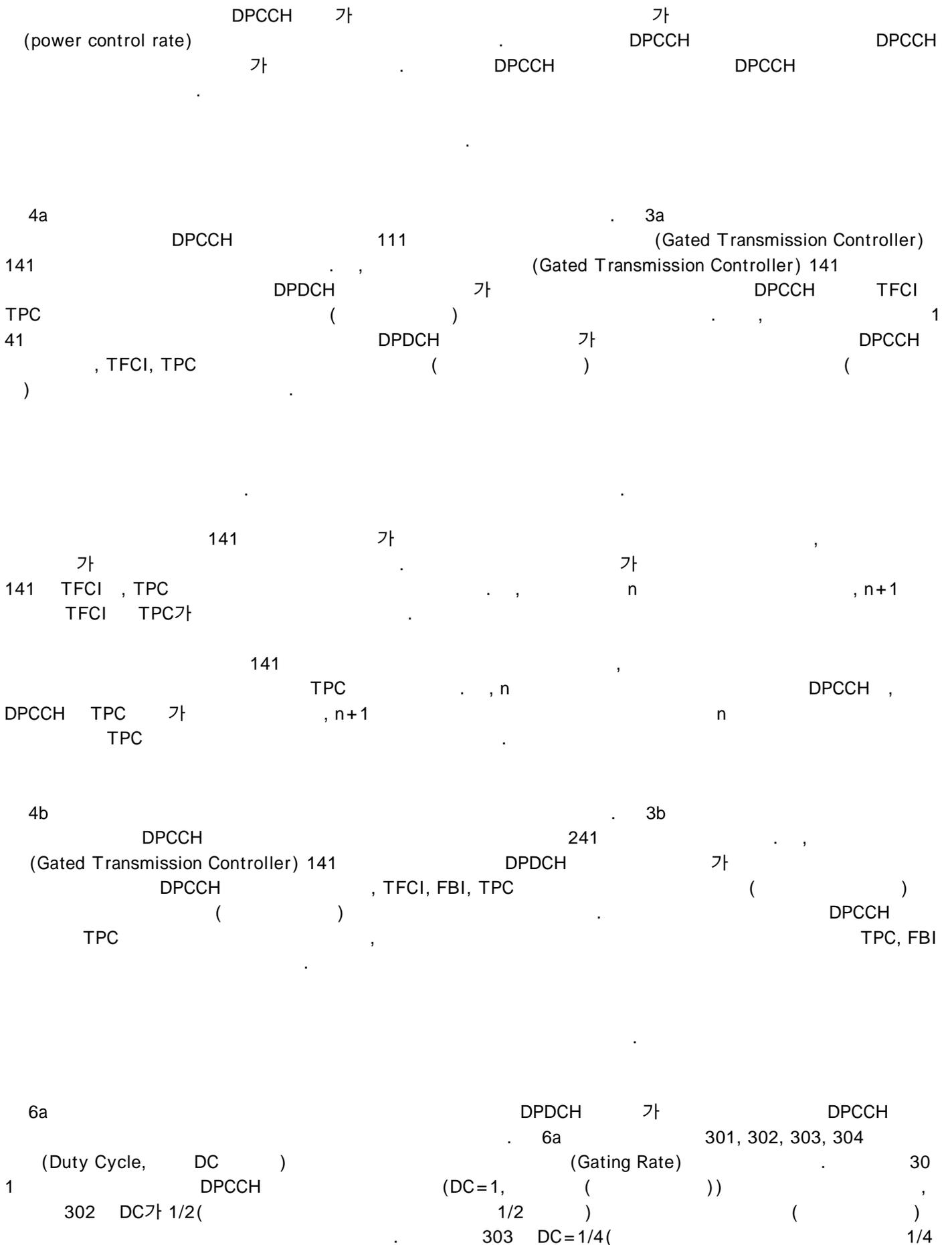

) (3, 7, 11, 15) )  
 304 DC=1/8( 1/8 )  
 (7, 15) ) 6a DC=  
 1/2, 1/4 241 DPCCH  
 DC , DC=1/2  
 , DC=1/2 (8, 15)  
 , DC=1/4 1/4 3/4 (12, 15)  
 ) , DC=1/8 1/8 7/8 (14, 15)  
 )

가  
 =1/1 DC=1/4 , DC=1/1 DC=1/8 DC=1/1 DC=1/2 , DC  
 DC=1/1 DC=1/2 , DC=1/2 DC=1/4 , DC=1/4 DC=1/8 DC

6b DPDCH 가 DPCCH  
 6b 305, 306, 307 DC  
 2 305 DC=1/2( 1/2 )  
 (2, 3, 6, 7, 10, 11, 14, 15)  
 306 DC=1/4( 1/4 ) 2  
 (6, 7, 14, 15)  
 307 DC=1/8( 1/8 ) 2  
 (14, 15) ) 6b DC=1/2, 1/4  
 241 DPCCH , DC=1/2 2  
 DC  
 4 ( : 2 5 )

가  
 DC=1/1(full rate) DC=1/2 , DC=  
 1/1 DC=1/4 , DC=1/1 DC=1/8  
 DC=1/1 DC=1/2 , DC=1/2 DC=1/4 , DC=1/4 DC=1/8  
 DC

7a 7b 6a 6b DPDCH 가 MAC(  
 Medium Access Control) DPDCH  
 DPCCH 7a 311 DPCCH ( ,  
 , DC=1/1) DPDCH 가 312 DPCCH  
 DC=1/2 DPDCH 가 313  
 DPCCH DC=1/4 DPDCH 가 3



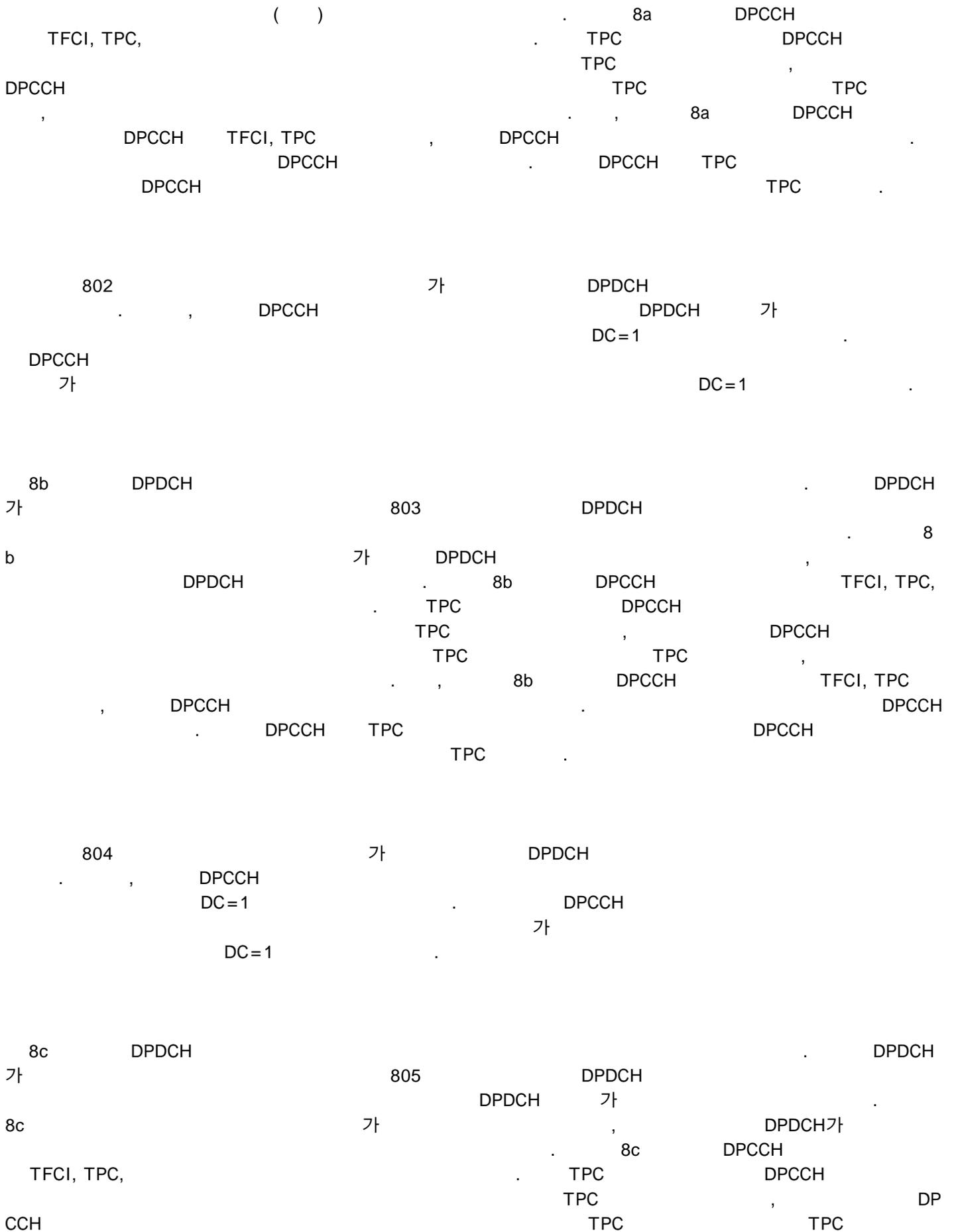

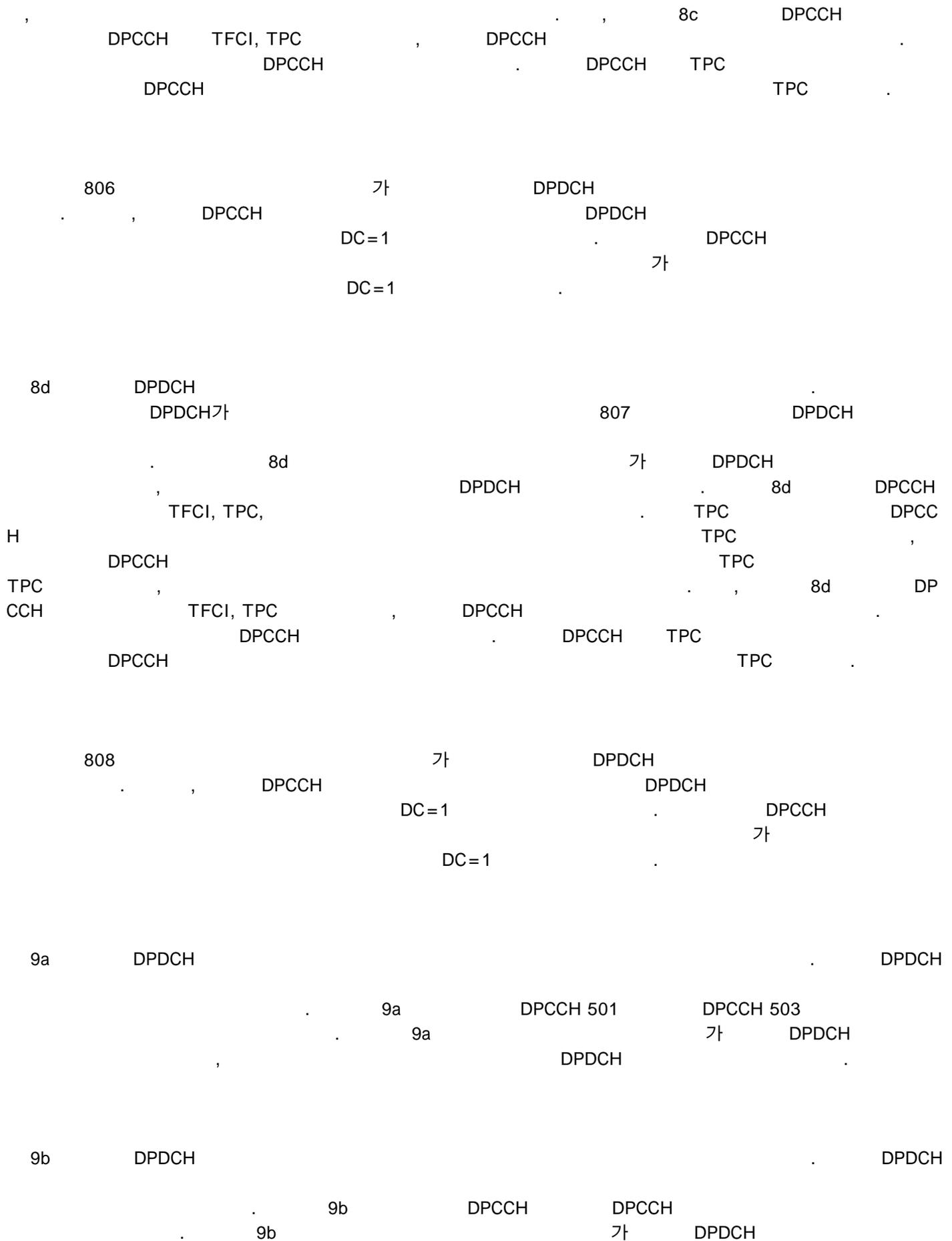

DPDCH

UTRA

250  
(Propagation delay)

30km  
(1 slot=0.625ms)

DPCCH 11a, 11b, 11c, 11d, 1

11e  
0a 10b

10a

DPCCH (Pilot), TFCI, TPC

(Gated Transmission Controller) 141

(Gated Transmission Controller) 141

DPDCH

가 ( (pilot) n+1 TFCI TPC 141 n (slot) 141 가

pilot TFCI

DPCCH ( ) 141 , TFCI, TPC DPDCH ( 가 )

10b

DPCCH Pilot, TFCI, FBI TPC

241

(Gated Transmission Controller) 241

DPDCH

가 ( )

DPCCH Pilot, TFCI, FBI TPC 241 가

pilot TFCI

(Gated Tran

DPCCH ( ) 241 , TFCI, FBI TPC DPDCH ( 가 )

11a 11e , 12a 12e 10a 10b  
 (Power Control Group) 16 가 10msec ,  
 가 0.625 msec  
 (Power Control Group) 15 , 12a 12e 가 10 msec ,  
 가 0.667 msec

11a DPCCH 11a  
 DPCCH 가  
 n n+1 TFCI, TPC DPCCH  
 , TFCI TPC , 1/2  
 0 1 TFCI, TPC가 (Downlink) DPCCH  
 1/4 2 TFCI, TPC가 (Downlink) DPCC  
 H 1/8 6 TFCI, TPC가 7 TFCI, TPC가  
 (Downlink) DPCCH TPC n+1  
 TPC n DPCCH

가 DPDCH  
 , n ) DPCCH TPC 10a DPCCH TPC가 , 15(16  
 n TPC , n+1  
 TPC

UTRA (offset) 250 DP  
 CCH , DPCCH  
 250 , 30km DPCCH

11b DPCCH 1  
 /2, 1/4, 1/8 (Downlink) DPCCH (Uplink) DPCC  
 H 가 1/2, 1/4, 1/8 'DL - UL timing'

11b , n n+1 TFCI, T  
 PC DPCCH , 1/2 0 ,  
 1 TFCI, TPC가 (Downlink) DPCCH 1/4  
 2 (Downlink) DPCCH (Downlink) DPCCH  
 1/8 6 TFCI, TPC가 7 TFCI, TPC가 (Downlink) DPCCH

15(16) (Downlink) DPCCH TPC (Uplink) DPCCH TPC가

11c DPCCH (Uplink) DPCCH (Downlink) DPCCH 1

/2, 1/4, 1/8

PC 11c n n+1 TFCI, T

DPCCH 1/2 1

2 TFCI, TPC가 (Downlink) DPCCH 1/4

2 3 TFCI, TPC가 (Downlink) DPCCH

1/8 6 7 TFCI, TPC가 (Downlink) DPCCH

11c DPCCH TPC가 1/2 15

15(16) (Downlink) DPCCH TPC (Uplink) DPCCH TPC가

11d DPCCH (Downlink) DPCCH (Uplink) DPCC 1

/2, 1/4, 1/8

H

PC 11d n n+1 TFCI, T

DPCCH 1/2 0

1 TFCI, TPC가 (Downlink) DPCCH 1/4

0 1 TFCI, TPC가 (Downlink) DPCCH

1/8 2 3 TFCI, TPC가 (Downlink) DPCCH

15(16) (Downlink) DPCCH TPC (Uplink) DPCCH TPC가

11e DPCCH (Uplink) DPCCH (Dow

1/2, 1/4, 1/8

nlink) DPCCH

11e n n+1 TFCI, TPC

DPCCH 1/2 1 2

TFCI, TPC가 (Downlink) DPCCH 1/4 2

3 TFCI, TPC가 (Downlink) DPCCH 1/8

6 , 7 TFCI, TPC가 (Downlink) DPCCH

15(16) ) (Downlink) DPCCH TPC (Uplink) DPCCH TPC가  
 11e DPCCH TPC가 1/2 15

12a DPCCH (Gating Rate) 1/3 , 12a 1  
 /3 5 가 n n+1  
 TFCI, TPC DPCCH TFCI TPC

12a < case 1 (Uplink) DPCCH (Downlink) DPCCH  
 1 2 TFCI, TPC가 (Downlink) DPCCH  
 , 4 5 TFCI, TPC가 (Downlink) DPCCH  
 , 7 8 TFCI, TPC가 (Downlink) DPCCH  
 , 10 11 TFCI, TPC가 (Downlink) DPCCH  
 , 13 14 TFCI, TPC가 (Downlink) DPCCH

< case 2 (Uplink) DPCCH (Downlink) DPCCH  
 0 1 TFCI, TPC가  
 (Downlink) DPCCH , 3 4 TFCI, TPC가  
 (Downlink) DPCCH , 6 7 TFCI, TPC가  
 (Downlink) DPCCH , 9 10 TFCI, TPC가  
 (Downlink) DPCCH , 12 13 TFCI, TPC가  
 (Downlink) DPCCH

< case 3 (Uplink) DPCCH (Downlink) DPCCH  
 1 2 TFCI, TPC가  
 (Downlink) DPCCH , 4 5 TFCI, TPC가  
 (Downlink) DPCCH , 7 8 TFCI, TPC가  
 (Downlink) DPCCH , 10 11 TFCI, TPC가  
 (Downlink) DPCCH , 13 14 TFCI, TPC가  
 (Downlink) DPCCH

< case 4	(Uplink) DPCCH		(Downlink) DPCCH	
		14	0	TFCI, TPC가
(Downlink) DPCCH	,	2	3	TFCI, TPC가
(Downlink) DPCCH	,	5	6	TFCI, TPC가
(Downlink) DPCCH	,	8	9	TFCI, TPC가
(Downlink) DPCCH	,	11	12	TFCI, TPC
가 (Downlink) DPCCH				

< case 5	(Uplink) DPCCH		(Downlink) DPCCH	
		0	1	TFCI, TPC가
(Downlink) DPCCH	,	3	4	TFCI, TPC가
(Downlink) DPCCH	,	6	7	TFCI, TPC가
(Downlink) DPCCH	,	9	10	TFCI, TPC가
(Downlink) DPCCH	,	12	13	TFCI, TPC가
(Downlink) DPCCH				



12b	,	3	4	TFCI, TPC가	(Dow
nlink) DPCCH	,	8	9	TFCI, TPC가	(Dow
nlink) DPCCH	,	13	14	TFCI, TPC가	(D
ownlink) DPCCH					

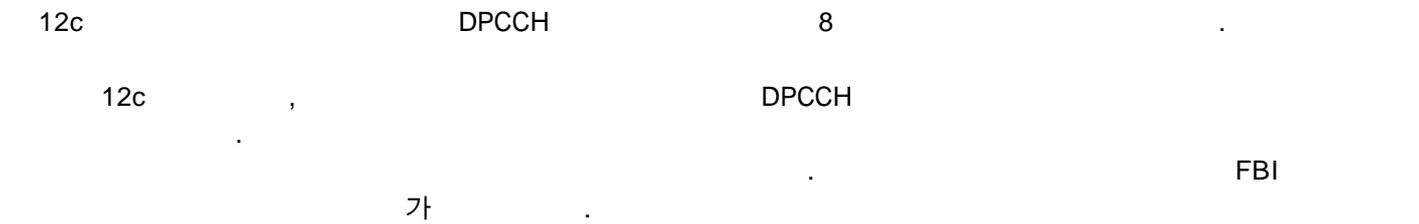

12d		DPCCH	9		
12d	,	가	(DPDCH transmission)		TFCI
	,	TPC	( )가		
TPC		TFCI	0 , 3 , 6 , 9 , 12		
, TFCI	TPC	1 , 4 , 7 , 10 , 13			



4.

2 , ,

5.

4 , , TFCI , TFCI ,

6.

4 n , , n+1 , TFCI TFCI ,

7.

2 ,

8.

1 2 , ;

1 ; 2 가 1 가

9.

8 , 1

10.

8 , 1

11.

9 , 1 , TFCI

12.

11 FCI , T

- 13.
  - 11 TFCI , n , n+1 .
- 14.
  - 10 , , (DPDCH) .
- 15.
  - 8 , 1 (DPCCH) .
- 16.
  - 8 , 2 (DPDCH) .
- 17.
  - (DPCCH) ,
  - 가 ,
  - 가 .
- 18.
  - 17 , 가 , , .
- 19.
  - 17 , .
- 20.
  - 19 , 2 , TFCI FBI .
- 21.
  - 20 , FBI , TFCI , .
- 22.

19 , (DPDCH)

23.

22 , 가 .

24.

, FBI (DPDCH) TFCI ,

(DPCCH) ;

DCH) ; (DP

;

가

가 .

25.

24 , .

26.

24 , .

27.

25 , , .

28.

27 , n ,

TFCI , FBI

29.

26 , , .

30.

1 가 (a) ,

(b) , 1 가

(c) , 1 1

2 가 (d) ,

(e) , 2 가

(f) , 2 2

31.

30 , 1 , 1 .

32.

30 , 1 .

33.

31 , 1 , 1 2

34.

33 , 1 n , 1  
2 .

35.

33 , 1 n , n+1  
1 2 .

36.

31 , 1

37.

30 , 2 , 2 .

38.

37 , 2

39.

37 , 2 , 1 , 2  
3 가

40.

37 , 2 , 1 , 2  
3

41.

38 , 2 가

42.

39 , 2 가  
2 3

43.

30 , 1 2

1a

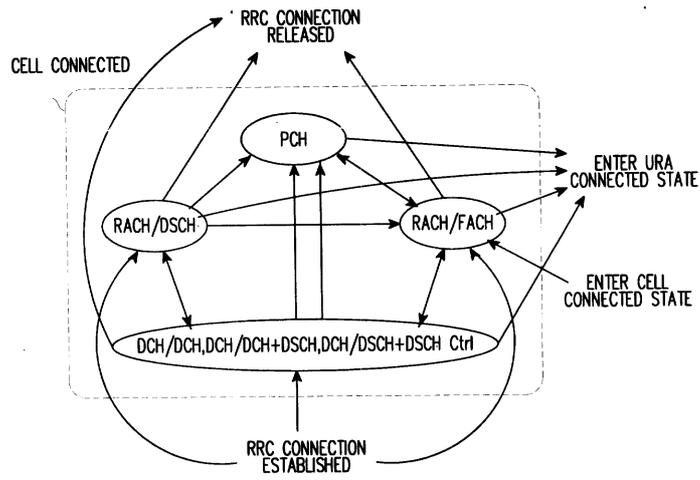

1b

DCH/DCH, DCH/DCH+DSCH, DCH/DSCH+DSCH Ctrl

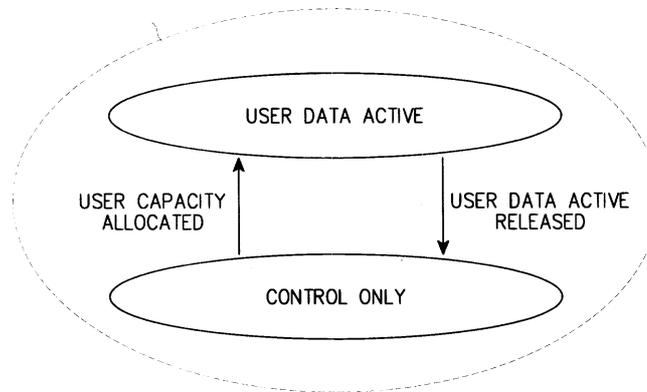

2a

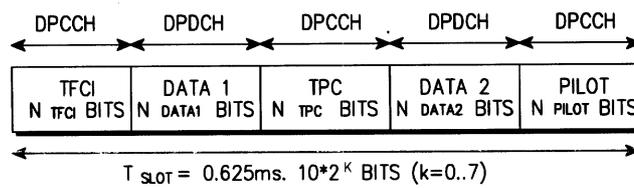

2b

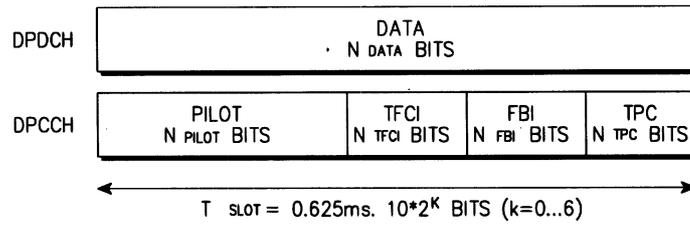

3a

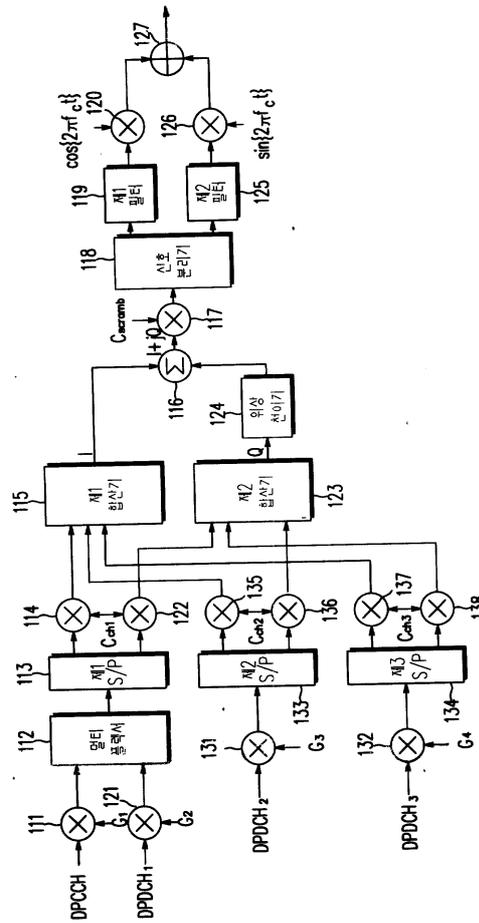

3b

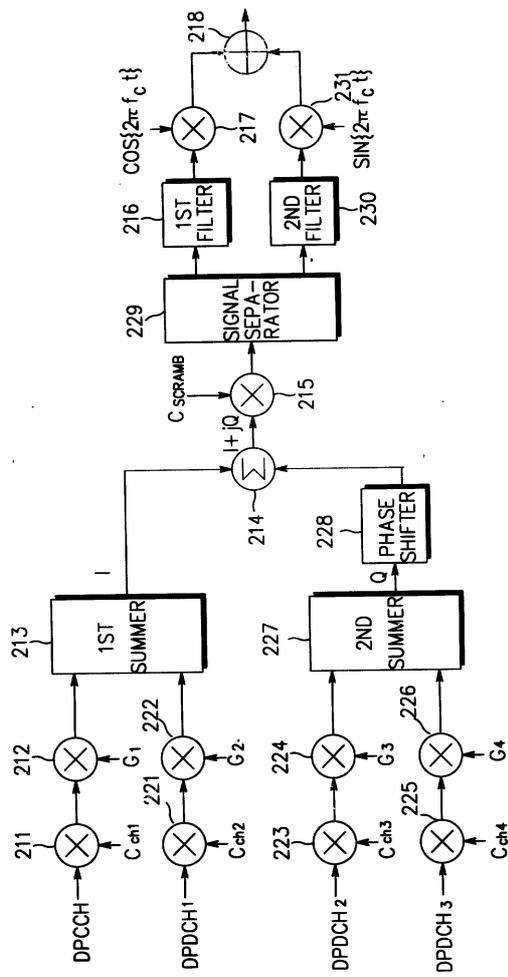

4a

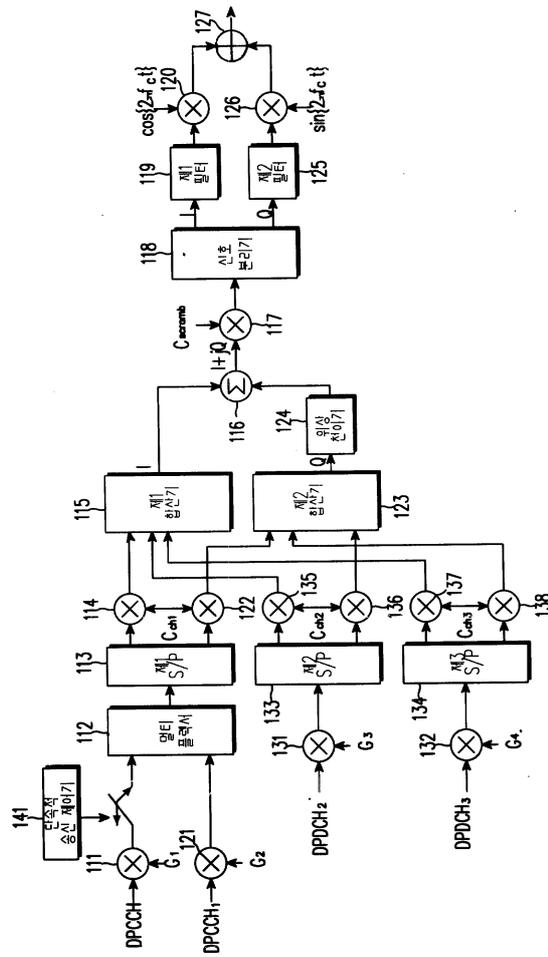

4b

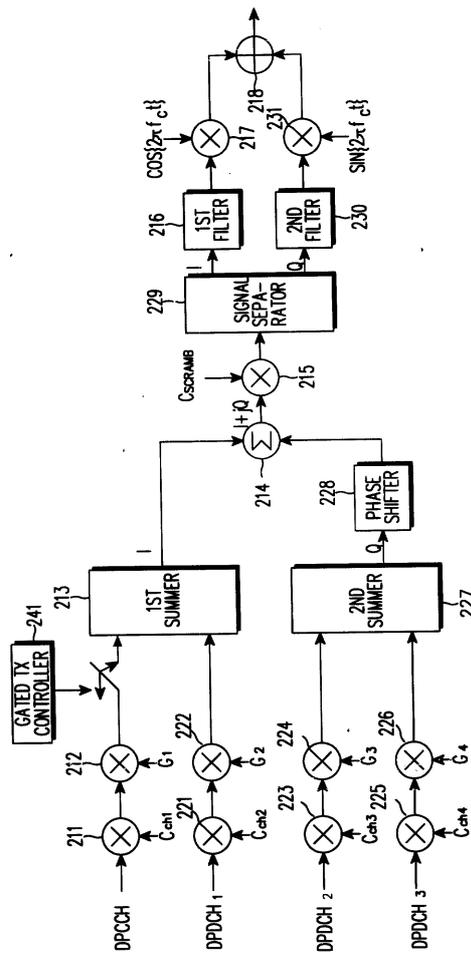

5a

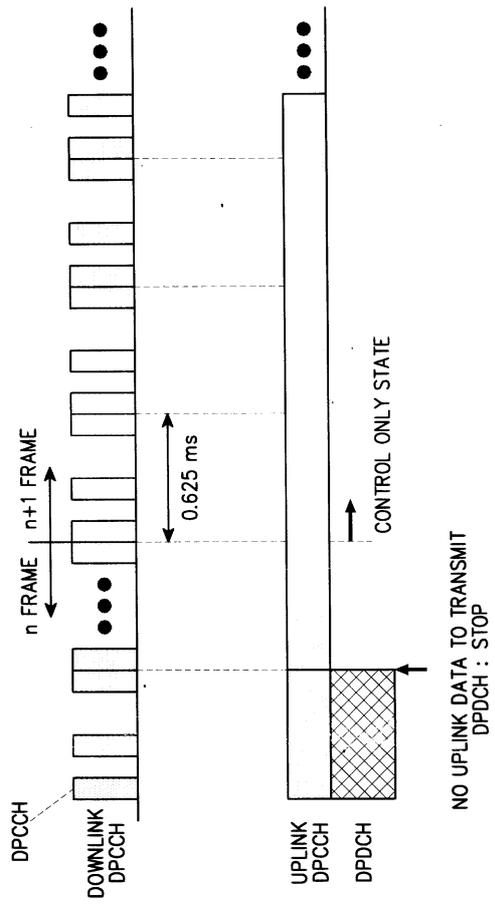

5b

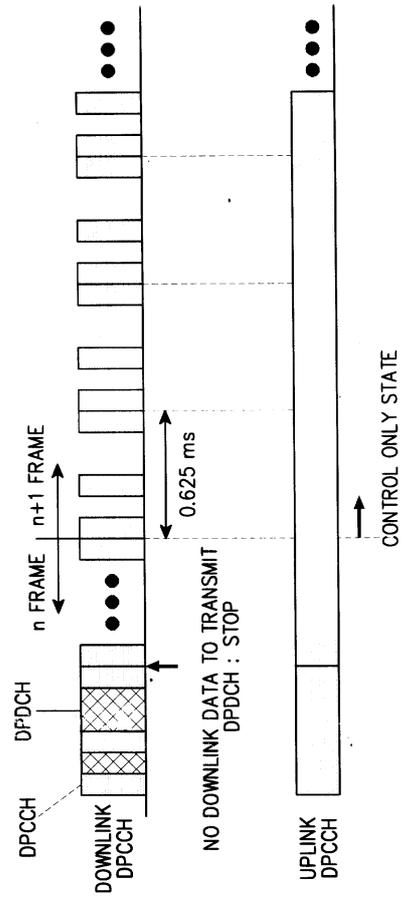

6a

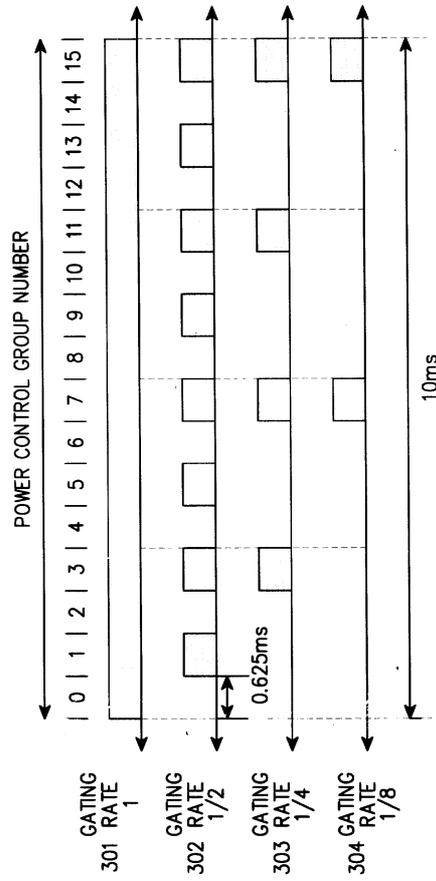

6b

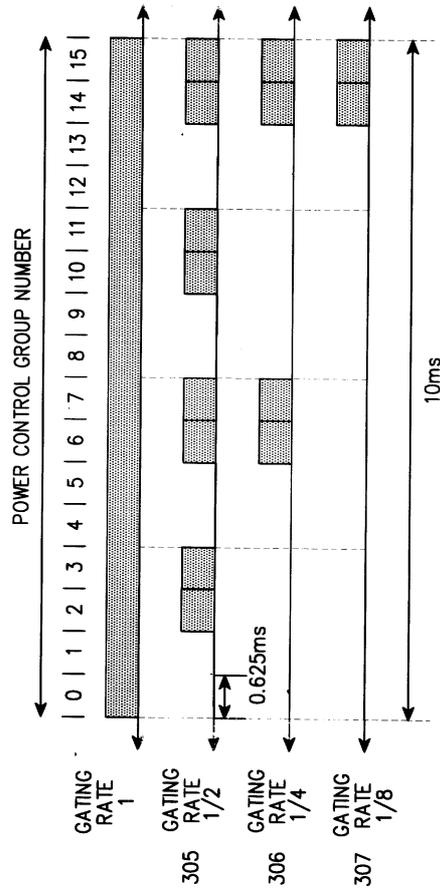

7a

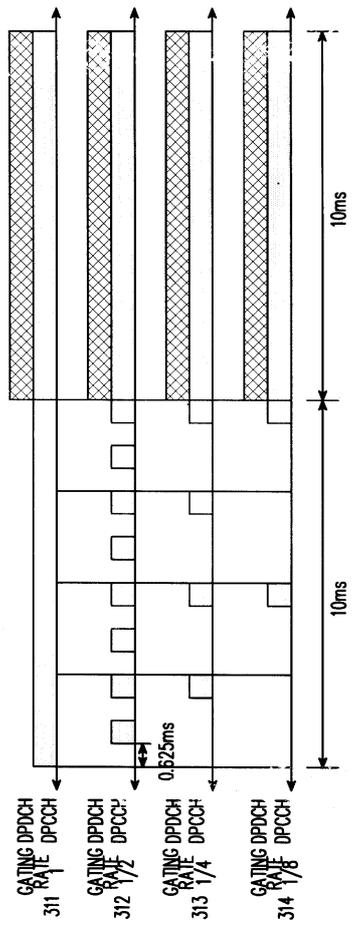

7b

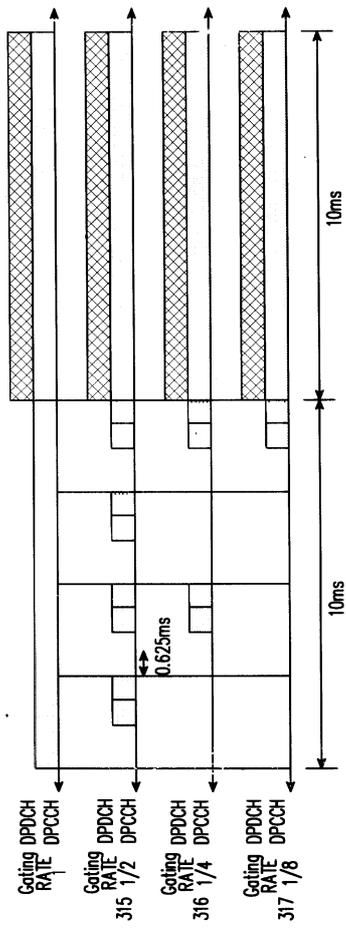

8a

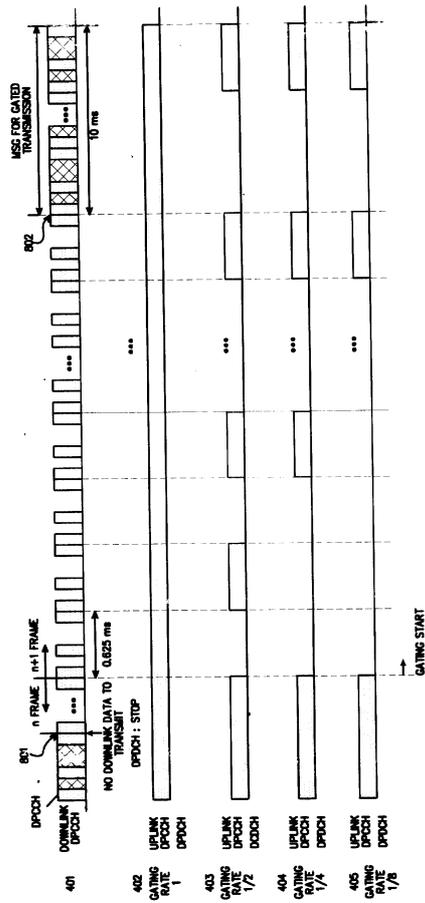

8b

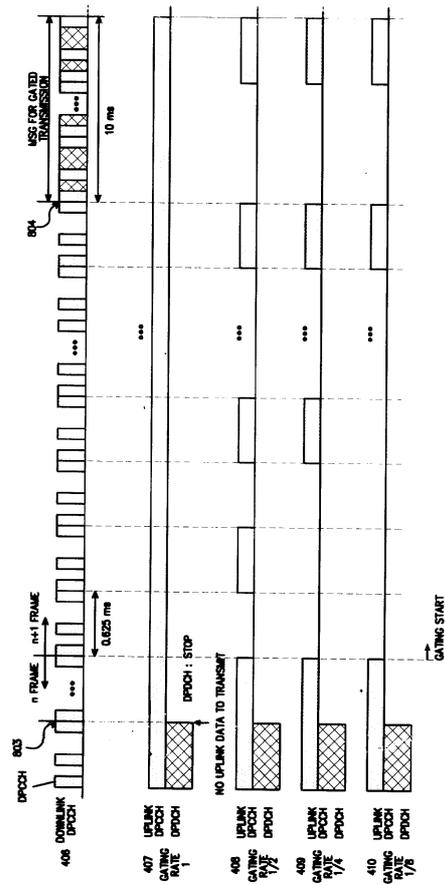

8c

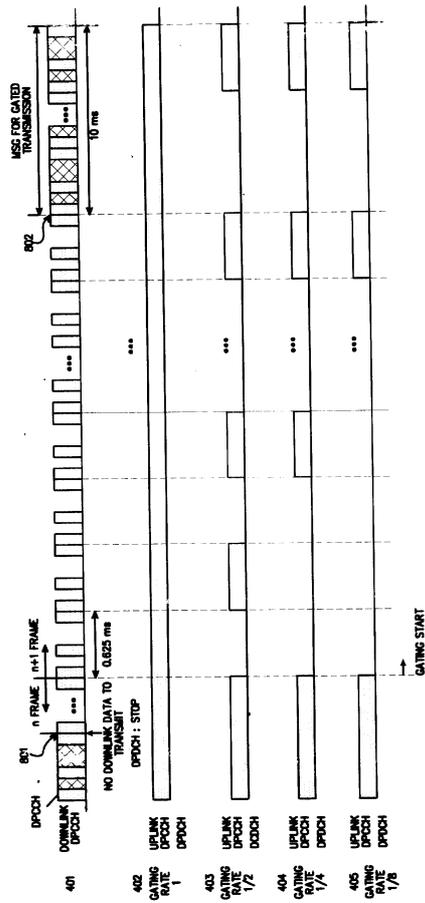

8d

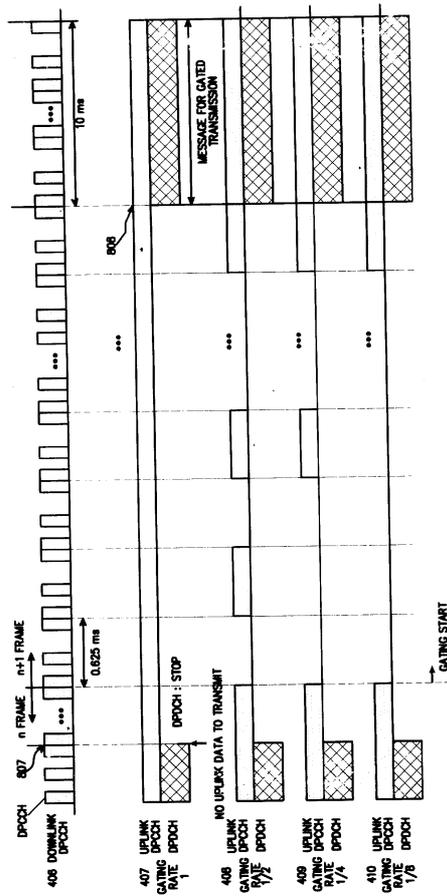

9a

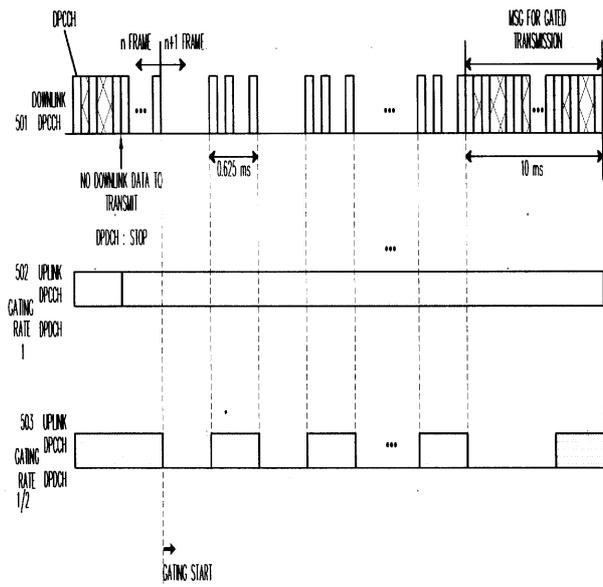

9b

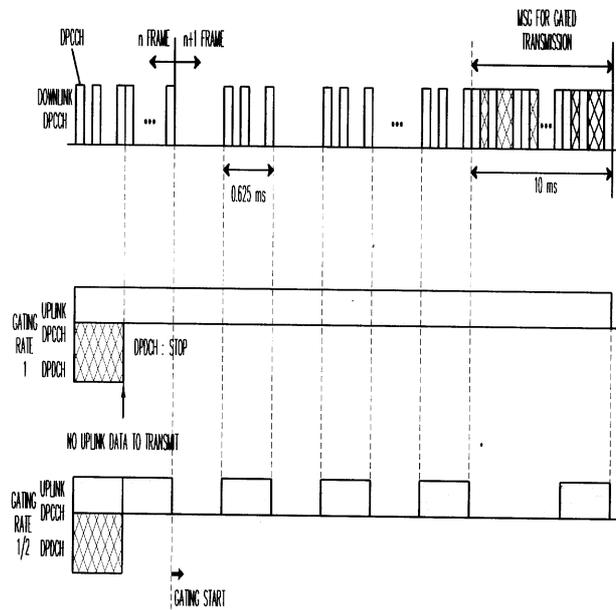

10a

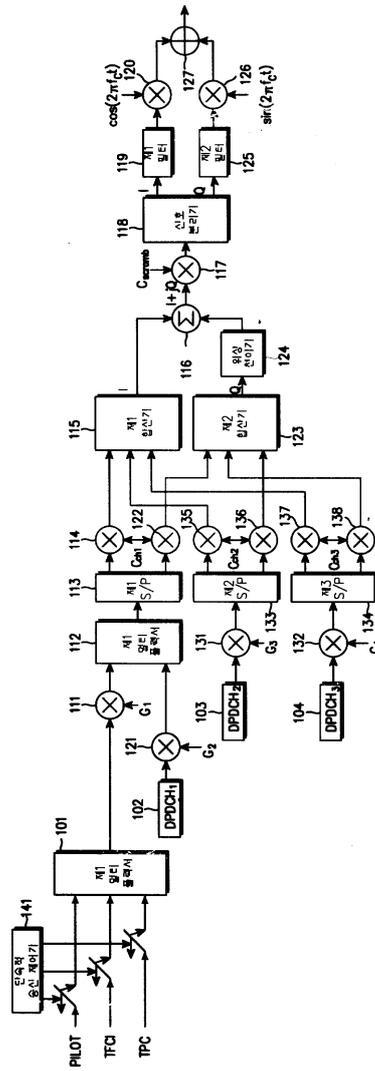

10b

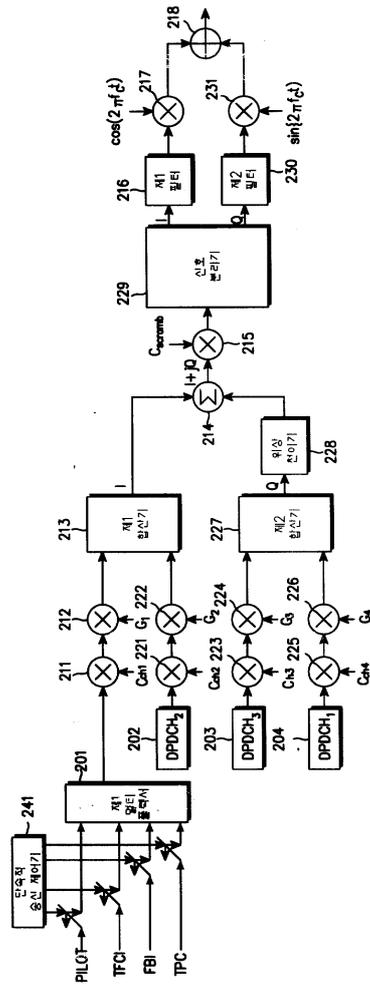

11a

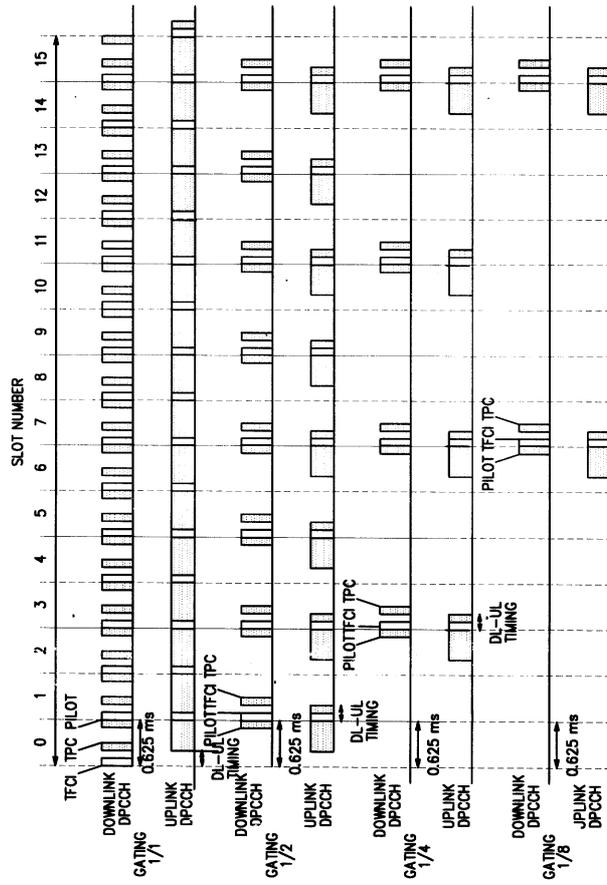

11b

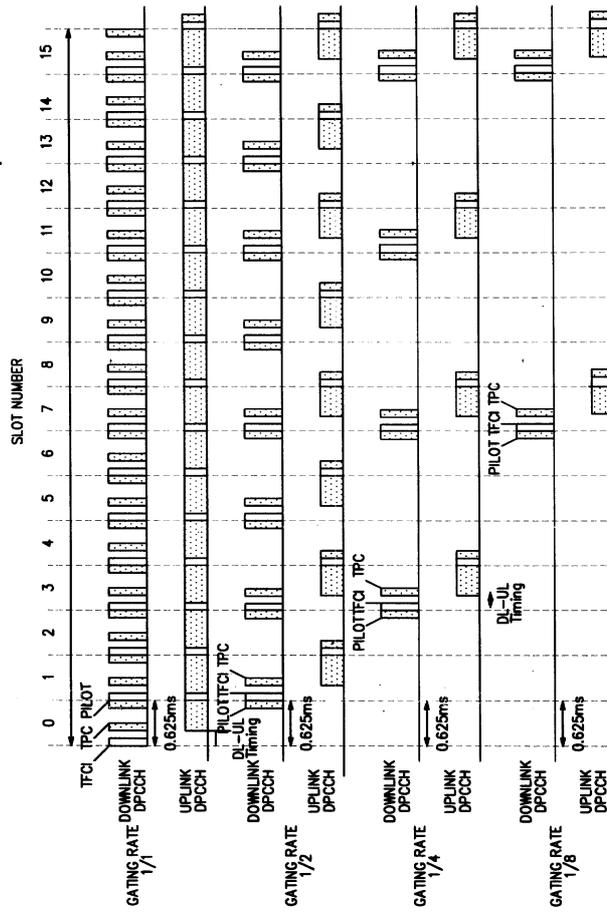

11c

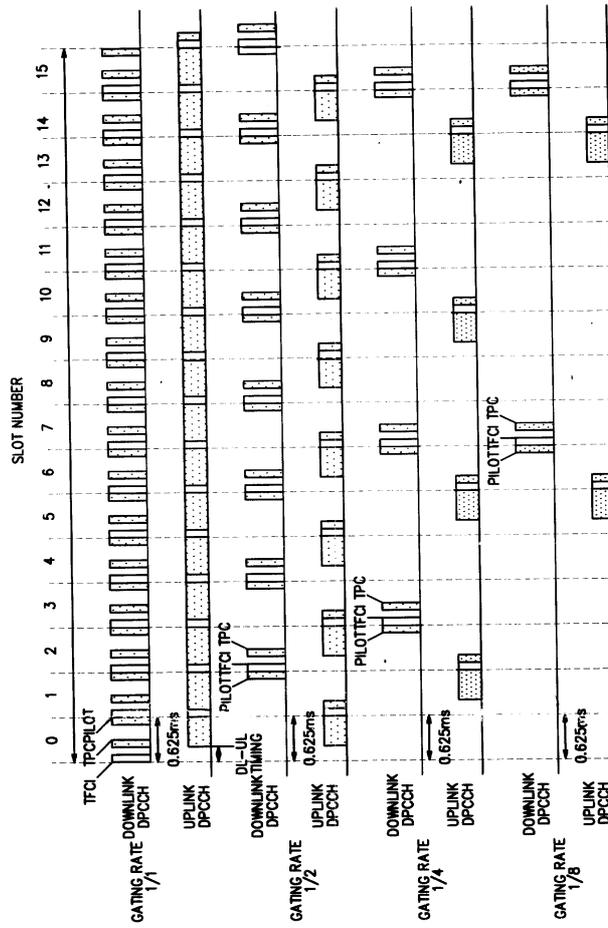

11d

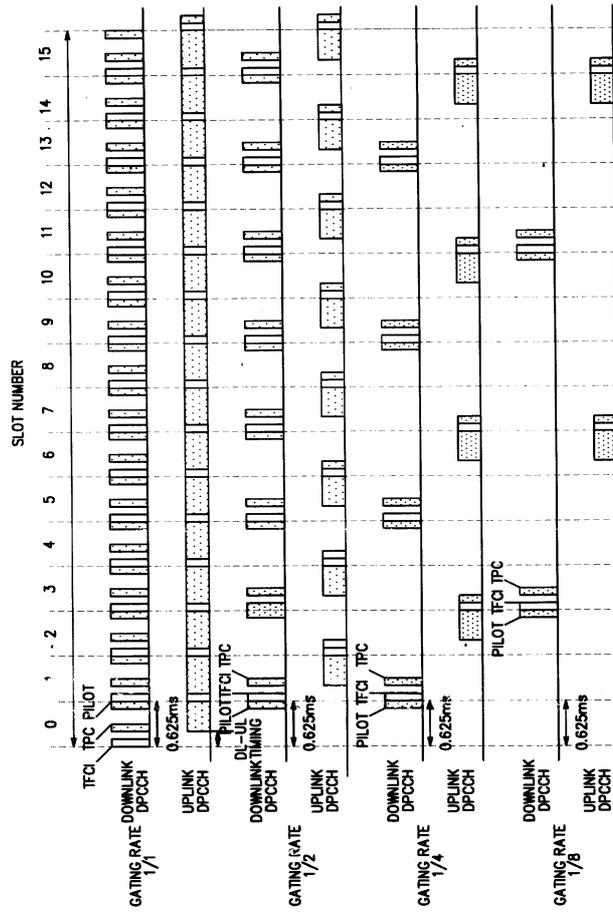

11e

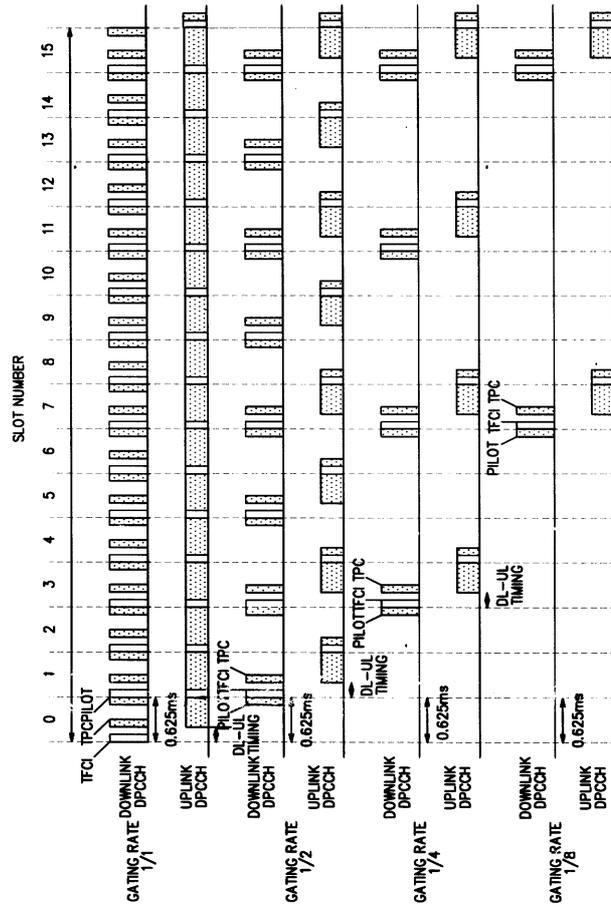

12a

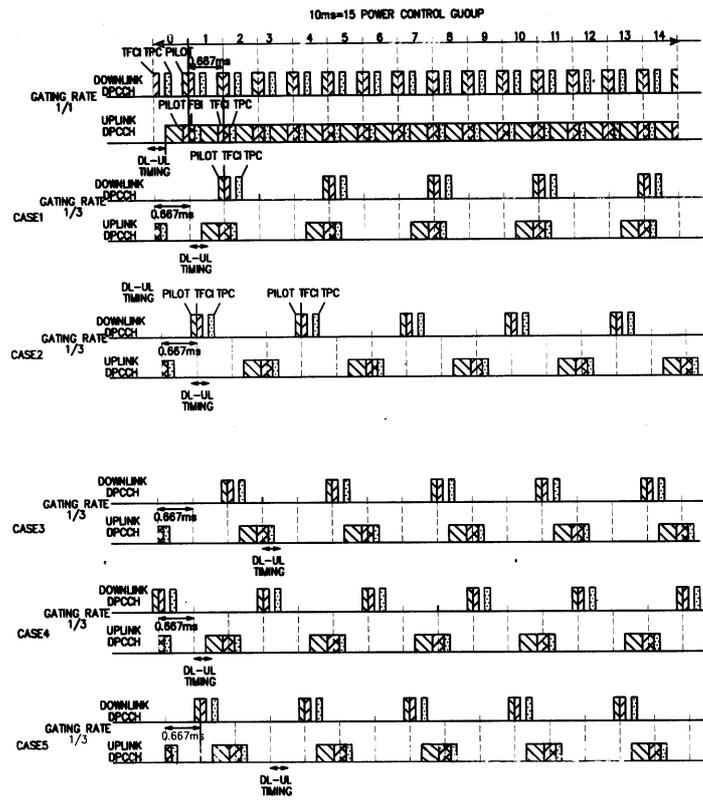

12b

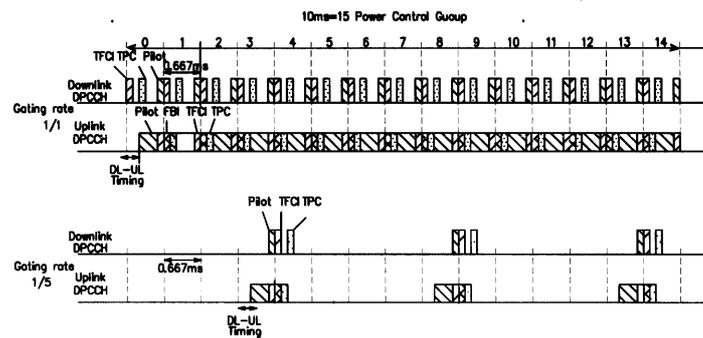

12c

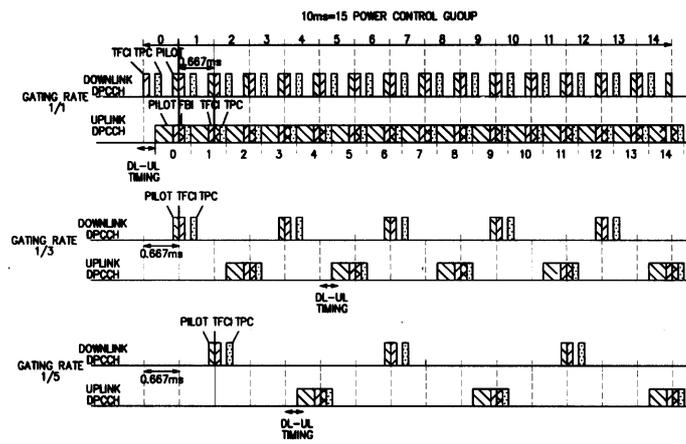

12d

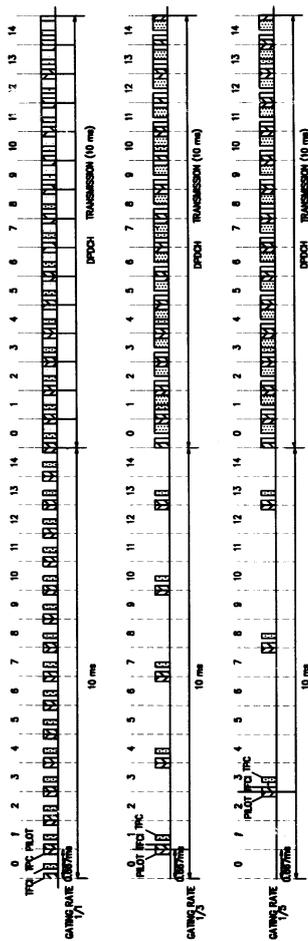

12e

