



INTERNATIONAL APPLICATION PUBLISHED UNDER THE PATENT COOPERATION TREATY (PCT)

<p>(51) International Patent Classification⁶ : A61M 37/00</p>	<p>A1</p>	<p>(11) International Publication Number: WO 98/35718 (43) International Publication Date: 20 August 1998 (20.08.98)</p>
<p>(21) International Application Number: PCT/US98/02586 (22) International Filing Date: 12 February 1998 (12.02.98) (30) Priority Data: 60/038,361 13 February 1997 (13.02.97) US (71) Applicant: SHERWOOD MEDICAL COMPANY [US/US]; 1915 Olive Street, St. Louis, MO 63103 (US). (72) Inventors: WEILBACHER, Eugene, E.; 1312 Bridge Creek Trail, Ellisville, MO 63021 (US). SWISHER, David, Rork; 372 Clarendon Lane, St. Charles, MO 63301 (US). (74) Agents: SMITH, Montgomery, W.; American Home Products Corporation, One Campus Drive, Parsippany, NJ 07054 (US) et al.</p>		<p>(81) Designated States: AL, AM, AT, AU, AZ, BA, BB, BG, BR, BY, CA, CH, CN, CU, CZ, DE, DK, EE, ES, FI, GB, GE, GH, HU, IL, IS, JP, KE, KG, KP, KR, KZ, LC, LK, LR, LS, LT, LU, LV, MD, MG, MK, MN, MW, MX, NO, NZ, PL, PT, RO, RU, SD, SE, SG, SI, SK, SL, TJ, TM, TR, TT, UA, UG, UZ, VN, YU, ZW, ARIPO patent (GH, GM, KE, LS, MW, SD, SZ, UG, ZW), Eurasian patent (AM, AZ, BY, KG, KZ, MD, RU, TJ, TM), European patent (AT, BE, CH, DE, DK, ES, FI, FR, GB, GR, IE, IT, LU, MC, NL, PT, SE), OAPI patent (BF, BJ, CF, CG, CI, CM, GA, GN, ML, MR, NE, SN, TD, TG).</p> <p>Published <i>With international search report.</i></p>

(54) Title: BLOOD EVACUATING SYSTEM AND METHOD OF USE THEREOF

(57) Abstract

The invention relates to an apparatus and method for a blood evacuation system (14) comprising an inner flexible blood evacuation bag (38) inside an outer rigid container (16) for reinfusing shield blood drawn from the collection chamber of a chest drainage unit (12). The outer rigid container (16) includes a suction port connected to a source of vacuum for applying a negative pressure within the interstitial space (46) between the interior surface of the rigid container (16), and the outside of the inner flexible blood evacuation bag (38). The negative pressure inside the interstitial space (46) draws blood from the collection chamber of the chest drainage unit (12) into the blood evacuation bag (38). Once the blood evacuation bag (38) is filled to a desired level, the inner flexible bag (38) is removed from the outer rigid container (16), and suspended using a suspension means (19) within the vicinity of a patient (10) for reinfusion. During reinfusion another blood evacuation bag (38) can replace the blood evacuation bag (38) being used for reinfusion.

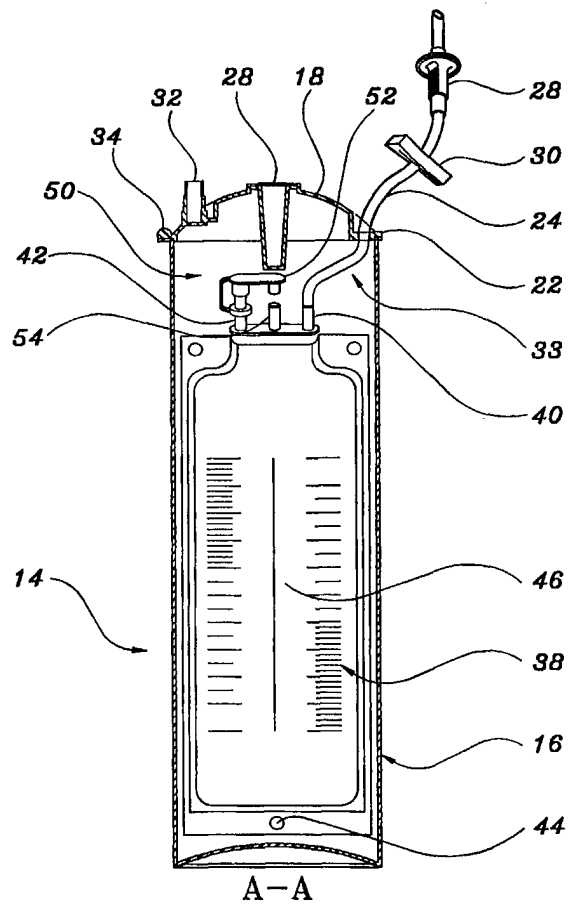

FOR THE PURPOSES OF INFORMATION ONLY

Codes used to identify States party to the PCT on the front pages of pamphlets publishing international applications under the PCT.

AL	Albania	ES	Spain	LS	Lesotho	SI	Slovenia
AM	Armenia	FI	Finland	LT	Lithuania	SK	Slovakia
AT	Austria	FR	France	LU	Luxembourg	SN	Senegal
AU	Australia	GA	Gabon	LV	Latvia	SZ	Swaziland
AZ	Azerbaijan	GB	United Kingdom	MC	Monaco	TD	Chad
BA	Bosnia and Herzegovina	GE	Georgia	MD	Republic of Moldova	TG	Togo
BB	Barbados	GH	Ghana	MG	Madagascar	TJ	Tajikistan
BE	Belgium	GN	Guinea	MK	The former Yugoslav Republic of Macedonia	TM	Turkmenistan
BF	Burkina Faso	GR	Greece	ML	Mali	TR	Turkey
BG	Bulgaria	HU	Hungary	MN	Mongolia	TT	Trinidad and Tobago
BJ	Benin	IE	Ireland	MR	Mauritania	UA	Ukraine
BR	Brazil	IL	Israel	MW	Malawi	UG	Uganda
BY	Belarus	IS	Iceland	MX	Mexico	US	United States of America
CA	Canada	IT	Italy	NE	Niger	UZ	Uzbekistan
CF	Central African Republic	JP	Japan	NL	Netherlands	VN	Viet Nam
CG	Congo	KE	Kenya	NO	Norway	YU	Yugoslavia
CH	Switzerland	KG	Kyrgyzstan	NZ	New Zealand	ZW	Zimbabwe
CI	Côte d'Ivoire	KP	Democratic People's Republic of Korea	PL	Poland		
CM	Cameroon	KR	Republic of Korea	PT	Portugal		
CN	China	KZ	Kazakstan	RO	Romania		
CU	Cuba	LC	Saint Lucia	RU	Russian Federation		
CZ	Czech Republic	LI	Liechtenstein	SD	Sudan		
DE	Germany	LK	Sri Lanka	SE	Sweden		
DK	Denmark	LR	Liberia	SG	Singapore		
EE	Estonia						

Blood Evacuating System and Method of Use Thereof

TECHNICAL FIELD

The present invention relates generally to an apparatus and method for collecting fluids and the reinfusion of the fluids to a patient, and particularly to a blood evacuation system adapted for autotransfusion. More specifically, the present invention is directed to a blood evacuation system that permits a disposable inner evacuation bag to be separated from an outer container for reinfusion so that another evacuation bag may be inserted inside the container to continue blood evacuation.

BACKGROUND ART

Blood evacuating apparatuses are commonly used in autotransfusion to evacuate and collect autologous blood from the collection chamber of a chest drainage unit. Autotransfusion refers to the reinfusion of a patient's own blood, known as autologous blood. Autotransfusion is the preferred method of reinfused since the blood being transfused is the patient's own blood, therefore eliminating problems over blood type incompatibility and exposure to blood carrying diseases such as hepatitis, AIDS, etc. Moreover, autologous blood is more fresh than stored blood supplied by a donor and also contains the patient's own antibodies.

One type of autotransfusion, referred to as "post-operative" autotransfusion, is the transfusion of the patient's own shed blood following surgery where drained

blood is collected and reinfused into the patient. Post-operative autotransfusion is limited in use since there are strict guidelines for the kind of blood which can be reinfused. Currently, the only post-operative blood believed
5 suitable for autotransfusion is mediastinal blood, i.e. the blood which comes from the anatomical space or cavity in the chest.

Presently, chest drainage units are commonly used in the post-operative care of patients having surgery
10 involving the chest cavity. Chest drainage units remove fluids and air from inside the chest cavity using tubing connected to the patient's chest cavity which drains the fluid and air into a collection chamber of the chest
15 drainage unit. The chest drainage unit is attached to a source of vacuum which applies a suction to the tubing and draws the trapped fluid and air from the chest cavity and into the collection chamber. Once collected, the blood may be evacuated from the collection chamber using an
autotransfusion pump or blood evacuation bag.

20 The use of a blood evacuation bag in autotransfusion is well known in the art. For example, U.S. Patent No. 5,380,314 to Herweck et al. discloses a blood collection bag having an internal spring that resiliently biases the bag into a fixed shape prior to use while concurrently inducing
25 a negative pressure therein in order to manually draw blood from the collection chamber of the chest drainage unit. However, one disadvantage with the '314 apparatus is that reinfusion must be accomplished using gravity means, whereby the bag is suspended in the vicinity of the patient and

gravity is allowed to drain the collected blood from the bag for reinfusion to the patient. Unfortunately, the '314 apparatus will not properly drain unless the user first takes the extra step of bleeding in ambient air into the blood collection bag prior to reinfusion. This bleeding step is necessary in order to force collected blood inside the rigid blood collection bag to drain, otherwise the force of gravity alone will prove insufficient to draw blood from the bag during reinfusion.

Another example of a blood evacuation system is found in U.S. Patent No.5,201,703 to Gentelia et al. which discloses an apparatus for collecting blood from a chest drainage unit and reinfusion of the blood to the patient. The '703 patent is directed to a self-contained, totally disposable apparatus comprising an rigid outer container housing an integrally attached flexible bag for use with a chest drainage unit. Negative pressure is applied or maintained inside the interstitial space between the rigid container and the inner flexible bag for causing blood stored in the collection chamber to be drawn into the bag. As drawn blood travels through tubing connecting the '703 apparatus to the chest drainage unit, it begins to fill the flexible inner bag. Once the bag is filled to a desired level with blood the entire apparatus, including the outer rigid container and the blood-filled inner bag, are disconnected from the chest drainage unit and suspended from a suitable suspension means in the vicinity of a patient for reinfusion of the collected blood.

However, a disadvantage with the '703 apparatus is that the entire apparatus must be employed during reinfusion. Specifically, both the outer rigid container and the inner flexible bag are utilized during the reinfusion process
5 since the '703 apparatus has a unitary design wherein the inner flexible bag cannot be separated from the outer rigid container. As a result, another entire apparatus - a container and evacuation bag - must replace the used apparatus in order to continue the autotransfusion procedure
10 on the same patient. Accordingly, the cost to the user is higher since the entire apparatus must be replaced after each transfusion.

Another disadvantage to the '703 apparatus is that the conventional means for attaining higher rates of reinfusion
15 with the above noted blood evacuation systems are sometimes not possible. A prior art blood evacuation bag that fixedly attaches the evacuation bag to the outer rigid container or is made of a unitary, rigid container design are not adapted to employ high reinfusion rate techniques. For example, it
20 is well known in the art that pressure cuffs wrapped around a flexible blood evacuation bag can generate higher reinfusion rates by applying pressure to a bladder of the pressure cuff surrounding the container. However, if the evacuation container is of a rigid design a pressure cuff
25 surrounding the container is unable to exert sufficient pressure to collapse the inner flexible bag and generate a higher rate of reinfusion. In view of these disadvantages regarding cost and performance, it is desirable to have a blood evacuation system in which only the inner flexible bag

is used to reinfuse blood while the rigid outer container remains connected to a vacuum source for further collection of blood from the chest drainage unit.

Accordingly, a need exists in the art for a blood
5 evacuation system that permits detachment of the inner flexible bag from the outer rigid container before reinfusion so that another flexible bag may be used inside the same container in order to collect further blood from the collection chamber. Moreover, there also exists a need
10 in the art for a blood evacuation system that provides a cost effective means of reinfusing blood to a patient using multiple, detachable evacuation bags to continue blood evacuation while reinfusion takes place.

DISCLOSURE OF INVENTION

15 A principle object of the present invention is to provide a cost-effective means of reinfusing blood to a patient.

Another object of the present invention is to provide an efficient method of reinfusing autologous blood to a
20 patient.

A further object of the present invention is to provide a blood evacuation system that includes an inner flexible bag that is separable from its outer container during reinfusion.

25 Another further object of the present invention is to provide a separable evacuation bag that is adapted to receive a pressure cuff for generating a higher rate of reinfusion.

These and other objects of the present invention are realized in a presently preferred embodiment thereof, described by way of example and not by way of limitation, which provides for an apparatus and related method for

5 evacuating and reinfusing blood to a patient using a blood evacuation system comprising a separable, flexible inner bag inside an outer rigid container for reinfusing shed blood drawn from the collection chamber of a chest drainage unit. The outer rigid container includes a suction port connected

10 to a source of vacuum for applying a negative pressure within the interstitial space between rigid container and the inner flexible bag disposed therein. The negative pressure maintained within the interstitial space inside the container causes blood to be drawn into the bag from the

15 collection chamber of the chest drainage unit through tubing which maintains fluid flow communication between the bag and the collection chamber. Once the bag is filled to a desired level, the inner flexible bag is removed from the outer rigid container and suspended within the vicinity of a

20 patient for reinfusion of the collected blood.

BRIEF DESCRIPTION OF DRAWINGS

FIG. 1 is a simplified block diagram showing the blood evacuation system according to the present invention;

FIG. 2 is a perspective view of the rigid outer container and transfer tubing according to the present invention;

25

FIG. 3 is a partial cross section view of the rigid outer container showing the blood evacuation bag according to the present invention; and

FIG. 4 is a perspective view of the blood evacuation bag according to the present invention.

MODE(S) FOR CARRYING OUT THE INVENTION

Referring to FIG. 1, a simplified block diagram of an autotransfusion system 11 is illustrated showing the constituent elements of system 11. The autotransfusion system 11 comprises a patient 10 in fluid flow communication with a drainage device 12 using transfer tubing 24 to maintain fluid flow therebetween in direction A. The autotransfusion system 11 further includes a blood evacuation system 14 according to the present invention that is in fluid flow communication with the drainage device 12 using the same type of transfer tubing 24 used between the patient 10 and the device 12. Preferably, the transfer tubing 24 is made of a flexible plastic material, although any flexible material suitable for transporting fluid, such as blood, is felt to fall within the scope of the present invention.

Referring to FIGS. 2 and 3, the blood evacuation system 14 according to the present invention is shown. The blood evacuation system 14 comprises a rigid canister 16 with a flexible blood evacuation bag 38 disposed therein. Preferably, the canister 16 has a generally round shape, although any shaped container suitable for storing fluid is felt to fall within the scope of the present invention. The canister 16 includes a lid 18 that is attached to a canister

body 21 by hinges 34 which permits the lid 18 to swing freely about the hinges 34 when opening and closing the canister 16. The canister 16 also includes a labeling area 20 on the outer surface. Preferably, the labeling area 20 includes a surface area for displaying instructions on the use of the blood evacuation system 14 for the user. The lid 18 of canister 16 has a dome-like shape with a suction port 32 in communication with the interior space 46 inside the canister 16. The lid 18 further includes a tubing groove 22 along the rim of lid 18 and a spike cover nest 28 formed in the middle of lid 18 for storing a spike cover (not shown) therein. The tubing groove 22 provides an opening whereby the transfer tubing 24 attached to the blood evacuation bag 38 is inserted therethrough and connected to the blood evacuation bag 38 to establish fluid flow communication with the collection chamber of drainage device 12. Although the tubing groove 22 does not maintain a hermetic seal inside the canister 16, sufficient negative pressure is maintained inside the interstitial space 50 between the canister 16 and the blood evacuation bag 28 to generate enough negative pressure inside the bag 28 for drawing blood into the blood evacuation bag 38.

The blood evacuation bag 38 disposed inside the canister 16 has a plurality of ports located at the top portion of the bag 38. One port, a reinfusion port 42, is closed and covered with a cap 52 and provides a site for draining collected blood from the blood evacuation bag 38 after the bag 38 is separated from the canister 16 during the reinfusion procedure. Another port, a collection port

40, is provided for attachment to the transfer tubing 24 leading from the drainage device 12 for the evacuation of blood therefrom.

Referring to FIG. 4, the blood evacuation bag 38 shall
5 be discussed in greater detail. The blood evacuation bag 38 includes an expandable interior space 46 used for the evacuation of shed blood from the drainage device 12. As shed blood is collected inside the interior space 46 of the blood evacuation bag 38, the space 46 expands until the bag
10 38 is filled to the desired level. A hole 44 located at the bottom portion of the blood evacuation bag 38 below the interior space 46 serves as a site for suspending the bag 38 from a suitable suspension means (not shown) during reinfusion. A clamp 30 is also provided to prevent fluid
15 flow through the transfer tubing 24 when the user wishes to stop the flow of blood into the blood evacuation bag 38 and to also prevent fluid flow from the bag 38 prior to reinfusion. Preferably, the blood evacuation bag 38 according to the present invention may be manufactured from
20 any clear, flexible plastic material, although any material suitable for collecting and reinfusing fluid, like blood, is felt to fall within the scope of the present invention.

In establishing fluid flow communication between the blood evacuation bag 38 and the drainage device 12, a user
25 engages a spike port (not shown) leading from the collection chamber of the drainage device 12 with a blood spike 26. The blood spike 26 is attached to a spike port (not shown) attached to the distal end of the transfer tubing 24 leading from the blood evacuation bag 38. Prior to engaging the

spike port, a dust cover 56 that caps the blood spike 26 during storage and transportation after manufacture is removed. Once the user engages the blood spike 26 to the spike port, a source of vacuum is applied to the suction
5 port 32. When vacuum is applied to the inside of canister 16, negative pressure builds inside the interstitial space 50 between the inner surface of canister 16 and the outside surface of blood evacuation bag 38 inside the canister 16. With sufficient pressure decrease, blood collected inside
10 the drainage device 12 flows through the transfer tubing 24 and fills the interior space 46 of the blood evacuation bag 38.

Once the blood evacuation bag 38 is filled to a desired level reinfusion of the blood may take place. The reinfusion
15 procedure begins by the user applying the clamp 30 to the transfer tubing 24 and turning off the source of vacuum to the canister 16, thereby preventing fluid flow therethrough from the drainage device 12. After the transfer tubing 24 is clamped, the blood spike 26 is disengaged from the spike
20 port and properly encapsulated using a spike cover (not shown) stored inside the nest 28 of the canister 16 to protect the contaminated pointed end 31 of the spike 26 after use. After encapsulating the blood spike 26, the lid 18 is opened and the blood evacuation bag 38 is removed from
25 the canister 16 and suspended in the vicinity of the patient using suitable suspension means, for example an IV pole. Once suspended, the user establishes fluid flow communication between the patient and the blood evacuation bag 38 by removing the cap 48 from the reinfusion port 42

and connecting transfer tubing 24 between the patient and the port 42.

Reinfusion may occur by one of several methods. Preferably, the blood evacuation bag 38 is suspended above the patient and the shed blood allowed to drain from the bag 38 using the force of gravity alone to draw the blood through transfer tubing 24 and into patient 10. An alternative method of reinfusion is to apply a pressure cuff (not shown) around the blood evacuation bag 38 as it is suspended. As the user applies pressure through a bladder of the pressure cuff, blood inside the blood evacuation bag 38 is forced out and a higher rate of reinfusion is attained due to the increased pressure. Preferably, a suspension means 19 is provided on the outer surface of canister body 21 and includes a hook integrally formed at the top portion for suspending the blood evacuation system 14. Alternatively, a VELCRO support and corresponding VELCRO loop can be provided at the bottom portion of canister body 21 for suspending the blood evacuation bag 38 from a suitable suspension means.

While reinfusion is occurring, the user may continue evacuating blood from the drainage device 12 by inserting another blood evacuation bag 38 into the canister 16 and reestablishing fluid flow communication between the bag 38 and the drainage device 12 as noted above. In this manner, "batch" autotransfusion takes place by simply replacing the blood evacuation bag 38 inside the canister 16 every time a bag 38 is removed for reinfusion.

It should be understood from the foregoing that, while particular embodiments of the invention have been illustrated and described, various modifications can be made thereto without departing from the spirit and scope of the invention. Therefore, it is not intended that the invention be limited by the specification; instead, the scope of the present invention is intended to be limited only by the appended claims.

CLAIMS

1. An evacuation system (14) for the collection of fluid from a drainage device (12) and reinfusion of those fluids to a patient comprising:

5 a container (16), said container (16) including an open top and lid (18) for sealing said open top of said container (16), said lid (18) including a port (32) located at the top portion thereof, said port (32) being adapted for connection to a source of vacuum for applying and maintaining a
10 negative pressure inside said container (16) for causing fluid to be drawn into said container (16), and

a flexible bag (38) disposable within said container (16) and separable from said container (16), said flexible bag (38) having a plurality of ports (42, 40, 54), one of
15 said plurality of ports (40) being in fluid flow communication with a drainage device (12) for drawing in fluid from said drainage device (12) when said source of vacuum is applied and collecting fluid into said flexible bag (38), another one of said ports (42) being adapted for
20 reinfusion of said collected fluid to a patient,

wherein said flexible bag (38) is removable from said container (16) for reinfusion of fluid to a patient.

2. The evacuation system (14) according to claim 1, wherein said negative pressure is applied to an interstitial space
25 between an interior surface of said container (16) and an exterior surface of said flexible bag (38), said negative pressure causing fluid to be drawn from the drainage device (12) and into the flexible bag (38).

3. The evacuation system (14) according to claim 1, wherein one of said plurality of ports (40, 42, 54) is adapted for use as a gravity drain for draining fluid from said flexible bag (38) during reinfusion.

5 4. The evacuation system (14) according to claim 4, wherein said port (32) is formed on said lid (18), said port (32) communicating with the inside of said container (16).

5. The evacuation system (14) according to claim 4, wherein said lid (18) is hingeable to said container (16).

10 6. The evacuation system (14) according to claim 1, wherein said fluid flow communication between the drainage device (12) and one of said plurality of ports (40, 42, 54) is maintained by tubing (29) attached therebetween.

7. A method of reinfusing fluid back to a patient (10), the
15 steps of the method comprising:

a) establish fluid flow communication between a receptacle (38) housed in a container (16) and a source of fluid for the collection of said fluid into said receptacle (38) to a predetermined level;

20 b) close off fluid flow communication between said receptacle (38) and said source of fluid once the predetermined level of fluid is collected inside said receptacle (38);

c) disengage said receptacle (38) from said source of
25 fluid and open a lid (18) of said container (16);

d) remove said receptacle (38) from said container (16) and suspend said receptacle (38) in the vicinity of the patient (10); and

e) establish fluid flow communication between the patient (10) and said receptacle (38) and reinfuse said fluid back into the patient (10).

8. The method according to claim 7, wherein said step of establishing fluid flow communication between said receptacle (38) and said source of fluid further includes applying a source of vacuum within the interior space (46) separating said receptacle (38) from said container (16).

9. The method according to claim 7, wherein said step of establishing fluid flow communication between said receptacle (38) and said source of fluid further includes engaging a tube (24) connected to said receptacle (38) with a tube (24) connected to said source of fluid.

10. The method according to claim 7, wherein said step of disengaging said receptacle (38) from said source of fluid further includes sealing off a free end of a tube (24) connected to said receptacle (38) after disengagement occurs.

11. The method according to claim 10, wherein sealing said free end of said tube (24) connected to said receptacle (38) further includes encapsulating a spike (26) attached to said

free end of said tube (24) connected to said receptacle (38).

12. The method according to claim 7, wherein said step of disengaging further includes disengaging a spike (26)
5 attached to a free end of a tube (24) connected to said receptacle (38) from a port attached to a free end of a tube (24) connected to said source of fluid.

13. The method according to claim 7, wherein said step of disengaging further includes disengaging a spike (26)
10 attached to a free end of a tube (24) connected to said source of fluid from a port attached to a free end of a tube (24) connected to said receptacle (38).

14. The method according to claim 7, wherein said step of establishing fluid flow communication between the patient
15 (10) and said receptacle (38) further includes engaging a free end of a tube (24) connected to said receptacle (38) with a free end of a tube (38) connected to the patient (10).

15. The method according to claim 14, wherein said step of
20 establishing fluid flow communication further includes applying a pressure means around the outside of said receptacle (38) for forcing fluid from said receptacle (38) and into the patient (10) during reinfusion.

16. A method of reinfusing fluid back to a patient (10), the steps of the method comprising:

a) establish fluid flow communication between a first receptacle (38) housed in a container (16) and a source of fluid for the collection of said fluid into said first receptacle (38) to a predetermined level;

b) close off fluid flow communication between said first receptacle (38) and said source of fluid once the predetermined level of said fluid is collected inside said first receptacle (38);

c) disengage said first receptacle (38) from said source of fluid and open a lid (18) of said container (16);

d) remove said first receptacle (38) from said container (16) and suspend said first receptacle (38) in the vicinity of the patient (10);

e) establish fluid flow communication between the patient (10) and said first receptacle (38) and reinfuse said fluid back into the patient (10);

f) insert a second receptacle (38) into said container (16) and close said lid (18);

g) establish fluid flow communication between said second receptacle (38) and said source of fluid for the collection of said fluid into said second receptacle (38) to a predetermined level; and

h) repeat said steps (a) - (g) for as many receptacles (38) that are desired for reinfusion of fluid back to the patient (10).

17. The method according to claim 16, wherein said steps of establishing fluid flow communication between said as many receptacles (38) that are desired and said source of fluid further includes applying a source of vacuum within the interior space (46) separating said as many receptacles (38) that are desired from said container (16).

18. The method according to claim 16, wherein said steps of establishing fluid flow communication between said as many receptacles (38) that are desired and said source of fluid further includes engaging a tube (24) connected to said as many receptacles (38) that are desired with a tube (24) connected to said source of fluid.

19. The method according to claim 16, wherein said steps of disengaging said as many receptacles (38) that are desired from said source of fluid further includes sealing off a free end of a tube (24) connected to respective said as many receptacles (38) that are desired after disengagement occurs.

20. The method according to claim 19, wherein sealing said free end of said tube (24) connected to said as many receptacles (38) that are desired further includes encapsulating a spike (26) attached to said free end of said tube (24) connected to each of said as many receptacles (38) that are desired.

21. The method according to claim 16, wherein said step of disengaging further includes disengaging a spike (26) attached to a free end of a tube (24) connected to said as many receptacles (38) that are desired from a port attached
5 to a free end of a tube (24) connected to said source of fluid.

22. The method according to claim 16, wherein said step of disengaging further includes disengaging a spike (26) attached to a free end of a tube (24) connected to said
10 source of fluid from a port attached to a free end of a tube (24) connected to said as many receptacles (38) that are desired.

23. The method according to claim 16, wherein said step of establishing fluid flow communication between the patient
15 (10) and said as many receptacles (38) that are desired further includes engaging a free end of a tube (24) connected to said as many receptacles (38) that are desired with a free end of a tube (24) connected to the patient (10).

20 24. The method according to claim 14, wherein said step of establishing fluid flow communication further includes applying a pressure means around the outside of said as many receptacles (38) that are desired for forcing fluid from said as many receptacles (38) that are desired and into the
25 patient during reinfusion.

1/4

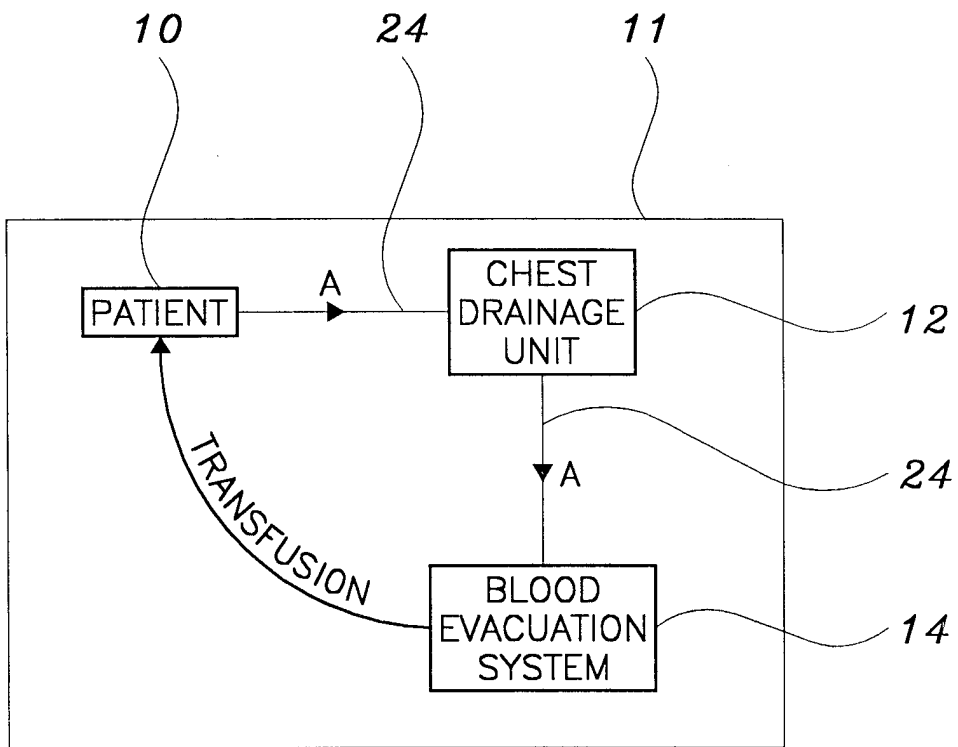

Figure 1

2/4

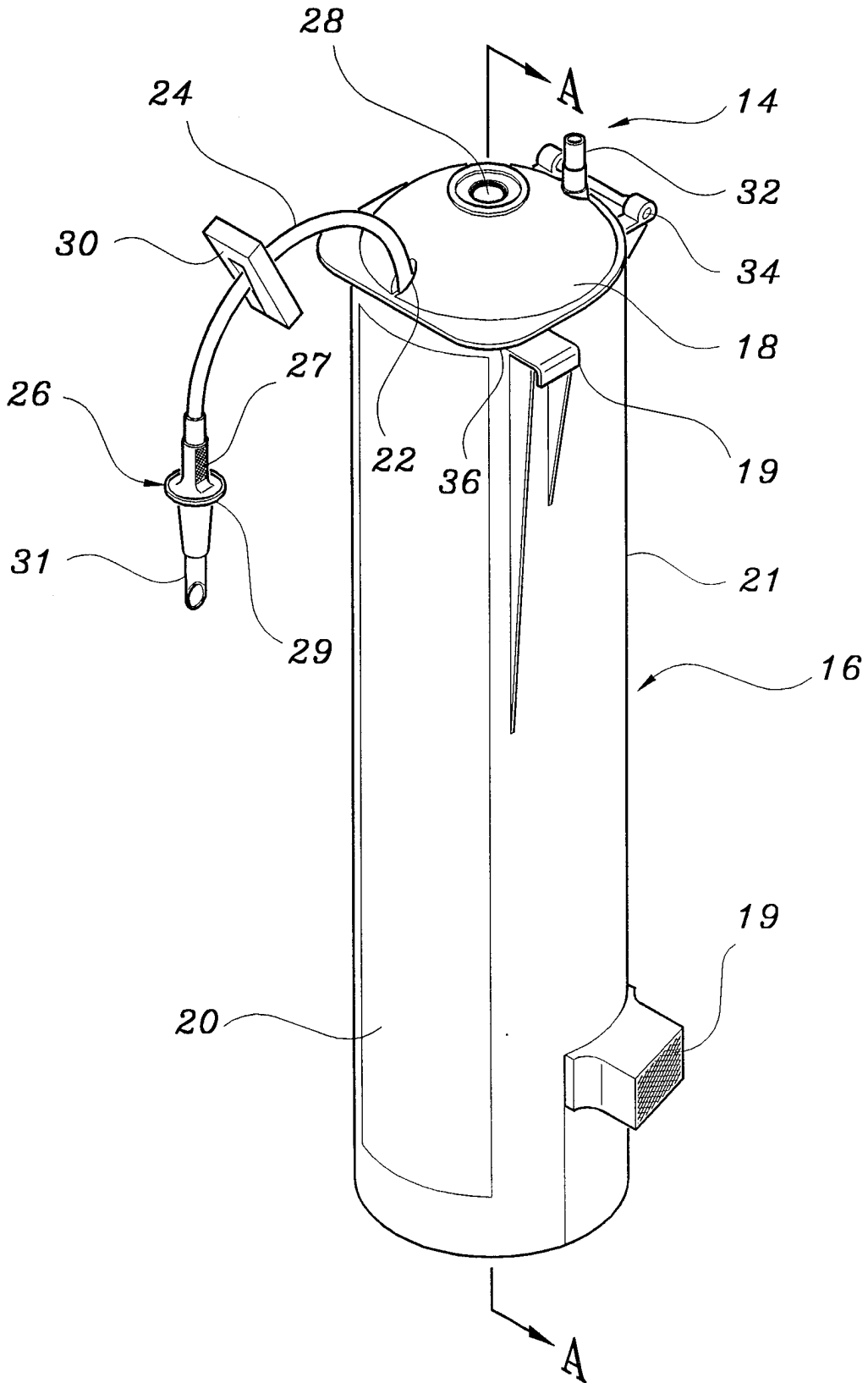

Figure 2

3/4

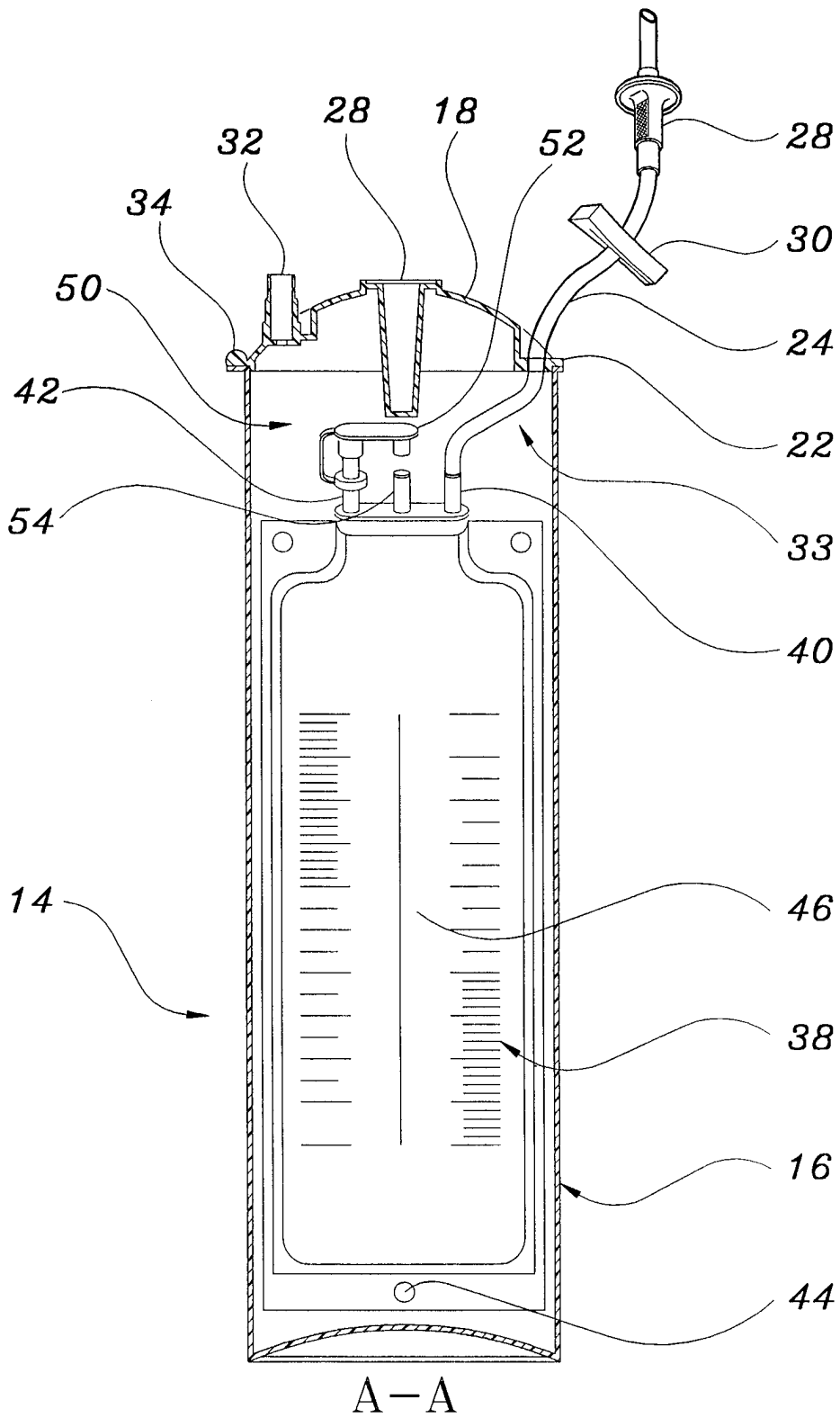

Figure 3

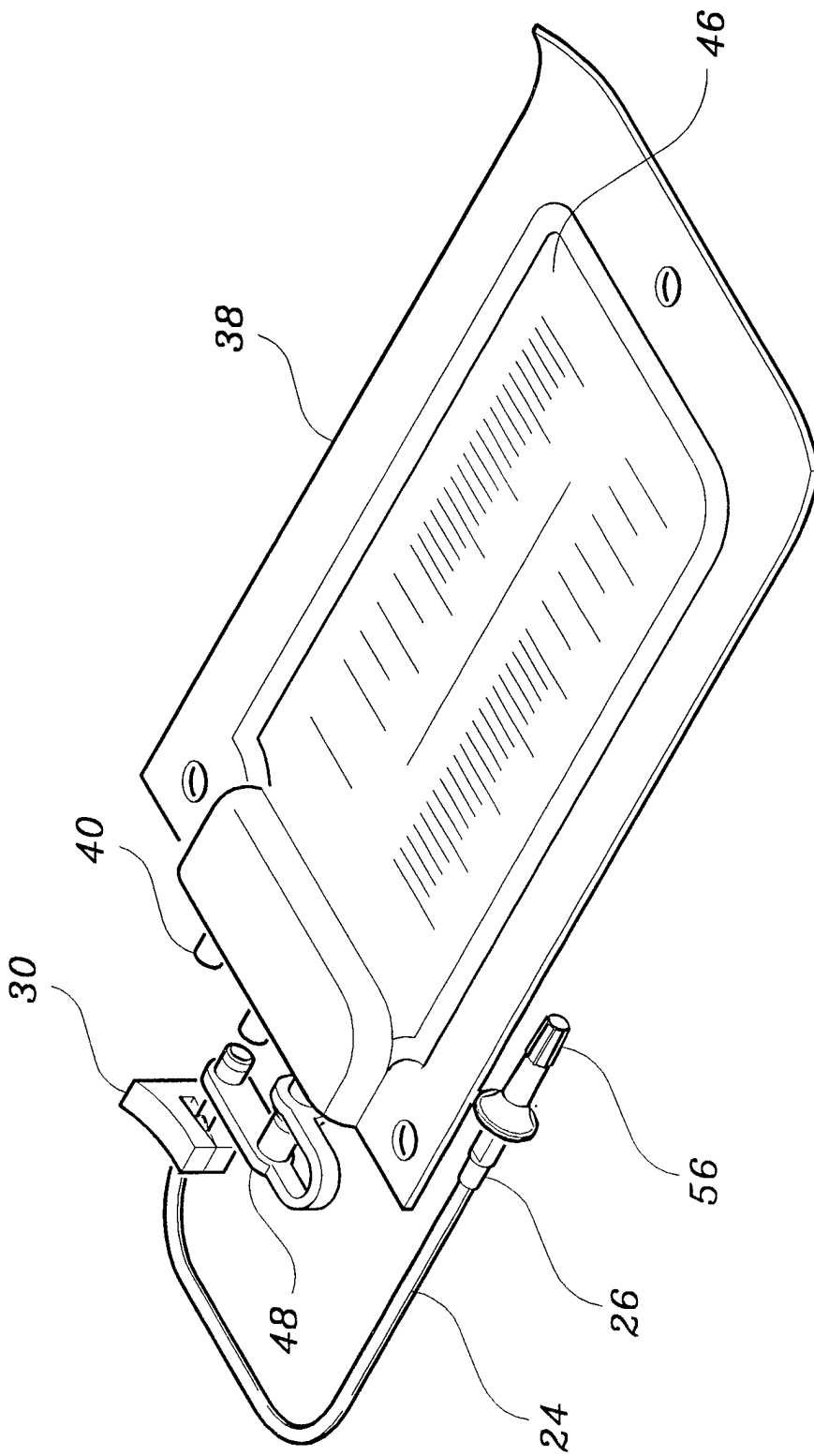

Figure 4

INTERNATIONAL SEARCH REPORT

International application No.
PCT/US98/02586

A. CLASSIFICATION OF SUBJECT MATTER
 IPC(6) : A61M 37/00
 US CL : 604/4, 119, 283, 319, 322
 According to International Patent Classification (IPC) or to both national classification and IPC

B. FIELDS SEARCHED
 Minimum documentation searched (classification system followed by classification symbols)
 U.S. : 55/159; 128/760, 762, 767; 604/4-6, 35, 49-52, 119, 131, 133, 283, 317-326, 403, 408

Documentation searched other than minimum documentation to the extent that such documents are included in the fields searched

Electronic data base consulted during the international search (name of data base and, where practicable, search terms used)
 APS

C. DOCUMENTS CONSIDERED TO BE RELEVANT

Category*	Citation of document, with indication, where appropriate, of the relevant passages	Relevant to claim No.
X	US 4,775,360 A (LANE et al.) 04 October 1988, entire document.	1-6
---		-----
Y		7-24
X	US 4,516,973 A (TELANG) 14 May 1985, Abstract, and Fig. 2.	1-6
X	US 4,522,623 A (LAUTERJIING) 11 June 1985, Fig. 1.	1-6
X	US 4,675,010 A (SIPOSS et al.) 23 June 1987, Abstract.	1-6
X	US 5,269,924 A (ROCHAT) 14 December 1993, Abstract, and Fig. 1.	1-6

Further documents are listed in the continuation of Box C. See patent family annex.

* Special categories of cited documents:	*T* later document published after the international filing date or priority date and not in conflict with the application but cited to understand the principle or theory underlying the invention
A document defining the general state of the art which is not considered to be of particular relevance	*X* document of particular relevance; the claimed invention cannot be considered novel or cannot be considered to involve an inventive step when the document is taken alone
E earlier document published on or after the international filing date	*Y* document of particular relevance; the claimed invention cannot be considered to involve an inventive step when the document is combined with one or more other such documents, such combination being obvious to a person skilled in the art
L document which may throw doubts on priority claim(s) or which is cited to establish the publication date of another citation or other special reason (as specified)	*&* document member of the same patent family
O document referring to an oral disclosure, use, exhibition or other means	
P document published prior to the international filing date but later than the priority date claimed	

Date of the actual completion of the international search 28 APRIL 1998	Date of mailing of the international search report 21 MAY 1998
--	---

Name and mailing address of the ISA/US Commissioner of Patents and Trademarks Box PCT Washington, D.C. 20231 Facsimile No. (703) 305-3230	Authorized officer <i>DAVID J. CHO</i> Telephone No. (703) 308-0073
--	---

INTERNATIONAL SEARCH REPORT

International application No.
PCT/US98/02586

C (Continuation). DOCUMENTS CONSIDERED TO BE RELEVANT

Category*	Citation of document, with indication, where appropriate, of the relevant passages	Relevant to claim No.
X, P	US 5,713,879 A (SCHNIEIDER) 03 February 1998, Abstract.	1-6