

J. A. SMITH.
Reed Organ Stop Action.
No. 241,740. Patented May 17, 1881.

Fig. 1.

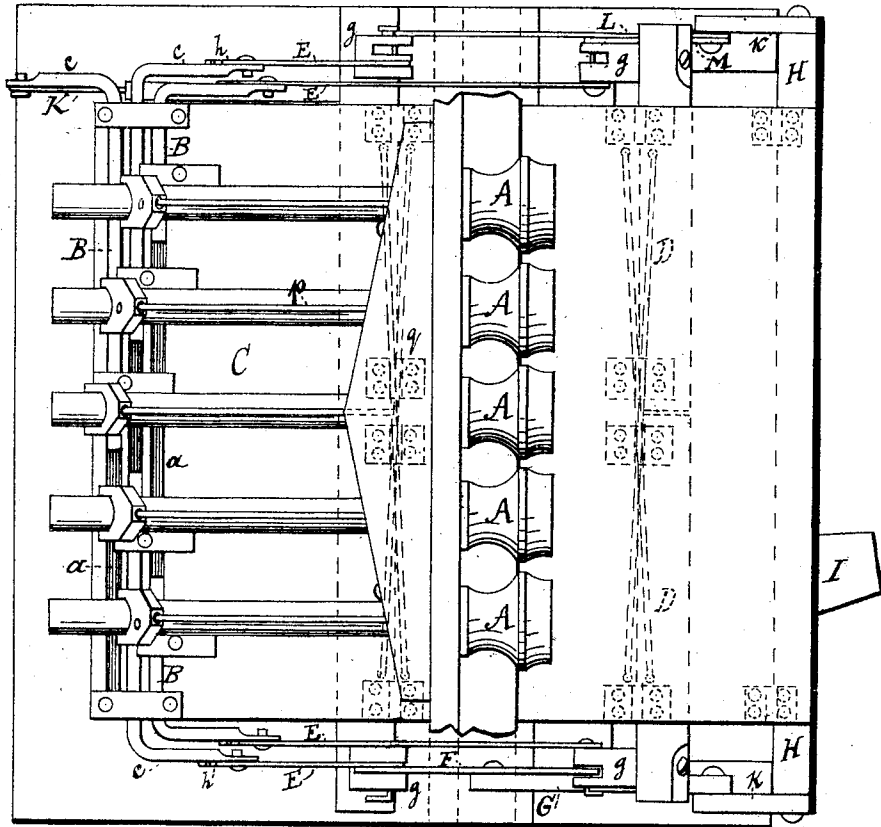
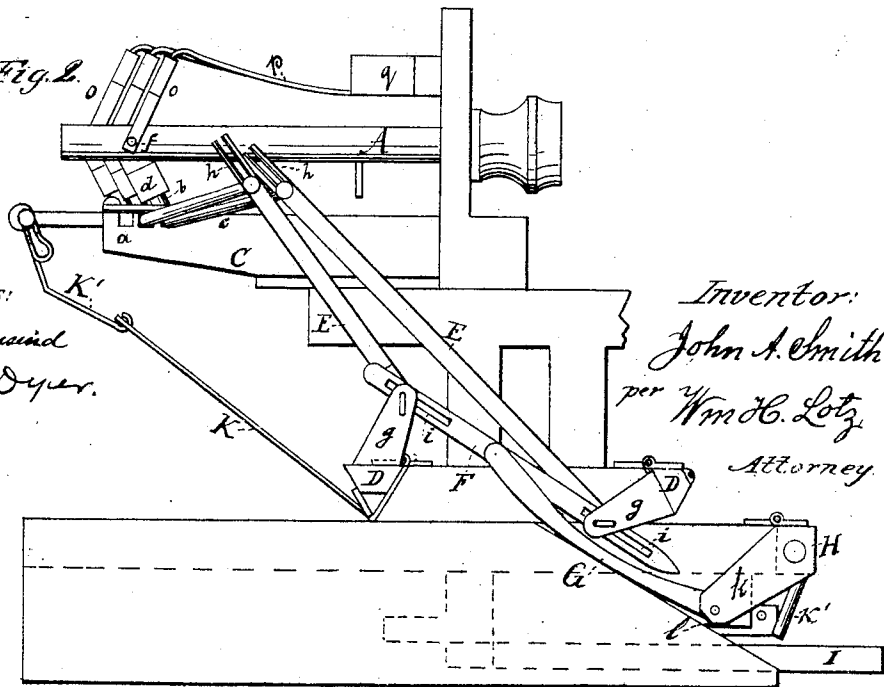

Fig. 2.



Witnesses:
F. B. Townsend
Rich^d. N. Dyer.

Inventor:
John A. Smith
per Wm C. Lotz
Attorney

J. A. SMITH.
Reed Organ Stop Action.
No. 241,740. Patented May 17, 1881.

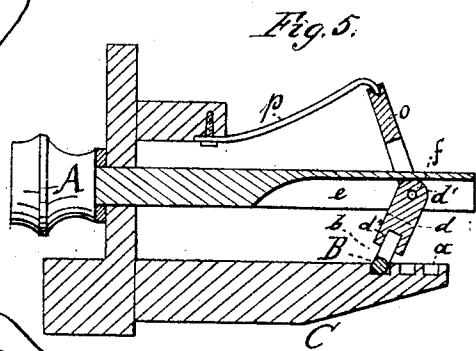
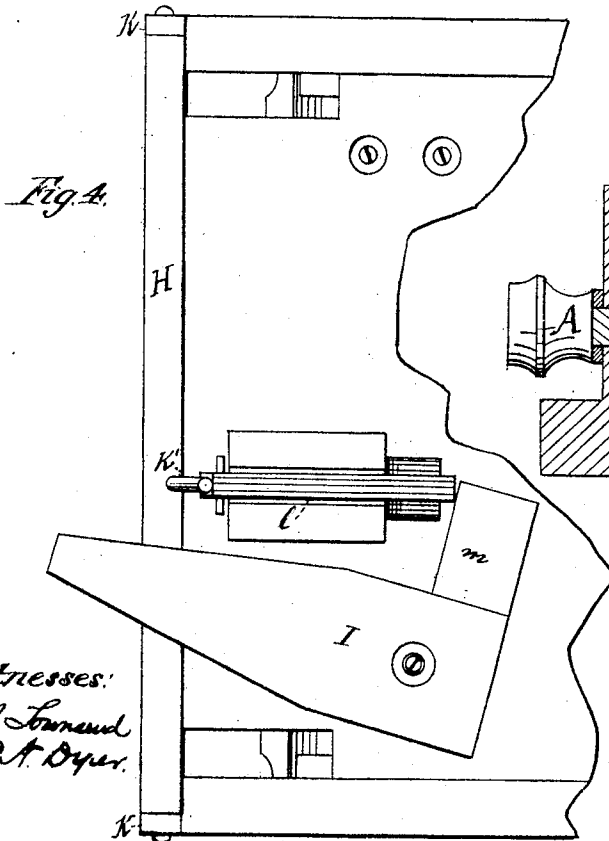
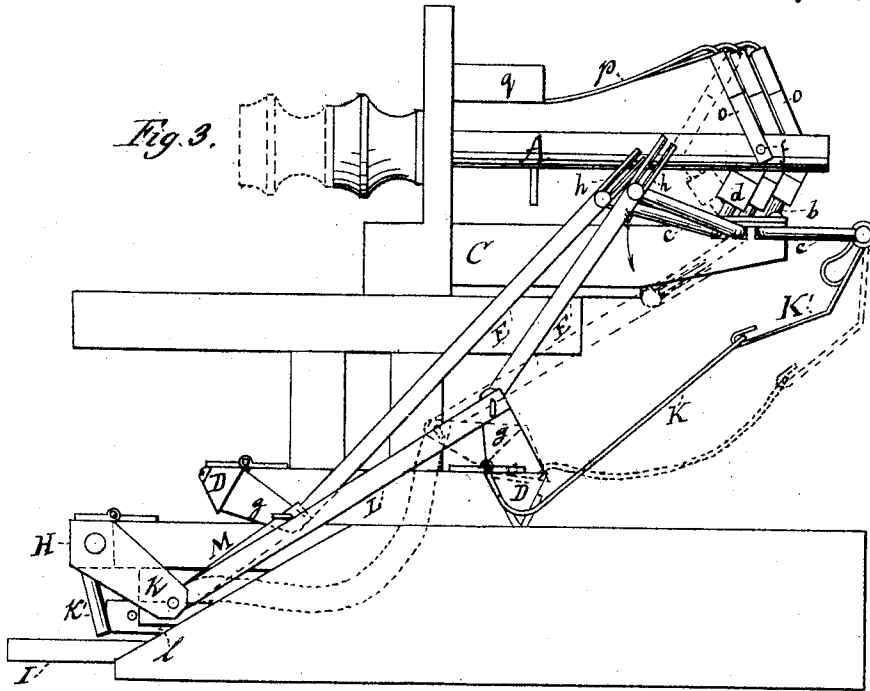

Witnesses:
F. B. Lunsford
Rich. A. Dyer.

Inventor:
John A. Smith
per Wm. H. Lotz
Attorney.

UNITED STATES PATENT OFFICE.

JOHN A. SMITH, OF CHICAGO, ILLINOIS.

REED-ORGAN STOP-ACTION.

SPECIFICATION forming part of Letters Patent No. 241,740, dated May 17, 1881.

Application filed January 31, 1880.

To all whom it may concern:

Be it known that I, JOHN A. SMITH, of Chicago, in the county of Cook and State of Illinois, have invented certain new and useful Improvements in Stop-Actions for Reed-Organs, of which the following is a specification.

The object I have in view is to produce a stop-action for reed-organs which will include a cheap, simple, and effective method of operating the stop-valves or mutes and retaining them in an open position; simple means for connecting the grand-organ lever with all the mutes in a more direct manner than heretofore; a cheap and noiseless pivotal connection between the stop-drawers and crank-shafts, so as to do away with the additional board for guiding such stop-drawers and preventing them from twisting; a device for assuring the full and complete movement of the stop-drawers in either direction every time they are operated, and a simple, strong, and compact construction of all the parts of the stop-action.

My invention therein consists in the several combinations of the parts for accomplishing these objects, as fully hereinafter explained, and pointed out by the claims.

In the accompanying drawings, forming a part hereof, Figure 1 is a top view of the stop-action with the mutes closed; Fig. 2, an elevation from one end or side of the same; Fig. 3, an elevation of the opposite end, one mute being shown as open in dotted lines; Fig. 4, a bottom view, showing the knee-lever for operating the grand organ; and Fig. 5, a sectional view through one of the stop-drawers and its spring-toggle connection with the crank-shaft.

Like letters denote corresponding parts in all the figures of the drawings.

A represents the stop-drawers, of usual construction, which are connected at their inner ends to wire crank-shafts B, laid in grooves *a* in the supporting-board C, and held by cross-pieces secured to such board. These wire shafts have their inner ends bent at right angles to form cranks *b*, by which they are turned from the stop-drawers, and their outer ends bent to form cranks *c*, for connecting with the stop-valves or mutes. The cranks *b* are rigidly and positively connected to the shanks of the stop-drawers by small wooden blocks *d*, which have tongues *d'*, entering grooves *e* on the under side

of the stop-drawers, and pivoted in such grooves by transverse pins *f*. Each block is first bored with a round hole, *d*², slightly smaller than the end of the wire, and is then forced onto the crank *b*, where it will be held by the spring and friction of the wood. These blocks are made of maple or other tough wood, so that they will not split. The wood blocks *d* form a positive and noiseless connection between the crank-shafts and the stop-drawers, guiding such stop-drawers and preventing them from twisting, and the necessity of using an additional guiding frame or board is done away with.

D are the stop-valves or mutes, of the usual construction, and kept closed by springs, as heretofore. Each mute has an arm, *g*, projecting from its outer end, to which is pivoted by a cross-pin the lower end of a flat wooden bar or rod, E. The arms *g* are so situated upon the mutes that by pushing upon them the mutes will be opened. The rods E have forked or open-slotted upper ends *h*, which inclose and slide upon studs on the ends of the crank-arms *c*. The cranks *c*, that are connected with the mutes by these wooden rods, are turned forward above the line of centers, so that the pulling out of the stops will throw such cranks downward, and pushing upon the said rods will raise the mutes and open the stops. When any stop is open the stud of the crank *c* which operates that mute will be thrown a short distance below the straight line of centers, as shown by dotted lines in Fig. 3, and the parts will be held in that position by the spring of the mute. The pushing in of the stop-drawer raises the pin of the crank-arm above the line of centers, and the mute is closed by its spring. This direct connection of the crank-shafts, which are turned by the stop-drawers, and the mutes, by means of crank-arms and push-rods, which are arranged to brace each other when the mutes are open, forms a device for operating the mutes by the use of a fewer number of parts and with less friction than heretofore. Thus it will be seen that a complete stop-action is formed without the use of the spring-toggle connections between the stop-drawers and crank-shafts, which will be presently described, or of any other device at that point to lock the mutes in an open position; but when such spring-

toggles are used the cranks and wood rods need only be brought into a straight line, although, for additional certainty, the cranks may be adjusted to throw the crank-pins in opening the stops slightly below the line of centers.

The slots *h* in the upper ends of the rods *E* are made long enough, so that when the stop-drawers are pushed in and the mutes are closed there will be a little room for play between the crank-pins and the bottoms of the slots, so that a slight disarrangement of the parts will not affect the closing of the mutes.

For opening all the mutes simultaneously, (operating the grand organ,) I connect the arm *g* of the mutes on each side of the organ by a flat wooden rod or bar, *F*, having slots *i*, through which slots the pins pass which pivot the rods *E* to the said arms *g*. These bars *F* have pivoted to them the upper ends of bars *G*, which extend downward and forward, and are connected to arms *k* on the ends of a hinged rock-bar, *H*, which is hinged to the upper front corner of the organ-action or wind-chest. This hinged bar *H* has an arm, *k'*, which projects downwardly from the same, near its center, and engages with the forward end of a sliding dove-tailed block, *l*, which slides in dove-tailed grooves formed by pieces secured to the under side of the bottom board of the wind-chest. A knee-lever, *I*, is pivoted to the said bottom board, and has at its rear end an arm, *m*, which strikes against the inner end of the block *l*. By swinging the knee-lever *I* the rock-bar *H* will be turned upwardly and the bars *G* drawn forward and downward, opening all the mutes. The mutes remain open as long as the lever *I* is pressed to one side by the knee; but as soon as the lever is relieved of this pressure the mutes will be closed by their own springs.

It will be seen that by reason of the slots *i* the arms *g* of the mutes will slide upon the rods *F* when the stop-drawers are operated, so that the mutes can be opened and closed independently of each other. This manner of connecting the grand-organ lever with all the mutes is very simple, strong, and durable, and enables the mutes to be operated without moving the crank-shafts, the forked ends of the rods *E* sliding upon the crank-pins.

If the organ has more than four stops, the grand-organ lever can be connected with any greater number of mutes by one or more additional slotted rods on each side and the necessary connections with the rock-bar.

For the purpose of throwing the stop-drawers the entire limit of their movement and for holding them positively in either position, I pivot to each stop-drawer, by the same pin that holds the block *d*, a forked block, *o*, having a socket in its upper end, in which sets the hooked end of a wire spring, *p*. The springs *p* are rigidly secured at their other ends under a cross-strip, *q*, so that they press down upon such forked blocks *o*. The blocks *d* and *o* and the springs *p* form spring toggle-joints, which throw the stop-drawers in both directions, so that after any stop-drawer has been pulled or pushed past the

center of its movement the spring toggle-joint will throw it with certainty the remaining distance.

As a substitute in cheap organs for the rigid push-rods *E*, for opening the mutes, I can use for each mute a flexible strap, *K*, Figs. 2 and 3, which can be connected to the under side of the mute, and to a spring-arm, *K'*, held by the crank-pin of one of the cranks *c*. In this construction the crank would be turned in the opposite direction, so as to pull upon the strap; and in place of the slotted rods *F* and the rods *G*, I can connect the arms *k* of the rock-bar *H* to the arms of the mutes by flexible straps *L*, *M*, Fig. 3, which would be a cheaper construction than that first explained and would answer the same purpose.

I am aware that reed-organs have been before provided with a grand-organ attachment for operating all the mutes simultaneously without affecting the stop-drawers or their crank-shafts, and without interfering with the independent operation of each mute by its stop-drawer.

What I claim as my invention is—

1. In a stop-action for reed-organs, the combination, with the stop-drawers, the crank-shafts, and the mutes, of the push-rods *E*, the slotted rods *F*, the rods *G*, and the rock-bar *H*, operated by the grand-organ lever, substantially as described and shown.

2. In a stop-action for reed-organs, the combination, with the mutes, of the rock-bar *H*, connected with the same, and having arm *k'*, the sliding block *l*, and the knee-lever *I*, having arm *m*, substantially as described and shown.

3. In a stop-action for reed-organs, the combination, with the mutes, of the cranks which are operated by the stop-drawers, and the push-rods connecting such mutes directly with the cranks, the parts being constructed as described, whereby the crank-pins will be thrown below the line of centers when the mutes are open, for the purpose of holding the mutes open, substantially as described and shown.

4. In a stop-action for reed-organs, the combination, with the mutes having arms, of the crank-shafts operated by the stop-drawers, and the push-rods pivoted to the arms on the mutes and connected directly to the cranks, all arranged as described, whereby the crank-pins are thrown past the line of centers when the mutes are opened, substantially as described and shown.

5. In a stop-action for reed-organs, the wire crank-shafts having both ends bent to form cranks, and the stop-drawers connected directly and positively to the cranks on the inner ends of such shafts, in combination with the mutes and the push-rods connecting the mutes directly with the cranks on the outer ends of the said shafts, all arranged as described, whereby the crank-pins are thrown past the line of centers when the mutes are opened, substantially as set forth and shown.

6. In a stop-action for reed-organs, the com-

5 combination, with the crank-shafts B, having cranks *b* at their inner ends, of the stop-drawers A, pivoted to the cranks *b* by means of wood blocks *d*, substantially as described and shown.

10 7. In a stop-action for reed-organs, the combination, with the crank-shafts and the stop-drawers, of the spring toggle-joints connecting the shanks of the stop-drawers with crank-shafts for throwing the stop-drawers to the extreme limit of their movement independently of the mute-springs, substantially as described and shown.

8. In a stop-action for reed-organs, the combination, with the crank-shafts and the stop-drawers, of the blocks *d* *o* and springs *p*, forming spring toggle-joints to throw the stop-drawers, substantially as described and shown. 15

JOHN A. SMITH.

Witnesses:

RICHD. N. DYER,
OLIVER W. MARBLE.