

No. 763,274.

PATENTED JUNE 21, 1904.

C. FOSTER.
SCAFFOLD.

APPLICATION FILED MAR. 18, 1903.

NO MODEL.

3 SHEETS—SHEET 1.

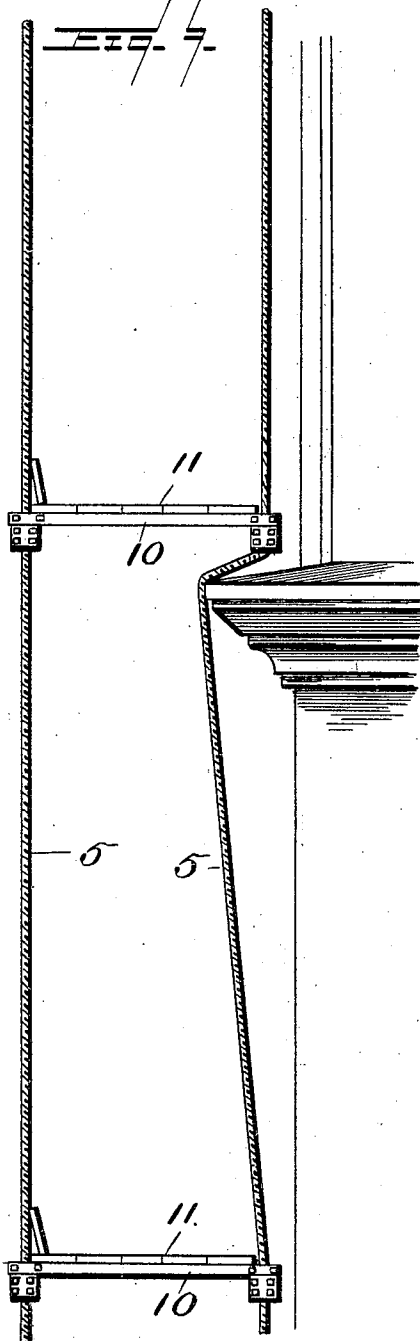
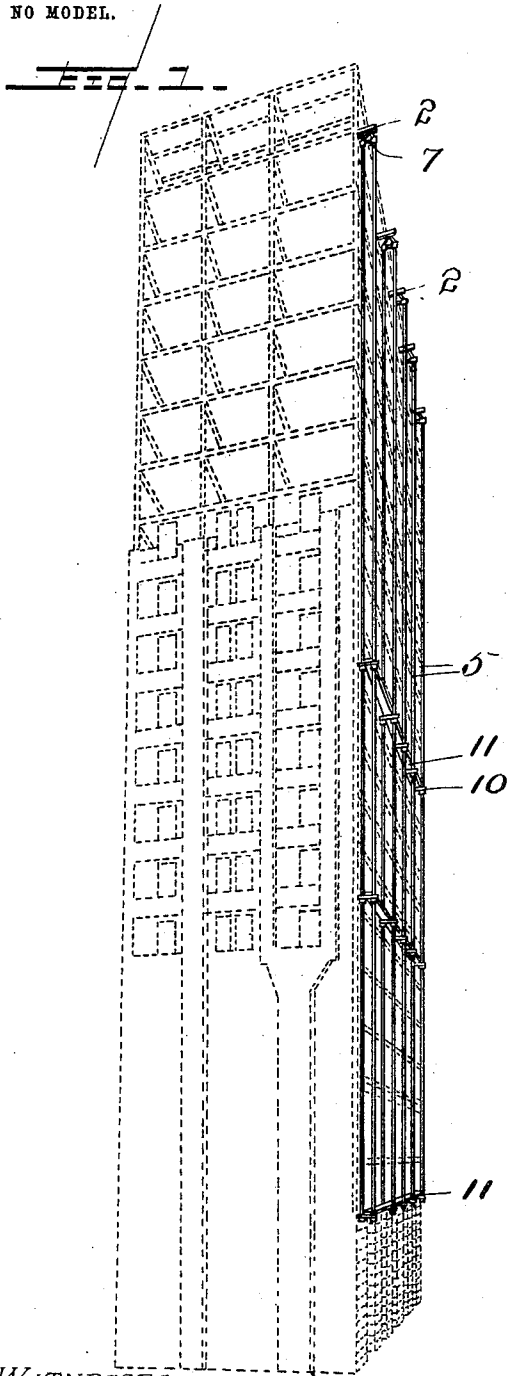

WITNESSES

Wm. F. Doyle.
Geo. B. Pitts.

INVENTOR

Clair Foster.

BY

J. S. Baskin
his Attorney

No. 763,274.

PATENTED JUNE 21, 1904.

C. FOSTER.
SCAFFOLD.

APPLICATION FILED MAR. 18, 1903.

NO MODEL.

3 SHEETS—SHEET 2.

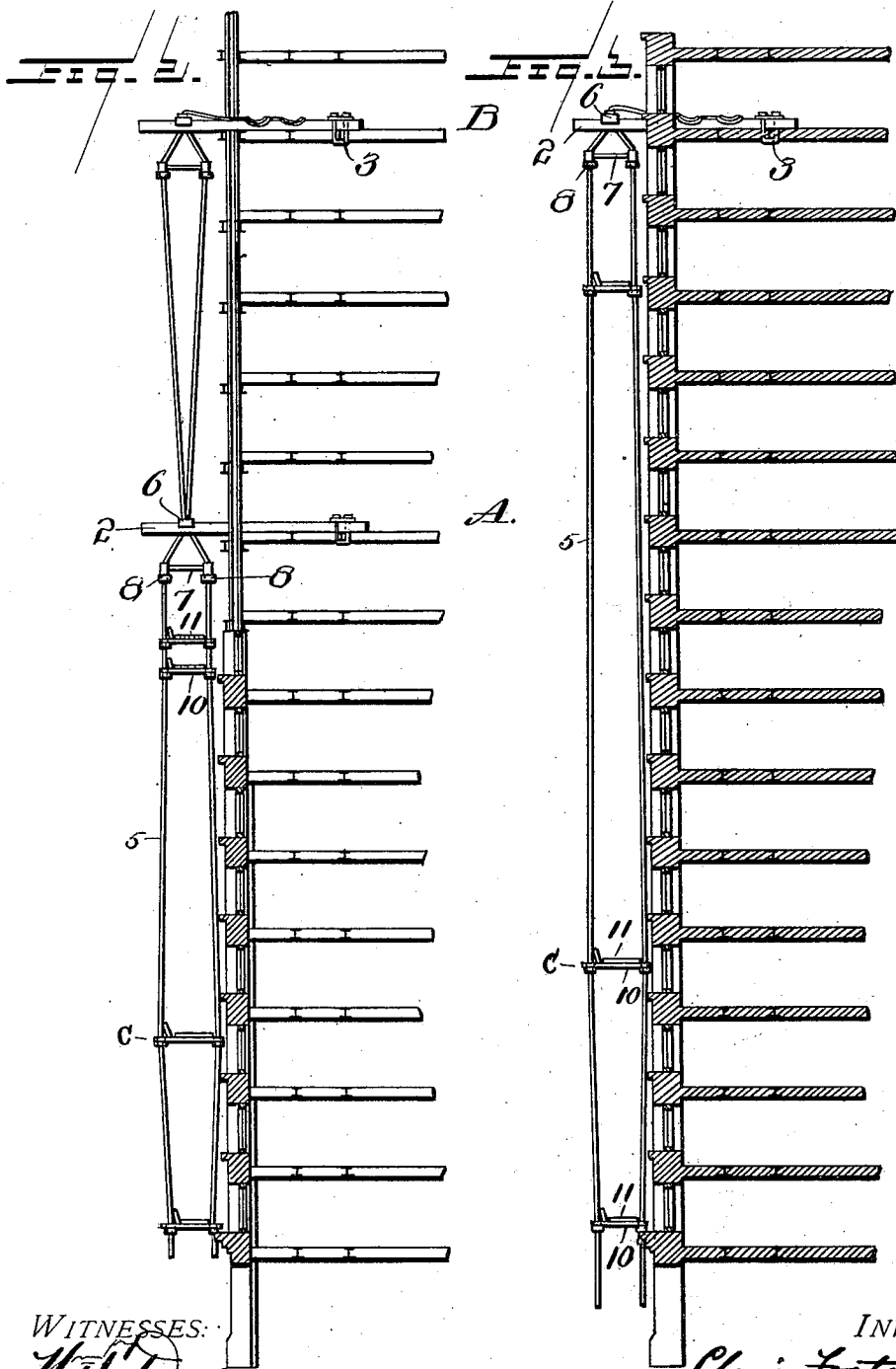

WITNESSES:
W. F. Doyle.
Geo. B. Pitts.

INVENTOR
Clair Foster
BY
J. S. Parker
Attorney

No. 763,274.

PATENTED JUNE 21, 1904.

C. FOSTER.
SCAFFOLD.

APPLICATION FILED MAR. 18, 1903.

NO MODEL.

3 SHEETS—SHEET 3.

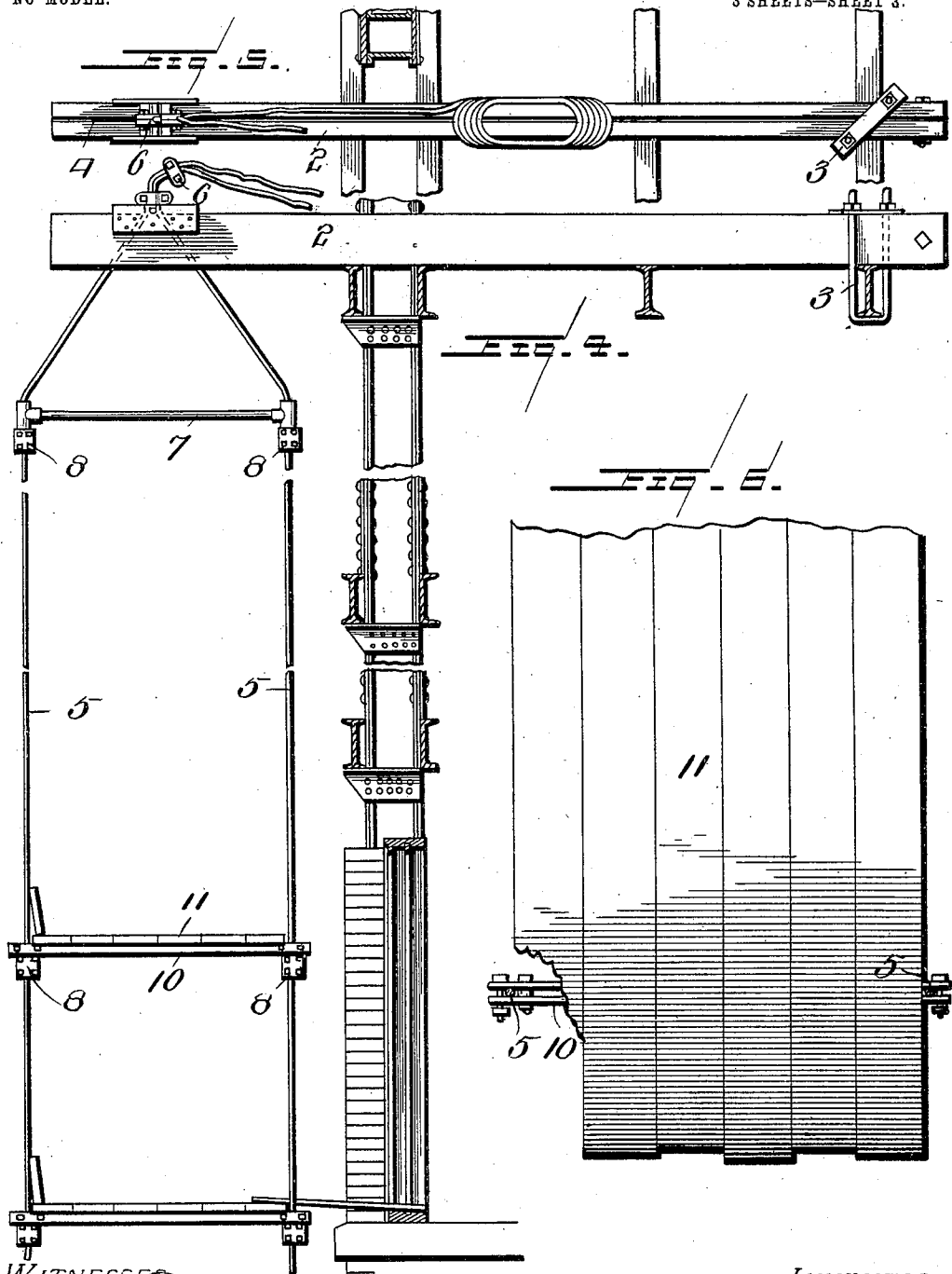

WITNESSES:

Wm. F. Doyle.
Geo. B. Pitts.

INVENTOR

Clair Foster

BY

J. S. Barker
his Attorney.

UNITED STATES PATENT OFFICE.

CLAIR FOSTER, OF DOUGLASTON, NEW YORK.

SCAFFOLD.

SPECIFICATION forming part of Letters Patent No. 763,274, dated June 21, 1904.

Application filed March 18, 1903. Serial No. 148,337. (No model.)

To all whom it may concern:

Be it known that I, CLAIR FOSTER, a citizen of the United States, residing at Douglaston, borough of Queens, in the county of Queens and State of New York, have invented a new and useful Scaffold, of which the following is a specification.

My invention relates to a mason's platform or scaffold, and has for its object to produce a scaffold that is particularly adapted for use in the construction of the modern steel-frame type of buildings of great height. In the construction of such buildings it is customary and often very desirable after the steel frame is erected to start the masonry at two or three different levels simultaneously, and heretofore it has been necessary when this is done to set up scaffolds for each part of the masonry construction.

One of the objects of my invention is to produce a scaffold the supports of which are of such character as to sustain and to be used for as many platforms as may be necessary and to so construct and set up such supports as to make it unnecessary to shift them during the entire construction of the building.

The invention has other advantages, which will be hereinafter set forth.

In the accompanying drawings, Figure 1 is a perspective view of a steel-frame building in the course of construction having my improvements in scaffolds applied thereto. Fig. 2 is a sectional elevation of a building in the course of construction with my invention applied thereto. Fig. 3 is a view similar to Fig. 2, showing the same building farther advanced toward completion, illustrating my invention. Fig. 4 is an enlarged side view showing my invention. Fig. 5 is a top plan view of the parts represented in Fig. 4. Fig. 6 is a horizontal sectional view taken immediately above one of the floorings, part of the latter being broken away. Fig. 7 is an elevation of a short section of the scaffold, illustrating how it may be carried past a projecting cornice of a building.

The scaffold in which my invention is embodied comprises a set of outriggers, a set of flexible platform-suspending means, preferably steel cables, carried by the outriggers,

and platforms suitably supported by and vertically adjustable upon the suspending-cables.

In the accompanying drawings, 2 2 designate outriggers. These may be of any usual or preferred construction. As shown, they consist of beams securely bolted to the steel-frame structure of the building, as by means of the clamps 3. These beams project out from the structure and at their outer ends are perforated, as at 4, for the passage of the steel cables 5 5. I prefer that the outriggers should be arranged as high up as is convenient. Ordinarily they will be arranged near the top of the steel-frame structure, though sometimes they may be arranged at a lower level, as is represented in Fig. 2, and this is particularly the case when it is desirable to begin the masonry - work before the steel frame is entirely erected.

As represented in the drawings, each of the outrigger-beams 2 supports a pair of steel cables 5, and the latter are preferably connected to each other above the outrigger by clamps 6. These hold the two cables together and rest upon the beam, operating, in conjunction with the outriggers, as supporting means for the cables. Additional means for uniting the cables to the outriggers and for suspending them may be used, if found desirable. The cables of each pair are held apart by a spacing-bar 7. This is preferably arranged close to the outrigger and is held in place by the clamps 8, secured, respectively, to the cables. The spacing-bar is preferably provided at its ends with eyes through which the cables pass and is free to be adjusted longitudinally of the cables. The cables are of a length to extend downward from the outriggers to or below the lowest level at which it may be desirable to support a platform.

10 10 represent the putlogs, upon which the flooring 11 rests and is supported. These putlogs may be of any usual or preferred construction; but I prefer that they should be adjustable vertically along the supporting-cables 5. They may be similar in construction to the spacing-bars 7, or they may be formed of two cross-bars arranged side by side, as shown in Fig. 6, bolted together, the cables being confined between the bars and bolts.

These putlogs may be adjusted with the utmost nicety, being held in place upon the cables by means of clamps 8, applied to the cables, upon which clamps the putlogs rest.

5 In Fig. 1 the scaffold is represented as being supported from outriggers arranged near the top of the steel-frame structure. Upon the cables suspended from the outriggers are represented three platforms—one opposite the
10 third story, another opposite the eighth story, and a third opposite the twelfth story. It will be observed that these three platforms are all supported from the same cables and also that each platform is quite independent of the
15 others and may be adjusted up or down without reference to the other platforms, or any platform may be entirely removed without interfering with the others.

In Fig. 2 I have illustrated an advantage that is incident to my invention and which is quite novel in the art. As already stated, it is sometimes desirable to rig the scaffold before the steel frame of the building is entirely erected, and in this figure it is represented
25 that this has been done, the outriggers at A being located at the eleventh floor of a sixteen-story structure. This permits the masonry-work to be started at any of the floors below the eleventh while the upper part of
30 the steel structure is being completed. When this is done, the cables are connected with the outriggers at A at points intermediate their length, sufficient of the cable being reserved to extend to the top of the structure, and this
35 is coiled up, as represented in Figs. 2, 3, and 5. When the frame structure is completed, the portions of the cables above the outriggers A are carried up and secured to a set of
40 outriggers near the top of the frame, as indicated at B. This can be done without interfering with the supports for the cables at A and without interfering in any wise with the use of the scaffold. After the cables are properly
45 secured to the outriggers at the level B they are preferably released from the outriggers at the level A, and these are entirely removed, as indicated in Fig. 3.

In Fig. 7 I have represented how a scaffold made according to my invention may be carried
50 past a cornice projecting out so far beyond the face of the building as to be in the way of the inner cables 5. By reason of the flexibility of the cables and of the putlogs being mounted freely thereupon one set of the
55 cables may be deflected to pass the obstruction without destroying the continuity of the scaffold, while the platforms both above and below such deflection may be adjusted and arranged as desired.

60 After the masonry-work has been completed and the outside of the structure is practically finished it is necessary to clean and point up the work. It has heretofore been necessary to rig a special scaffold for the work-
65 men employed for this purpose. In using my

invention, however, this is not required, as the cables are left after the masonry-work is completed and may be used to support the
platforms on which the workmen who do this finishing-work stand. 70

I am aware that platforms for workmen have been suspended by flexible cables from the roofs or upper portions of structures; but heretofore, so far as I am aware, in such cases
ropes have been employed for this purpose 75 and the platforms were adjusted by block-and-tackle contrivances about which the ropes pass. This has rendered it impossible to support more than a single platform from one set of suspending-cables. I am also aware that
80 it has been proposed to support a plurality of platforms for masons' use upon metal bars suspended from outriggers; but it will be readily understood that such a scaffold must necessarily be quite limited in size, both on
85 account of the impracticability of using excessively-long metal bars and because of the great weight which would be incident to a scaffold of this kind arranged to extend to more than three or four stories in vertical
90 dimensions.

I believe that I am the first to devise a continuous scaffold that may be extended upward above the point of support to a higher support, also to devise a scaffold having flexible
95 suspending means upon which may be supported a plurality of platforms independently adjustable, and also to have combined the suspending-cables, putlogs for the flooring of the platforms, and rope or cable clamps adjustable
100 upon the cables for supporting the putlogs.

If it be found desirable at any time to use a platform of unusual width, this is quite feasible, as represented in Figs. 2 and 3 at C. 105

Having described my invention, what I claim, and desire to secure by Letters Patent, is—

1. In a scaffold, the combination of a set of outriggers, supporting-cables suspended
110 therefrom, putlogs adjustable vertically along the said cables, and clamps arranged to be secured to the cables upon which the putlogs rest, substantially as set forth.

2. In a scaffold, the combination of a set
115 of flexible cables, platforms supported thereby, outriggers from which the cables are suspended, and means for making the cables fast to the said outriggers at points between their
120 ends, the upper portions of the cables extending beyond the outriggers, whereby such portions are arranged to be continued upward and suitably supported without interfering with the platforms below such outriggers, substantially as set forth. 125

3. In a scaffold, the combination of a series of outriggers, a series of flexible cables rigidly connected to and suspended from the
outriggers, spacing-bars for holding the cables
apart, adjustable clamps adapted to be secured 130

to the cables, putlogs resting upon said clamps, and flooring supported on the putlogs, substantially as set forth.

4. In a scaffold, the combination of a series
5 of outriggers, a series of pairs of cables supported therefrom, means for connecting the cables of each pair to each other and to their supporting-outrigger, means for holding the cables apart, putlogs adjustably connected
10 with the cables, and the platforms resting on the putlogs.

5. In a scaffold, the combination of a set

of outriggers, flexible supporting means suspended therefrom, and flooring connected with the flexible supporting means between 15 the lower ends thereof and the outriggers, the flexibility of the suspending means permitting them to be deflected at points intermediate their upper and lower ends without destroying their continuity, substantially as set forth. 20

CLAIR FOSTER.

Witnesses:

A. MCGONAGLE,
L. J. MORTON.