



US 20090133850A1

(19) **United States**

(12) **Patent Application Publication**  
**KELLY et al.**

(10) **Pub. No.: US 2009/0133850 A1**

(43) **Pub. Date: May 28, 2009**

(54) **SYSTEMS FOR CENTRIFUGALLY CASTING  
HIGHLY REACTIVE TITANIUM METALS**

**Publication Classification**

(75) Inventors: **THOMAS JOSEPH KELLY,**  
Cincinnati, OH (US); **Michael**  
**James Weimer,** Loveland, OH (US)

(51) **Int. Cl.**  
**B22D 13/00** (2006.01)  
(52) **U.S. Cl.** ..... **164/286**  
(57) **ABSTRACT**

Correspondence Address:  
**GENERAL ELECTRIC COMPANY**  
**GE AVIATION, ONE NEUMANN WAY MD H17**  
**CINCINNATI, OH 45215 (US)**

Systems for centrifugally casting a highly reactive titanium metal including a cold wall induction crucible for containing a titanium metal charge, the induction crucible having a plurality of induction coils and a removable bottom plate, a power source to heat the titanium metal charge in the induction crucible to obtain a molten metal, a preheated secondary crucible for catching the molten metal as it falls from the induction crucible after the removable bottom plate has been withdrawn and the power source turned off, and a centrifugal casting machine for holding and accelerating the secondary crucible to centrifugally force the molten metal into a casting mold and produce a cast component.

(73) Assignee: **GENERAL ELECTRIC  
COMPANY**

(21) Appl. No.: **11/945,388**

(22) Filed: **Nov. 27, 2007**

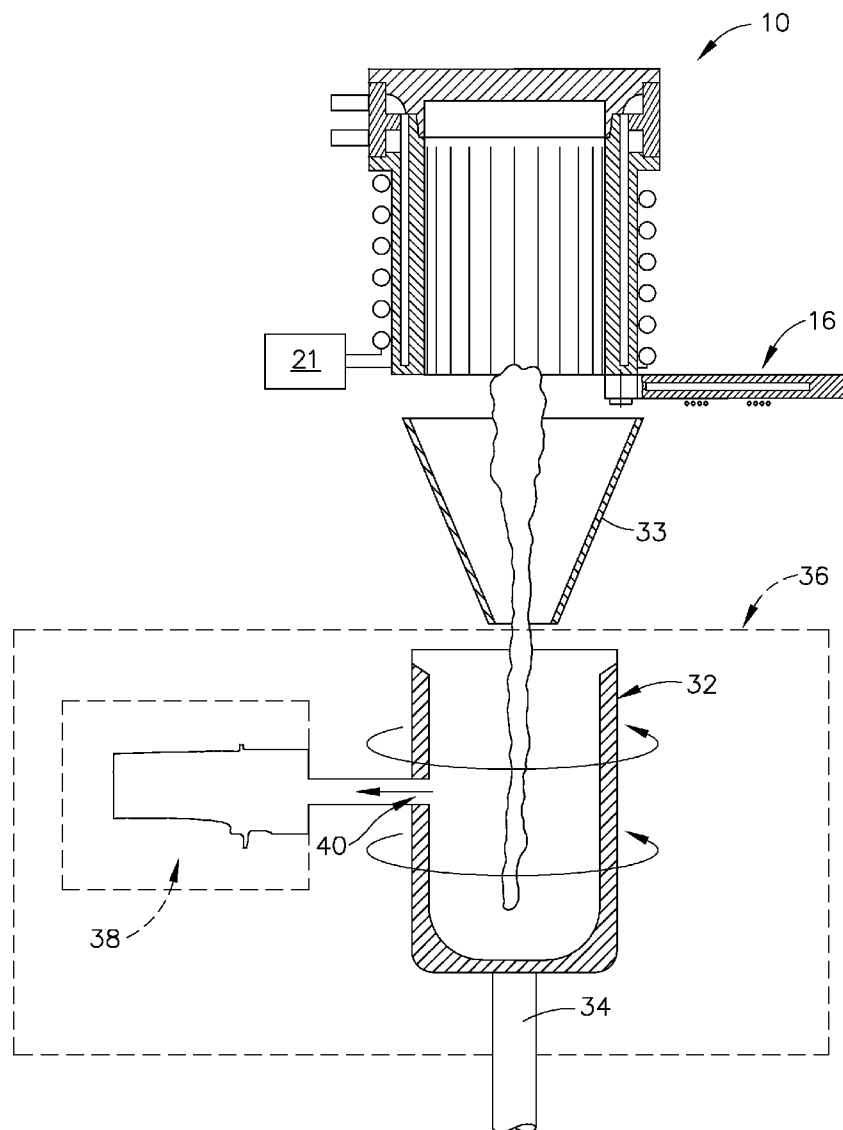

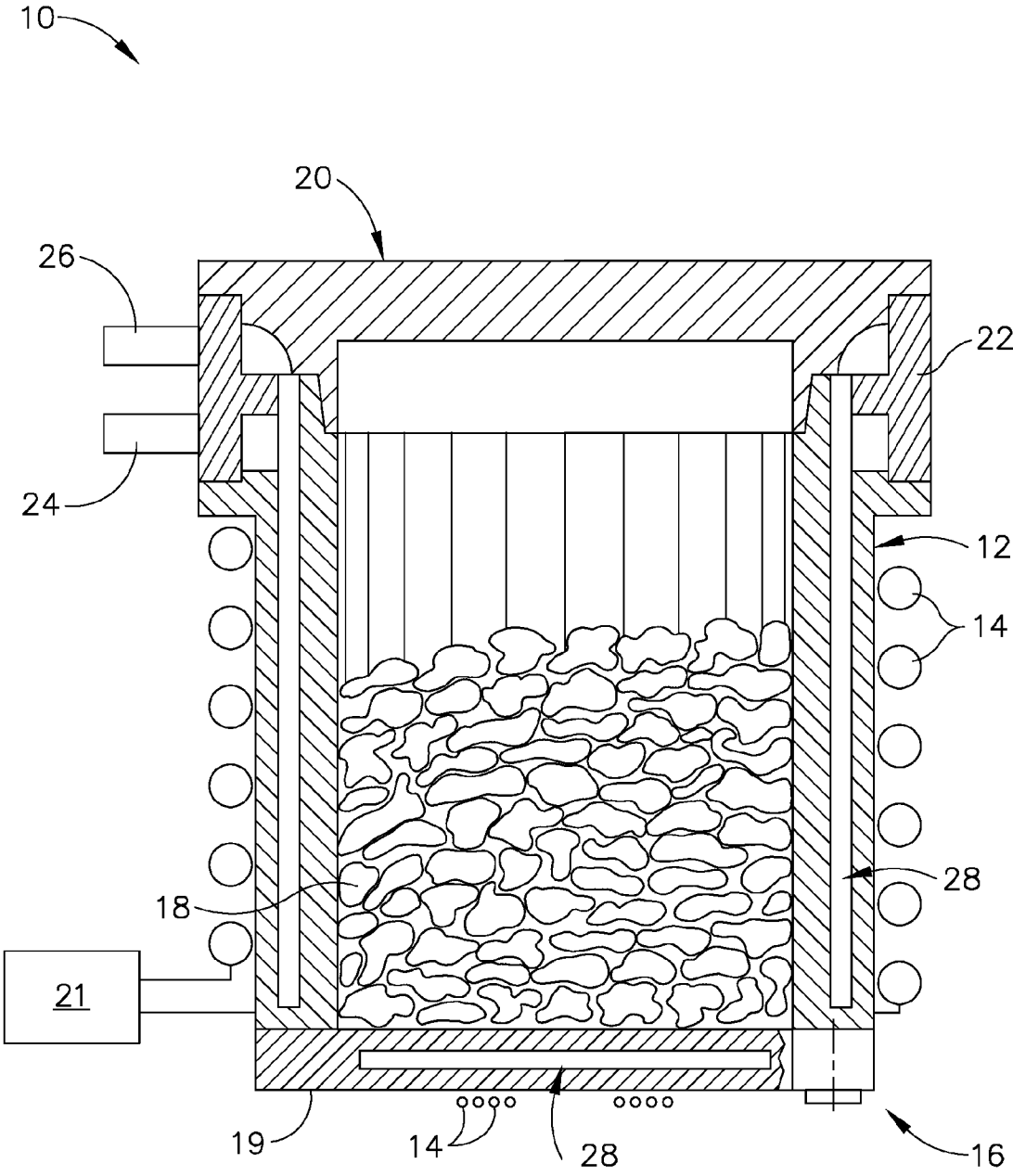

FIG. 1

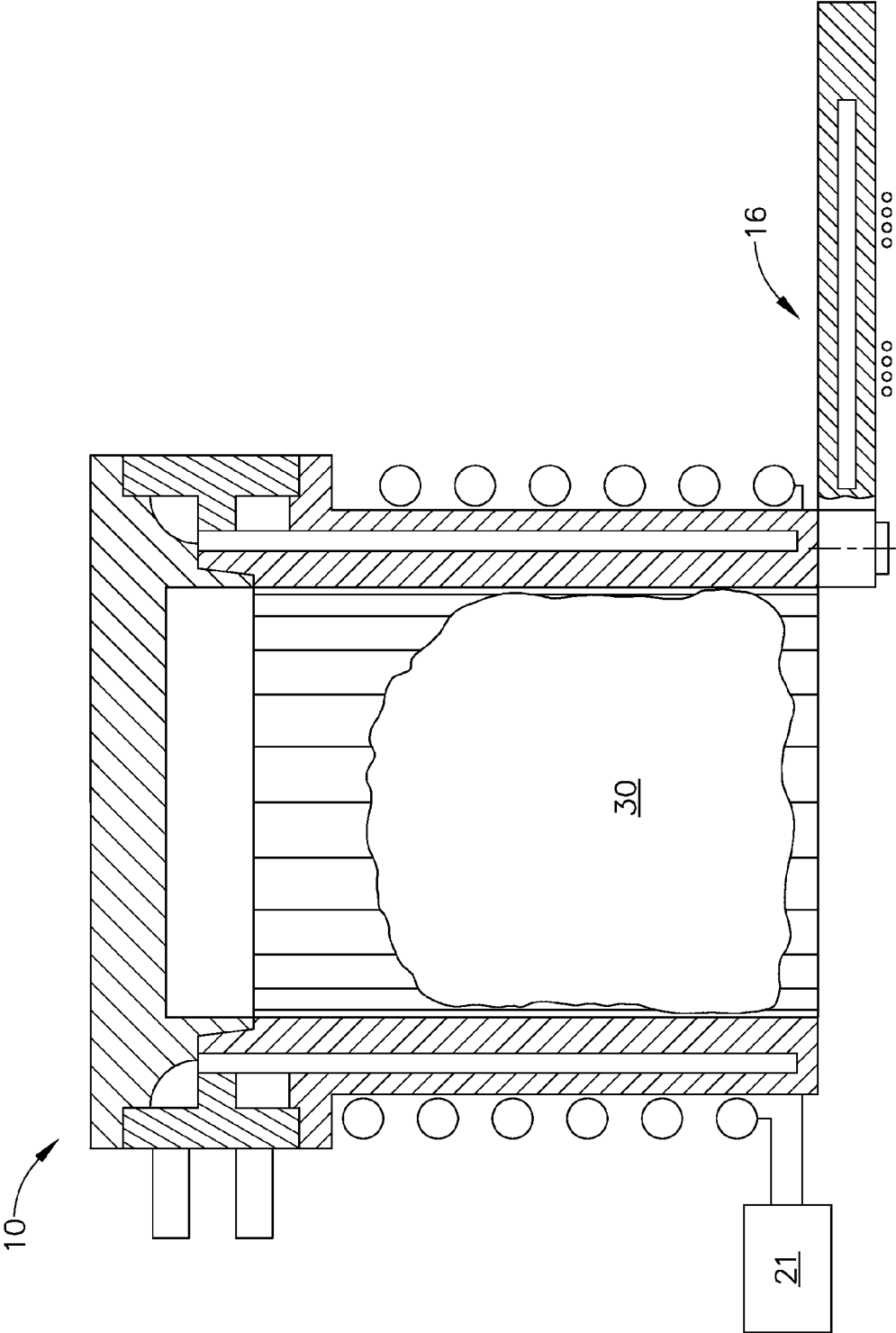

FIG. 2

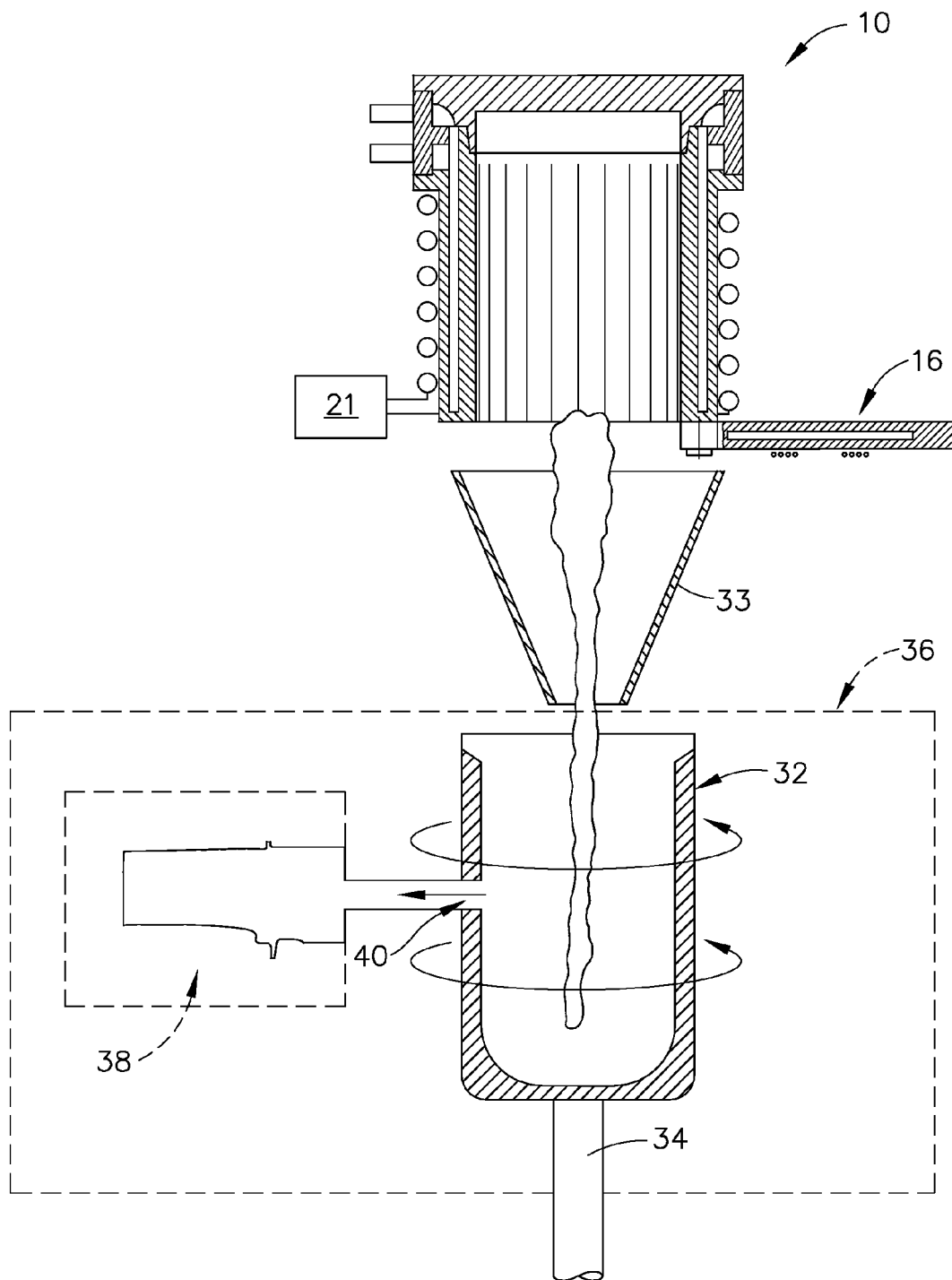

FIG. 3

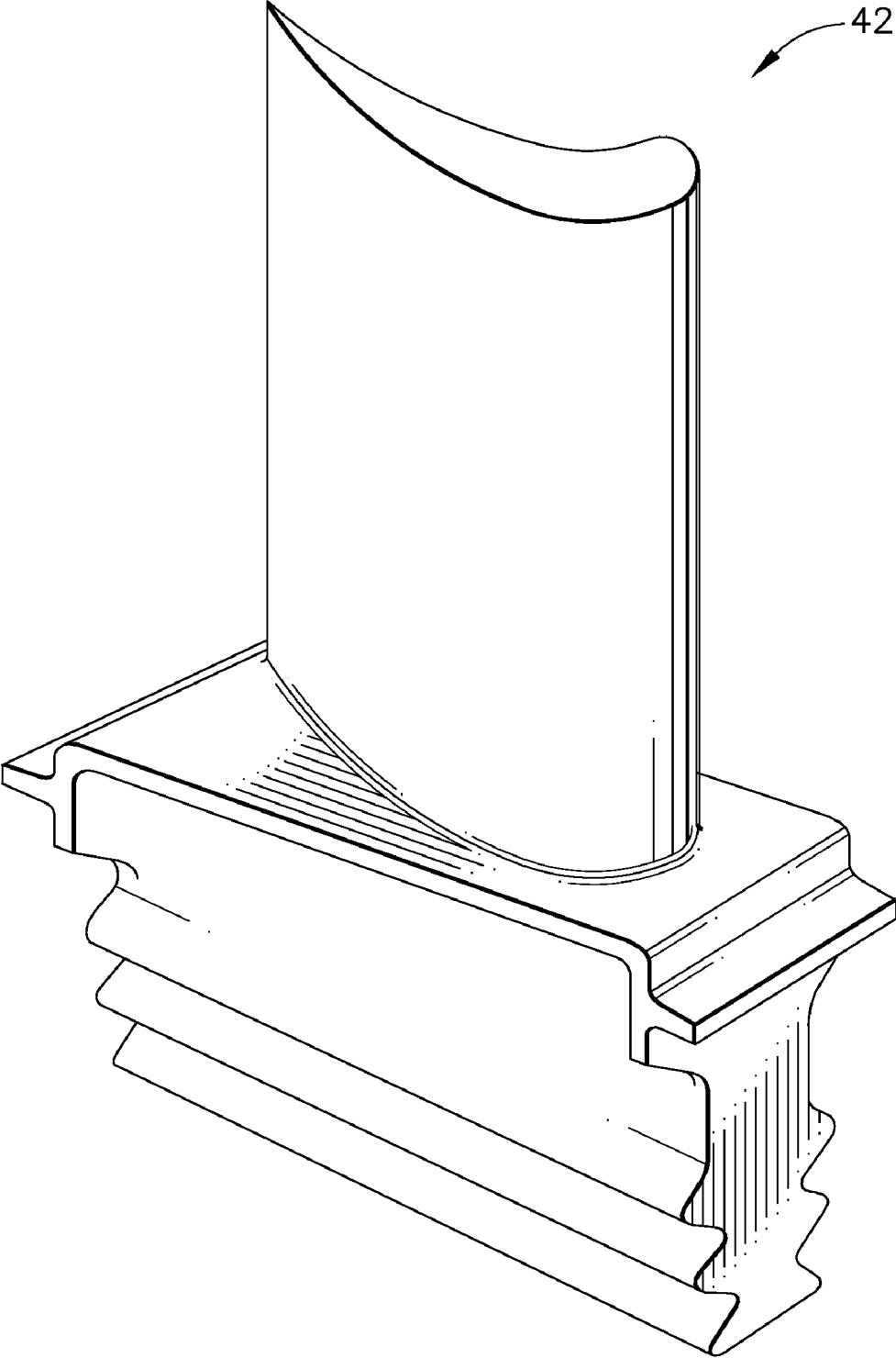

FIG. 4

## SYSTEMS FOR CENTRIFUGALLY CASTING HIGHLY REACTIVE TITANIUM METALS

### TECHNICAL FIELD

[0001] Embodiments described herein generally relate to systems for centrifugally casting highly reactive metals. More particularly, embodiments herein generally describe systems for centrifugally casting highly reactive titanium alloys, and in particular, titanium aluminide alloys.

### BACKGROUND OF THE INVENTION

[0002] Turbine engine designers are continuously looking for new materials with improved properties for reducing engine weight and obtaining higher engine operating temperatures. Titanium alloys (Ti alloys), and in particular, titanium aluminide based alloys (TiAl alloys), possess a promising combination of low-temperature mechanical properties, such as room temperature ductility and toughness, as well as high intermediate temperature strength and creep resistance. For these reasons, TiAl alloys have the potential to replace nickel-based superalloys, which are currently used to make numerous turbine engine components.

[0003] Vacuum Arc Re-melting (VAR) is one technique commonly used to melt Ti alloys. VAR generally involves striking an arc between a titanium alloy electrode and pieces of the same alloy (electrode ends, for example) placed in a water-cooled copper crucible. A molten pool is established and the electrode progressively melts. When sufficient molten metal is available, the electrode can be withdrawn and the crucible tilted to pour the metal into a mold for casting components.

[0004] The VAR technique can have several drawbacks. Titanium electrodes used in the VAR process can be expensive because of the high cost of titanium billets/forgings, and the high cost of labor involved in creating an electrode from certified scrap or revert material. Also, the requirement for a pre-alloyed electrode can make it difficult and expensive to produce non-standard alloys. Furthermore, the need to use a water-cooled crucible can limit the degree of superheat achievable in the metal, which in turn can affect fluidity, leading to difficulty in filling thin-wall castings. Moreover, the highest temperature exists where the arc strikes the metal, and high temperature gradients exist in the molten metal. This can also affect the filling of molds and sets up poor temperature gradients in the solidifying casting.

[0005] In view of the previously described issues with VAR techniques, another method that can be employed when melting Ti alloys is Vacuum Induction Melting (VIM). VIM was developed for processing specialized and exotic alloys that contain reactive elements, such as titanium and aluminum, which cannot be melted and cast in air. As the use of such alloys continues to increase, VIM is consequently becoming more commonplace.

[0006] Vacuum induction melting generally involves heating a metal in a crucible made from a non-conductive refractory alloy oxide until the charge of metal within the crucible is melted down to liquid form. In this technique, pieces of solid titanium alloy are placed in a cooled metal hearth, usually made of copper, and melted in an inert atmosphere using a very intense heat source, such as an arc or plasma. A molten pool will form initially on the interior and top surface of the charge of titanium while the titanium adjacent to the confining wall of the copper hearth remains solid. This

“skull” of solid titanium that develops contains the liquid titanium metal free of contamination. See U.S. Pat. No. 4,654,858, issued to Rowe for a general discussion of cold wall induction melting.

[0007] As referenced previously, copper crucibles are most often employed in cold wall induction melting of highly reactive alloys for a number of reasons. For example, melting and casting from ceramic crucibles can introduce significant thermal stress on the crucible, which can result in the crucible cracking. Such cracking can reduce crucible life and cause inclusions in the component being cast. Moreover, the highly reactive TiAl alloys can break down the ceramic crucible and contaminate the titanium alloy with both oxygen and the refractory alloy from the oxide. Similarly, if graphite crucibles are employed, the titanium aluminide can dissolve large quantities of carbon from the crucible into the titanium alloy, thereby resulting in contamination. Such contamination can result in a loss of mechanical properties of the titanium alloy. Copper is less likely to exhibit the previously described problems associated with ceramic and graphite crucibles, which is why copper crucibles are typically employed when using cold wall induction melting to melt highly reactive metal alloys.

[0008] However, while cold crucible melting in copper crucibles can offer metallurgical advantages for the processing of the highly reactive alloys described previously, it can also have a number of technical and economic limitations including low superheat, yield losses due to skull formation and high power requirements. In particular, the cold wall induction crucible suffers heat loss when the power to the crucible is terminated and the metal is allowed to slump against the water-cooled copper sides of the mold.

[0009] One development that has been employed to address the previously described issues with vacuum induction melting is bottom pouring from a cold hearth melting system through a nozzle. See U.S. Pat. No. 4,546,858 issued to Rowe and U.S. Pat. No. 5,164,097 issued to Wang et al. The nozzle material typically employed has been copper or brass, which are considered good thermal conducting materials. Graphite and thermally insulating materials have also been mentioned for use as nozzle material.

[0010] While the use of nozzles can provide many benefits over other common practices, the use of nozzles is not entirely without the potential for complications. For example, cold hearth melting and bottom pouring of reactive metals like titanium can result in undesirable melt freeze-off in the nozzle. In addition, many crucible/nozzle systems can struggle to provide the requisite control of liquid flow rate, minimize erosion of the nozzle, and minimize melt contamination.

[0011] Another development that has been employed to address the previously described issues with vacuum induction melting is levitation melting, which generally involves using energy from induction coils to electromagnetically suspend the metal being melted. See U.S. Pat. No. 5,275,229, issued to Fishman et al. for a general discussion of levitation melting. However, while the magnetic induction field can both heat the metal and hold the molten metal suspended in space within the crucible, once the power source for the system is turned off, the metal can slip back into the water-cooled crucible and chill again before it can be poured. This can result in incomplete filling of the mold.

[0012] Therefore, in spite of such advances, there remains a need for improved systems useful for melting highly reactive

metal alloys, such as TiAl, that allow the alloy to remain molten during pouring, yet reduces the occurrence of the issues associated with conventional melting processes.

#### BRIEF DESCRIPTION OF THE INVENTION

**[0013]** Embodiments herein generally relate to systems for centrifugally casting a highly reactive titanium metal comprising a cold wall induction crucible for containing a titanium metal charge, the induction crucible having a plurality of induction coils and a removable bottom plate, a power source to heat the titanium metal charge in the induction crucible to obtain a molten metal, a preheated secondary crucible for catching the molten metal as it falls from the induction crucible after the removable bottom plate has been withdrawn and the power source turned off, and a centrifugal casting machine for holding and accelerating the secondary crucible to centrifugally force the molten metal into a casting mold and produce a cast component.

**[0014]** Embodiments herein also generally relate to systems for centrifugally casting a highly reactive titanium metal comprising a cold wall induction crucible for containing a titanium metal charge, the induction crucible having a plurality of induction coils and a removable bottom plate, a power source to heat the titanium metal charge in the induction crucible to obtain a molten metal, a preheated secondary crucible for catching the molten metal as it falls from the induction crucible after the removable bottom plate has been withdrawn and the power source turned off, a funnel for transferring the molten metal from the induction crucible to the secondary crucible, and a centrifugal casting machine for holding and accelerating the secondary crucible to centrifugally force the molten metal into a casting mold and produce a cast component.

**[0015]** Embodiments also generally relate to systems for centrifugally casting a highly reactive titanium metal comprising a cold wall induction crucible for containing a titanium aluminide charge, the induction crucible having a plurality of induction coils and a slidably removable bottom plate, a power source to heat the titanium aluminide charge in the induction crucible to obtain a molten titanium aluminide, a preheated secondary crucible for catching the molten titanium aluminide as it falls from the induction crucible after the removable bottom plate has been withdrawn and the power source turned off, a niobium funnel for transferring the molten titanium aluminide from the induction crucible to the secondary crucible, and a centrifugal casting machine for holding the secondary crucible stationary for from about 0.5 to about 2 seconds after the molten titanium aluminide falls into the secondary crucible and, thereafter, accelerating the secondary crucible to from about 100 rpm to about 600 rpm within from about 1 second to about 2 seconds to centrifugally force the molten titanium aluminide into a casting mold and produce a cast component.

**[0016]** These and other features, aspects and advantages will become evident to those skilled in the art from the following disclosure.

#### BRIEF DESCRIPTION OF THE DRAWINGS

**[0017]** FIG. 1 is a schematic cross-sectional view of one embodiment of a cold wall induction crucible having a metal charge placed therein in accordance with the description herein;

**[0018]** FIG. 2 is a schematic cross-sectional view of one embodiment of a cold wall induction crucible having the bottom plate removed and the molten metal suspended therein in accordance with the description herein;

**[0019]** FIG. 3 is a schematic cross-sectional view of one embodiment of a centrifugal casting system in accordance with the description herein; and

**[0020]** FIG. 4 is a schematic perspective view of one embodiment of a component, a low pressure turbine blade, which can be cast in accordance with the description herein.

#### DETAILED DESCRIPTION OF THE INVENTION

**[0021]** Embodiments described herein generally relate to systems for centrifugally casting highly reactive metals, and in particular titanium alloys and titanium aluminide alloys, into net shape components, though the description that follows should not be limited to such.

**[0022]** In accordance with the description herein below, a cold wall induction crucible 10 having a body 12, can be provided, as shown in FIG. 1. Body 12 can be made from any metal having good thermal and electrical conductivity, such as, for example copper. Body 12 may be water-cooled to prevent the copper from melting during the heating of the crucible. More particularly, copper generally melts at about 1900° F. (about 1038° C.) and TiAl melts at about 2600° F. (about 1427° C.), and the copper in the crucible can form a low melting eutectic with the titanium. Water-cooling the crucible can prevent this from occurring. Water-cooling inlet 24 and outlet 26 may be used to circulate the cooling water through a plurality of channels 28 positioned about body 12. While body 12 may have any shape desired and acceptable for use in induction melting, in one embodiment, body 12 may be generally shaped as a hollow cylinder. Body 12 may have a plurality of induction coils 14 positioned thereabout, which can be heated using a power source 21. Coils 14 can serve as a heat source to melt a metal charge placed within the crucible and maintain its molten state, as described herein below.

**[0023]** Crucible 10 may also have a removable bottom plate 16 as shown in FIG. 1. Like crucible 10, bottom plate 16 may comprise any metal having good thermal and electrical conductivity, and in one embodiment, may comprise copper. Bottom plate 16 may also be water-cooled and have a plurality of induction coils 14 positioned thereunder, again, to help melt the metal charge placed with crucible 10 and maintain its molten state. Additionally, an electric insulator plate 19 may circumscribe bottom plate 16 to help maintain heat in the bottom of crucible 10. As described herein below, bottom plate 16 may be removed from body 12 in a variety of manners, including, but not limited to, sliding (as shown in FIGS. 2 and 3), rotating, dropping and the like.

**[0024]** In use, a metal charge 18 comprising a highly reactive alloy may be placed inside body 12 of crucible 10 as shown in FIG. 1. In one embodiment, metal charge 18 may comprise a titanium alloy, and more specifically a titanium aluminide alloy, and may take any acceptable form, which may include, but should not be limited to, lumps, ingots, granules, plates, powders, and mixtures thereof. Those skilled in the art will understand that the amount of metal charge 18 placed into crucible 10 can vary depending on intended use, however, in one embodiment, from about 1 pound (about 454 grams) to about 3.5 pounds (about 1588 grams), and in another embodiment from about 1.25 pounds (about 567 grams) to about 3.3 pounds (about 1497 grams) of metal

charge **18** can be used to make net shaped low-pressure turbine blades as described herein below.

**[0025]** Once metal charge **18** is placed inside crucible **10**, a cover **20**, which in one embodiment, may be made from the same material as crucible **10**, may be positioned on top of body **12** and held in place with a cover ring **22**, to ensure crucible **10** is sealed. Power source **21** may be turned on and metal charge **18** can melt when the appropriate temperature is attained, which in one embodiment may be from about 2700° F. to about 2835° F. (about 1480° C. to about 1557° C.). Those skilled in the art will understand that the electromagnetic field generated by the induction coils causes the metal charge to heat itself internally due to resistance heating caused by current flow within the metal charge. As metal charge **18** begins to melt, the resulting molten metal **30** may become suspended within body **12** of crucible **10** such that molten metal **30** does not come into contact with the inside of body **12** as long as the power is being supplied to crucible **10**. This suspension of molten metal **30** can prevent the formation of a skull.

**[0026]** Concurrent with melting the metal charge in induction crucible **10**, a secondary crucible **32**, or other like holding device, may be preheated using any acceptable means, such as, but not limited to, microwave or radiant energy. Secondary crucible may be made from graphite or ceramic, and may optionally have a metal liner, such as for example, niobium. Secondary crucible **32** can aid in the transfer of the molten metal to a casting mold without losing any of the superheat in the molten metal generated during induction melting in the induction crucible **10**. More specifically, secondary crucible **32** can be preheated to at least about 1832° F. (about 1000° C.), and in one embodiment from about 1832° F. to about 2200° F. (1000° C. to about 1200° C.), when secondary crucible **32** comprises niobium, and to at least about 1980° F. (about 1082° C.), and in one embodiment from about 1980° F. to about 2400° F. (1082° C. to about 1316° C.), when secondary crucible comprises ceramic. Preheating can help prevent thermal shock and cracking of secondary crucible **32**, which would allow for reuse thereof. Preheated secondary crucible **32** may then be placed in the rotating arm **34** of a centrifugal casting machine **36** and positioned below induction crucible **10**, as shown generally in FIG. 3. Any conventional centrifugal casting machine is acceptable for use herein, such as for example, the Linn High-Therm Titancast 700 (Germany) or the SEIT Supercast (Italy).

**[0027]** Removable bottom plate **16** may then be withdrawn from body **12** of crucible **10**, as previously described. In the embodiments shown in FIGS. 2 and 3, bottom plate **16** may be slidably removed from crucible **10** using any acceptable mechanism, such as, but not limited to, tracks or guides. Although bottom plate **16** is removed, the electromagnetic field generated by induction coils **14** can maintain molten metal **30** in a suspended state within body **12** of crucible **10** as shown in FIG. 2, until further processing.

**[0028]** When power source **21** is turned off, molten metal **30** is allowed to fall from induction crucible **10** through a niobium funnel **33** and into preheated secondary crucible **32**, which can remain stationary within casting machine **36** just long enough for molten metal **30** to complete its transfer into secondary crucible **32**, which in one embodiment may be from about 0.5 to about 2 seconds. Once the transfer of molten metal **30** is complete, secondary crucible **32** can be rapidly (about 1 to about 2 seconds) accelerated to full speed, which may be from about 100 rpm to about 600 rpm. Casting machine **36** can centrifugally force molten metal **30** out of

secondary crucible **32** and into casting mold **38** through port **40**, which may comprise at least one of a slit, hole, tube, or combination thereof. This quick transfer from secondary crucible **32** to casting mold **38** results in a contact time between the two of less than about 5 seconds. This brief contact time not only significantly reduces heat loss, but also helps ensure that there is no undesirable reaction between the molten metal and the graphite or ceramic used to construct secondary crucible **32**.

**[0029]** Casting mold **38** may comprise any ceramic investment casting system that provides an inert face coat and thermal insulating backing materials. As an example, in one embodiment, casting mold **38** may comprise a face coat including an oxide. As used herein, "oxide" refers to a composition selected from the group consisting of scandium oxide, yttrium oxide, hafnium oxide, a lanthanide series oxide, and combinations thereof. Furthermore, the lanthanide series oxide (also known as "rare earth" compositions) may comprise an oxide selected from the group consisting of lanthanum oxide, cerium oxide, praseodymium oxide, neodymium oxide, promethium oxide, samarium oxide, europium oxide, gadolinium oxide, terbium oxide, dysprosium oxide, holmium oxide, erbium oxide, ytterbium oxide, lutetium oxide, and combinations thereof. Casting mold **38** may comprise a backing including a refractory material selected from the group consisting of aluminum oxide, zirconium silicate, silicon dioxide, and combinations thereof, in a colloidal silica suspension.

**[0030]** Once the molten metal has been substantially transferred into casting mold **38**, centrifugal casting machine **36** can be turned off. The resulting component, which in one embodiment may be a low pressure turbine blade **42**, as shown in FIG. 4, can be removed from casting mold **38** using conventional practices. Because of the use of centrifugal casting, blade **42** needs little post-cast processing. The centrifugal forces generated by casting machine **36** provides for the optimized filling of casting mold **38** by improving the filling of thin sections of the mold, thereby providing a net shape component.

**[0031]** Moreover, because cold wall crucibles are used to melt the metal charge, there is less thermal stress on the crucible, and therefore, less crucible cracking. This can allow for both reuse of the crucible and fewer inclusions in the cast component. Additionally, since contact between the molten metal and secondary crucible is limited, there is a reduced likelihood of contamination of the molten metal from breakdown of the crucible. Less contamination can result in improved mechanical properties of the titanium alloy.

**[0032]** This written description uses examples to disclose the invention, including the best mode, and also to enable any person skilled in the art to make and use the invention. The patentable scope of the invention is defined by the claims, and may include other examples that occur to those skilled in the art. Such other examples are intended to be within the scope of the claims if they have structural elements that do not differ from the literal language of the claims, or if they include equivalent structural elements with insubstantial differences from the literal language of the claims.

What is claimed is:

1. A system for centrifugally casting a highly reactive titanium metal comprising:
  - a cold wall induction crucible for containing a titanium metal charge, the induction crucible having a plurality of induction coils and a removable bottom plate;



- a power source to heat the titanium metal charge in the induction crucible to obtain a molten metal;
- a preheated secondary crucible for catching the molten metal as it falls from the induction crucible after the removable bottom plate has been withdrawn and the power source turned off; and
- a centrifugal casting machine for holding and accelerating the secondary crucible to centrifugally force the molten metal into a casting mold and produce a cast component.
2. The system of claim 1 wherein the titanium metal charge comprises a titanium aluminide alloy.
3. The system of claim 1 wherein the bottom plate of the induction crucible is withdrawn using a method selected from the group consisting of sliding, rotating and dropping.
4. The system of claim 1 wherein the cast component comprises a low pressure turbine blade.
5. The system of claim 2 wherein the induction coils of the induction crucible are used to heat the metal charge to a temperature of from about 1480° C. to about 1557° C. to obtain the molten metal.
6. The system of claim 1 wherein the molten metal becomes suspended within the induction crucible.
7. The system of claim 2 wherein the secondary crucible is heated to a temperature of at least about 1000° C. when the secondary crucible comprises niobium and at least about 1082° C. when the secondary crucible comprises ceramic.
8. The system of claim 1 wherein:
- the centrifugal casting machine holds the secondary crucible stationary for from about 0.5 to about 2 seconds after the molten metal falls into the secondary crucible and, thereafter, the centrifugal casting machine accelerates the secondary crucible to from about 100 rpm to about 600 rpm within from about 1 second to about 2 seconds to centrifugally force the molten metal into the casting mold to produce the cast component.
9. A system for centrifugally casting a highly reactive titanium metal comprising:
- a cold wall induction crucible for containing a titanium metal charge, the induction crucible having a plurality of induction coils and a removable bottom plate;
- a power source to heat the titanium metal charge in the induction crucible to obtain a molten metal;
- a preheated secondary crucible for catching the molten metal as it falls from the induction crucible after the removable bottom plate has been withdrawn and the power source turned off;
- a funnel for transferring the molten metal from the induction crucible to the secondary crucible; and
- a centrifugal casting machine for holding and accelerating the secondary crucible to centrifugally force the molten metal into a casting mold and produce a cast component.
10. The system of claim 10 wherein the titanium metal charge comprises a titanium aluminide alloy.
11. The system of claim 9 wherein the bottom plate of the induction crucible is withdrawn using a method selected from the group consisting of sliding, rotating and dropping.
12. The system of claim 10 wherein the cast component comprises a low pressure turbine blade.
13. The system of claim 10 wherein the induction coils of the induction crucible are used to heat the metal charge to a temperature of from about 1480° C. to about 1557° C. to obtain the molten metal.
14. The system of claim 9 wherein the molten metal becomes suspended within the induction crucible.
15. The system of claim 10 wherein the secondary crucible is heated to a temperature of at least about 1000° C. when the secondary crucible comprises niobium and at least about 1082° C. when the secondary crucible comprises ceramic.
16. The system of claim 9 wherein:
- the centrifugal casting machine holds the secondary crucible stationary for from about 0.5 to about 2 seconds after the molten metal falls into the secondary crucible and, thereafter, the centrifugal casting machine accelerates the secondary crucible to from about 100 rpm to about 600 rpm within from about 1 second to about 2 seconds to centrifugally force the molten metal into the casting mold to produce the cast component.
17. A system for centrifugally casting a highly reactive titanium metal comprising:
- a cold wall induction crucible for containing a titanium aluminide charge, the induction crucible having a plurality of induction coils and a slidably removable bottom plate;
- a power source to heat the titanium aluminide charge in the induction crucible to obtain a molten titanium aluminide;
- a preheated secondary crucible for catching the molten titanium aluminide as it falls from the induction crucible after the removable bottom plate has been withdrawn and the power source turned off;
- a niobium funnel for transferring the molten titanium aluminide from the induction crucible to the secondary crucible; and
- a centrifugal casting machine for holding the secondary crucible stationary for from about 0.5 to about 2 seconds after the molten titanium aluminide falls into the secondary crucible and, thereafter, accelerating the secondary crucible to from about 100 rpm to about 600 rpm within from about 1 second to about 2 seconds to centrifugally force the molten titanium aluminide into a casting mold and produce a cast component.
18. The system of claim 17 wherein the induction coils of the induction crucible are used to heat the metal charge to a temperature of from about 1480° C. to about 1557° C. to obtain the molten metal.
19. The system of claim 17 wherein the secondary crucible is heated to a temperature of at least about 1000° C. when the secondary crucible comprises niobium and at least about 1082° C. when the secondary crucible comprises ceramic.
20. The system of claim 17 wherein the cast component comprises a low pressure turbine blade.

\* \* \* \* \*