



(19) **United States**

(12) **Patent Application Publication**  
**Islam**

(10) **Pub. No.: US 2008/0075460 A1**

(43) **Pub. Date: Mar. 27, 2008**

(54) **METHOD AND APPARATUS FOR SCHEDULING COMMUNICATION USING A STAR SWITCHING FABRIC**

*H04J 14/00* (2006.01)

(52) **U.S. Cl.** ..... 398/45; 370/351

(76) Inventor: **Mohammed N. Islam**, Allen, TX (US)

(57) **ABSTRACT**

Correspondence Address:  
**BAKER BOTTS L.L.P.**  
**2001 ROSS AVENUE**  
**SUITE 600**  
**DALLAS, TX 75201-2980 (US)**

In one embodiment, a scheduler for use with a star switching fabric includes a scheduling star switching fabric operable to receive a plurality of packets each associated with one of a plurality of wavelengths and a plurality of selecting elements associated with the scheduling star switching fabric. Each of the plurality of selecting elements is operable to contribute to selectively passing packets from the scheduling star switching fabric for receipt by a transmission star switching fabric. Packets received at the transmission star switching fabric over a given time period comprise a more uniform load distribution than packets received at an input to the scheduler over the same period of time.

(21) Appl. No.: **11/949,636**

(22) Filed: **Dec. 3, 2007**

**Related U.S. Application Data**

(63) Continuation of application No. 11/531,605, filed on Sep. 13, 2006, now Pat. No. 7,305,186, which is a continuation of application No. 10/005,998, filed on Dec. 3, 2001, now Pat. No. 7,110,671.

**Publication Classification**

(51) **Int. Cl.**

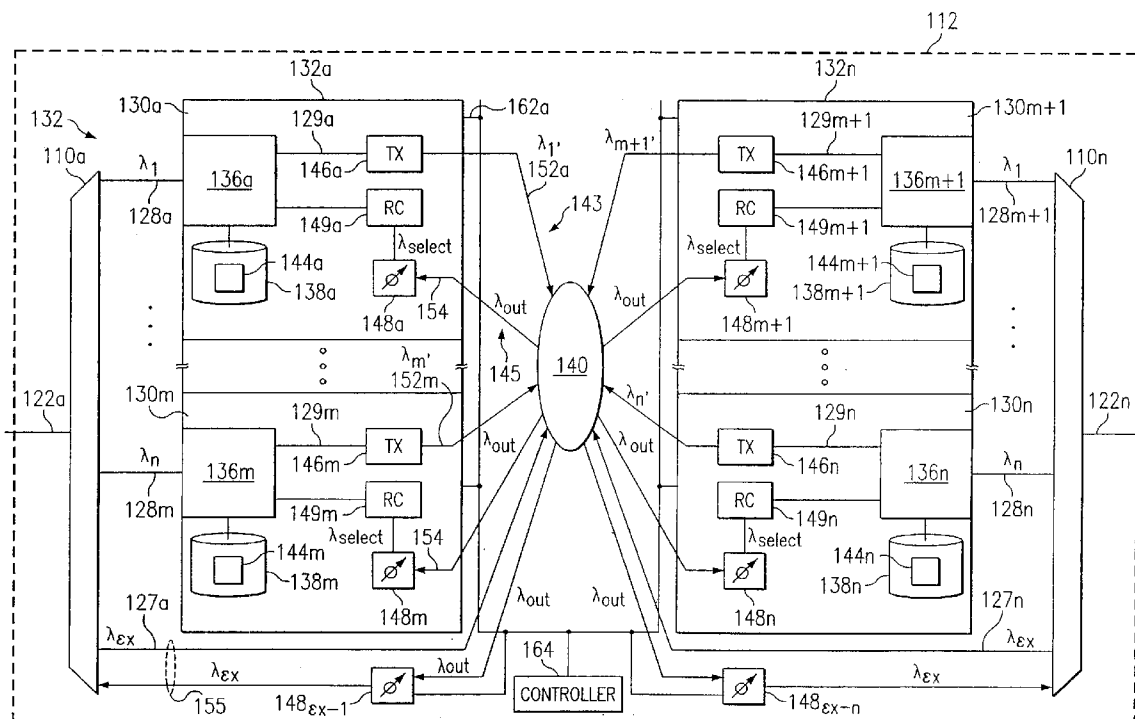

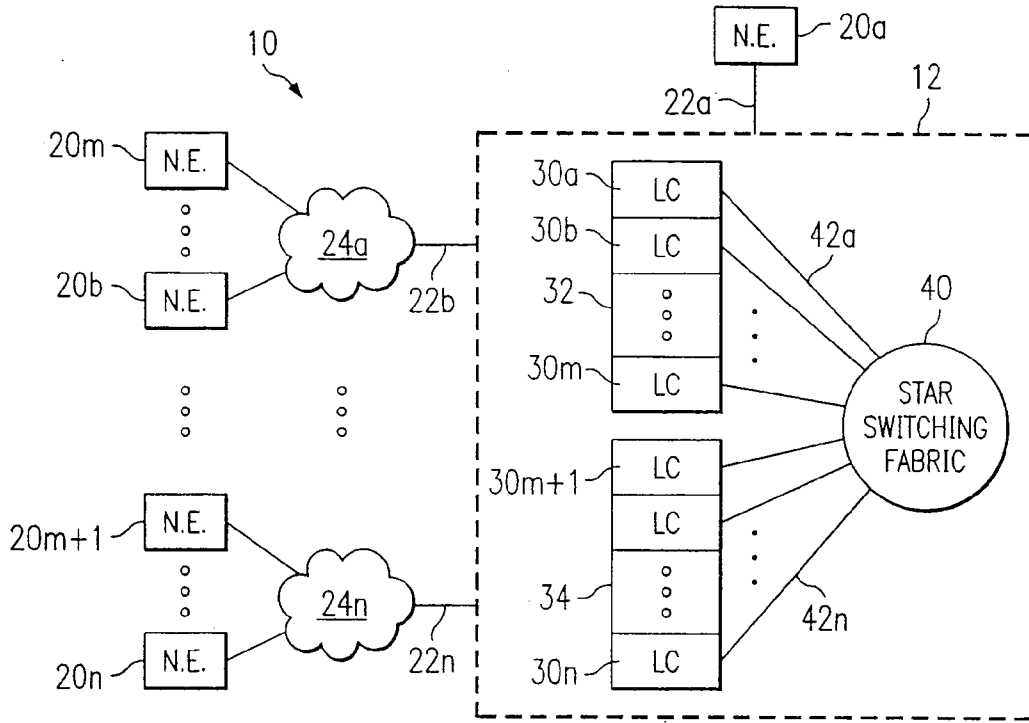

FIG. 1

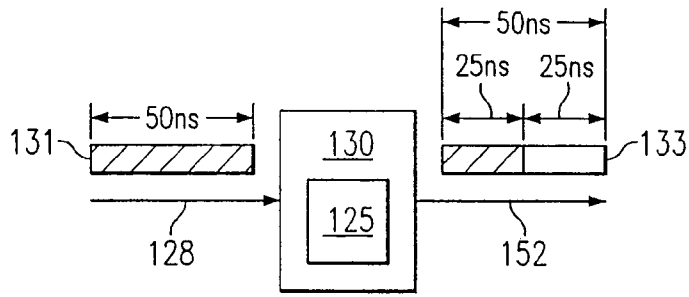

FIG. 8a

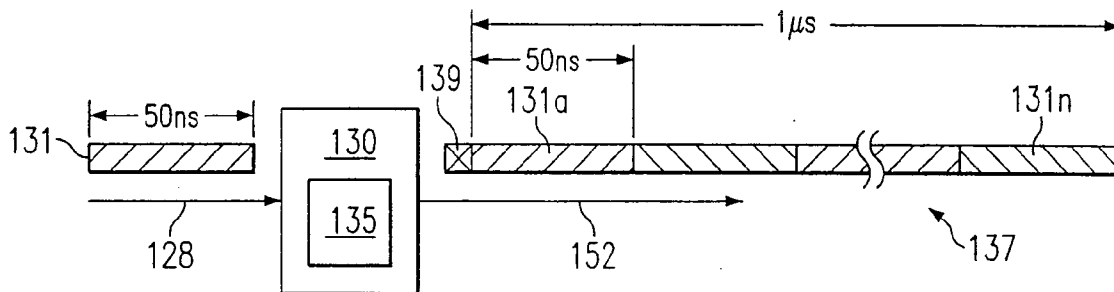

FIG. 8b

FIG. 2

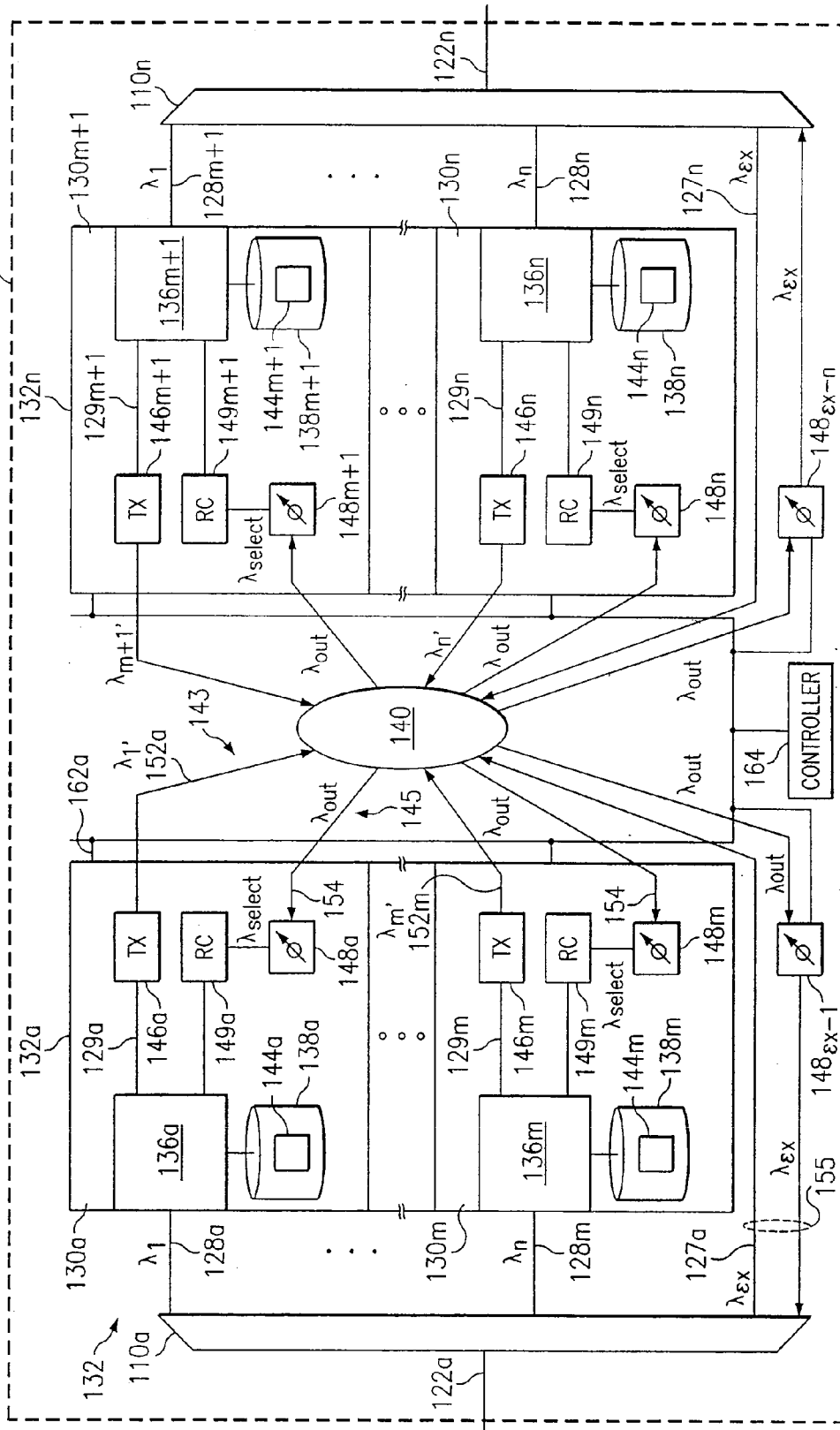
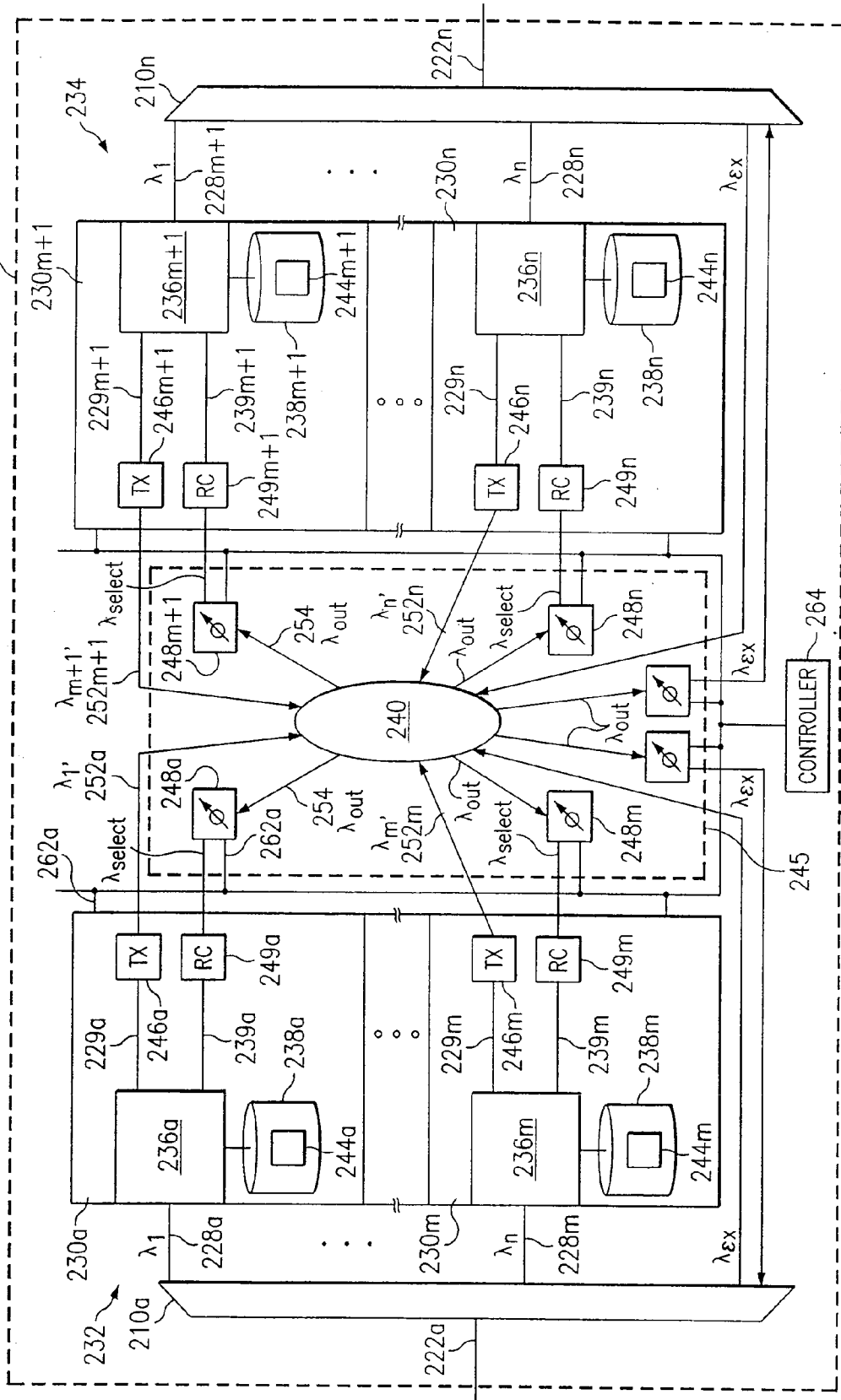

FIG. 3



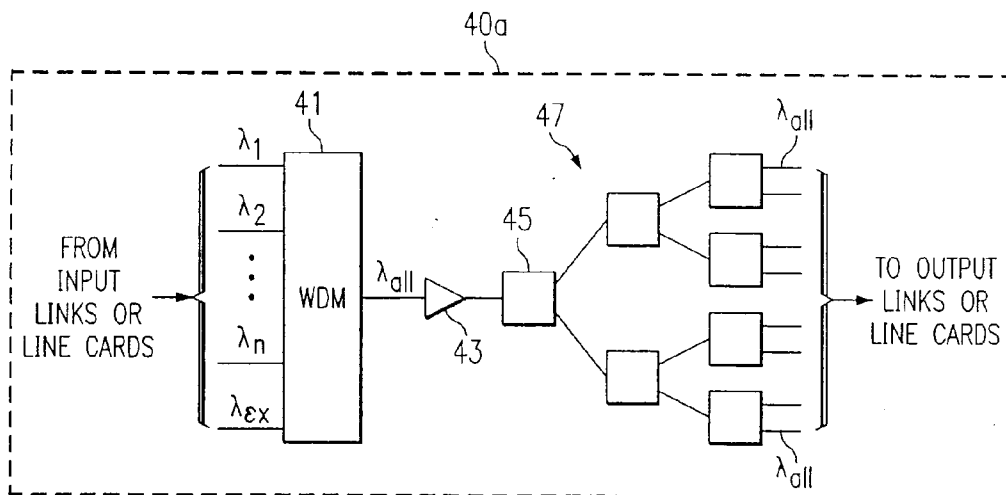

FIG. 4a

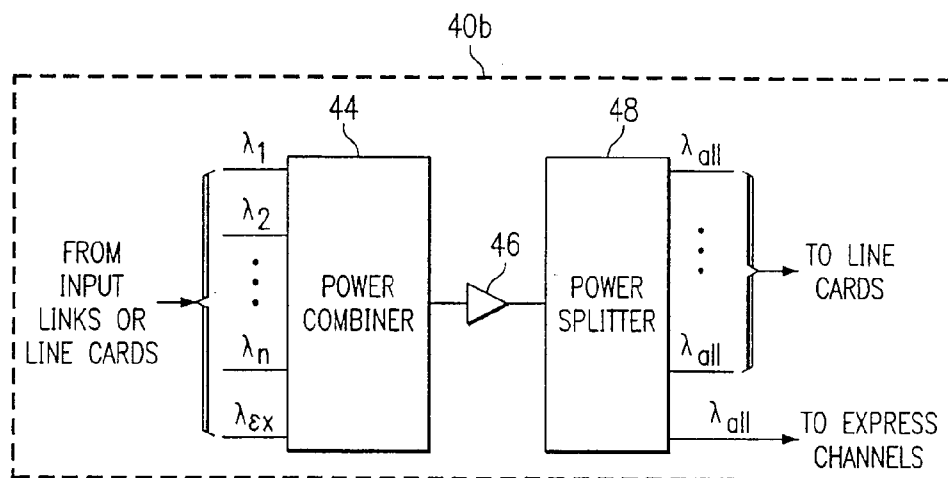

FIG. 4b

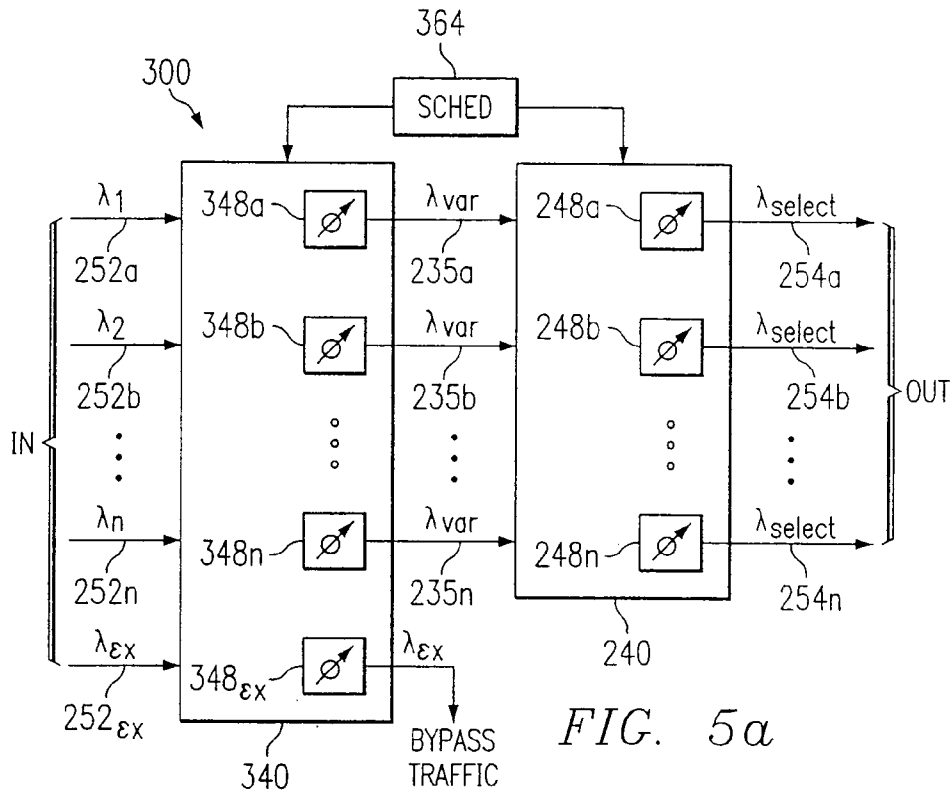

FIG. 5a

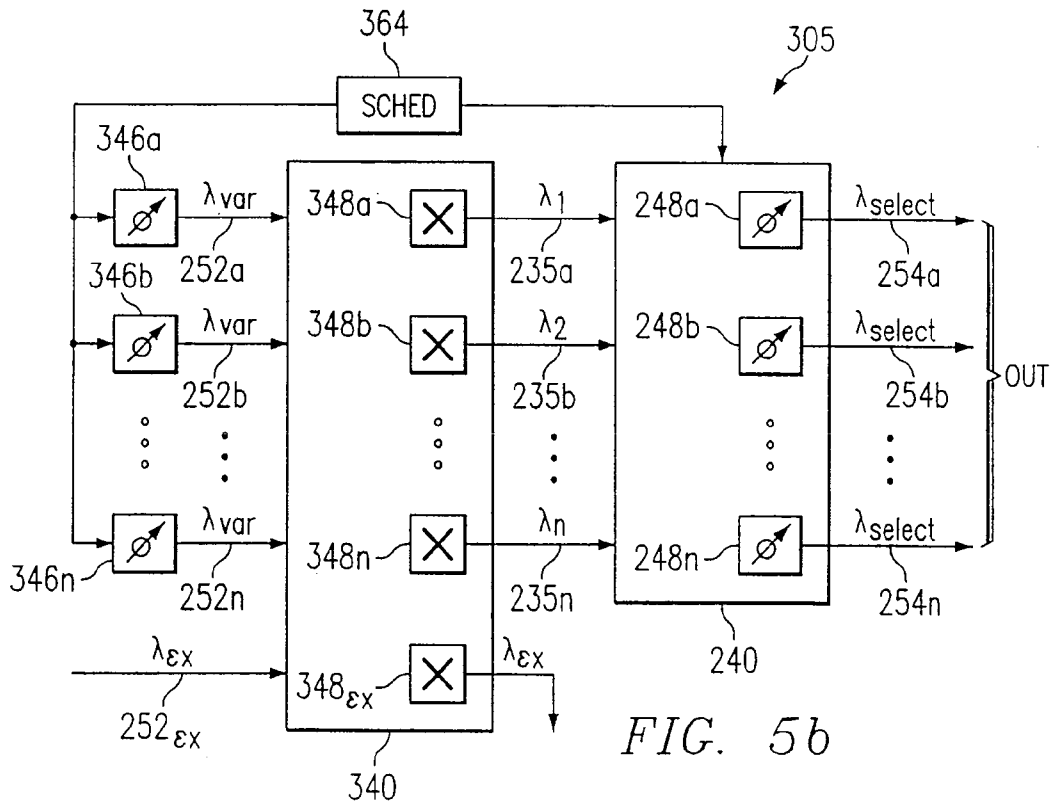

FIG. 5b

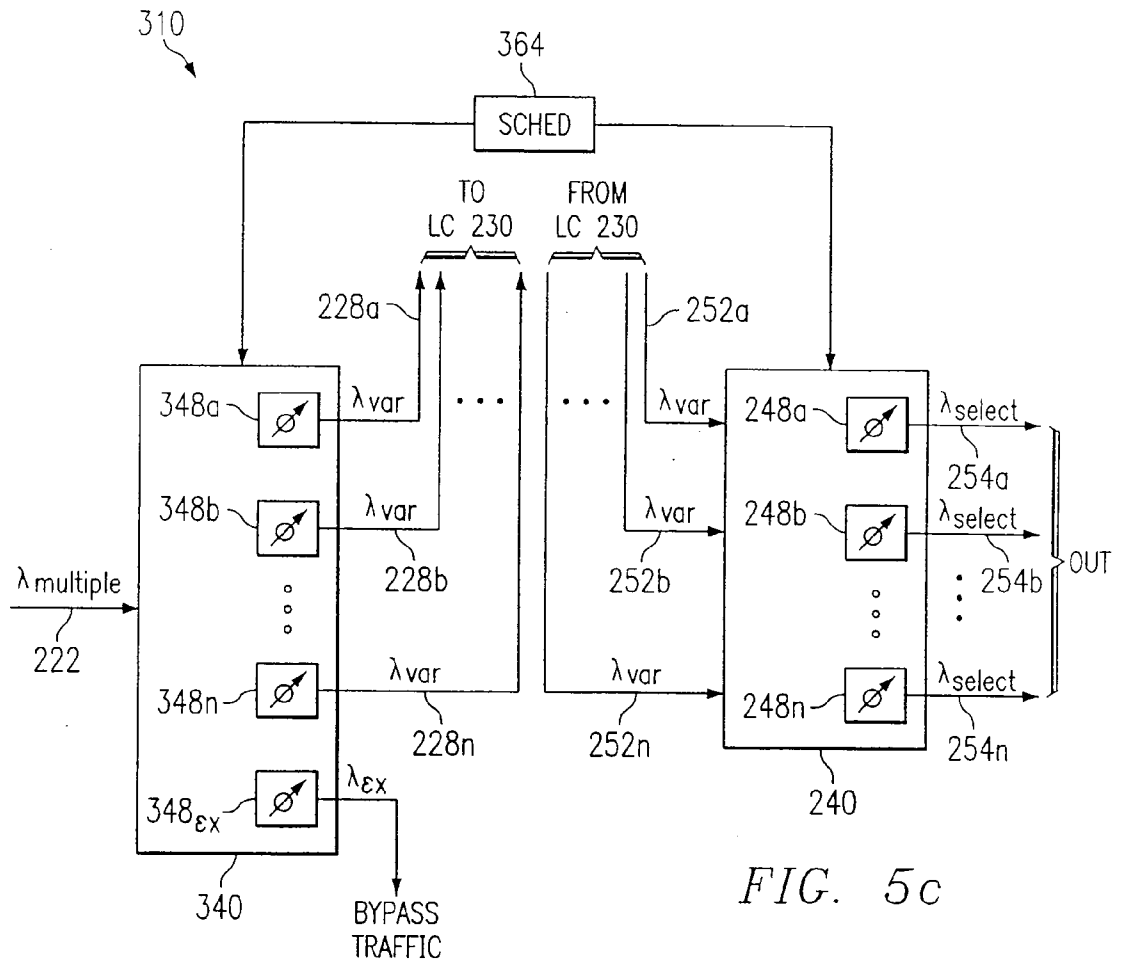

FIG. 5c

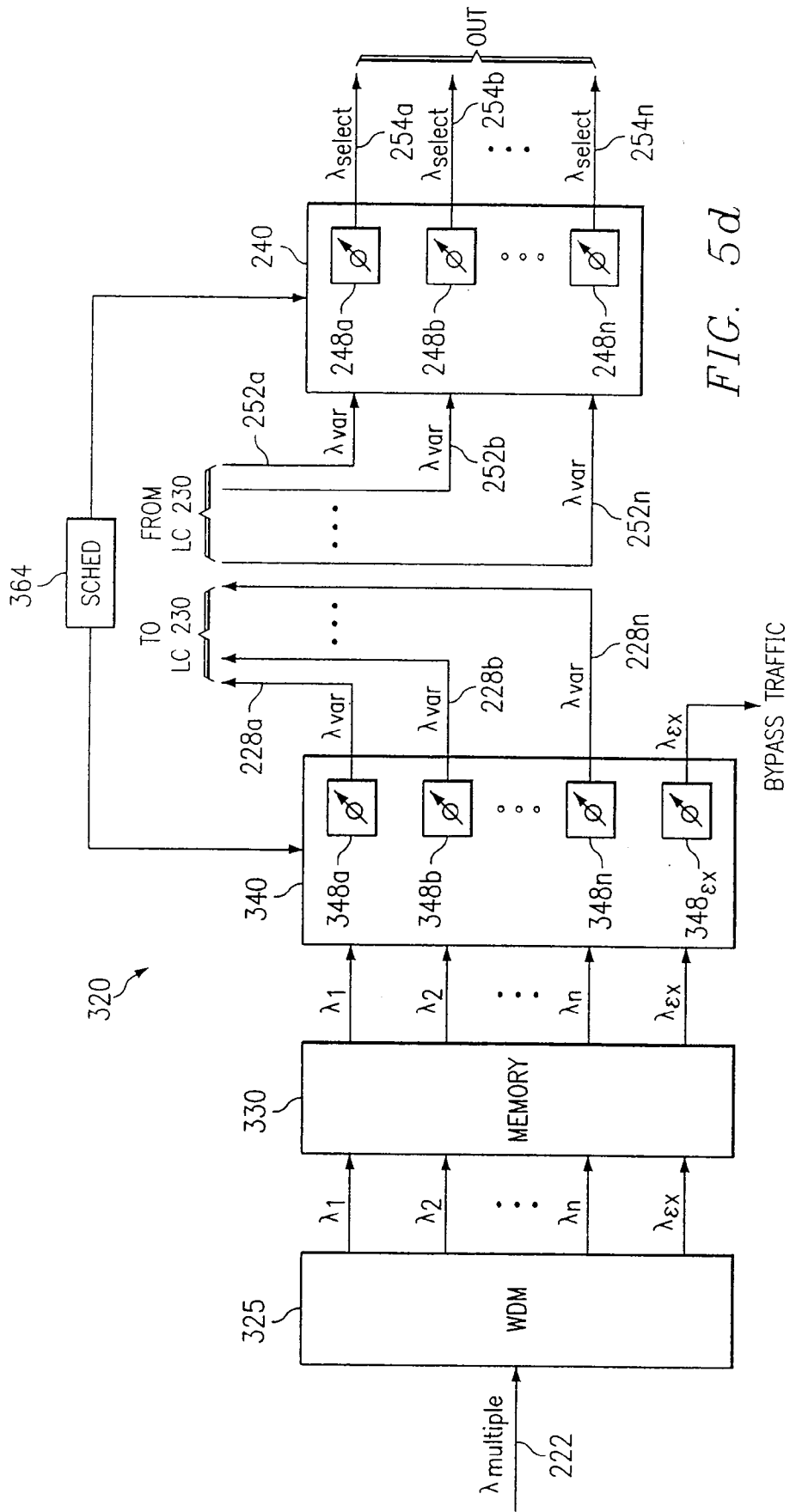

FIG. 5d



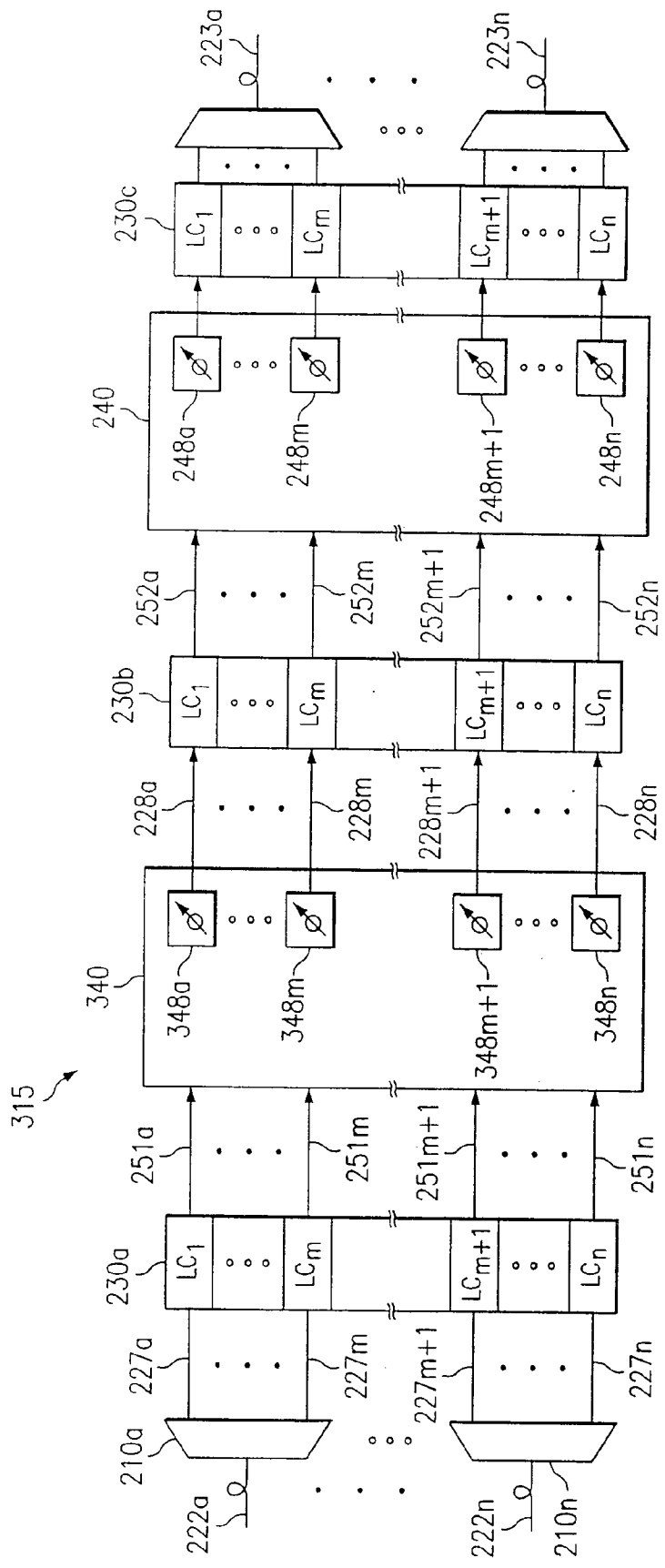

FIG. 6a

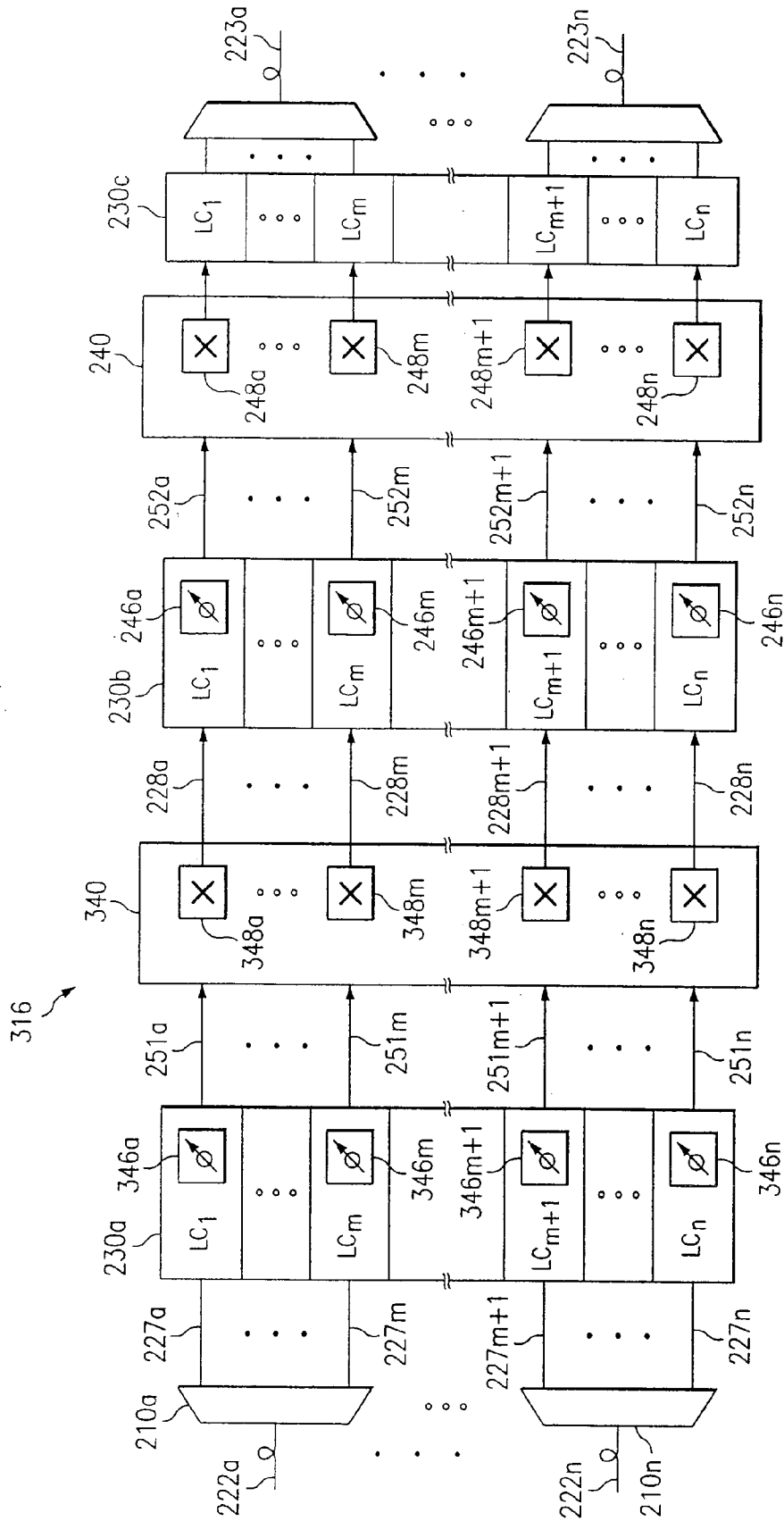

FIG. 6b

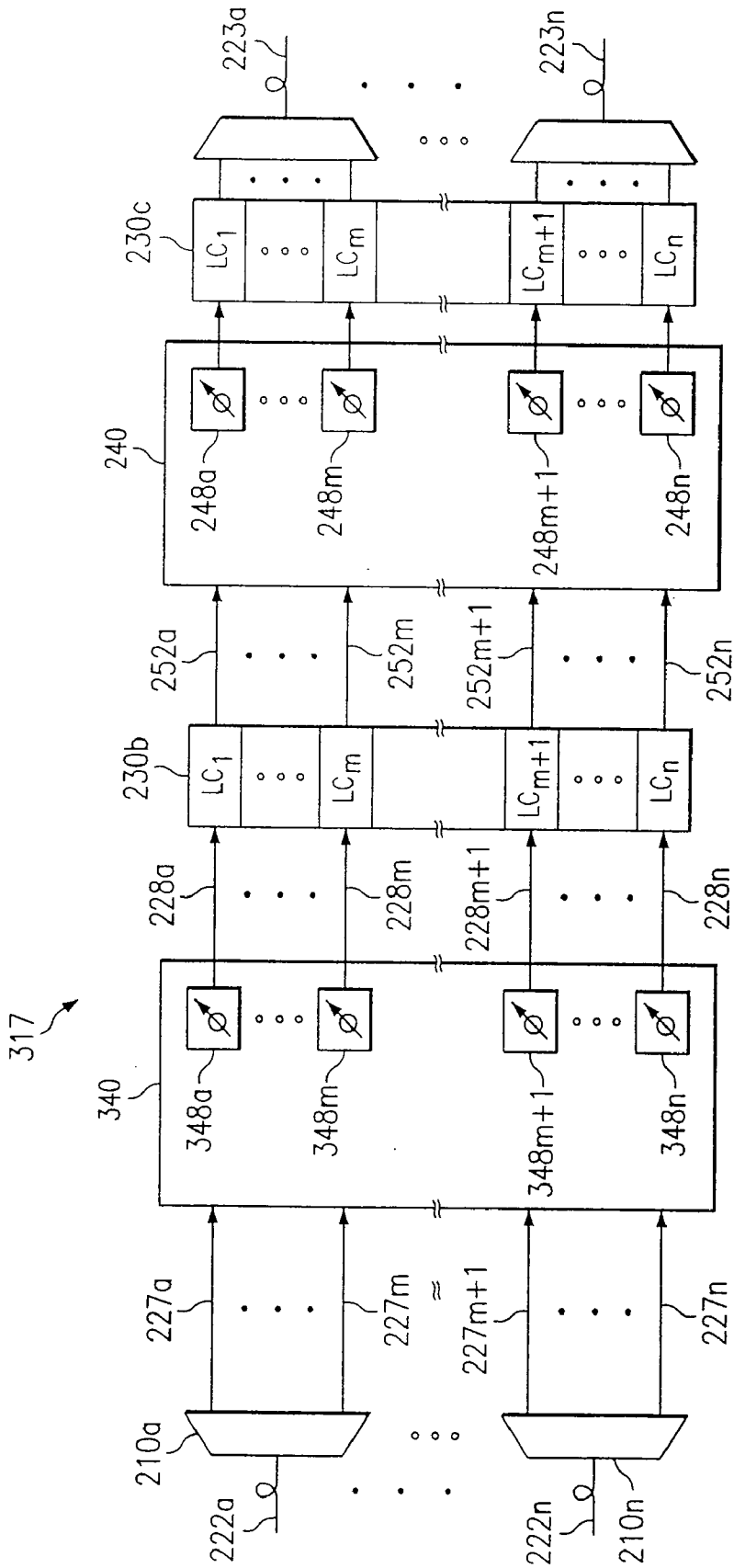

FIG. 6c

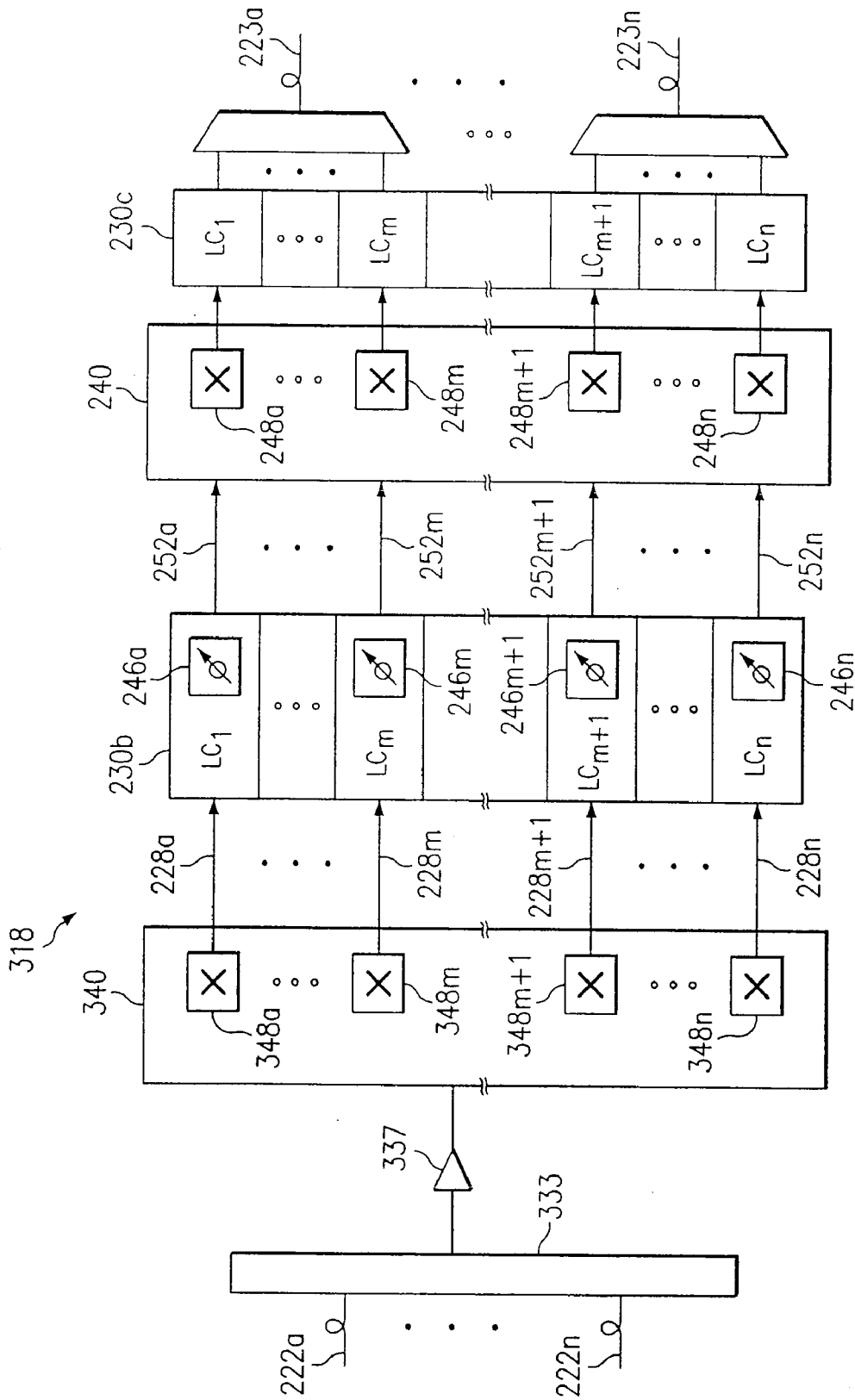

FIG. 6d

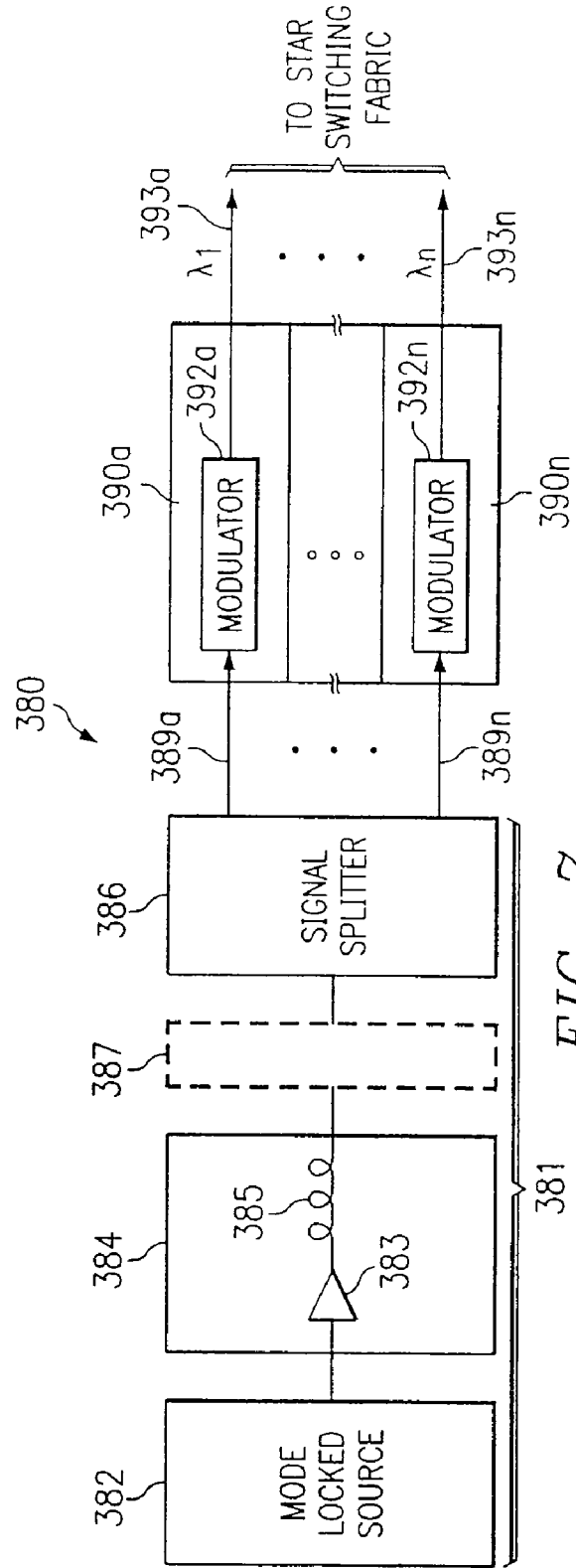

FIG. 7

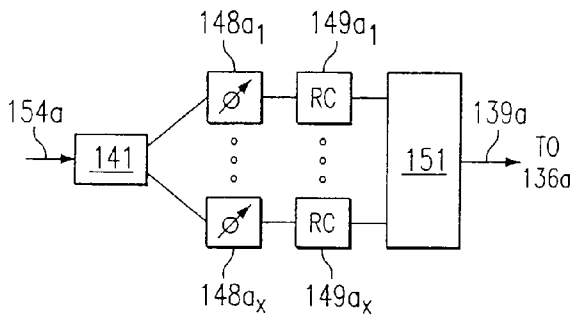

FIG. 9a

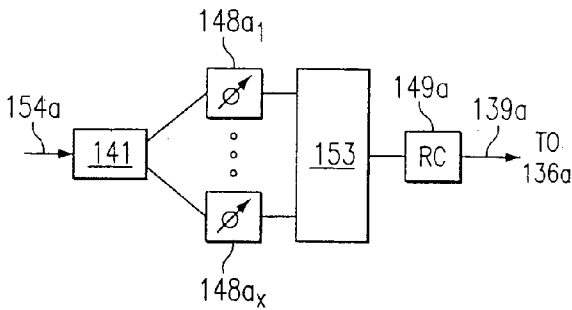

FIG. 9b

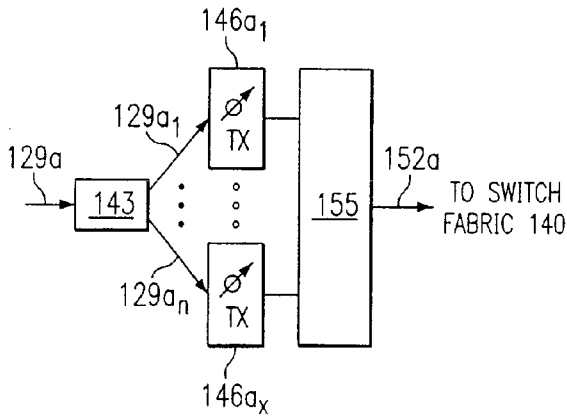

FIG. 9c

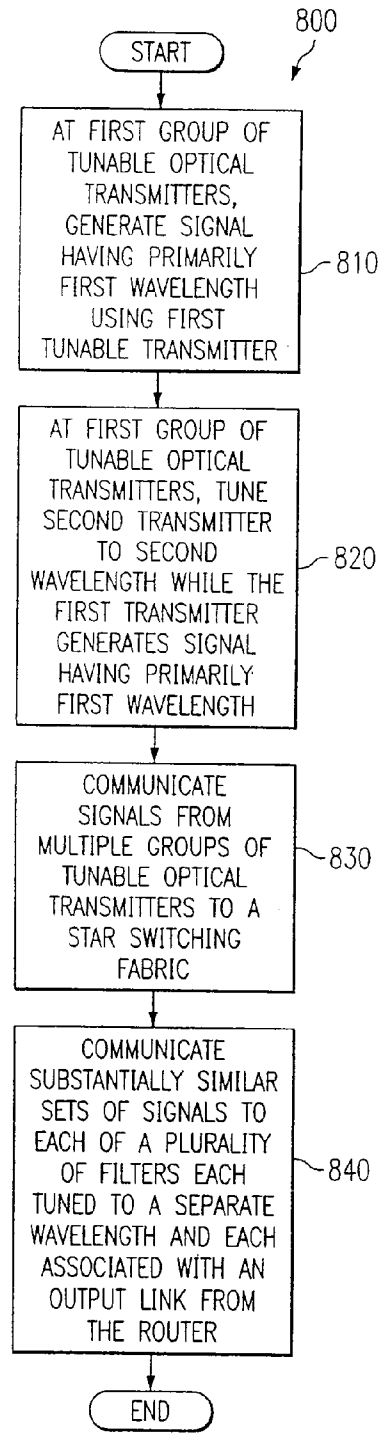

FIG. 16

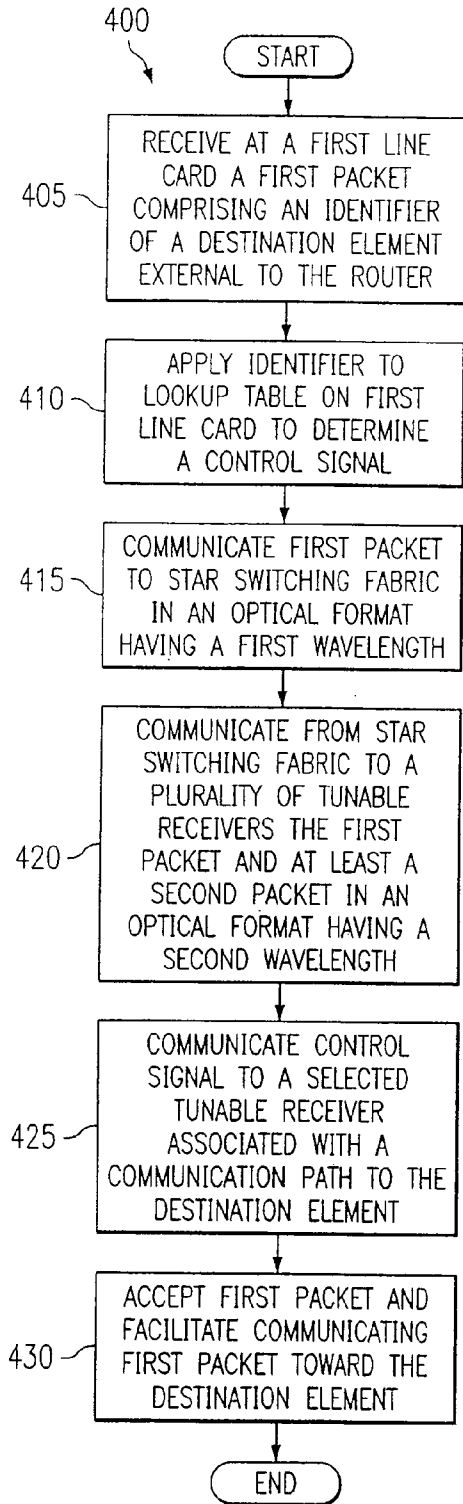

FIG. 10

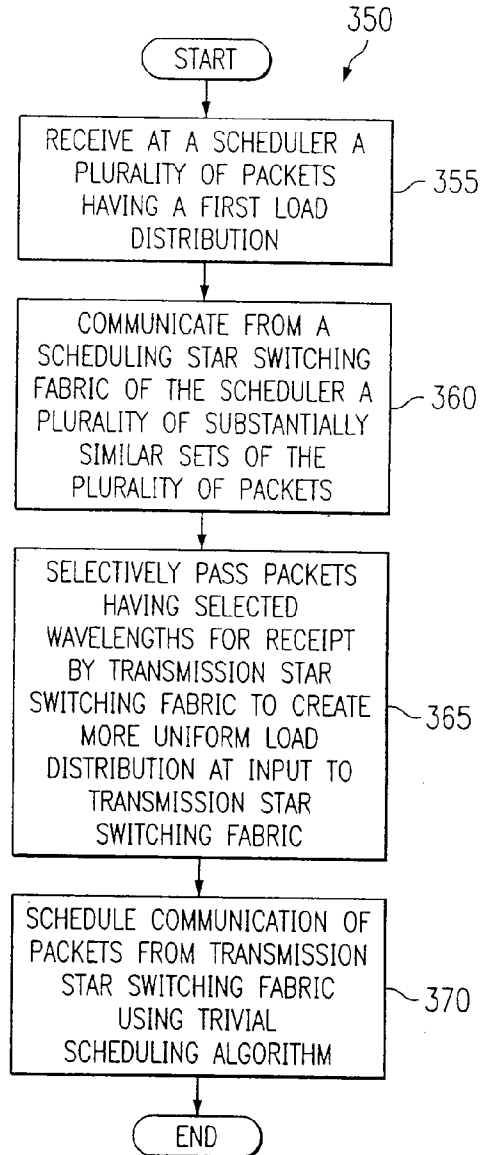

FIG. 11

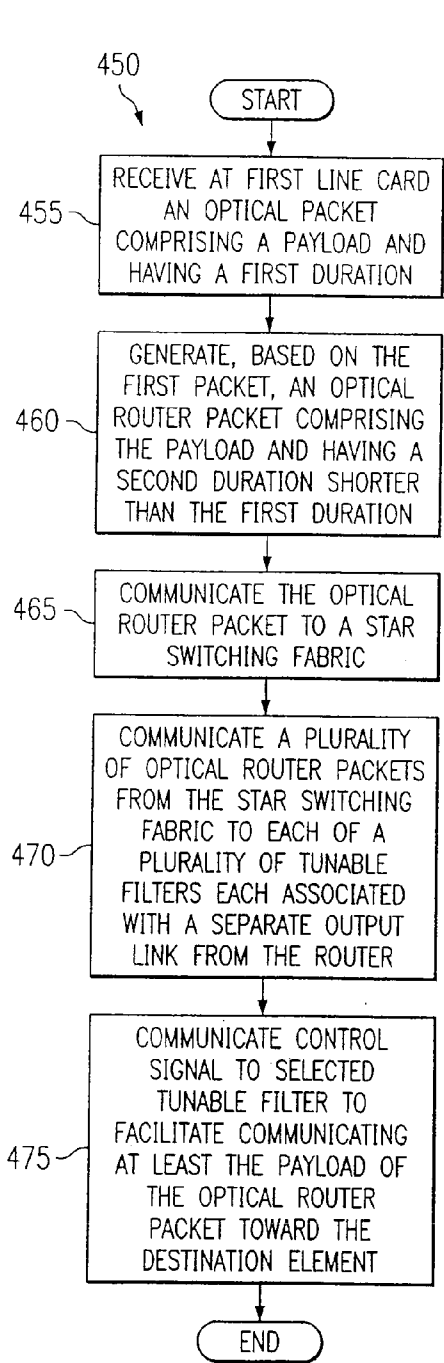

FIG. 12

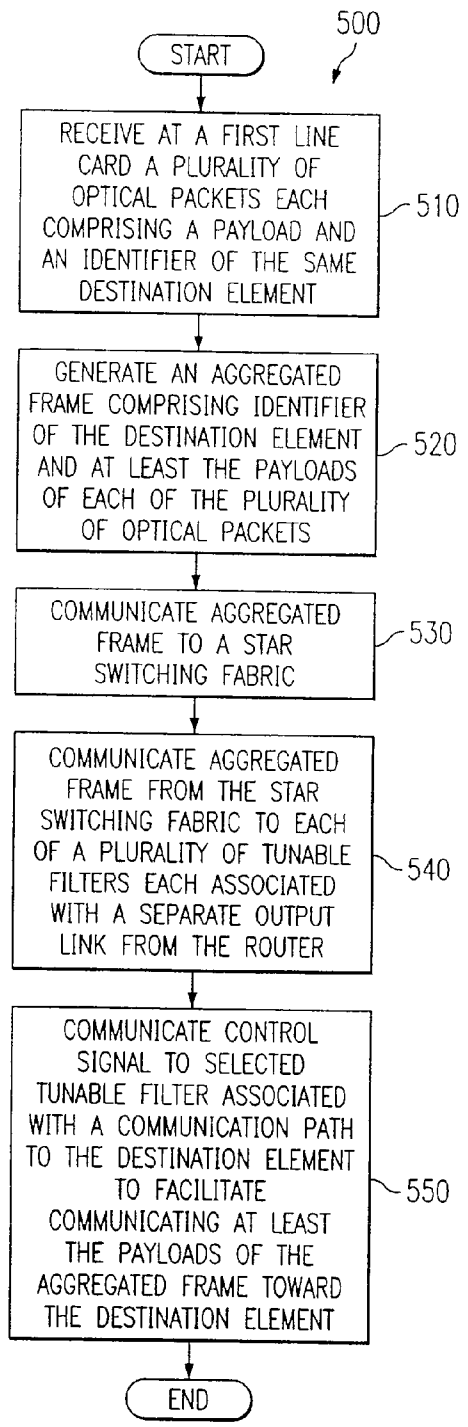

FIG. 13



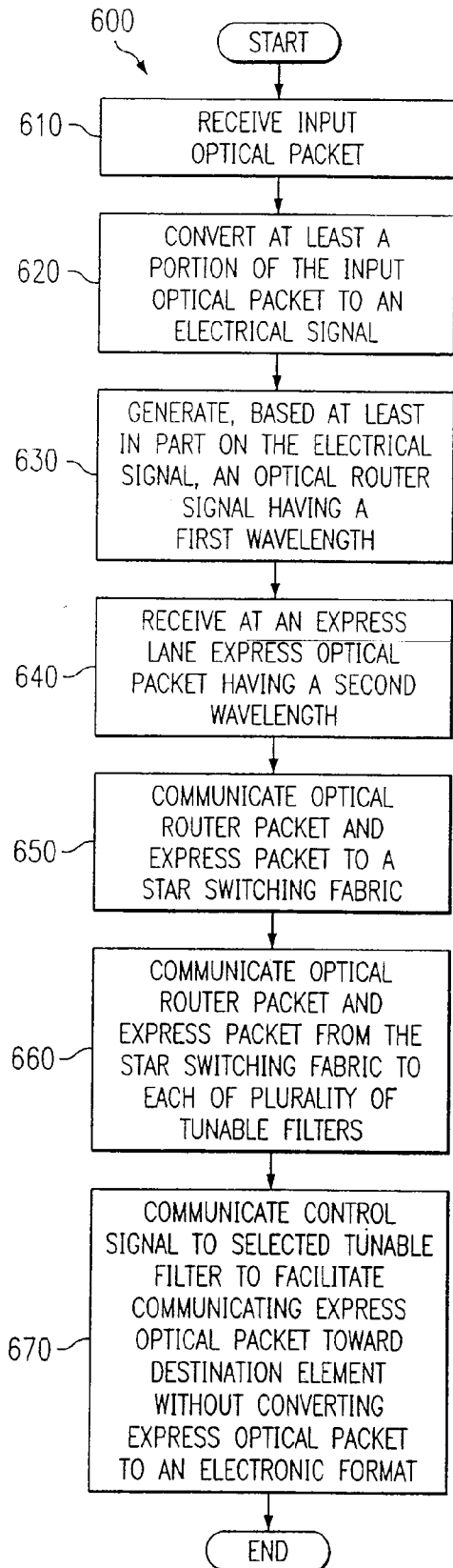

FIG. 14

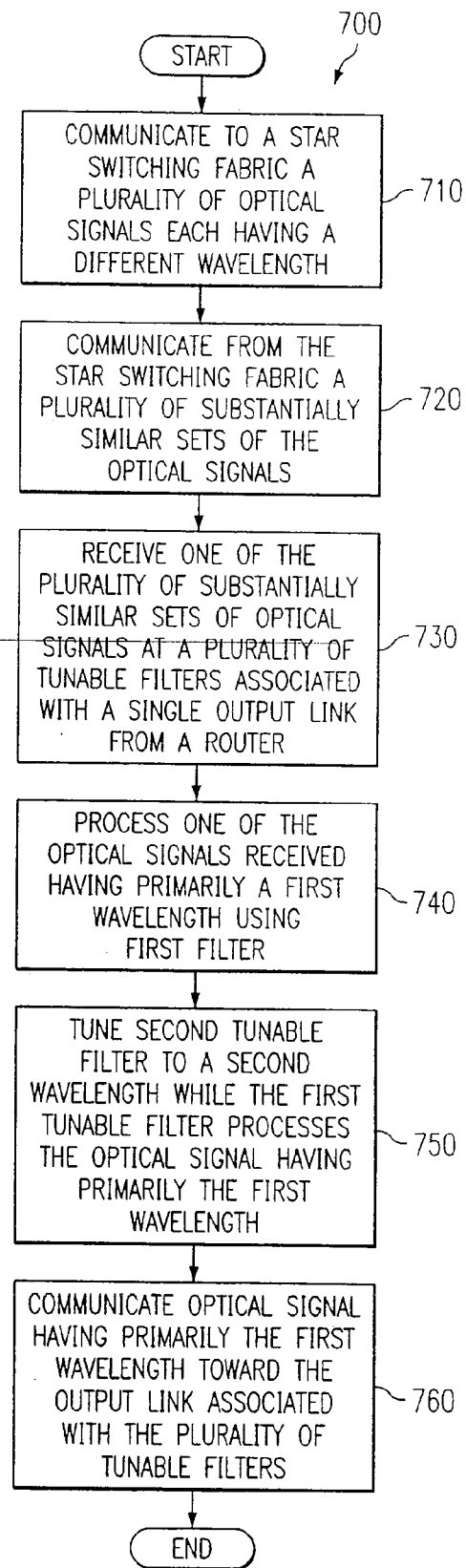

FIG. 15

**METHOD AND APPARATUS FOR SCHEDULING COMMUNICATION USING A STAR SWITCHING FABRIC**

**CROSS REFERENCE TO RELATED APPLICATIONS**

[0001] This application is a continuation of application Ser. No. 11/531,605 by Mohammed N. Islam, filed Sep. 13, 2006, entitled "METHOD AND APPARATUS FOR SCHEDULING COMMUNICATION USING A STAR SWITCHING FABRIC," currently pending, which is a continuation of application Ser. No. 10/005,998 by Mohammed N. Islam, filed Dec. 3, 2001, entitled "METHOD AND APPARATUS FOR SCHEDULING COMMUNICATION USING A STAR SWITCHING FABRIC," now U.S. Pat. No. 7,110,671B1.

**TECHNICAL FIELD OF THE INVENTION**

[0002] The present invention relates to the field of communication systems, and more particularly to an apparatus and method for scheduling communication through a star switching fabric.

**BACKGROUND**

[0003] As optical systems continue to increase the volume and speed of information communicated, the need for methods and apparatus operable to facilitate high speed optical signal processing also escalates. Router and switch cores performing optical switching generally implement schedulers to assist in avoiding contention for common system resources. In prior approaches, there has generally been a tension between the complexity of the scheduler used and the delay experienced in the switching fabric. More complex schedulers generally require significant system resources and can be difficult to implement. Trivial schedulers, while simple to implement, have generally resulted in unsatisfactory switching delays.

**OVERVIEW OF VARIOUS EXAMPLE EMBODIMENTS**

[0004] The present invention recognizes a need for a method and apparatus operable to efficiently and effectively facilitate scheduling of communication through a star switching fabric. In one embodiment, a scheduler for use with a star switching fabric comprises a scheduling star switching fabric operable to receive a plurality of packets each associated with one of a plurality of wavelengths, and a plurality of selecting elements associated with the scheduling star switching fabric. Each of the plurality of selecting elements is operable to contribute to selectively passing packets from the scheduling star switching fabric for receipt by a transmission star switching fabric. Packets received at the transmission star switching fabric over a given time period comprise a more uniform load distribution than packets received at an input to the scheduler over the same period of time.

[0005] In a method embodiment, a method of scheduling operation of a star switching fabric comprises receiving at a scheduler a plurality of packets each having a wavelength and communicating from a scheduling star switching fabric of the scheduler a plurality of substantially similar sets of the plurality of packets. The method further comprises selec-

tively passing packets having selected wavelengths from the scheduling star switching fabric for receipt by a transmission star switching fabric. Packets received at the transmission star switching fabric over a given time period comprise a more uniform load distribution than packets received at an input to the scheduler over the same time period.

[0006] Depending on the specific features implemented, particular embodiments may exhibit some, none, or all of the following technical advantages. One embodiment provides a way to schedule communication of optical signals through a star switching fabric using a simple scheduling algorithm while maintaining good throughput. Other technical advantages are readily apparent to one of skill in the art from the attached figures, description, and claims.

**BRIEF DESCRIPTION OF THE DRAWINGS**

[0007] For a more complete understanding of the present invention, and for further features and advantages thereof, reference is now made to the following description taken in conjunction with the accompanying drawings, in which:

[0008] FIG. 1 is a block diagram illustrating an exemplary communication system implementing aspects of the present invention;

[0009] FIG. 2 is a block diagram of one example embodiment of an optical implementing aspects of the present invention;

[0010] FIG. 3 is a block diagram of another example embodiment of an optical implementing aspects of the present invention;

[0011] FIGS. 4a-4b are block diagrams illustrating example star switch fabric architectures;

[0012] FIGS. 5a-5d are block diagrams illustrating example scheduling mechanisms for use with star switching fabrics, including those described herein;

[0013] FIGS. 6a-6d are block diagrams illustrating additional example scheduling mechanisms for use with star switching fabrics, including those described herein;

[0014] FIG. 7 is a block diagram illustrating an example embodiment of a continuum optical source for use with a star switching fabric, including those described herein;

[0015] FIGS. 8a-8b are block diagrams illustrating example mechanisms useful in increasing the speed of optical routers including those described herein;

[0016] FIGS. 9a-9c are block diagrams illustrating additional example mechanisms useful in increasing the speed of optical routers including those described herein;

[0017] FIG. 10 is a flow chart showing one example of a method of routing optical signals using a star switching fabric;

[0018] FIG. 11 is a flow chart showing one example of a method of scheduling communications through a star switching fabric;

[0019] FIG. 12 is a flow chart illustrating one example of a method of enhancing the effective switching speed of an optical router by reducing the duration of packets communicated through a star switching fabric of the router;

[0020] FIG. 13 is a flow chart showing one example of a method of enhancing the effective switching speed of an optical router by aggregating packets bound for a common output communication path;

[0021] FIG. 14 is a flow chart showing one example of a method of enhancing the effective switching speed of an optical router using a star switching fabric by providing express lanes that bypass line cards performing electronic signal processing of some of the optical signals received;

[0022] FIG. 15 is a flow chart showing one example of a method for enhancing the effective switching speed of an optical router using a star switching fabric by assigning a plurality of tunable filters to each output link from the router; and

[0023] FIG. 16 is a flow chart showing one example of a method of enhancing the effective switching speed of an optical router using a star switching fabric by assigning a plurality of tunable transmitters to an input link to the optical router.

#### DETAILED DESCRIPTION OF VARIOUS EXAMPLE EMBODIMENTS

[0024] FIG. 1 is a block diagram illustrating an exemplary communication system 10 operable to facilitate communication of optical signals. In this example, system 10 includes a router 12 coupled to a plurality of network elements 20a-20n. Router 12 facilitates directing optical communication signals between various elements within and/or coupled to system 10. Throughout this document, the term “coupled” denotes any direct or indirect communication between two or more elements said to be “coupled” to one another. Elements coupled to one another may, but need not, be physically connected to one another. Additional elements may or may not reside between two elements said to be “coupled” to one another.

[0025] As used throughout this document, the term “router” refers to any hardware, firmware, software, or combination thereof operable to receive signals from various sources and to direct signals received toward one or more destinations depending at least in part on an identifier associated with the signal and its destination.

[0026] In one particular embodiment, signals received by router 12 comprise packets. As used throughout this document, the term “packet” refers to signals having fixed or variable size, each comprising an identifier associated with a destination network element. While some of the packets may comprise traffic terminating at router 12, at least some of the packets contain identifiers identifying destination elements external to router 12. The packets could comprise, for example Internet Protocol (IP) packets or a Transmission Control Protocol (TCP) packets including an address identifying a destination network element. As another example, each incoming optical signal could comprise a Multi-Protocol Label Switching (MPLS) packet or Generalized Multi-Protocol Label Switching (GMPLS) packet comprising a tag identifying a destination network element.

[0027] In some cases, the “destination network element” may comprise a node within or coupled to system 10, but external to router 12, to which information in the optical signal is ultimately destined. In other cases, the “destination network element” may comprise a node external to router 12

in a communication path between router 12 and an element to which the information is ultimately destined. In that case, the “destination network element” comprises an intermediate network element facilitating further routing of the information to the ultimate destination network element. In still other cases, router 12 may comprise the destination element.

[0028] Network elements 20a-20n communicate optical signals over system 10. Network elements 20 may comprise any hardware, software, firmware, or combination thereof operable to transmit and/or receive information via communication system 10. Router 12 communicates with network elements 20 via communication links 22a-22n. Communication links 22 may comprise, for example, optical fibers. Communication links 22a-22n could, however, comprise any land based or space based communication medium, or combination of such media operable to communicate one or more optical signals.

[0029] Network elements 20 can couple directly to communication links 22, or may couple to communication links 22 through one or more networks 24. Each of networks 24 could comprise, for example, a data network, a public switched telephone network (PSTN), an integrated services digital network (ISDN), a local area network (LAN), a wide area network (WAN), or other communication system or combination of communication systems at one or more locations. Networks 24 may comprise wireless networks, wireline networks, or combinations of wireless and wireline networks. Network elements 20 and/or router 12 can reside with networks 24 or externally to those networks.

[0030] In this particular example, router 12 comprises a plurality of line cards 30a-30n. As used throughout this document, the term “line card” can include any hardware, software, firmware, or combination thereof operable to receive incoming optical signals from communication links 22 and to convert at least a portion of at least some of the incoming optical signals to electrical signals to facilitate electronic decision making with respect to those signals. In the illustrated embodiment, each line card 30 is associated with an optical transmitter operable to generate, based at least in part on the electrical signals received, an optical router signal for transmission within router 12. The optical transmitters may comprise, for example, laser diodes, light emitting diodes, or other light emitting sources.

[0031] Line cards 30 may reside in one or more physically separate locations. In this particular example, a first plurality of line cards 30a-30m reside in a first rack 32, while a second plurality of line cards 30m+1-30n reside in a second rack 34. As one specific example, first rack 32 and second rack 34 may each hold sixteen line cards 30. Additional or fewer numbers of line cards and numbers of racks could be used without departing from the scope of the invention.

[0032] In this example, racks 32 and 34 are physically separated from one another. In one embodiment, racks 32 and 34 may be separated by a distance where communication speed considerations make it desirable to implement optical communication between racks 32 and 34. Line cards 30 in racks 32 and 34 advantageously use optical communication links 42a-42n to facilitate high speed communication. In this particular example, optical communication links 42a-42n interconnect through an optical switching fabric 40.

[0033] Switching fabric 40 comprises hardware, software, firmware, or combinations thereof operable to facilitate

directing optical router signals between line cards **30** and/or express channels (not explicitly shown in this figure), which bypass line cards **30**. In a particular example, switching fabric **40** comprise a star switching fabric. Throughout this document, the term “star switching fabric” refers to a device and/or functionality operable to receive a plurality of input optical signals from a plurality of sources and to communicate a substantially similar set of at least some of the input optical signals to each of a plurality of destinations. In one particular embodiment, star switching fabric **40** resides within one of racks **32** or **34**.

[0034] In the example illustrated in FIG. 1, switching fabric **40** could comprise a star switching fabric operable to receive a plurality of input optical router signals from plurality of line cards **30** and to communicate substantially similar sets each comprising at least some of the input optical router signals back to at least some of the plurality of line cards **30** and/or express channels bypassing line cards **30**. Fused fiber couplers, waveguide star couplers, arrayed waveguide gratings, power splitters, wavelength division multiplexers, cascaded 2x2 couplers, nxn couplers and cascades of these couplers are just a few examples of devices that could form star switching fabric **40**.

[0035] In a particular embodiment, switching fabric **40** advantageously interconnects line cards **30** residing within different racks **32** and **34**, and facilitates communicating optical router signals between line cards **30** without requiring electrical-to-optical or optical-to-electrical signal conversions within switching fabric **40**. This design can increase the speed of the router, and could also reduce the physical size, power dissipation, and cost of the router. In one particular embodiment, switching fabric **40** could occupy less than one third of the space of rack **32** or **34**, leaving substantial room for additional line cards and other processing elements.

[0036] In one example embodiment, router **12** includes a plurality of tunable filters. A tunable filter can comprise any hardware, software, and/or firmware operable to selectively substantially communicate one or more wavelengths of light while substantially rejecting other wavelengths of light. In this example, each tunable filter is associated with one of line cards **30** or with an express channel.

[0037] Each tunable filter is operable to receive a plurality of optical signals and to select one or more signals for processing by tuning to a wavelength associated with the selected signals. The use of tunable filters in router **12** advantageously facilitates efficient multicast and/or broadcast operation simply by tuning multiple filters, each associated with a separate line-card or express channel, to a common wavelength.

[0038] In operation, router **12** receives a plurality of input optical signals from communication links **22**. One or more optical links can carry signals at wavelengths designated as express channels within router **12**. Express channels route directly through switching fabric **40** from inputs of router **12** to outputs of router **12**, bypassing line cards **30**.

[0039] With respect to non-bypass traffic, line cards **30** receive at least some of the input optical signals and convert all or a portion of those signals to an electronic format to facilitate electronic decision making processing. As one particular example, one or more line cards **30** receive

packets and convert at least a destination identifier portion of the packet into an electronic format. Line cards **30** then use the electronic destination identifier information to assist in directing the packet to a destination network element.

[0040] Optical transmitters associated with line cards **30** generate input optical router signals based at least in part on processing of the electronic signals. Router **12** communicates the input optical router signals and any bypass traffic to switching fabric **40**, where a plurality of input optical router signals and any bypass traffic are combined to form an output optical router signal. The output optical router signal comprises information from some or all of the plurality of input optical router signals and/or express channel signals.

[0041] Switching fabric **40** facilitates communicating the output optical router signal to at least some of a plurality of tunable filters, each associated with an output link from router **12**. Tunable filters receive the output optical router signal and tune to a selected wavelength associated with a portion of the output optical router signal destined for a line card **30** associated with that filter or an express channel output link associated with that filter. The selected portion of the output optical router signal can carry the packet bound for the destination network element.

[0042] Where a line card **30** is associated with the tunable filter, the line card facilitates communication of the received packet from the associated filter to the destination network element. This may include, for example, passing the packet in optical form to an output communication link, or converting the packet to an electrical format for further processing within router **12**. Router **12** may also perform wavelength conversion prior to passing the signals toward the destination network element.

[0043] FIG. 2 is a block diagram of one particular embodiment of router **112**. In this example, router **112** includes a plurality of wavelength division multiplexer/demultiplexers (WDM) **110a-110n**. Each WDM is associated with one or more optical links **122** carrying wavelength division multiplexed optical signals. Wavelength division multiplexers/demultiplexers **110** receive incoming WDM signals from optical links **122** and separate the incoming signal into a plurality of channels  $\lambda_1$ - $\lambda_n$  for processing within line cards **130**. On the output side, wavelength division multiplexers/demultiplexers **110** combine a plurality of signals into one or more multiple wavelength output signals.

[0044] In this particular example, incoming signals received at links **122** also include one or more express channels  $\lambda_{\text{Ex}}$ , which traverse router **112** over bypass links **155** without being processed by line cards **130**. Express channels  $\lambda_{\text{Ex}}$  are communicated directly to switching fabric **140** without any optical-to-electrical conversion. Implementing express channels can provide significant advantages in avoiding unnecessary processing of particular groups of optical signals. Although this example shows just one express link, any number of express links could be provided. Traffic entering router **12** can be divided between processed traffic and express traffic, for example, by designating particular wavelengths in WDM signals **122** accordingly.

[0045] In the illustrated embodiment, router **112** comprises a plurality of racks **132a-132m** of line cards **130** each coupled to a switching fabric **140**. In this example racks

**132a** and **132n** are physically separated from one another and switching fabric **140** serves as an all-optical interconnect between line cards **130** in racks **132a** and **132n**. In other embodiments, all line cards **130** could reside locally to one another, for example, in a single rack.

[0046] In the illustrated example, each line card **130** includes a processor **136**. Alternatively, some of all of line cards **130** could share central processing resources accessible to line cards **130**. In any case, processor or processors **136** operate to convert at least a portion of an input optical signal **128** arriving from one of communication links **22** to an electrical format. For example, input optical signal **128** may comprise a packet having a destination identifier, such as a TCP address, an IP address or, an MPLS or GMPLS tag. Processor **136** operates to convert at least the destination identifier portion of the packet to an electrical format to facilitate electronic decision making functions with respect to that packet.

[0047] In this example, each line card **130** comprises a memory **138**. Memory **138** may comprise any hardware, software, and/or firmware operable to facilitate storage and/or retrieval of electronic information. Although in this example memory **138** is shown as residing entirely within line card **130**, all or a portion of memory **138** could alternatively reside at another location remote from but accessible to line card **130**.

[0048] Each memory **138** stores a look-up table **144** operable to facilitate electronic decision making to result in communicating incoming optical signals **128** from router **112** toward destination network elements residing externally to router **112**. Look-up table **144** may comprise any data structure, compilation, or other arrangement of information facilitating generation of instructions based at least in part on information contained in a signal to be routed. As one particular example, using an identifier of the destination element from a received packet, processor **136** may index look-up table **144** to obtain instructions on directing the packet through router **112** and toward the destination element. Look-up table **144** can, for example, facilitate TCP/IP routing based on an address associated with the destination element. Alternatively, look-up table **144** can facilitate label switching based on an MPLS or GMPLS routing protocol.

[0049] In some cases, router **112** may comprise an edge router facilitating communication of packet traffic received in one format through a subnetwork operating with another format. For example, router **112** could receive IP or TCP packets from an IP network and convert those packets to an MPLS or GMPLS format for transmission through a label switching portion of a network. In that case, the packets traversing switch fabric **140** would comprise MPLS or GMPLS packets.

[0050] Each line card **130a-130n** further comprises an optical transmitter **146a-146n** operable to receive an electronic signal **129a-129n** and to generate an input optical router signal **152a-152n**, respectively, based at least in part on the received electronic signal **129a-129n**. Each optical transmitter may comprise, for example, a laser diode, although any optical transmitter could be used without departing from the scope of the invention. Optical transmitters **146** may comprise directly modulated or externally modulated lasers. Alternatively, one or more of optical transmitters **146** may comprise lasers having integrated modulators, such as electro-absorption modulators.

[0051] In one particular embodiment, each optical transmitter **146** comprises a fixed wavelength laser. Throughout this document, the term “fixed wavelength laser” denotes a laser operable to generate optical signals at approximately one predetermined wavelength or range of wavelengths, and which does not during operation perform selective adjustment of the output wavelength. Lasers whose output wavelength varies during operation due to, for example, fluctuations in environmental conditions are not intended to be excluded from the definition of a “fixed wavelength” laser. Moreover, tunable lasers operated without intentionally selectively varying the output wavelength of the laser during operation are intended to be within the definition of a “fixed wavelength” laser.

[0052] Although some embodiments of the invention implement tunable lasers, using fixed wavelength lasers **146** provides an advantage of reducing cost and complexity of router **112** compared to solutions requiring tunable lasers. In addition, one aspect of the invention recognizes that using fixed wavelength lasers, each transmitting at a different wavelength, reduces or eliminates collisions in the switching fabric.

[0053] In this example, each optical link **128** is associated with a tunable filter. In the illustrated embodiment, each of line cards **130a-130n** includes a tunable filter **148a-148n**, respectively. Each express channel **127** also includes a tunable filter **148ex1-148exn**. Tunable filters **148** may each comprise, for example, a tunable optical filter operable to selectively communicate particular optical router signals **152** from output optical router signal **154**. As one example, tunable filters **148** could each comprise a Fabry Perot interferometric device. In a particular embodiment, the filter could comprise a micro-electromechanical switch (MEMS) device capable of tuning at speeds faster than once each one hundred nanoseconds.

[0054] Although many other tunable filter designs could be implemented without departing from the scope of this disclosure, the following provides a brief description of one such device.

[0055] A Fabry Perot interferometric micro electromechanical switching (MEMS) device typically implements a stationary mirror structure and a moveable mirror structure, which form between them an optical cavity having a depth that can be selectively altered by applying a force to the moveable mirror structure. In one particular novel design, the moveable mirror structure can be supported by actuators surrounding the moveable mirror structure.

[0056] The actuators can comprise, for example, a stationary conductor and a moveable conductor, which form between them an electrode gap. A voltage difference applied between the two conductors creates an electrostatic force tending to move the moveable conductor toward the stationary conductor.

[0057] The actuators can be placed in symmetric locations around the moveable mirror and coupled to the moveable mirror. Locating the actuators around the mirror facilitates independent selection of the nominal optical cavity depth and the electrode gap depth. Thus, this design facilitates optimizing both the optical characteristics of the interferometer through selection of the optical cavity depth, and separate optimization of the electrical characteristics of the

device through independent selection of the electrode gap depth. Moreover, by forming the interferometer and actuators in this manner, the dimensions of the moveable conductor can be optimized to provide high speed and low drive voltage.

[0058] In some embodiments, the moveable mirror assembly of the interferometer can be supported by a frame that substantially surrounds and/or covers the moveable mirror. The frame and location of the actuators help to avoid deformation of the moveable mirror structure during actuation, resulting in better optical characteristics for the device. Although details of one particular tunable filter have been described here, other tunable filter designs could be used. Other MEMs designs, lithium niobate tunable filters, and liquid crystal tunable filters provide a few examples.

[0059] Line cards 130 can also include a converter 149 operable to convert the recognized portion 152 of output optical router signal 154 into an electrical signal 129 for further processing within router 112.

[0060] Router 112 includes a control network 160 operable to communicate control signals 162 to facilitate selection of a communication path through router 112 and on to the destination element. In one embodiment, control signals 162 direct tunable filters 148 to tune to a specified wavelength or range of wavelengths to facilitate selection of an appropriate optical router signal 152 from multiple wavelength output optical router signal 154. As a particular example, control network 160 could comprise an Ethernet. Although other control network configurations could be used without departing from the scope of the invention, an Ethernet provides an advantage of efficient and economical operation at speeds sufficient to control and reset filters 148 between receipt of sequential optical router signals.

[0061] In an alternative embodiment, control network 160 could comprise a plurality of control lasers each operable to generate and communicate to filters 148 an optical control signal 162 at, for example a designated control frequency. In this embodiment optical control signals are communicated via switching fabric 140. Router 112 may, for example, communicate control signals to filters 148 prior to communicating optical router signals to filters 148. In that way, filters 148 can be provisioned to accept selected optical router signals 152 depending on the state of an optical control signal 162.

[0062] Router 112 may include a scheduler 164 coupled to control network 160. Scheduler 164 can operate to provide scheduling functionality to avoid or reduce contention in transmission of control signals 162 to filters 148. FIGS. 5a-5d discussed below provide details of example scheduling mechanisms useful with any star switching fabric, including the design discussed herein with respect to FIGS. 2 and 3.

[0063] Router 112 interconnects line cards 130 using switching fabric 140 including communication links 143 and 145. Communication links 143 couple lasers 146 to switching fabric 140, while communication links 145 couple filters 148 to switching fabric 140. In this example, communication links 143 and 145 comprise single mode fibers.

[0064] In operation, wavelength division multiplexer/demultiplexers 110 receive one or more multiple wavelength signals 122 and separate input signals 128a-128n including

express channels 127 from one another. Express channels 127a-127n are directed to switching fabric 140 without performing optical-to-electrical conversions on those signals.

[0065] Processor(s) 136 associated with line cards 130 receive input optical signals 128a-128n and converts at least a portion of each signal to an electronic format. In one embodiment, processor(s) 136 can operate to convert to an electronic form the entire contents including the header and payload portions of incoming optical signal 128. Processor(s) 136 apply at least a destination identifier portion of the electronic signal 129 to look-up table 138 to determine communication instructions for the signal. Optical transmitter 146 can then form an optical router signal 152 by transforming electronic information into optical router signal 152.

[0066] In another embodiment, processor(s) 136 may convert only a header portion of input optical signal 128 to electronic form leaving the payload portion in optical form. In that case, processor(s) 136 may perform electronic processing on the header to determine routing of the signal, and then pass the header or a modified version thereof to optical transmitter 146. In that embodiment, optical transmitter 146 produces an optical header, which is then combined with the optical payload portion of the signal to form an optical router signal for transmission through switching fabric 140. In that embodiment, the portion of the input optical signal that is not converted to an electronic format can be passed through a delay element, such as a buffer or a delay line, to facilitate delay while the identifier portion of the packet is electronically processed.

[0067] Each optical transmitter 146 communicates to switching fabric 140 an optical router signal 152 at a particular wavelength. Where optical transmitters 146 comprise fixed wavelength lasers, each optical transmitter 146 transmits its optical router signal 152 at a predetermined specified wavelength associated with that particular transmitter 146, which is different from wavelengths transmitted from other transmitters 146. Where optical transmitters 146 comprise tunable lasers, each laser communicates its optical router signal 152 at a wavelength determined by a control signal from, for example, processor 136.

[0068] In this particular embodiment, each processor 136 determines a control signal 162 based at least in part on applying a destination identifier to the look-up table 144 associated with that line card 130. In some embodiments control signal 162 may identify an output communication link 128 coupling to the destination network element. In other cases, control signal 162 may identify a filter 148 associated with the identified output link 128. Router 112 communicates control signals 162 via control circuitry 160 to tunable lasers 146 and/or tunable filters 148 to selectively enable communication paths through router 112.

[0069] Transmitters 146 each communicate an optical router signal 152 to switching fabric 140. In this particular example, switching fabric 140 comprises a star coupler switching fabric. Star coupler switching fabric 140 receives a plurality of optical router signals 152 and may also receive one or more express channels 127 each having substantially different wavelengths. Switching fabric 140 combines information from at least some of the optical router signals 152 and/or at least some of the express channels 127 into an

output optical router signal 154. Each output optical router signal 154 comprises a substantially similar set of optical router signals 152 and/or express channels 127. Star switching fabric communicates optical router signal 154 to some or all of filters 148.

[0070] In a particular embodiment, transmitters 146 comprise fixed wavelength lasers while filters 148 comprise tunable filters. This embodiment provides an advantage of minimizing cost by implementing low cost tunable filters as compared to relatively higher cost tunable lasers. In addition, implementing tunable filters readily facilitates multicast and/or broadcast operation simply by provisioning the tunable filters to receive a plurality of the optical router signals communicated from switching fabric 140.

[0071] In this example, router 112 communicates control signals 162 to scheduler 164 and/or to a tunable filter 148 associated with a communication path leading to the destination network element. Filters 148 receive control signals 162 and selectively tune to receive particular wavelengths as directed by control signals 162. In this manner, tunable filters 148 selectively receive only the portion of output optical router signal 154 communicated from switching fabric 140 that is intended for further transmission toward the destination element.

[0072] In an alternative embodiment, transmitters 146 may comprise tunable optical lasers. In that embodiment, lasers 146 may receive control signals 162 and communicate optical router signals 152 to switching fabric 140 at selected wavelengths predetermined to match wavelengths of filters 148 associated with communication paths leading to the destination network elements.

[0073] Filters 148 receive specified portions of output optical router signal 154 corresponding to the packet desired for transmission to the destination network element. In one embodiment, each filter 148 comprises an optical filter operable to communicate only optical router signals having a specified wavelength. In a particular embodiment, the received optical router signal can be communicated without further processing in router 112 to the destination network element. In another embodiment, each line card 130 may also include a converter 149 operable to convert an optical router signal received from an associated filter 148 to an electronic format for further processing within router 112 before conversion back to an optical format to be communicated toward the destination network element.

[0074] FIG. 3 is a block diagram illustrating another embodiment of a router 212. Router 212 is similar in structure and function to router 112 shown in FIG. 2, except that in this case, tunable filters 248 reside remotely from line cards 230 and in close proximity to or integrally with switching fabric 240.

[0075] Router 212 includes a plurality of line cards 230 each associated with an optical transmitter 246 and a tunable filter 248. Each line card 230 is coupled to a switching fabric 240 via communication links 243 and 245. Switching fabric 240 operates to receive a plurality of input optical router signals 252a-252n from optical transmitters 246a-246n and one or more express channel signals 227 and to generate an output optical router signal 254 comprising information from at least some of the input optical router signals 252a-252n and/or express channel signals 227.

[0076] In one particular embodiment, optical transmitters 246 comprise fixed wavelength transmitters each operable to generate a particular wavelength signal. In this embodiment, filters 248 each comprise a tunable optical filter operable to receive multiple signals each having different wavelengths and to tune to receive only a selected wavelength signal in response to a control signal 262. In this example, tunable filters 248 selectively tune to a particular wavelength or range of wavelengths based on control signal 262 from control network 260. Control network 260 may comprise, for example, an Ethernet or other suitable network or combination of communication links operable to communicate an electronic control signal 262. Alternatively, control network 260 could comprise control lasers operable to communicate optical control signals 262 via switching fabric 240.

[0077] In this embodiment, optical transmitters 246 reside on their associated line cards 230, while tunable filters reside remotely from line cards 230. In this example, tunable filters 248 and switching fabric 240 comprise a router core 245 for router 256. In this embodiment, router core 245 includes switching fabric 240 combined with closely coupled tunable filters 248. Removing tunable filters 248 from line cards 236 and integrating those filters into router core 245 can provide significant advantages. For example, removing tunable filters 248 from line cards 236 provides additional space on each line card for other processing elements, or facilitates reducing the physical size of each line card. This allows for additional line cards to reside in any given rack. Moreover, integrating filters 248 within router core 245 at or near switching fabric 240 facilitates the use of arrays of filters, rather than individually packaged filters for each channel. Coupling switching fabric 240 to an array of tunable filters can significantly reduce packaging costs and, thus, the overall cost of the router.

[0078] Filters 248, in this example, are coupled to switching fabric 240 using optical connections 255. Each optical connection 255 may comprise, for example, a short length of fiber or a planar waveguide. In the illustrated embodiment, each of communication links 243 coupling optical transmitters 246 to switching fabric 240 comprises a single mode fiber. Communication links 245 coupling filters 248 to line cards 230 may comprise single mode or multi-mode fibers. Communication networks using star couplers have traditionally used single mode fibers to couple network elements both to and from the star coupler. One aspect of the invention recognizes that in certain embodiments, such as where filters 248 reside remotely from line cards 230, the use of multi-mode fibers to couple one or more filters 248 to associated line cards 230 can provide an advantage of reducing cost of router 212 without significantly degrading performance of the device.

[0079] As discussed above, star switching fabric 40 can assume any of a variety of physical embodiments. For example, a plurality of fibers can be physically fused together to provide star switching capabilities. In addition, wave guide star couplers and arrayed wave guide gratings can be used to provide star switching functionality. FIGS. 4A-4B depict two particular embodiments of novel star switching architectures that can be implemented in any system using star switching functionality, including the optical routers described herein. In particular, FIG. 4A shows a wavelength-based star switching fabric 40a. Wave-

length-based star switching fabric **40a** includes a wavelength division multiplexer **41**. Wavelength division multiplexer **41** receives a plurality of individual wavelength signals and combines those signals into a wavelength division multiplexed signal. Wavelength division multiplexer **41** may receive individual wavelength signals, for example, from line cards at input ports to a router, or may receive express lane traffic directly from input ports to the router.

[0080] Wavelength-based switching fabric **40a** includes at least one optical amplifier **43** operable to receive and amplify the wavelength division multiplex signal generated by wavelength division multiplexer **41**. Optical amplifier **43** could comprise any of a variety of amplifier types, such as a distributed Raman amplifier, a discrete Raman amplifier, a rare earth-doped amplifier, a semiconductor amplifier, or a combination of these or other types of amplifiers. Amplifier **43** can be selected, for example, to offset losses associated with distributing signals through star switching fabric **40** and/or to provide unity gain for bypass traffic traversing router **12**.

[0081] Wavelength-based switching fabric **40a** also includes a cascade of splitters **45**. Cascade of splitters **45** is operable to receive the wavelength division multiplexed signal from amplifier **43** and to split that signal into a plurality of output signals. In a particular embodiment, each splitter in cascade **47** operates to approximately equally split each signal received into two output signals, each comprising substantially the same wavelength set output from wavelength division multiplexer **41**. Multiple wavelength signals are then communicated from the outputs of cascade **47** to output links of the router or back to line cards for further processing.

[0082] In operation, wavelength-based star switching fabric **40a** receives a plurality of signals each having a distinct center wavelength. Some of these signals can be the result of signals generated at line cards within a router, while others may be express traffic designated to pass through the router without electrical processing. Wavelength division multiplexer **41** combines some or all of these wavelengths into a multiple wavelength signal. The multiple wavelength output signal is amplified by amplifier **43** and communicated to a cascade **47** of splitters **45**. Cascade **47** separates the incoming multiple wavelength signal into a plurality of output signals each carrying a substantially similar set of wavelengths as the input signal to the cascade.

[0083] FIG. 4B shows another embodiment of a star switching architecture, in this case a power-based star switching fabric **40b**. Power-based star switching fabric **40b** includes a power combiner **44** operable to receive a plurality of input signals. In this particular example, some or all of the input signals have center wavelengths distinct from other input signals. Power combiner **44** combines the input signals based on their power to create a combined signal carrying all information received at the inputs of power combiner **44**. Power-based star switching fabric **40b** also includes at least one optical amplifier **46** operable to receive the combined signal from power combiner **44**, to amplify that signal, and to communicate the amplified signal to a power splitter **48**. Amplifier **46** may be similar in structure and function to amplifier **43** described with respect to FIG. 4A. Power splitter **48** comprises a device, or combination of devices operable to separate the power combined signal into a

plurality of output signals each containing substantially the same set of wavelengths output by power combiner **44**. Signals output by power combiner **48** may be communicated directly to output links of a router, or may be communicated to line cards for additional processing.

[0084] To resolve contention between signals competing for the same system resources, it is helpful to implement a scheduling mechanism for use with star switching fabrics. Although complex scheduling mechanisms can be implemented without departing from the scope of the invention, the following figures address relatively simple scheduling mechanisms that can be implemented in conjunction with any star switching fabric, including those described herein. These scheduling mechanisms provide adequate contention resolution capabilities while utilizing minimum processing resources.

[0085] FIG. 5a is a block diagram showing one example of a scheduling mechanism **300** useful in conjunction with any star switching fabric. This example depicts scheduling mechanism **300** operating within router **112** shown in FIG. 2. Scheduling mechanism **300** could, however, be useful with any router or switch using a star switching fabric. In this particular example, scheduling mechanism **300** includes a scheduling star switching fabric **340** configured to receive input signals **252**. Signals received at inputs to scheduling star switching fabric **340** comprise a non-uniform load distribution, where some inputs receive more traffic than others. In a particular example, each input to scheduling star switching fabric **340** is associated with a particular wavelength and operates to receive traffic corresponding to the associated wavelength. In one particular example, each of the inputs to scheduling star switching fabric **340** may receive input optical router signals from an associated line card **230**.

[0086] Scheduling star switching fabric **340** communicates signals **235** to a transmission star switching fabric **240**. Transmission star switching fabric **240** communicates output router signals **254** toward line cards **230** and/or output links **228** from router **112**. Scheduling star switching fabric **340** facilitates creating a more uniform load distribution of wavelength signals at the input to transmission star switching fabric **240** compared to the load distribution received at scheduling star switching fabric **340**. Scheduling star switching fabric **340** helps to more evenly distribute the traffic load across the inputs to transmission switching fabric **340** to allow scheduling of communication through switching fabric **240** using a relatively trivial scheduling algorithm.

[0087] Scheduling mechanism **300** includes one or more scheduling engines **364**. Scheduling engine **364** comprises any hardware, software, firmware, or combination thereof operable to instruct operation of tunable switching elements, such as tunable transmitters or tunable filters, within router **112**. In this particular example, scheduling engine **364** communicates control signals to a plurality of tunable filters **348** in scheduling star switching fabric **340** and to a plurality of tunable filters **248** in transmission star switching fabric **240**. Although this example illustrates a single scheduling engine communicating with filters **248** and filters **348**, separate scheduling engines could be implemented.

[0088] Scheduling engine **364** executes a scheduling algorithm to determine the order in which filters **248** and **348** will be operated and the center wavelength to which each filter



will tune. In this particular example, scheduling engine 364 executes a trivial control algorithm, such as a round robin algorithm. A round robin scheduling algorithm is simple to implement and requires minimal system resources for execution. Round robin scheduling algorithms exhibit good throughput for approximately uniform traffic patterns. A single stage round robin scheduling scheme used in combination with a star switching fabric can, however, experience a 1/N delay when confronted with N channels of non-uniform traffic.

[0089] One embodiment overcomes this difficulty by using one or more initial scheduling stages of scheduling star switching fabric to establish more uniform traffic at the inputs to a transmission star switching fabric 240. In particular, scheduling engine 364 instructs each of filters 348 to tune to alternating wavelengths so that no one of the outputs from scheduling star switching fabric 340 overwhelms transmission star switching fabric 240 with any particular wavelength signal. For example, on a first pass, each of filters 348a-348n may communicate in round robin fashion optical router signals 245 having wavelengths  $\lambda_1$ - $\lambda_n$ , respectively. On a second pass, each of filters 348a-348n-1 may communicate in a round robin fashion optical router signals 245 having wavelengths  $\lambda_2$ - $\lambda_n$ , respectively, while filter 348n communicates signal 245 having wavelength  $\lambda_1$ . Filters 348a-348n can continue to cycle through wavelengths  $\lambda_1$ - $\lambda_n$  so that the wavelength signals 245 are more uniformly distributed to the input of transmission star switching fabric 240. Although the illustrated embodiment depicts a single stage of scheduling star switching fabric, multiple scheduling star switching fabrics could be cascaded to further normalize the load distribution entering transmission switching fabric 240.

[0090] Establishing a more uniform traffic pattern at the input of transmission star switching fabric 240 allows the use of a round robin algorithm to control filters 248 associated with transmission star switching fabric 240 without the 1/N delay penalty. Thus, scheduling mechanism 300 provides a way to schedule non-uniform traffic, such as packet traffic, using a trivial scheduling algorithm for the transmission fabric, which occupies minimal system resources while avoiding 1/N delay penalties traditionally associated with simple routing algorithms and non-uniform traffic.

[0091] Numerous modifications can be made to the example discussed with respect to FIG. 5a. For instance, this example shows tunable filters 248 and 348 as residing in close proximity to or integrally to their respective switching fabrics 240 and 340. This provides an advantage of saving space, for example, on line cards in router 112. Moreover, this technique provides an advantage of facilitating the economical use of arrays of filters rather than individually packaged filters for each output link. Filters 248 and 348 could, however, reside remotely from switch fabrics 240 and 340.

[0092] In addition, although this example shows the use of tunable filters 248 and 348, tunable optical transmitters could alternatively be used in conjunction with fixed wavelength or tunable wavelength filters 248 and/or 348. FIG. 5b is a block diagram illustrating an example embodiment of a scheduling mechanism 305 implementing tunable optical transmitters as selecting elements for the scheduling star switching fabric.

[0093] Scheduling mechanism 305 includes a plurality of tunable optical transmitters 346a-346n, which feed into scheduling star switching fabric 340. Each tunable optical transmitter could reside, for example, on a line card within router 112. Scheduling mechanism 305 also includes a plurality of filters 348a-348n. In this particular example, filters 348 comprise fixed wavelength filters, each associated with a particular center wavelength. Filters 348, in this example, reside within scheduling star switching fabric 340. Filters 348, however, could reside remotely from switching fabric 340.

[0094] In this embodiment, outputs of filters 348 are coupled to inputs of a transmission star switching fabric 240. Transmission star switching fabric 240 is associated, in this example, with a plurality of tunable filters 248a-248n, each associated with an output link 254a-254n from the router.

[0095] Scheduling mechanism 305 further includes one or more scheduling engines 364. Scheduling engine 364 instructs selecting elements 346 and 248 as to the order of tuning and the center wavelength appropriate for tuning. Although a single scheduling engine 364 is depicted, separate engines could be implemented for elements 346 and 248.

[0096] In operation, tunable optical transmitters 346a-346n generate optical signals 252a-252n having center wavelengths determined by scheduling engine 364. Scheduling star switching fabric receives signals 252a-252n and communicates substantially similar sets of at least some of those signals to each of filters 348. In this example, each filter comprises a fixed wavelength filter operable to pass signals having a particular center wavelength.

[0097] Signals 235 passed by filters 348 are then communicated to transmission star switching fabric 240. tunable filters 248 of transmission star switching fabric 240 tune to receive selected wavelengths according to instructions from scheduler 364. As a result, selected wavelength signals are passed from transmission star switching fabric 240 to output links 254.

[0098] FIG. 5c is a block diagram illustrating another example of a scheduling mechanism 310 useful in conjunction with any star switching fabric. Like the example shown in FIG. 5a, this example depicts scheduling mechanism 310 operating within router 112 shown in FIG. 2. Scheduling mechanism 310 could, however, be useful with any router or switch using a star switching fabric. Scheduling mechanism 310 is similar in structure and function to scheduling mechanism 310 shown in FIG. 5a.

[0099] Scheduling mechanism 310 implements a buffering stage 230 between scheduling star switching fabric 340 and transmission star switching fabric 240. Buffering stage 230 facilitates synchronization and aids in scheduling communications between scheduling star switching fabric 340 and transmission star switching fabric 240. As a particular example, buffering stage 230 could comprise a plurality of line cards, each associated with an input to transmission star switching fabric 240. Buffering stage 230 may also include memory used to avoid missequencing of packets received by and communicated from scheduling star switching fabric 340.

[0100] In this example, scheduling switching fabric 340 receives the multiple wavelength signal from input link 222

and communicates separate wavelength signals **228a-228n** (along with any express traffic **228ex**) from switching fabric **340**. In the illustrated embodiment, wavelength signals **228a-228n** are communicated to line cards **230** for buffering and/or electronic decision making with respect to routing those signals through switching fabric **240**. Transmission star switching fabric **240** receives input router signals **252a-252n** and communicates those signals toward destination elements associated with those signals.

[0101] Scheduling switching fabric **340** operates to separate the multiple wavelength signal received at input **222** into a plurality of wavelength signals each having a center wavelength. In this particular example, Scheduling switching fabric **340** includes or is closely coupled to a plurality of tunable filters **348a-348n**, and **348ex**. Tunable filters **348** selectively pass wavelength signals **228a-228n** toward transmission star switching fabric **240**. In this particular embodiment, scheduling star switching fabric **340** passes selected signals **228** to line cards **230** for processing.

[0102] Like the example in FIG. **5a**, scheduling engine **364** operates to provision tunable filters **348a-348n** in a round-robin fashion so that each filter **348** alternates the wavelength it passes toward transmission star switching fabric **240**. In this manner, scheduling switching fabric **340** operates to make non-uniform traffic received at input **222** more uniform at the inputs to transmission star switching fabric **240**. Because the incoming signals **252a-252n** to switching fabric **240** are more uniform in load distribution, scheduling mechanism **310a** can ensure reasonable throughput through switching fabric **240** while utilizing a relatively simple scheduling algorithm, such a round-robin scheduling algorithm.

[0103] The particular embodiment shown in FIG. **5c** is just one example of an implementation of scheduling mechanism **310** in an optical router. Various modifications can be made without departing from the scope of this aspect of the invention. For example, rather than using tunable filters in both switching fabrics **240** and **340**, tunable lasers could be implemented in conjunction with fixed or tunable filters to achieve similar operational effects. For example, line cards **230** could include tunable lasers operable to selectively communicate optical router signals **252a-252n** at selected wavelengths to fixed wavelength transmitters **248a-248n** associated with particular output links from router **112**.

[0104] Moreover, although this example shows filters **248** and **348** as residing integrally to or in close proximity with switching fabrics **240** and **340**, respectively, filters **248** and/or **348** could alternatively reside remotely from their associated switching fabrics. In one particular example, filters **248** and/or **348** could reside on line cards associated with those filters, or in another location remote from their associated switching fabrics.

[0105] As another example of a potential modification to the embodiment shown in FIG. **5c**, processing capabilities and look-up tables of line cards **230** could be eliminated, while electronic or optical memory structures resident on the line cards could remain. These memory structures could serve as buffers to optical signals received from scheduling switching fabric **340** and awaiting transmission to transmission switching fabric **240**. These buffers could further enhance the uniformity of wavelengths communicated to star switching fabric **240**.

[0106] FIG. **5d** is a block diagram showing yet another example of a scheduling mechanism **320** useful in conjunction with any star switching fabric. Like the example shown in FIGS. **5a-5c**, this example depicts a scheduling mechanism **320** operating within router **112** shown in FIG. **2**. Scheduling mechanism **320** could, however, be useful with any router or switch using a star switching fabric.

[0107] Scheduling mechanism **320** is similar in structure and function to scheduling mechanism **320** shown in FIG. **5c**. Scheduling mechanism **320**, however, implements an input buffer stage **330** operable to receive wavelength signals from a wavelength division multiplexer **325** and an output buffer stage **332** operable to receive wavelength signals **254** output from transmission star switching fabric **240**.

[0108] Input buffer stage **330** facilitates segmentation, synchronization, buffering, and/or scheduling of communications to scheduling star switching fabric **340**. Input buffer stage **330** could comprise any hardware, software, firmware, or combination thereof operable to facilitate storage and retrieval of signals received. In some embodiments, input buffer stage **330** could comprise an optical memory comprising, for example, one or more delay loops. In other embodiments, input buffer stage could comprise an electronic memory. Input buffer stage **325** could reside, for example on one or more line cards operable to convert at least a portion of incoming optical signals to an electronic format and to generate optical signals for retransmission to scheduling switching fabric **340**. In one particular embodiment, input buffer stage **325** could reside on line cards **230**.

[0109] Input buffer stage **325** can facilitate creating an even more uniform load distribution of wavelength signals at the input to star switching fabric **240**. Moreover, input buffer stage **325** can provide a mechanism to help alleviate missequencing of packets at the outputs from star switching fabric **240**. This technique can be particularly effective when used in combination with a Full Frames First algorithm to control the buffers in the system.

[0110] In operation, scheduling mechanism **320** receives at wavelength division multiplexer **325** a multiple wavelength input signal from input link **222**. Wavelength division multiplexer **325** separates the multiple wavelength input signal into a plurality of optical signals, each having a center wavelength. Input buffer stage **325** stores incoming wavelength signals until those signals are communicated toward scheduling switching fabric **340**. Switching fabric **340** communicates substantially similar sets of some or all of the wavelength signals received to filters **348**.

[0111] In this example, filters **348** comprise tunable filters residing in close proximity to or integrally with switching fabric **340**. Scheduling engine **364** instructs each of filters **348a-348n** in a round robin fashion to alternately communicate signals having various selected wavelengths. This reduces the nonuniformity of wavelengths of incoming signals.

[0112] Transmission star switching fabric **240** receives input router signals **252** having a more uniform load distribution, and communicates substantially similar sets of some or all of the wavelength signals received to filters **248**. Each of filters **248** is provisioned in a round robin fashion to pass selected wavelength signals toward output links associated with appropriate destination elements.

[0113] As in the examples described in FIGS. 5a-5c, the example shown in FIG. 5d could be modified in any number of ways. For example, tunable optical transmitters could be used in place of some or all of the tunable filters implemented. Moreover, filters 248 and 348 could reside remotely from their associated switching fabrics.

[0114] Each of the embodiments of scheduling mechanisms depicted in FIGS. 5a-5d provides a way to provide adequate throughput through switching fabric 240 while utilizing a relatively simple scheduling algorithm.

[0115] FIGS. 6a-6d provide additional nonlimiting examples of implementations of scheduling mechanisms useful with star switching fabrics. FIG. 6a is a block diagram showing an example of a multiple buffer embodiment 315 utilizing tunable optical filters as selecting elements within a scheduling star switching fabric. In particular, embodiment 315 includes a plurality of line cards 230 which serve as an input buffer stage 230a, an intermediate buffer stage 230b, and an output buffer stage 230c. Although this embodiment depicts the use of different sets of cards 230a-230c to serve as input, intermediate, and output buffer stages, the same set of line cards could likewise be used for some or all of the buffer stages, or one or more buffer stages could be eliminated.

[0116] In this example, input buffer stage 230a operates to segment incoming information into, for example, fixed length frames or cells for transmission through transmission switching fabric 240. Input buffer stage 230a can also perform a temporary storage function while packets are scheduled for transmission through scheduling star switching fabric 340.

[0117] In the illustrated embodiment, scheduling star switching fabric 340 comprises or is coupled to a plurality of tunable optical filters 348a-348n, each associated with an output from scheduling star switching fabric 340. Under the control of a scheduling engine 364 (located, for example, on one or more line cards 230), tunable filters 348a-348n tune, in a round robin fashion, to particular wavelengths to be transmitted toward the inputs of transmission star switching fabric 240. Scheduling engine 364 instructs each filter 348 to alternate the wavelength of information communicated so that the inputs to transmission star switching fabric 240 experience a more uniform traffic load than the inputs to scheduling star switching fabric 340.

[0118] In this example, optical transmitters associated with each line card 230b generate input optical router signals 252 at particular wavelengths associated with each line card 230b. Signals 252 are communicated to transmission star switching fabric 240, where substantially similar sets of at least some of input optical router signals 252 are communicated to each of a plurality of tunable filters 248a-248m, each associated with an output link from the device. Processors on or associated with line cards 230b perform electronic decision making on signals 228 received to determine an appropriate path for each signal from transmission star switching fabric 240. Based on this determination, the processors instruct tunable filters 248 to tune to particular wavelengths so that signals destined for the output link associated with that tunable filter 248 are passed by that filter.

[0119] Because scheduling star switching fabric 340 has created a more uniform traffic distribution at the inputs of

transmission star switching fabric 240, the scheduling engine that schedules communication through transmission star switching fabric 240 can implement a trivial scheduling algorithm, such as a round robin algorithm, to effectively administer system resources.

[0120] FIG. 6b is a block diagram of an example multiple buffer embodiment 316 utilizing tunable optical transmitters 346 as selecting elements within a scheduling star switching fabric 340.

[0121] Embodiment 316 includes a plurality of line cards 230 which serve as an input buffer stage 230a, an intermediate buffer stage 230b, and an output buffer stage 230c. Buffer stages 230a-230c can serve similar functions to like stages described above with respect to FIG. 6a. Although this embodiment depicts the use of different sets of cards 230a-230c to serve as input, intermediate, and output buffer stages, the same set of line cards could likewise be used for some or all of the buffer stages, or one or more buffer stages could be eliminated.

[0122] In the illustrated embodiment, scheduling star switching fabric 340 comprises or is coupled to a plurality of tunable optical transmitters 346a-346n, each associated with an input to scheduling star switching fabric 340. Under the control of a scheduling engine 364 (located, for example, on one or more line cards 230), tunable transmitters 346a-346n tune, in a round robin fashion, to particular wavelengths to be transmitted toward the inputs of scheduling star switching fabric 340. Scheduling engine 364 instructs each transmitter 346 to alternate the wavelength of information communicated so that the inputs to transmission star switching fabric 240 (received from outputs of scheduling star switching fabric 340) experience a more uniform traffic load than the inputs to scheduling star switching fabric 340.

[0123] Scheduling star switching fabric 340 receives the plurality of incoming signals and communicates substantially similar sets of at least some of the signals received to each of a plurality of fixed wavelength filters 348a-348n. Each filter 348 is tuned to a particular wavelength and communicates signals 228 having the associated wavelength to an associated one of line cards 230.

[0124] Processors on or associated with line cards 230b perform electronic decision making on signals 228 received to determine an appropriate path for each signal from transmission star switching fabric 240. In this example, each line card 230 includes or is associated with a tunable optical transmitter 246a-246n, respectively. Tunable optical transmitters 246 tune to selected wavelengths under the direction of scheduling engine 364 executed by the processors. Scheduling engine 364 instructs each tunable transmitter 246 to tune, in a round robin fashion, to a particular wavelength. Signals are communicated from tunable transmitters 246 to transmission star switching fabric 240, which communicates a substantially similar set of at least some of the signals received toward each of a plurality of fixed wavelength filters 248 within or coupled to transmission star switching fabric 240. The wavelength selected for each transmitter will determine the output link over which the generated signal will pass, as each of the fixed wavelength filters 248 passes a wavelength associated with a particular output link associated with that filter.

[0125] Because scheduling star switching fabric 340 has created a more uniform traffic distribution at the inputs of

transmission star switching fabric **240**, the scheduling engine that schedules communication through transmission star switching fabric **240** can implement a trivial scheduling algorithm, such as a round robin algorithm, to effectively administer system resources.

[0126] FIG. *6c* is a block diagram showing yet another embodiment **317** of a multiple buffer stage switching fabric using tunable optical filters as selecting elements.

[0127] This embodiment is similar in structure and function to the embodiment depicted in FIG. *6a*, but introduces input signals directly to scheduling star switching fabric **340** without an input buffer stage preceding scheduling star switching fabric **340**.

[0128] FIG. *6d* is a block diagram showing yet another embodiment **318** of a multiple buffer stage switching fabric using tunable optical filters as selecting elements.

[0129] This embodiment is similar in structure and function to the embodiment depicted in FIG. *6c*, but implements a power combiner **333** in place of wavelength division multiplexers **210** shown in FIGS. *6a-6c*. In addition, this embodiment can use one or more optical amplifiers **337** prior to the input to scheduling star coupler **340**. Optical amplifiers **337** operate to compensate for at least a portion of the loss otherwise caused by power combiner **333**.

[0130] As discussed above, various embodiments of devices implementing star switching fabrics implement optical transmitters to generate signals destined for the star switching fabric. Some embodiments described herein have discussed implementing optical transmitters having fixed or tunable wavelength capabilities on line cards within the devices. As the number of channels serviced by the system increases, difficulties can arise with respect to implementation of conventional optical transmitter technology.

[0131] For example, implementing a conventional laser diode on each line card servicing a transmission channel can be prohibitively expensive as the number of channels become large. Moreover, conventional lasers and associated control circuitry can take up significant space on each line card, leaving less space for other processing elements, or requiring larger line cards. Requiring larger line cards typically reduces the number of cards that can be placed in any given rack.

[0132] In addition, as the number of channels increases, it becomes increasingly difficult to administrate accurate assembly of line cards using fixed wavelength transmitters. In that case, it becomes necessary to ensure that each line card receives a transmitter operating at a wavelength specified for that card. Increased numbers of channels make it difficult to accurately associate transmitter part numbers with particular line cards.

[0133] Furthermore, as the number of channels increases, the channel spacing typically becomes more narrow. It becomes increasingly difficult to stabilize the wavelength of each individual transmitter to ensure proper channel spacing.

[0134] FIG. *7* is a block diagram of an optical transmitter system **380** particularly useful, for example, in conjunction with a star switching fabric implementing large number of channels, for instance 64 or more channels. Optical transmitter system **380** comprises a continuum source. In a

particular embodiment, system **380** could comprise a super-continuum source. Supercontinuum generation describes extreme, nearly continuous spectral broadening induced by high-intensity picosecond and sub-picosecond pulse propagation through a nonlinear medium.

[0135] In this example, system **380** includes a modelocked source **382** operable to generate a series of optical pulses. As a particular example, modelocked source **382** could comprise an erbium doped fiber laser operable to generate pulses at a rate of, for example, forty gigabits per second. Other modelocked sources operating at other rates could likewise be used.

[0136] System **380** further includes a continuum generator **384** operable to receive a train of pulses from modelocked source **382** and to spectrally broaden the pulses to form an approximate spectral continuum of optical signals. In this example, continuum generator **384** includes an optical amplifier **383** coupled to one or more lengths of optical fiber **385**. Optical amplifier **383**, in this particular example, comprises an erbium doped amplifier. Other amplifier types or combinations of amplifier types could likewise be used. In this example, fiber **385** comprises a two stage solution-effect compressor including approximately two meters of standard fiber followed by approximately two meters of dispersion shifted fiber. Other lengths of fiber and fiber types could be used, depending on the spectral characteristics desired. Moreover, although this example relies on the solution effect to broaden the spectrum of the plurality of optical pulses, other pulse compression techniques, such as adiabatic solution compression, could alternatively be used.

[0137] System **380** also includes a signal splitter **386**. Signal splitter **386** receives the continuum from continuum generator **384** and separates the continuum into individual signals **389a-389n** each having a wavelength or a range of wavelengths. Signal splitter **386** could comprise, for example, a passive wavelength division multiplexer, a power splitter followed by fixed wavelength filters, or any other mechanism operable to separate a continuum or near continuum of signals into a plurality of individual signals.

[0138] Mode locked source **382**, continuum generator **384**, and signal splitter **386** can comprise common bay equipment—in other words, equipment shared by plurality of line cards **390**. Where it is desired to generate a larger bandwidth of optical signals, multiple sets of common bay equipment **381** can be implemented, each set serving a separate set of line cards **390** and each generating a separate range of wavelengths.

[0139] Signal splitter **386** communicates signals **389a-389n** to one of a plurality of modulators **392a-392n**, respectively. Modulators **392** operate to encode information onto the optical signals received to produce optical wavelength signals **393** for transmission to a star switching fabric. In this particular example, each modulator **392** resides on a line card **390**. When used with a continuum source, each of the plurality of transmitters in system **380** can be viewed as one of modulators **392** in combination with equipment, such as common bay equipment **381**, used to generate the unmodulated signal received by each modulator **392**.

[0140] In some embodiments, system **380** further comprises a pulse rate multiplexer **387**, such as a time division multiplexer. Pulse rate multiplexer **387** operates to multiplex

pulses received from mode locked source **382** to increase the bit rate of the system. Pulse rate multiplexer **387** could alternatively reside downstream from modulators **392** and operate to time division multiplex signals received from modulators **392**.

[0141] In operation, modelocked source **382** generates a plurality of optical pulses at a given rate. Continuum generator **384** receives the train of pulses from modelocked source **382** and compresses those pulses to form an approximate continuum of optical signals. Signal splitter **386** receives and separates the continuum into a plurality of optical signals **389a-389n** each comprising a wavelength or range of wavelengths. Each modulator **392** receives one of signals **392** from signal separator **386** and encodes information onto the optical signal received to generate signals **393** for transmission to a star switching fabric.

[0142] Transmitter system **380** can support generation of fixed wavelength signals or selectively tuned wavelength signals. To facilitate generation of selectively tuned wavelength signals, system **380** could include, for example, a signal selector **395** operable to selectively pass particular wavelength signals to particular modulators **393**, depending on the wavelength signal desired to be transmitted from that modulator **393**. Signal selector **395** could comprise any hardware, software, firmware, or combination thereof operable to send particular wavelength signals to particular modulators in response to, for example, a control signal generated by a scheduling engine.

[0143] System **380** provides numerous benefits over systems implementing separate optical transmitters for each channel. For example, implementing one or more common modelocked sources to generate numerous wavelength signals, saves considerable space on each line card, and reduces cost by eliminating numerous individual transmitters. Moreover, system **380** facilitates using common parts, such as modulators, for a number of different line cards serving different channels. This makes it easier to match parts to each line card. Furthermore, stabilization issues can be alleviated because system **380** allows stabilization of one or a few common transmitter elements, rather than requiring stabilization of separate transmitters each associated with one of the channels.

[0144] FIGS. **8-9** are block diagrams illustrating example mechanisms useful enhancing the effective switching speed of devices using star switching fabrics. For the purposes of illustration, these mechanisms will be described with reference to router **112** shown in FIG. **2**. These mechanisms could, however, equally apply to many other device designs implementing star switching fabrics.

[0145] FIG. **8a** illustrates the use of a speed-up mechanism **125** at line card **130**. In this example, line card **130** receives incoming optical signal **128**, which includes packets having a first duration, say fifty nanoseconds each. Each optical packet **128** is converted to an electronic signal within line card **130** and then placed into an optical format **152** for transmission to the router switching fabric.

[0146] Speed-up mechanism **125** of line card **130** operates to decrease the duration of each optical packet **128**. For example, speed-up mechanism **150** may increase the speed at which a modulator of line card **130** encodes information onto optical signal **152**. As a particular example, information

can be modulated onto optical signal **152** at an increased rate resulting in the information received in optical signal **128** being modulated in an optical signal **152** having one half the duration of signal **128**. Other speed-up ratios could be used without departing from the scope of the invention.

[0147] FIG. **8b** is a block diagram showing one example of an aggregator **135** operable to aggregate a plurality of incoming packets **131** into a single aggregated frame **137**. Each aggregated frame includes an identifier identifying a destination element common to each packet **131** in the aggregated frame **137**. Aggregator **135** can aggregate multiple packets **131**, for example, by encapsulating a plurality of packets within a single aggregation frame having a common aggregation header.

[0148] Aggregator **135** can assemble aggregated frames **137** in a variety of ways. For example, aggregator **135** can aggregate optical packets received at line card **130** from input link **128**, associating an identifier with each frame **137**. Line card **130** can then convert at least the identifier portion of the frame **137** to an electronic format to facilitate electronic processing of that information. Line card **130** could then generate an optical aggregation header and reform an aggregated frame for transmission to star switching fabric **140**. As another example, aggregator **135** could form aggregated frames **137** after each packet **131** of that frame or portions thereof are processed by processor **136**. In that case, processor **136** converts all or a portion of each packet received to an electrical signal to facilitate electronic processing. Transmitter **146** forms optical router packets, and aggregator **135** combines optical router packets into aggregated frames **137**.

[0149] Allowing switching fabric **140** to switch a smaller number of larger frames rather than numerous individual packets can provide significant switching efficiencies.

[0150] FIGS. **9a-9c** are block diagrams showing various embodiments of filter and transmitter configurations operable to enhance the effective switching speed of router **12** without modifying the switching speed of any individual components, such as filters **148** or transmitters **146**. In particular, FIG. **9a** is a block diagram of a multiple filter configuration. The speed of router **112** can be limited in some cases by the switching speed of filters **148**. That is, each filter requires some finite time to tune between different wavelengths desired to be processed. If router **112** is forced to wait while filters **148** reset between wavelengths, the speed of router **112** can be significantly hindered.

[0151] The example embodiment in FIG. **9a** helps to alleviate this problem without requiring increased switching speed of any one filter **148**, by assigning a plurality of filters **148a1-148ax** to each optical link **128**. Filters **148a1-148ax** operate in parallel so that while one filter **148a1** is processing output optical router signal **154** from switch fabric **140**, other filters **148a2-148ax** can be retuned to another wavelength to receive packets carried over other channels. By switching between the multiple parallel filters **148a1-148ax**, switching delay that might otherwise be caused when waiting for filters **148** to retune can be significantly reduced.

[0152] In the illustrated embodiment, an optical splitter **141** receives output optical router signal **154** from switch fabric **140** and communicates a portion **154a1-154ax** to each of filters **148a1-148ax**, respectively. In this particular

example, a switch **151** cycles between signals received from filters **148a1-148ax** so that only one of the signals from filters **148a** is output to line card **136**. Although this example shows use of a sequential control algorithm that switches from one filter output to another, a variety of control algorithms can be used to determine an active filter **148a**. For example, switch **151** could receive a control signal instructing switch **151** as to which filter output to accept.

[0153] In the embodiment shown in FIG. **9a**, optical signals output from filters **148a** are converted to electrical signals at receivers **149a**, each associated with one of filters **148a**. Switch **151** operates to process electrical signals received from converters **149a** and to pass an electrical output to an associated line card **136**. The embodiment shown in FIG. **9b** is similar in structure and function to that shown in FIG. **9a**, except that electrical switch **151** is replaced with an optical switch **153**. Optical switch operates to receive optical signals from filters **148a** and to select one of those optical signals for communication to converter **149a**. Converter **149a** converts the selected signal to an electrical signal and passes the converted electrical signal to an associated line card **136**.

[0154] Although the example shown in FIG. **9b** depicts the use of multiple filters per line card **136**, a similar concept could be applied to filters associated with express channels **127**. In that case, converters **149** could be eliminated so that optical signals output from optical switch **153** pass to wavelength division multiplexer/demultiplexer **110** from optical link **127**.

[0155] FIG. **9c** is a block diagram showing yet another mechanism operable to reduce switching delay of router **112** without modifying the switching speed of individual switching components. This example implements a plurality of tunable lasers **146a1-146ax** associated with each line card **136**.

[0156] While one of optical transmitters **146a1-146ax** generates an optical router signal having one particular wavelength, other transmitters **146a2-146ax** can be retuned to another wavelength to communicate packets bound for other destinations. By switching between the multiple parallel transmitters **146a1-146ax**, switching delay that might otherwise be caused when waiting for transmitters **146** to retune can be reduced or avoided.

[0157] In the illustrated embodiment, a splitter **143** receives electrical signal **129a** from processor **136** and communicates a portion **129a1-129ax** to each of transmitters **146a1-146ax**, respectively. At least one of transmitters **146a1** generates an optical router signal at a specified wavelength. Other transmitters **146a2-146ax** can retune without emitting light during the time that active transmitter **146a1** generates the optical signal. For example, where optical transmitters **146** comprise multiple stage lasers including tuning stages and lasing stages, the lasing stages of those transmitters can remain inactive while tuning stages adjust to process a new wavelength.

[0158] A switch **155** selects an appropriate optical router signal from lasers **146a** and communicates that signal to switching fabric **140**. In one embodiment, switch **155** can sequentially cycle between signals received from transmitters **146a1-146ax**. A variety of control algorithms can be used to determine an active transmitter **146a**. For example,

switch **155** could receive a control signal instructing switch **155** as to which transmitter output to accept and communicate to switch fabric **140**.

[0159] Each of the efficiency enhancing mechanisms described with respect to FIGS. **4** and **5** could be used independently or in combination with one, some, or all others of those mechanisms to further enhance operation of the router.

[0160] FIG. **10** is a flow chart illustrating one example of a method **400** of routing optical signals. For the purposes of illustration, method **400** will be described with reference to router **112** shown in FIG. **2**. Method **400**, however, could equally apply to alternative router designs, such as router **212** shown in FIG. **3** including enhancements shown in FIGS. **8** and/or **9**. Method **400** begins at step **405** where line card **130a** receives a first packet **128a** comprising an identifier of a destination element.

[0161] Processor **136a** of line card **130a** converts at least the identifier portion of first packet **128a** to an electronic format. Processor **136a** applies the identifier to look-up table **144a** to determine control signal **162a** at step **410**. In this example, control signal **162a** instructs a particular tunable filter, for example, filter **148n** to tune to a wavelength transmitted by transmitter **146a** of first line card **130a**. Alternatively, processor **136a** could communicate control signal **162** to scheduling engine **164** to facilitate scheduling and arbitration among control signals **162** before transmitting those signals to filters **148**.

[0162] The identification of a destination tunable filter **148** could comprise identification of a plurality of tunable filters operating in parallel to service a single optical link and/or line card. Embodiments discussed with respect to FIGS. **9a-9b** provide examples of this type of operation. In this manner, one of the filters **148** can process the optical signal while other filters in that group retune to or from other wavelengths. This can help to enhance the effective switching speed of router **112**.

[0163] Transmitter **146a** generates an optical router signal **152a** and communicates that signal to star coupler switch fabric **140** at step **415**. In a particular embodiment, transmitter **146a** comprises a fixed wavelength transmitter operable to generate optical router signal **152a** at a particular fixed wavelength. Generating optical router signal **152** could comprise, for example, generating optical router signal **152** using a laser/modulator combination residing on the same line card. In another example, a modulator **393** resident on line card **130a** could receive from common bay equipment (see e.g., FIG. **7**) an unmodulated optical signal having a particular wavelength. Modulator **393** could modulate information onto the unmodulated signal to generate optical router signal **152**.

[0164] The process by which transmitter **146a** generates optical router signal **152a** depends, in part, on the level of conversion experienced by incoming packet **128a**. Where processor **136a** converts the entire optical signal **128a** into an electronic format, transmitter **146a** information for the entire optical signal including header and payload information for optical router signal **152a**.

[0165] Where, on the other hand, processor **136a** converts only a portion of optical signal **128a**, transmitter **146a** merely converts that portion of the signal back to an optical

signal, and recombines that portion with the original optical portion of signal **128a** to form optical router signal **152a**. As a particular example, processor **136a** may convert only a header portion, or only the identifier portion of a header portion of signal **128a** to an electronic format, while temporarily storing or delaying the remainder of optical signal **128a** until it can be combined with an optical signal leaving transmitter **146a**.

[0166] Generation of optical router signal **152a** may include aggregating individual packets **131** into larger frames **133** and/or may include reducing the duration of each packet by implementing a speed-up mechanism such as that described with respect to FIG. **8a**.

[0167] Star coupler switching fabric **140** receives the first optical router signal **152a** and at least one other optical router signal **152b** having a wavelength that is different than first optical router signal **152a**, and communicates both optical router signals **152a** to a plurality of tunable filters **148** at step **420**. In this example, tunable filter **148n** is associated with a line card coupled to an optical path facilitating communication with the destination network element. In this case, router **112** communicates control signal **162** to tunable filter **148n** at step **425**.

[0168] Based at least in part on control signal **162a**, filter **148n** associated with line card **130n** tunes to the wavelength associated with optical router signal **152a**.

[0169] As a result, filter **148n** accepts the first packet carried by optical router signal **152a** at step **430** and facilitates communication of the first packet toward the destination element. Tunable filter **248n** comprises a tunable optical filter operable to selectively accept one or more specified wavelengths while rejecting others. Filter **148n** may communicate the first packet toward the destination element without further conversion, or may pass optical router signal **152a** to an optical-to-electrical converter **149n** to facilitate additional processing before communicating the first packet toward the destination network element.

[0170] FIG. **11** is a flow chart showing one example of a method **350** of scheduling communications through a star switching fabric. Method **350** will be described with respect to scheduling mechanism **300** shown in FIG. **5a**. Method **350** could apply, however, to any scheduling mechanism described herein.

[0171] Method **350** begins at step **355**, where scheduler **300** receives a plurality of packets having a first load distribution. Scheduler **300** could receive, for example a plurality of packets in an optical format, where each packet is associated with a wavelength. Typically, packet-based traffic will exhibit a non-uniform load distribution.

[0172] In this particular example, scheduling star switching fabric **340** of scheduler **300** receives packets **252a-252n**, and communicates a substantially similar set of at least some of packets **252** toward each of a plurality of filters **348** at step **360**. In this example, filters **348** each comprises a tunable filter operable to selectively tune to a wavelength to be passed. Alternatively, filters **348** could comprise fixed-wavelength filters used in combination with tunable wavelength optical transmitters, such as transmitters **346** shown in FIG. **5b**.

[0173] Scheduler **300** selectively passes packets associated with selected wavelengths for receipt by transmission

star switching fabric **240** at step **365**. In this example, under the direction of scheduling engine **364**, filters **348** selectively tune to alternating wavelengths in a round robin fashion to ensure that no one particular wavelength overwhelms transmission switching fabric **240**. The result of the selective alternate tuning of filters **348** culminates in a more uniform load at the input to transmission star switching fabric **240**.

[0174] As a result, scheduler **300** schedules communication of packets from transmission switching fabric **240** at step **370** using a trivial scheduling algorithm. Scheduler **300** may implement, for example, a round robin algorithm for scheduling tuning of selectable elements, such as filters **248**, associated with transmission star switching fabric **240**. By establishing a more uniform load at the input to transmission star switching fabric **240**, scheduler **300** avoids the 1/N delay penalty that would otherwise be associated with using a trivial scheduling algorithm on non-uniform traffic.

[0175] FIGS. **12-16** are flow charts illustrating example methods of enhancing the effective switching speed of a router utilizing a star switching fabric without increasing switching speed of the individual switching components of the router. For brevity of description, the following methods will be described with reference to router **112** depicted in FIG. **2**. The methods described with respect to FIGS. **12-16** could, however, apply to any router design utilizing a star switching fabric, and are not intended to be limited only to the example router embodiments explicitly described herein.

[0176] FIG. **12** is a flow chart illustrating one example of a method **450** of enhancing the effective switching speed of router by reducing the duration of packets communicated through a star switching fabric of the router. Method **450** begins at step **455** where router **112** receives at a first line card **130** an optical packet comprising a payload and having a first duration. Referring to FIG. **8a**, optical packet **131** may comprise a duration of, for example, 50 nanoseconds. Line card **130** generates at step **460**, an optical router packet **133** having a second duration shorter than the first duration. Optical router packet **133** comprises the payload of optical packet **131** received by line card **130**, and comprises a second duration shorter than the first duration associated with packet **131**. In this particular example, the second duration of packet **133** comprises approximately one half the duration of input packet **131**.

[0177] Line card **130** communicates the optical router packet **133** to star switching fabric **140** at step **465**. Star switching fabric **140** communicates at step **470** a plurality of optical router packets to each of a plurality of tunable filters **148**. Each tunable filter **148** is associated with a separate output link from router **112**. Router **112** communicates at step **475** a control signal **162** to a selected tunable filter **148** to facilitate communicating at least the payload of the optical router packet **133** toward the destination element associated with that packet. The control signal **162** causes tunable filter **148** to tune to a wavelength associated with optical packet **133**, and to substantially communicate packet **133** toward a destination element associated with that optical filter **148**. Prior to communicating optical packet **133** from router **112**, router **112** may expand the duration of packet **133** to recover its original duration.

[0178] By reducing the duration of packets received at line cards **130**, router **112** can increase switching speed and

throughput associated with the router without modifying the switching speeds of any particular switching components in router 112.

[0179] FIG. 13 is a flow chart showing one example of a method 500 of enhancing the effective switching speed of an optical router by aggregating packets bound for a common destination element. Method 500 begins at step 510 where router 112 receives a plurality of optical packets each comprising a payload and each comprising an identifier of the same destination element. Referring to FIG. 8*b*, router 112 generates at step 520 an aggregated frame 137 comprising an identifier 139 of the destination element shared by packets 131*a*-131*n*.

[0180] Router 112 communicates at step 530 aggregated frame 137 to star switching fabric 140. In this example, star switching fabric 140 communicates at step 540 aggregated frame 137 to each of a plurality of tunable filters 148. Each tunable filter is associated with a separate output link from router 112. Alternatively, aggregated frames 137 could be generated by tunable optical transmitters and communicated to a plurality of fixed wavelength filters through star switching fabric 140.

[0181] In the illustrated example, router 112 communicates a control signal to at least a selected tunable filter 148 at step 550. The selected tunable filter 148 is associated with a communication path to a destination element for each of the optical packets 131*a*-131*n* within aggregated frame 137. The selected tunable filter 148 receives a control signal and tunes to a wavelength associated with aggregated frame 137, facilitating communication of aggregated frame 137 toward the destination element. A line card 130 associated with the output link 128 leading to the destination element may disassemble aggregated frame 137 to facilitate communication of individual packets 131*a*-131*n* toward the destination element.

[0182] FIG. 14 is a flow chart showing one example of a method 600 of enhancing the effective switching speed of an optical router using a star switching fabric by providing express lanes that bypass line cards that facilitate electronic signal processing of some of the optical signals received. Method 600 begins at step 610 where router 112 receives an input optical packet at optical link 128. A line card 130 converts at least a portion of the optical packet received to an electronic form at step 620. Line card 130 generates, based at least in part on the electronic signal, an optical router signal having a first wavelength at step 630.

[0183] Router 112 also receives at an express lane 127 an express optical packet having a second wavelength at step 640. Router 112 communicates at step 650 the optical router packet generated at line card 130 and the express packet received at express lane 127 to star switching fabric 140. Star switching fabric 140 communicates the optical router packet and the express packet to each of a plurality of tunable filters at step 660. Router 112 communicates a control signal to a selected tunable filter at step 670 to facilitate communicating the express optical packet toward a destination element associated with that filter. The express optical packet is communicated from an input to router 112, through switching fabric 140, to an output of router 112 without ever having been converted to an electronic form. Facilitating bypassing line cards 130 depending, for example, on the wavelength of the optical packets received,

can provide significant efficiencies. Packets that do not require electronic processing can transparently pass through router 112, saving system resources and reducing delay that would otherwise accompany having to convert all packets received between optical and electrical formats.

[0184] Again, although this example discusses the use of tunable filters and fixed wavelength transmitters, the concepts also apply to embodiments utilizing tunable optical transmitters and fixed wavelength filters.

[0185] FIG. 15 is a flow chart showing one example of a method 700 for enhancing the effective switching speed of an optical router using a star switching fabric by assigning a plurality of tunable filters to each output link from the router. Method 700 begins at step 710 where router 112 receives at star switching fabric 114 a plurality of optical signals each having a wavelength. Although some of the optical signals may have the same wavelengths, at least some of the signals received have different wavelengths from other signals received. Star switching fabric 140 communicates at step 720 a plurality of substantially similar sets of the optical signals. In some embodiments, each of the substantially similar sets of optical signals may comprise a combination of all signals received by the star switching fabric 140. In other embodiments, star switching fabric 140 may communicate only some of the optical signals received.

[0186] A group of tunable filters 148 associated with a common output from router 112 receives one of the plurality of substantially similar sets of optical signals at step 730. Referring for example to FIG. 9*a*, a first tunable filter 148*a*1 of the group of tunable filters associated with the output link is tuned to a first wavelength to process one of the optical signals received having primarily the first wavelength at step 740. While the first filter 148*a*1 processes the optical signal primarily comprising the first wavelength, a second tunable filter 148*a**n* of the same group tunes to a second wavelength at step 750. In a particular embodiment, the second tunable filter 148*a**n* can substantially complete tuning to the second wavelength before the first tunable filter 148*a*1 completes processing the optical signal having primarily the first wavelength.

[0187] Router 112 communicates the optical signal having primarily the first wavelength from first tunable filter 148*a*1 to an output link associated with that filter at step 760. Subsequently, the group of tunable filters, and in particular, second tunable filter 148*a**n* tuned to the second wavelength may receive another set of optical signals and facilitate communication of an optical signal comprising primarily the second wavelength toward the output link associated with that group of filters.

[0188] Assigning a plurality of tunable filters to a single output link allows router 112 to conceal delay that would otherwise be associated with having to retune filters to process different wavelength signals. Using a multiple filter configuration, router 112 can conceal delay by reconfiguring one filter associated with the output link while another filter associated with that same output link processes signals being received.

[0189] FIG. 16 is a flow chart showing one example of a method 800 of reducing delay by assigning a plurality of tunable transmitters to an input link to the router. In this example, method 800 begins at step 810 where a first tunable



transmitter of a group of tunable transmitters associated with a single input to the router generates an optical router signal having primarily a first wavelength. Referring to FIG. 8c for exemplary purposes, while first transmitter 146a1 generates the optical router signal having primarily the first wavelength, a second tunable transmitter 146an tunes to a second wavelength at step 820. In a particular embodiment, second tunable transmitter 146an substantially completes tuning to the second wavelength before first tunable transmitter 146a1 completes generation of the first optical router signal. This process can be repeated at multiple groups of tunable transmitters, each group associated with one input to router 112.

[0190] Router 112 communicates at step 830 a signal from each of the groups of tunable transmitters to star switching fabric 140. Star switching fabric 140 communicates substantially similar sets of optical signals received to each of a plurality of filters. In this particular example, each of the filters comprises a fixed wavelength filter operable to substantially communicate a predetermined wavelength or range of wavelengths and to reject other wavelengths. Each filter can be associated with an output from router 112. Router 112 can facilitate selectively directing signals through switching fabric 140 by selectively tuning transmitters 146 to wavelengths of filters associated with desired output links from router 112. Like the method implementing multiple tunable filters for each output link, using multiple tunable transmitters for each input link conceals delay otherwise associated with reconfiguring tunable lasers of router 112.

[0191] In various embodiments, one or more switching time enhancing techniques, such as those described in FIGS. 12-16 can be combined to further increase the switching time of the router.

[0192] Although various aspects of the present invention have been described in several embodiments, a myriad of changes, variations, alterations, transformations, and modifications may be suggested to one skilled in the art, and it is intended that the present invention encompass such changes, variations, alterations, transformations, and modifications as fall within the spirit and scope of the appended claims.

1. (canceled)
2. (canceled)
3. (canceled)
4. (canceled)
5. (canceled)
6. (canceled)
7. (canceled)
8. A network operable to direct optical signals, the network comprising:
  - a scheduler engine operable to generate one or more control signals;
  - one or more control lasers coupled to the scheduler engine, each of the one or more control lasers operable to generate an optical control signal based at least in part on a portion of the one or more control signals, wherein the optical control signal comprises at least a portion of information of the one or more control signals;
  - a transmission star fabric coupled to the one or more control lasers, the transmission star fabric operable to

distribute the optical control signal to a first plurality of line cards, each of the first plurality of line cards comprising one or more receivers coupled to an electronic processor and further coupled to one or more transmitters, the one or more receivers adapted to receive the optical control signal, the one or more optical transmitters adapted to communicate one or more optical output signals to the transmission star fabric, wherein the one or more optical output signals are communicated based at least in part on the portion of information of the one or more control signals, and wherein the optical control signal is at a different optical wavelength than at least some of the one or more optical output signals;

wherein the transmission star fabric is operable to combine at least some of the optical output signals into one or more combined optical output signals and to direct at least a portion of the one or more combined output signals to an input buffer;

wherein the one or more control signals generated by the scheduler engine control firing of the one or more transmitters using a scheduling algorithm that operates to avoid collisions between the optical output signals in the transmission star fabric;

wherein the scheduler engine is further coupled to an optical switching fabric that communicates at least some of the information of the at least a portion of the one or more combined output signals with a second plurality of line cards; and

wherein traffic transmitted through the transmission star fabric comprise at least in part an Internet Protocol (IP) or a Transmission Control Protocol (TCP) packet.

9. The network of claim 8, wherein the one or more optical output signals comprise variable length packets, each of the variable length packets comprising a header and a variable length payload.

10. The network of claim 8, wherein the input buffer is further coupled to a wavelength division multiplexer capable of combining different wavelength signals into a common path, and wherein the wavelength division multiplexer is further coupled to an optical amplifier adapted to at least partially compensate for loss associated with the transmission star fabric.

11. The network of claim 8, wherein the optical switching fabric is further coupled to one or more tunable lasers.

12. The network of claim 8, wherein the optical switching fabric comprises one or more optical devices selected from a group consisting of micro-electromechanical switches (MEMS) and liquid crystal devices.

13. The network of claim 8, wherein traffic through the optical switching fabric comprises one or more express channels that bypass optical-to-electrical conversion at a location associated with the optical switching fabric.

14. The network of claim 8, wherein traffic transmitted through the optical switching fabric comprise at least in part Multi-Protocol Label Switching (MPLS) or Generalized Multi-Protocol Label Switching (GMPLS) packets.

15. A method of directing optical signals, the method comprising:

generating, at a scheduler engine, one or more control signals;

- converting at least a portion of the one or more control signals into an optical control signal;
- distributing the optical control signal using a transmission star fabric to a first plurality of line cards, each of the first plurality of line cards comprising one or more receivers coupled to an electronic processor and further coupled to one or more optical transmitters;
- receiving, at the one or more receivers, the optical control signal;
- communicating, from the one or more optical transmitters, one or more optical output signals to the transmission star fabric, wherein the one or more optical output signals are communicated based at least in part on a portion of information of the one or more control signals, and wherein the optical control signal is at a different optical wavelength than at least some of the one or more optical output signals;
- combining, in the transmission star, at least some of the optical output signal into one or more combined optical output signals; and
- receiving, at the scheduler engine, at least some information of the one or more combined output signals;
- communicating at least some of the information from the combined output signals from the scheduler engine to a second plurality of line cards through an optical switching fabric;
- producing a more uniform traffic distribution at one or more outputs from the optical switching fabric compared with one or more inputs to the optical switching fabric;
- wherein the one or more control signals generated by the scheduler engine control firing of the one or more transmitters using a scheduling algorithm that operates to avoid collisions between the optical output signals in the transmission star fabric.
- 16.** The method of claim 15, wherein the one or more optical output signals comprise variable length packets, each of the variable length packets comprising a header and a variable length payload.
- 17.** The method of claim 15, wherein the transmission star fabric is further coupled to an optical amplifier operable to at least partially compensate for loss associated with the transmission star fabric.
- 18.** The method of claim 15, wherein traffic through the optical switching fabric comprises one or more express channels that bypass optical-to-electrical conversion at a location associated with the optical switching fabric.
- 19.** The method of claim 15, wherein the optical switching fabric comprises one or more optical devices selected from a group consisting of micro-electromechanical switches (MEMS) and liquid crystal devices.
- 20.** The method of claim 15, wherein the transmission star fabric is further coupled to an Ethernet network.
- 21.** The method of claim 15, wherein traffic transmitted through the optical switching fabric comprise at least in part an Internet Protocol (IP) packet, a Transmission Control Protocol (TCP) packet, a Multi-Protocol Label Switching (MPLS) packet, or a Generalized Multi-Protocol Label Switching (GMPLS) packet.
- 22.** A network operable to direct optical signals, the network comprising:
- a scheduler engine operable to generate one or more control signals;
  - one or more control lasers coupled to the scheduler engine, each of the one or more control lasers operable to generate an optical control signal based at least in part on a portion of the one or more control signals, wherein the optical control signal comprises at least a portion of information of the one or more control signals;
  - a transmission star fabric coupled to the one or more control lasers, the transmission star fabric operable to distribute the optical control signal to a first plurality of line cards, each of the first plurality of line cards comprising one or more receivers coupled to an electronic processor and further coupled to one or more optical transmitters, the one or more receivers adapted to receive the optical control signal, the one or more optical transmitters adapted to communicate one or more optical output signals to the transmission star fabric, the one or more optical output signals communicated based at least in part on the portion of information of the one or more control signals, wherein the optical control signal is at different optical wavelengths than at least some of the one or more optical output signals;
- wherein the one or more optical output signals comprise variable length packets, each of the variable length packets comprising a header and a variable length payload;
- wherein the transmission star fabric is operable to combine at least some of the optical output signals into one or more combined optical output signals and to direct at least a portion of the one or more combined output signals to an input buffer;
- wherein the one or more control signals generated by the scheduler engine control firing of the one or more transmitters using a scheduling algorithm that operates to avoid collisions between the optical output signals in the transmission star fabric;
- wherein the scheduler engine is further coupled to an optical switching fabric, wherein the scheduler engine is operable to receive at least some of the information of the one or more combined output signals and to communicate at least some of the information of the one or more combined output signals to a second plurality of line cards through the optical switching fabric; and
- wherein the optical switching fabric comprises one or more optical devices selected from a group consisting of micro-electromechanical switches (MEMS) and liquid crystal devices.
- 23.** The network of claim 22, wherein traffic transmitted through the optical switching fabric comprise at least in part Multi-Protocol Label Switching (MPLS) or Generalized Multi-Protocol Label Switching (GMPLS) packets.
- 24.** The network of claim 23, wherein traffic through the optical switching fabric comprises one or more express

channels that bypass optical-to-electrical conversion at a location associated with the optical switching fabric.

**25.** The network of claim 24, wherein the optical switching fabric is further coupled to one or more tunable lasers.

**26.** The network of claim 24, wherein the input buffer is further coupled to a wavelength division multiplexer capable of combining different wavelength signals into a common path, and wherein the wavelength division multiplexer is

further coupled to an optical amplifier adapted to at least partially compensate for loss associated with the transmission star fabric.

**27.** The network of claim 24, wherein the transmission star fabric is further coupled to an Ethernet network.

\* \* \* \* \*