



US 20220379181A1

(19) **United States**

(12) **Patent Application Publication**  
**Rife**

(10) **Pub. No.: US 2022/0379181 A1**

(43) **Pub. Date: Dec. 1, 2022**

(54) **MID ARMLOCK PUTTER AND GOLF GRIP**

(52) **U.S. Cl.**

(71) Applicant: **Guerin D. Rife**, Carlsbad, CA (US)

CPC ..... *A63B 53/14* (2013.01); *A63B 53/021*  
(2020.08); *A63B 53/007* (2013.01)

(72) Inventor: **Guerin D. Rife**, Carlsbad, CA (US)

(57)

**ABSTRACT**

(21) Appl. No.: **17/736,480**

(22) Filed: **May 4, 2022**

A putter type golf club includes a putter head with a ball striking face, a shaft attached to said putter head, and an elongated grip attached to the shaft. The elongated grip includes a lower section, an upper section and a cap forming a butt section at the upper area of the grip, the lower section of the elongated grip including a shaft opening at a lower end thereof, the lower section of the elongated grip structured to accommodate the hands of a golfer, the upper section of the elongated grip having a leading edge located in a direction toward and closest to an intended target with the putter head in a normal position prior to executing a normal putting stroke.

**Related U.S. Application Data**

(60) Provisional application No. 63/193,985, filed on May 27, 2021.

**Publication Classification**

(51) **Int. Cl.**

*A63B 53/14* (2006.01)  
*A63B 53/02* (2006.01)  
*A63B 53/00* (2006.01)

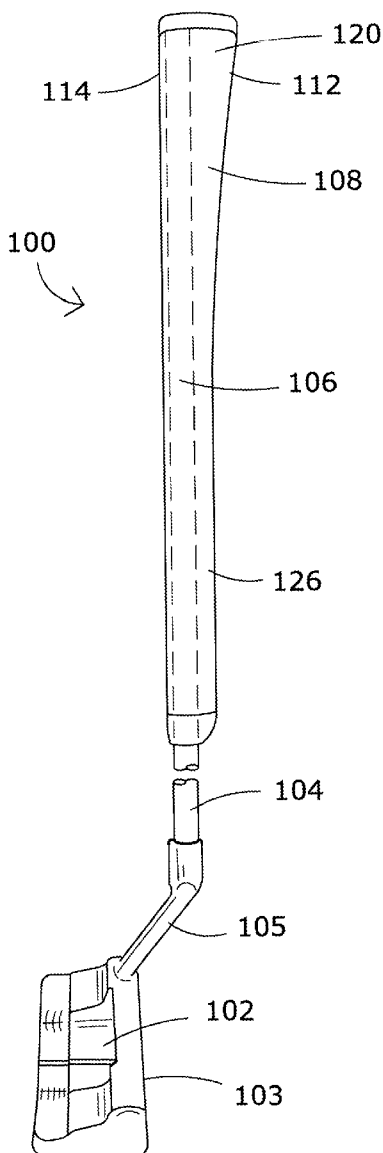

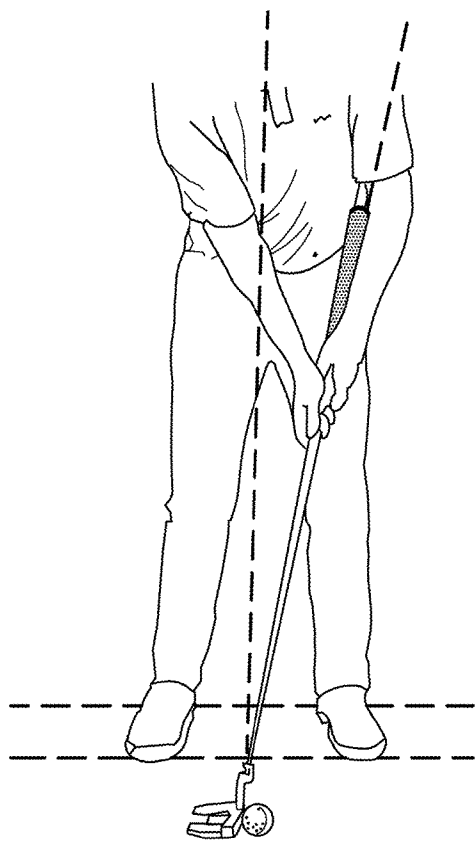

**FIG. 1**  
PRIOR ART

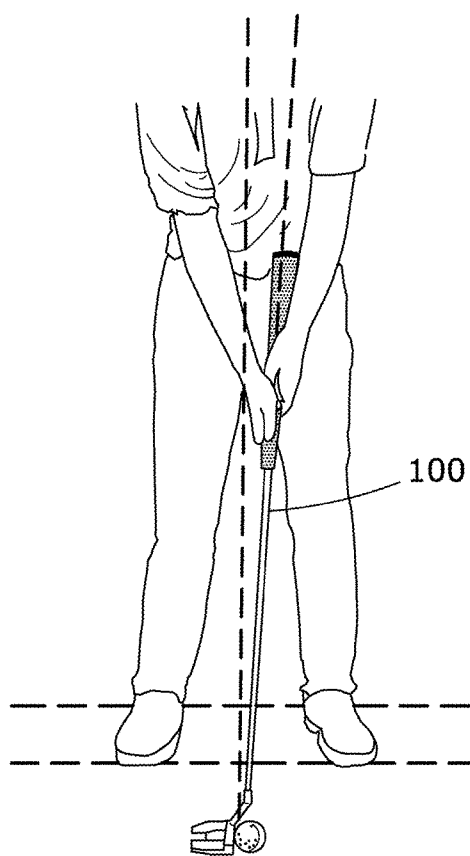

**FIG. 2**

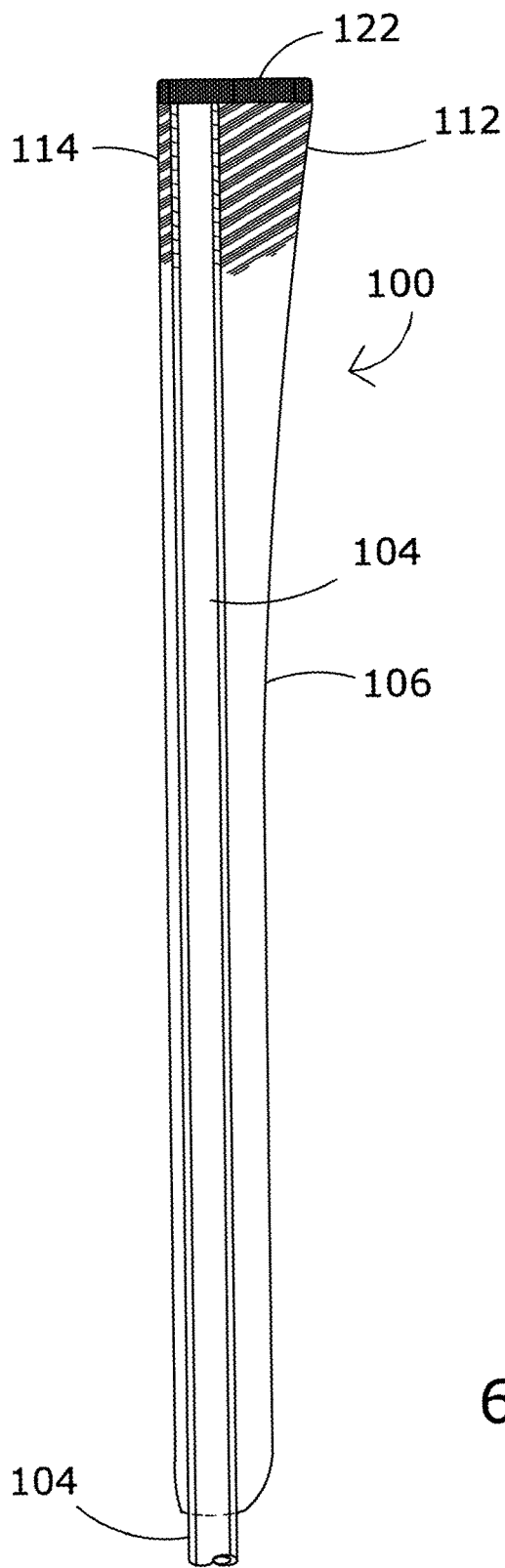

FIG. 6

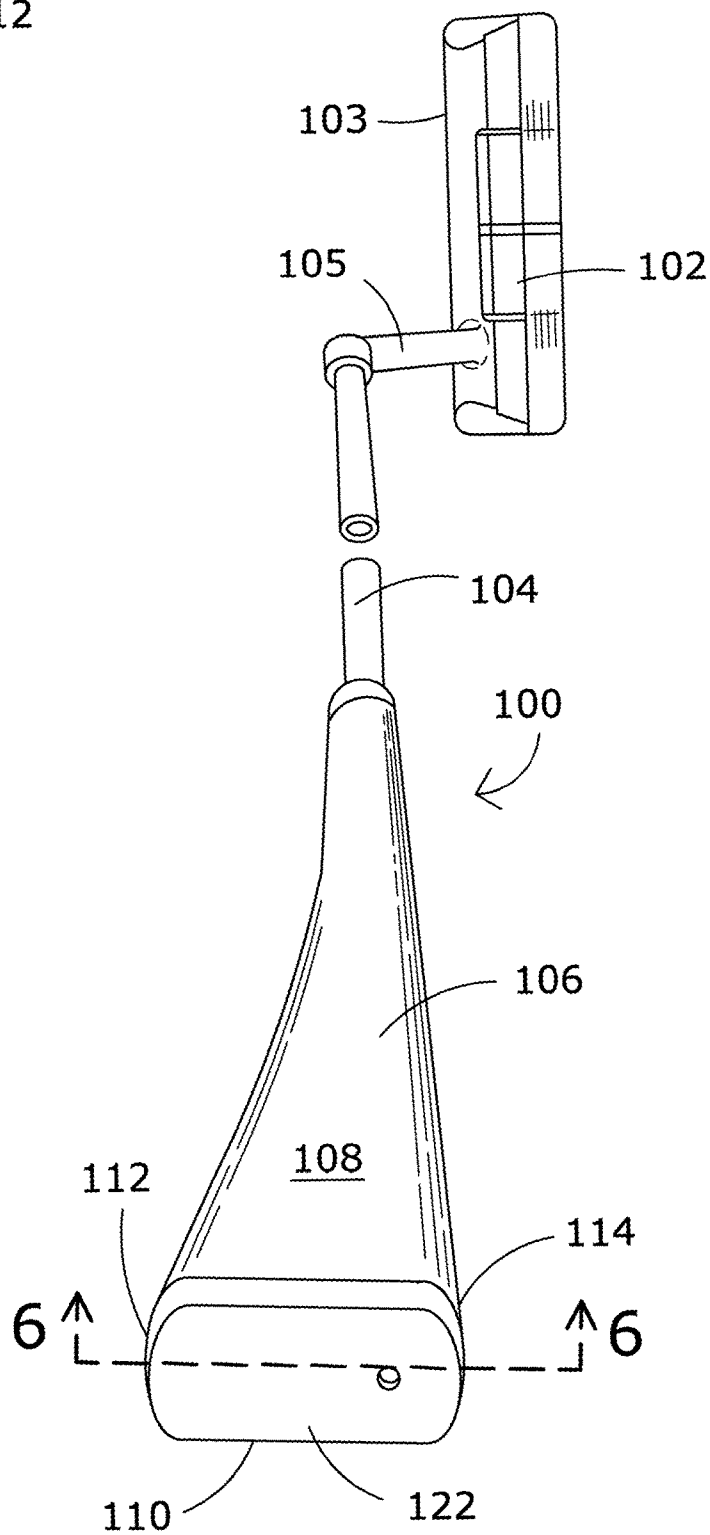

FIG. 4

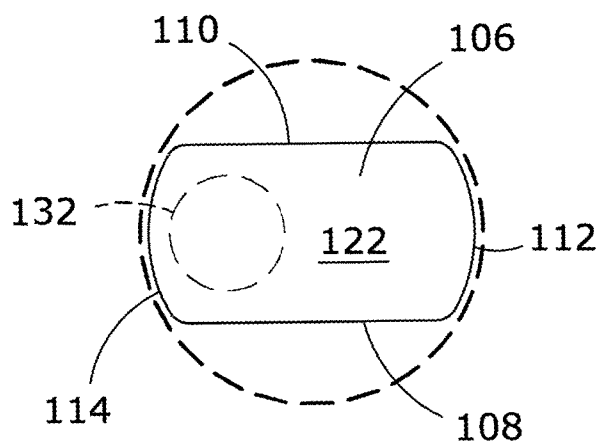

FIG. 5

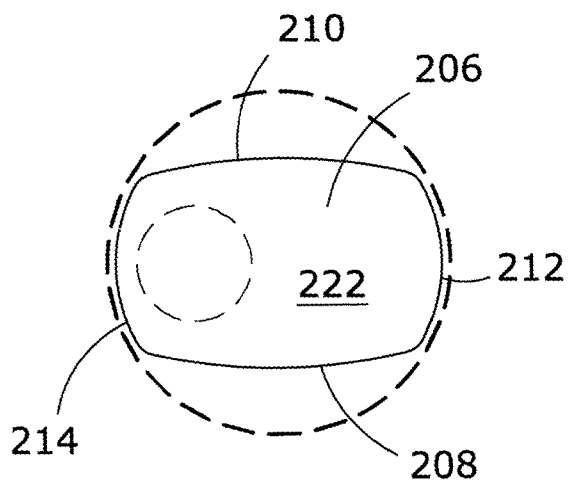

FIG. 7

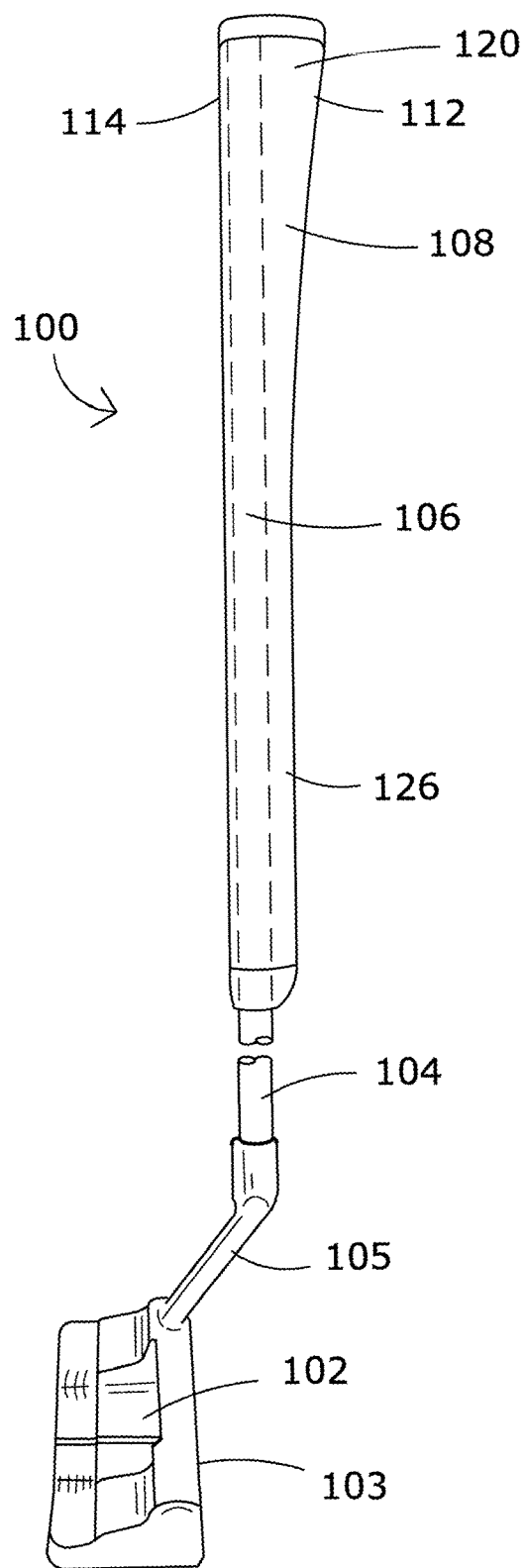

FIG. 3

**MID ARMLOCK PUTTER AND GOLF GRIP****SUMMARY OF THE DISCLOSURE****CROSS-REFERENCE TO RELATED APPLICATION**

**[0001]** This application claims the benefits of priority to U.S. Provisional Patent Application Ser. No. 63/193,985, filed May 27, 2021, the disclosure of which is incorporated by reference herein in its entirety.

**FIELD OF THE INVENTION**

**[0002]** The disclosure relates to golf putters and, in particular, to a golf putter that engages a golfer's leading arm to stabilize the position of the putter face during execution of a putting stroke.

**[0003]** It is well known that excessive movement of a golfer's hands and/or wrists while making a stroke with a putter typically results in inconsistencies in the angular position of the putter face, the putter path and the location on the putter face where a golf ball is struck. This results in variations of the distance and the direction that the golf ball rolls toward the intended target. Many attempts have been made to minimize or completely remove the excessive movement both on the structure of the putter and in the method the golfer uses in the putting stroke. For example, golfers may use a leading hand low grip on the putter or some variation of what is commonly known as a claw grip to stabilize the hand/wrist movement during the stroke.

**[0004]** In addition, various modifying attempts have been made to the structure of the putter within the guidelines of the USGA the ruling body of the golf world. There are golf putters with extended shafts that are used to engage a golfer's arm in order to stabilize the golfer's wrist and hands. An example is a putter with an extended shaft commonly known as an "armlock" putter.

**[0005]** A typical armlock putter is made with a heavy head that weighs approximately 400 to 440 grams, has a thick and rigid, "ski pole" shaft and a non-tapering, constant diameter grip that measures 17 to 20 inches in length. Because the grip on these putters is secured to a golfer's forearm, the shaft angle leans radically forward at an angle approaching 12 degrees requiring a putter face loft between 8 and 12 degrees in order to allow the golf ball, when struck, to roll smoothly rather than bounce. A further shortcoming of an armlock putter is that with the shaft leaning so far forward, the natural arc of the stroke path starts to rotate closed at the point of impact with the golf ball, thereby resulting in a pulled golf ball path that typically travels left of the target, which is a common fault in putting. Thus, conventional armlock putters create a challenge for the golfer to maintain the face angle square to the target line through the hitting area to avoid pulling the golf ball away from the intended target line.

**[0006]** Furthermore, because golfers are physically different and come in all shapes and sizes, standardization is essentially not possible. This results in a necessity of custom fitting each individual golfer, an expensive undertaking, given the individual components of the putter, the head, shaft and grip are not standard. Even with custom fitting, the problem of excessive shaft lean remains, requiring unwanted manipulation by the golfer during the execution of a putting stroke.

**[0007]** According to one aspect of the disclosure, a putter type golf club includes a putter head with a ball striking face. The putter type golf club also includes a shaft attached to said putter head. The putter type golf club further includes an elongated grip attached to the shaft, wherein the elongated grip includes a lower section, an upper section and a cap forming a butt section at the upper area of the grip, the lower section of the elongated grip including a shaft opening at a lower end thereof, the lower section of the elongated grip structured to accommodate the hands of a golfer, the upper section of the elongated grip having a leading edge located in a direction toward and closest to an intended target with the putter head in a normal position prior to executing a normal putting stroke, the upper section of the elongated grip having a maximum widest dimension of 1.75 inches, the maximum widest dimension of the elongated grip being further defined by being oriented in a direction perpendicular to said striking face. The shaft is attached to the elongated grip at a location where the center of the shaft is spaced from the leading edge of the upper section of the elongated grip by at least 1.25 inches.

**[0008]** According to another aspect of the disclosure, a putter type golf club includes a putter head with a ball striking face. The putter type golf club also includes a shaft. The putter type golf club further includes a grip wherein the grip includes a lower section and an upper section, the lower section being generally symmetrical for engagement of a golfer's hands, the upper section formed in a gradually wider, tapering parabolic configuration having a widest dimension at an uppermost area of the upper section and a narrowest width at a lower end of the upper section, wherein the widest dimension includes a width of approximately 1.75 inches, wherein the grip is further defined such that the widest dimension of the grip is oriented in a direction approximately perpendicular to the ball striking face and parallel to a normal target line when executing a putting stroke, and a center of the shaft is located 1.25 inches from a forward edge of the grip at the widest dimension.

**[0009]** According to yet another aspect of the disclosure, a putter type golf club includes a putter head with a ball striking face. The putter type golf club also includes a shaft coupled to the putter head. The putter type golf club further includes a grip coupled to the shaft, wherein the elongated golf grip includes a lower section, an upper section and a cap forming a butt section at the upper area of the grip, wherein the lower section includes a shaft opening at a lower end thereof, the lower section of the grip structured to accommodate the hands of a golfer. The upper section includes sides, a leading edge and a trailing edge, the leading edge of the grip located in a direction toward and closest to an intended target with the putter in a normal position prior to executing a normal putting stroke, the upper section of the elongated golf grip formed in a pistol configuration having a gradually decreasing width of the leading edge from the butt section downwardly to the lower section of the grip, wherein the upper section of the grip has a maximum widest dimension of 1.75 inches, the maximum widest dimension of the grip being further defined by being oriented in a direction perpendicular to the striking face. The shaft being offset toward said trailing edge of the grip at a location where the center of the shaft is spaced from the leading edge of the upper section of the grip at least 1.25 inches; the leading edge and the trailing edge of the upper section

having a radius of curvature not exceeding 0.875 inches. The ball striking face is offset rearwardly from the shaft by a dimension approximately equal to three shaft diameters.

[0010] Other aspects of the disclosure are apparent with reference to the following description and accompanying drawings.

#### DESCRIPTION OF THE DRAWINGS

[0011] FIG. 1 illustrates a golfer using a prior art armlock putter showing the relative position of the putter just prior to the putting stroke.

[0012] FIG. 2 illustrates a golfer using the putter disclosed herein.

[0013] FIG. 3 is an elevational view of the golf putter disclosed herein.

[0014] FIG. 4 is a top view of the putter of FIG. 3 as it is seen by a golfer in a position just prior to the putting stroke.

[0015] FIG. 5 is a close-up view of the upper butt surface of a golf grip used on the golf putter of FIG. 3.

[0016] FIG. 6 is a partial sectional view taken along the line 6-6 of FIG. 4.

[0017] FIG. 7 is a close-up view of the upper butt surface of another embodiment of the golf grip disclosed herein.

#### DETAILED DESCRIPTION

[0018] Referring to FIG. 1 shows a typical prior art, armlock putter held by a golfer in a setup position just prior to making a conventional putting stroke. In order to allow the upper portion of the golf grip to engage the forward—or leading—arm of the golfer, the putter must assume a substantial forward lean, as shown. In this position, the rear location of the putter head is as much as three to four times greater from vertical than the distance between the grip and a golfer's arm because of the length between the golfer's hands and the putter head as compared to the length between the hands and the top of the putter. This putter position requires a face angle of the putter head to be as much as 10 to 12 degrees of loft in order for the striking face to be presented to the golf ball at a relatively vertical impact position. Furthermore, the position of the leading arm due to the severe forward lean angle of the putter tends to cause a right handed golfer to close the putter face at ball impact causing a putt pulled in a left direction that travels in a divergent path away from the intended target line. Typically a golfer must make some sort of adjustment to the putting stroke to overcome this shortcoming of conventional armlock putters.

[0019] FIG. 2 shows a golfer using a putter 100 in accordance with the present disclosure, where it is apparent that the forward shaft lean assumes a much less severe angle of at least four degrees, such that the putter is held in a more conventional upright position enabling the golfer to better execute a conventional putting stroke.

[0020] FIGS. 3-6 show the golf putter 100 disclosed herein and includes a putter head 102, a shaft 104 and a grip 106. The putter head 102 may be any conventional design, such as a mallet or blade type, having a ball striking face 103. As seen in particular in the front elevational view of FIG. 3, when the putter 100 is used in a normal manner to execute a putting stroke, the putter head 102 and the ball striking face 103 are offset rearwardly from the shaft 104 with an integral hosel 105 connected between the putter head 102 and the shaft 104. The rearward offset of the putter

head 102 created by the hosel 105 locates the putter head 102 behind the shaft 104 at a width of approximately three shaft diameters in a more normal position toward the middle of the golfer's stance when the grip 106 leans forward against a golfer's arm. The offset allows a slightly lesser loft angle of the putter face 103 since the putter head 102 lags behind the shaft 104 such that when the putter head 102 actually reaches the golf ball it is moving in an ever so slight upward and arcuate motion. A face loft angle is no greater than 6 degrees in some embodiments, as compared to significantly greater face loft angles used with conventional armlock putters.

[0021] The structure of the putter 100 is completed with an elongated golf grip 106 formed of an upper, wider section 120 that is able to engage the mid-forearm of the golfer and a lower section 126 that serves as a gripping area for the golfer's hands. In some embodiments, the grip 106 is at least approximately 14 to 17 inches in length, which is approximately 5 to 6 inches longer than typical conventional putter grips.

[0022] The upper section 120 of the golf grip 106 has a generally flat surface 108 that faces the golf ball when the putter 100 is aligned in preparation for making a putting stroke. The upper surface 120 of the grip 106 also includes a generally flat rear surface 110, a rounded, leading side edge 112 that faces the target and a rounded, trailing side edge 114. In the disclosed embodiments, the upper section 120 is formed as a pistol configuration, or shape, such that the leading side edge 112 that faces the target is widest at the uppermost part and gradually tapers downwardly and inwardly in a parabolic curve, as seen in FIGS. 3 and 4. A top or butt surface 122 forms a closure of the grip 106 and is the widest part of the grip 106 having a width of approximately, but no greater than, 1.75 inches. The grip 106 has a lower section 126 from approximately midway of the length of the grip 106 of approximately 1.00 inch in diameter downwardly and maintains that width throughout the lowermost, bottom section 126 of the grip 106 to provide a symmetrical gripping surface for the golfer's hands. The lower section 126 may be round or have flattened sides that fit the hands.

[0023] As shown in greater detail in FIG. 5, the upper or butt surface 122 of the golf grip 106 has a generally flattened, elongated oval shape with a rounded leading end 112, a rounded trailing end 114 and flat sides 108 and 110 with the aforementioned width being no greater than 1.75 inches in any direction. The rounded ends 112 and 114 both have a radius of not greater than 0.875 inches that enables the maximum width to be 1.75 inches measured in any given direction across the butt surface 122 as compared with a grip having a square end where the maximum width is only available at a diagonal measurement.

[0024] The grip 106 includes a shaft bore 132, as seen in phantom in FIG. 5, that is spaced adjacent and close to the entire trailing side edge 114 of the grip 106 whereby the shaft 104 is offset toward the rear trailing side edge 114 of the grip 106 and positioned at or nearly perpendicular to the target line when the putter 100 is set up and aligned just prior to the execution of a putting stroke. The center of the shaft 104 is spaced 1.25 inches from the leading edge 112 of the grip 106 in some embodiments.

[0025] With the golf grip 106 properly installed on the putter shaft 104, the maximum width of the butt surface 122 of the grip 106 is aimed toward the target and is perpen-

dicular to striking face **103** of the putter **100**, thereby allowing the face **103** of the putter **100** to face the target. Thus, when the golfer secures the pistol shaped, upper section **120** of the grip **106** against the golfer's leading arm to prevent excessive rotation of the putter face **103** during a putting stroke, proper alignment of the putter **100** to the target is maintained.

**[0026]** FIG. 7 shows an alternate embodiment of a golf grip **206** of the present invention, wherein the overall shape may be made more oval as long as the maximum width of 1.75 inches is maintained. In this embodiment, as seen the upper butt surface **222** has a side edge **212** toward the ball and a rear edge **214** toward the golfer. The side **208** facing the golf ball and the side **210** facing the golfer both are arcuate in shape without altering the position of the shaft which is spaced approximately 1.25 inches from the front edge.

**[0027]** The embodiments disclosed herein relates to a putter which provides all features of conventional armlock putter, while using a common weighted putter head and shaft. The armlock putter disclosed herein utilizes a unique grip design having a pistol configuration with a maximum allowed width dimension, thus conforming with USGA rules for implements. The grip is designed to engage the golfer's leading arm such that it locates the shaft away from the forearm a maximum distance to reduce shaft lean by as much as 5 degrees to allow a golfer to simply forward press and execute the putting stroke while maintaining the putter angle in a normal, more upright position. The wide upper portion of the grip engaging the golfer's leading forearm also promotes the elimination of wrist movement resulting in a one-piece shoulder swing of the putter during a putting stroke thereby eliminating moving parts that cause poor putting performance.

**[0028]** In some embodiments, the putter disclosed herein includes a standard head and shaft while using a golf grip that is specifically designed for an armlock putting technique. According to some embodiments, the grip has a length of at least 14 to 17 inches. The lower section of the grip is designed to be gripped by the hands when executing a normal putting stroke. The upper section of the grip is located above the golfer's hands approximately 6 inches in a position where it is able to engage the forearm of the golfer during a putting stroke. In some embodiments, the upper section has a shape commonly known in the art as a pistol shape or pistol grip. In keeping with USGA rules for implements, the maximum width of the upper pistol section of the grip is 1.75 inches. In order to maximize the effectiveness of the grip of the present invention, the golf shaft is located at the extreme rear side of the grip away from the target when the putter is used in a normal putting stroke. With the grip in the desired location on the putter, the shaft is offset toward the rear, straight edge of the grip and the center of the shaft is located 1.25 inches from the furthest front edge of the pistol section in some embodiments. This grip structure decreases the shaft lean of the putter by 5 degrees when the forward edge of the grip engages the forearm of the golfer.

**[0029]** When a pistol grip is typically installed on a shaft of a conventional putter, the pistol section faces rearwardly, that is toward the golfer and perpendicular to the target line when the putter is in a normal position in order to strike a ball toward the hole. In the present disclosure, the pistol section of the grip is located in a forward position toward the

golfer's leading arm nearest to the hole and is pointed toward and parallel to the intended target line. Because the shaft is on the straight side of the grip, opposite the pistol section, it follows that when the grip engages the golfer's leading arm, the shaft is further located from the golfer's leading arm at a maximum distance permitted under the rules of golf than it would be if the pistol section was in the traditional rearward direction of the grip. This, in turn, results in less forward lean of the entire shaft, allowing the putter to assume a greater perpendicular location relative to the ground such that the golfer is able to make a more natural putting stroke even though the grip is held against the golfer's leading arm.

**[0030]** The upper, pistol shaped section of the grip has a generally flat side facing the golf ball and a complimentary flat side facing toward the golfer when the putter is in a normal address or ball-striking position whereby the greatest width of the grip is essentially parallel to a target line used by the golfer. The ends of the upper section of the grip have front and rear rounded or arcuate sides, preferably with a radius of 0.875 inches in order not to exceed the maximum butt diameter dimension of 1.750 inches allowed by the USGA rules. The grip structure allows the golfer to position the forwardly facing pistol section of the grip against the golfer's mid forearm to lock the putter against excessive movement during the putting stroke. The lower portion of the grip below the pistol shaped upper section of the grip is a conventional symmetrical design and is the area where a golfer's hands typically will engage the grip. The grip structure permits engagement with the leading arm while reducing shaft lean found in conventional armlock putters. This, in turn, allows the putter to use conventional components including a lighter weight putter head with a normal loft configuration.

**[0031]** Another feature of the putter of the disclosed embodiments is a rearward offset of the putter head that puts the putter head behind the shaft, utilizing an angular hosel between the end of the shaft and the putter head, creating a more normal position toward the middle of the golfer's stance when the shaft leans forward against a golfer's arm. In some embodiments, the face is rearwardly offset approximately three shaft diameters and this may be accomplished using a variety of hosel shapes.

**[0032]** Typically when a shaft of a putter leans forward toward the target the face angle decreases. It follows an increase in the loft angle of the putter face would be needed to prevent the golf ball from being driven into the surface of the putting green causing an inconsistent role of the golf ball and subsequent poor putting results. The rearward offset of the putter face of the present invention permits a slightly lesser loft angle of the putter face since the putter head lags behind the shaft such that when the putter head actually reaches the golf ball it is moving in an ever so slightly upward, more lofted motion.

**[0033]** The embodiments disclosed herein provide a golf putter that is conducive to establishing a standardized method of manufacturing an armlock type putter that can be marketed to the general golfing public which does not require customization.

**[0034]** It will be appreciated that still other modifications to the grip and putter structure described above may be made in keeping within the spirit and scope of the following claims.

What is claimed is:

- 1. A putter type golf club comprising:
  - a putter head with a ball striking face;
  - a shaft attached to said putter head; and
  - an elongated grip attached to the shaft, wherein the elongated grip includes a lower section, an upper section and a cap forming a butt section at the upper area of the grip, the lower section of the elongated grip including a shaft opening at a lower end thereof, the lower section of the elongated grip structured to accommodate the hands of a golfer, the upper section of the elongated grip having a leading edge located in a direction toward and closest to an intended target with the putter head in a normal position prior to executing a normal putting stroke, the upper section of the elongated grip having a maximum widest dimension of 1.75 inches, the maximum widest dimension of the elongated grip being further defined by being oriented in a direction perpendicular to said striking face;
  - the shaft being attached to the elongated grip at a location where the center of the shaft is spaced from the leading edge of the upper section of the elongated grip by at least 1.25 inches.
- 2. The putter type golf club of claim 1, wherein the upper section of the elongated grip is formed in a pistol configuration having a gradually decreasing width of the leading edge from the butt section downwardly to the lower section of the elongated grip.
- 3. The putter type golf club of claim 1, wherein the shaft is on a straight side of the elongated grip.
- 4. The putter type golf club of claim 1, wherein the ball striking face is offset rearwardly from the shaft by a dimension approximately equal to three shaft diameters.
- 5. The putter type golf club of claim 4, further comprising an angular hosel between the putter head and a lower end of the shaft.
- 6. The putter type golf club of claim 1, wherein the butt section is structured in a flattened, elongated oval configuration oriented in a direction perpendicular to the ball striking face.
- 7. A putter type golf club comprising:
  - a putter head with a ball striking face;
  - a shaft; and
  - a grip wherein the grip includes a lower section and an upper section, the lower section being generally symmetrical for engagement of a golfer's hands, the upper section formed in a gradually wider, tapering parabolic configuration having a widest dimension at an uppermost area of the upper section and a narrowest width at a lower end of the upper section, wherein the widest

dimension includes a width of approximately 1.75 inches, wherein the grip is further defined such that the widest dimension of the grip is oriented in a direction approximately perpendicular to the ball striking face and parallel to a normal target line when executing a putting stroke, and a center of the shaft is located 1.25 inches from a forward edge of the grip at the widest dimension.

- 8. The putter type golf club of claim 7, wherein the grip includes flat sides and arcuate ends with a radius of curvature of 0.875 inches.
- 9. A putter type golf club comprising:
  - a putter head with a ball striking face;
  - a shaft coupled to the putter head; and
  - a grip coupled to the shaft, wherein the elongated golf grip includes a lower section, an upper section and a cap forming a butt section at the upper area of the grip, wherein the lower section includes a shaft opening at a lower end thereof, the lower section of the grip structured to accommodate the hands of a golfer;
- wherein the upper section includes sides, a leading edge and a trailing edge, the leading edge of the grip located in a direction toward and closest to an intended target with the putter in a normal position prior to executing a normal putting stroke, the upper section of the elongated golf grip formed in a pistol configuration having a gradually decreasing width of the leading edge from the butt section downwardly to the lower section of the grip, wherein the upper section of the grip has a maximum widest dimension of 1.75 inches, the maximum widest dimension of the grip being further defined by being oriented in a direction perpendicular to the striking face;
- the shaft being offset toward said trailing edge of the grip at a location where the center of the shaft is spaced from the leading edge of the upper section of the grip at least 1.25 inches; the leading edge and the trailing edge of the upper section having a radius of curvature not exceeding 0.875 inches; and
- wherein the ball striking face is offset rearwardly from the shaft by a dimension approximately equal to three shaft diameters.
- 10. The putter type golf club of claim 9, further comprising an angular hosel between the putter head and a lower end of the shaft.
- 11. The putter type golf club of claim 9, wherein the butt section is structured in a flattened, elongated oval configuration with a widest dimension oriented in a direction perpendicular to the putter face.

\* \* \* \* \*