

(No Model.)

J. H. DIXON.  
SPRINKLER HEAD.

No. 525,946.

Patented Sept. 11, 1894.

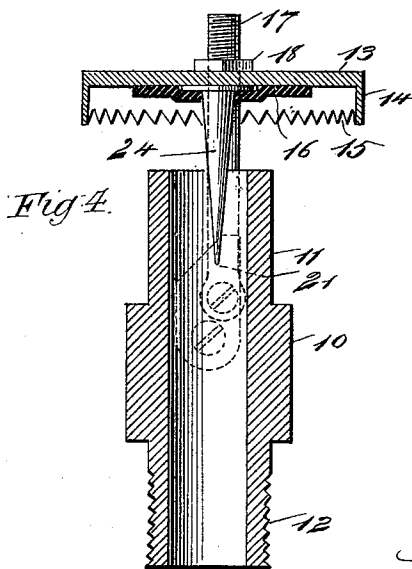
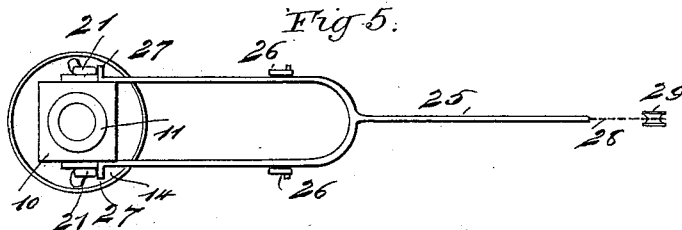
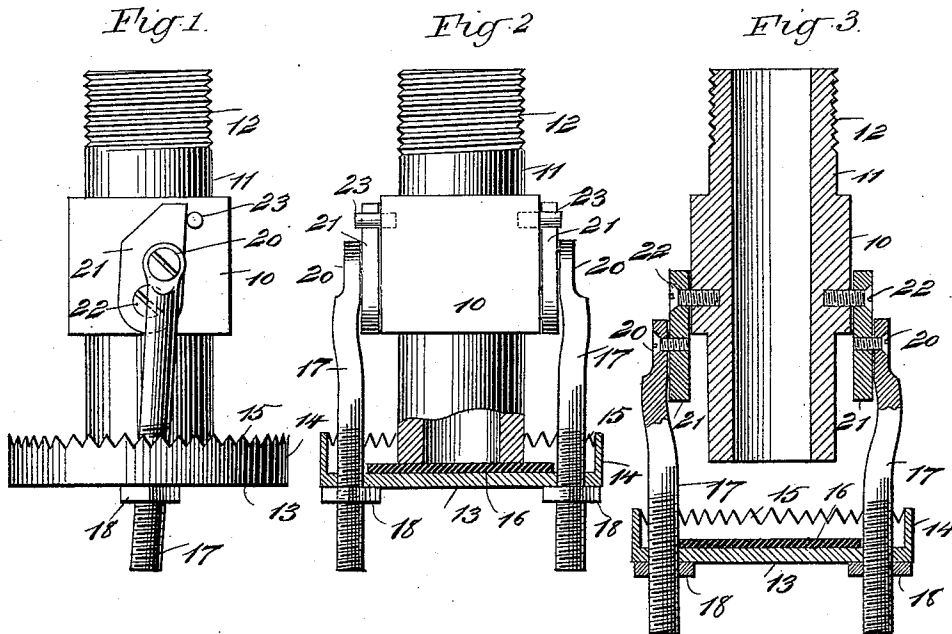

WITNESSES:

*Paul Jakob*  
*H. P. Hutchinson*

INVENTOR

*J. H. Dixon*  
BY *Munn & Co.*

ATTORNEYS.

# UNITED STATES PATENT OFFICE.

JOHN H. DIXON, OF MARIETTA, OHIO.

## SPRINKLER-HEAD.

SPECIFICATION forming part of Letters Patent No. 525,946, dated September 11, 1894.

Application filed March 20, 1894. Serial No. 504,392. (No model.)

*To all whom it may concern:*

Be it known that I, JOHN H. DIXON, of Marietta, in the county of Washington and State of Ohio, have invented a new and Improved Sprinkler-Head, of which the following is a full, clear, and exact description.

My invention relates to improvements in that class of sprinkler heads which are used in connection with automatic fire extinguisher systems and which are operated when the heat rises above a certain temperature, so as to open a valve and permit water to flow through and sprinkle over adjacent points so as to extinguish the fire.

The object of my invention is to produce a very simple sprinkler head of this class which has fusible parts, but which has these parts arranged in such a way that they do not either directly or indirectly affect the sealing of the sprinkler head, which has an automatic valve arranged to normally close the sprinkler head, which has the valve supported in such a way that the water pressure in it forces it open when the fusible stops hereinafter described are softened, and which has the valve constructed so that it forms an excellent deflector and throws the water evenly around all sides of the sprinkler head.

To these ends my invention consists of certain features of construction and combinations of parts, which will be hereinafter described and claimed.

Reference is to be had to the accompanying drawings, forming a part of this specification, in which similar figures of reference indicate corresponding parts in all the views.

Figure 1 is a side elevation of the sprinkler head embodying my invention, with the valve closed. Fig. 2 is a front elevation, partly in section, of the same. Fig. 3 is a central longitudinal section with the valve open. Fig. 4 is a slightly modified form of the sprinkler head, with the valve open and arranged above the head; and Fig. 5 is a plan view of a modified form of the sprinkler head and of the valve releasing mechanism.

The sprinkler head has a rectangular body portion 10, although it may be of other shapes, if desired, which is formed on a pipe 11 this being flat ended and having one end screw-threaded, as shown at 12, to enable it to be conveniently coupled to a water supply pipe.

The other end of the pipe is adapted to be closed by a flat valve 13 which also serves as a deflector when it is open and which has an upturned side flange 14 provided with a serrated edge 15 through the serrations of which the water issues in numerous jets when the valve is open, as hereinafter described. The valve is provided, on its upper side, with a packing 16 to enable it to fit water tight against the pipe. The valve 13 is supported on the threaded rods 17 which together serve as a hanger, and which project downward through the valve, being held thereto by nuts 18, which are arranged beneath the valve and by which the valve may be adjusted so as to cause it to bear with the requisite tension on the open end of the pipe 11. The upper ends of the rods 17 are pivoted, as shown at 20, to the swinging arms 21 which are pivoted to the body 10 on opposite sides, as shown at 22, and the free ends of which are adapted to rest against the fusible stops 23 on the body 10. The pivots 22 and 20 and the stops 23 are arranged so that the pivots 20 are off the center, and hence if the stops 23 soften under the influence of heat, the water pressure on the valve causes it to pull down on the rods 17 and these, acting on the arms 21, cause them to cut off the stop 23 and this lets the arms swing down into the position shown in Fig. 3, with the valve 13 held immediately below the pipe 11, and the water which issues from the pipe strikes on the valve and is deflected on all sides through the serrations 15, thus thoroughly sprinkling all surrounding objects.

It will be seen that the device is of great simplicity and that, in case the temperature rises so as to soften the stops 23, it is sure to operate. In some cases it may be desirable to have the valve 13 above the pipe 11, in which case the sprinkler head is simply turned bottom side up, as shown in Fig. 4, and when it is intended to use the sprinkler head in this way it is desirable to have a guide pin 24 on the valve, which pin projects into the pipe 11, and when the valve is raised by the water pressure, the pin 24 prevents the valve from swinging to one side and thus causes it to perfectly serve its function as a deflector.

In Fig. 5 I have shown a modified form of the device which may be used as an automatic sprinkler head or a manually operated one,

and in this case I use a tilting lever 25 which is forked and is fulcrumed, near the center, as shown at 26, the ends of its members terminating in fusible stops 27 against which the arms 21 abut, and it will be seen that in case the stops are fused, the arms swing down in the manner already described and permit the outflow of water. The lever 25 has a non-fusible cord 28 at its free end, which runs over a suitable guide pulley 29 and may be carried to any desired quarter, and if it is desired to release the valve and open the sprinkler head, it may be done by pulling on the cord so as to tilt the lever 25 and throw the stops 27 out of the way of the arms 21.

Having thus described my invention, I claim as new and desire to secure by Letters Patent—

1. A sprinkler head, comprising a pipe, a valve hung thereon and adapted to close one end of the pipe, an extensible hanger to hold the valve to the pipe, and fusible stops in the

path of one member or section of the hanger and against which said part rests to prevent the elongation of the hanger, substantially as described.

2. A sprinkler head, comprising a pipe, a pair of arms pivoted thereon, fusible stops extending into the paths of the arms, and a valve suspended from the arms and adapted to normally close the pipe, substantially as described.

3. A sprinkler head, comprising a pipe, a pair of arms pivoted on opposite sides thereof, fusible stops extending into the paths of the arms, hanger rods pivoted on the arms, and a flat valve carried by the hanger rods and adapted to close against the end of the pipe, substantially as described.

JOHN H. DIXON.

Witnesses:

D. S. MILNE,  
LOUIS SHILLING.