

[54] **DIRECTIONAL GUIDE FOR POWER HAND DRILL**

3,664,032 5/1972 Tompkins ..... 33/334

[76] **Inventor:** Lloyd J. Wolf, Rt. 1, Box 45,  
 Roanoke, Tex. 76262

*Primary Examiner*—Samuel B. Rothberg  
*Assistant Examiner*—Steven L. Stephan  
*Attorney, Agent, or Firm*—F. Travers Burgess

[22] **Filed:** June 14, 1973

[21] **Appl. No.:** 369,924

[52] **U.S. Cl.**..... 33/334, 33/371, 33/384,  
 33/390

[51] **Int. Cl.**..... G01c 9/28, G01c 9/36

[58] **Field of Search** ..... 33/334, 347, 372, 370,  
 33/376, 371, 373, 390, 384

[57] **ABSTRACT**

A power hand drill is provided with a device for assisting its operator in accurately positioning its bit horizontally for drilling vertical surfaces and vertically for drilling horizontal surfaces. The positioning-assisting device comprises a circular bubble type level mounted for selective securement to surfaces of the drill housing parallel and normal respectively to the drill axis.

[56] **References Cited**  
**UNITED STATES PATENTS**

2,877,561 3/1959 Morse ..... 33/368

**3 Claims, 4 Drawing Figures**

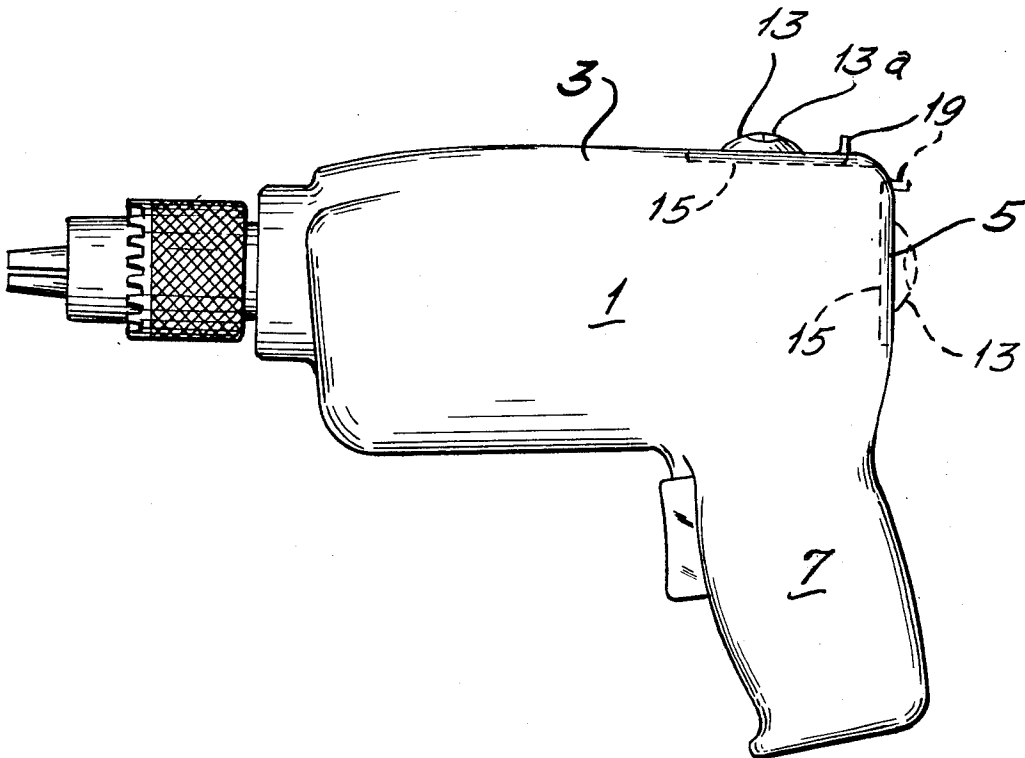

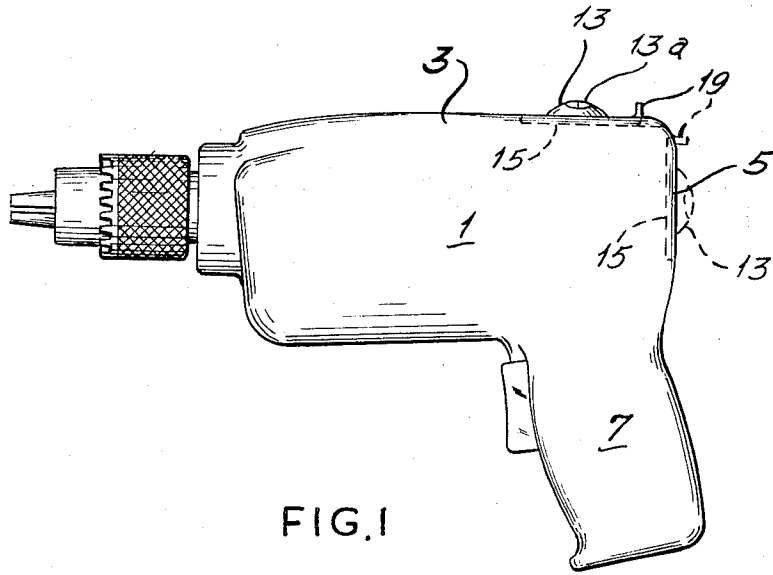

FIG. 1

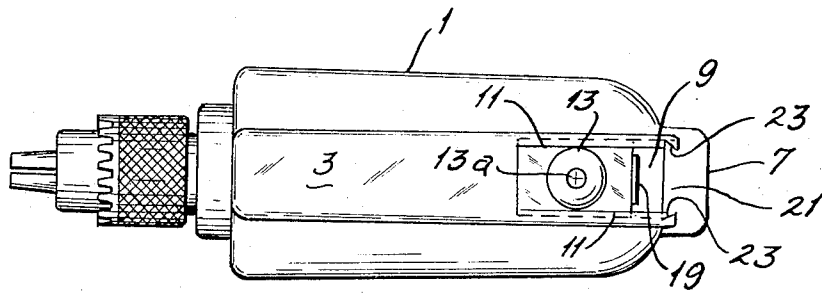

FIG. 2

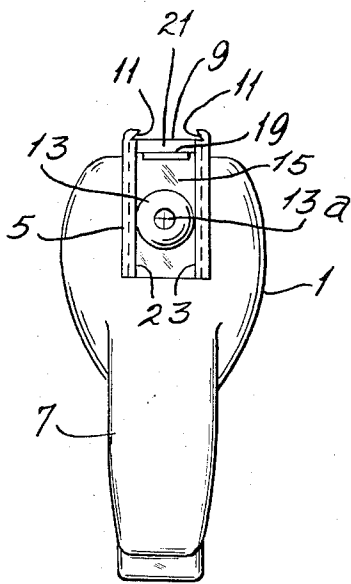

FIG. 3

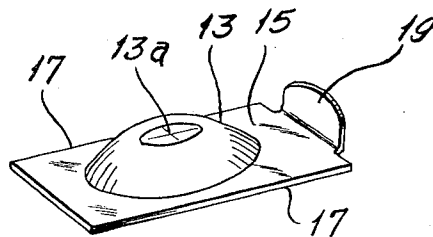

FIG. 4

**DIRECTIONAL GUIDE FOR POWER HAND DRILL**

**BACKGROUND OF THE INVENTION**

**1. Field of the Invention**

The invention relates to power drills and consists particularly in means for selectively facilitating accurate guidance of the drill in horizontal and vertical directions.

**2. The Prior Art**

U.S. Pat. No. 2,525,387 to Volk and U.S. Pat. No. 2,877,561 to Morse both disclose inclinometers mounted on electric drills to aid the user in aiming them at any desired angularity. Both of the patented devices utilize relatively complex inclinometer devices, require accurate visual maintenance of the inclinometer at the desired angular setting throughout the drilling operation to assure the desired angularity of the hole.

**SUMMARY OF THE INVENTION**

The invention provides a simple, inexpensive, compact and easily operated means for accurately guiding a power drill in horizontal or vertical directions.

**BRIEF DESCRIPTION OF THE DRAWING**

FIG. 1 is a side elevational view of an electric hand drill incorporating the invention.

FIG. 2 is a top view of the drill illustrated in FIG. 1.

FIG. 3 is a rear end elevational view of the drill illustrated in FIGS. 1 and 2.

FIG. 4 is a perspective view of the drill guidance assisting device.

**DETAILED DESCRIPTION OF THE INVENTION**

An electric hand drill has a housing 1 formed with a top surface 3 parallel to the drill axis and a rear end surface 5, above handle 7, normal to the drill axis.

For assistance in guiding drill 1, 7 horizontally, a shallow elongated slot 9 with its longitudinal sides undercut as at all to form a dovetail cross section is formed in the rear portion of drill housing top surface 3, with its rear end open.

A spirit level 13 of the circular bubble type is mounted on a plate 15 having its longitudinal sides 17, 17 spaced and shaped for sliding engagement with undercut sides 11, 11 of slot 9 so that level 13 may be removably secured to the drill housing top surface 3 by sliding plate 15 into slot 9. To facilitate insertion and

removal of plate 15, it is formed on one end with an upwardly extending tab 19 for engagement by the drill user's fingers.

5 With level 13 secured to the top of the drill housing as shown in FIGS. 1 and 2, the user of the drill may guide the drill horizontally, for drilling into a vertical surface, simply by keeping bubble 13a centered in the level 13 as he drills.

10 For drilling vertical holes, as in horizontal surfaces such as floors, the rear surface 5 of drill housing 1 is formed with a vertical slot 21, similar to slot 9, with an open upper end and undercut sides 23, 23 spaced apart to slidably receive the sides of plate 15 when the latter is inserted from the upper end of the slot.

15 With level 13 secured to the rear end of the drill housing as shown in FIG. 3, the user of the drill may guide the drill vertically for drilling into a horizontal surface, simply by keeping bubble 13a centered in level 13 as he drills.

20 When the level 13 is not in use, it may be removed from the drill and stored in the user's tool box.

The details of the invention may be varied substantially without departing from the spirit of the invention and the exclusive use of such modifications as come within the scope of the appended claims is contemplated.

**I claim:**

1. The combination including a power hand drill having a housing with its top wall generally parallel to the drill axis and its rear end wall generally normal to the drill axis, a spirit level of the circular bubble type, and means for selectively securing said level to said drill parallel to and normal to the drill axis said selective securing means comprising a plate mounting said spirit level to form a low-profile assembly and a pair of slots along each of the top and rear end walls of said housing parallel to and normal to the drill axis respectively for alternately slidably receiving opposite edges of said plate.

2. The combination according to claim 1 wherein said slots are formed with undercut sides matingly engageable with the side edges of said plate.

3. The combination according to claim 2 wherein said plate is formed with an upstanding finger-grip tab on one of its ends.

\* \* \* \* \*

50

55

60

65