

A. C. RICKSECKER, JR.  
 VALVE.  
 APPLICATION FILED MAY 6, 1905.

908,138.

Patented Dec. 29, 1908.

*my*  
 Fig. 1.

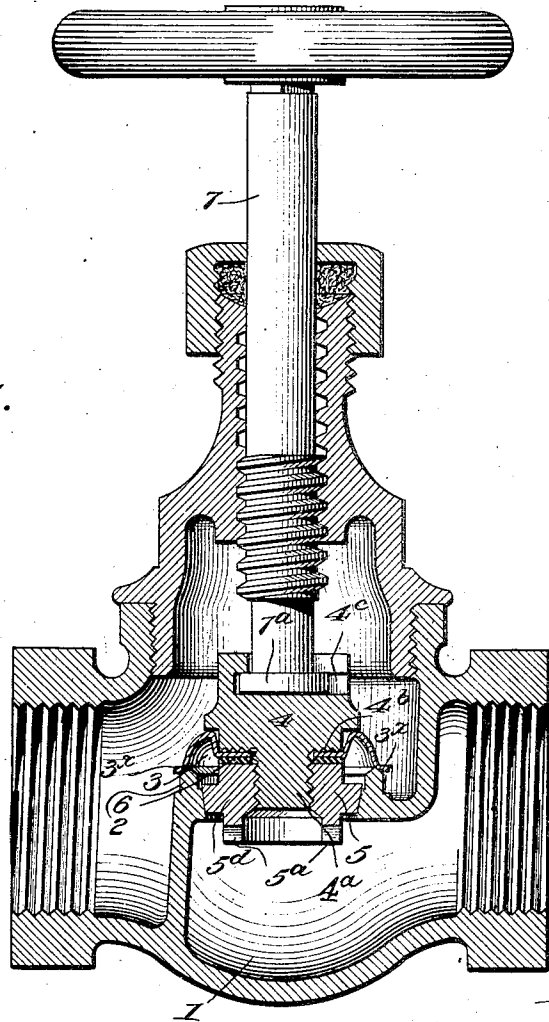

*Fig. 3.*

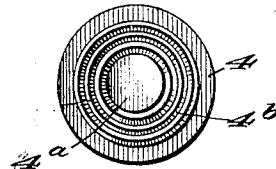

*my*  
 Fig. 2.

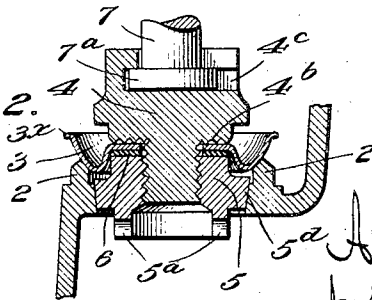

Witnesses:

Robt. N. Burton  
 J S Abbott

Inventor:

Alva C. Ricksecker Jr  
 by Burton & Burton  
 his attys

# UNITED STATES PATENT OFFICE.

ALVA C. RICKSECKER, JR., OF CHICAGO, ILLINOIS, ASSIGNOR, BY MESNE ASSIGNMENTS TO AJAX VALVE COMPANY, OF CHICAGO, ILLINOIS, A CORPORATION OF NEW JERSEY.

## VALVE.

No. 908,138.

Specification of Letters Patent.

Patented Dec. 29, 1909.

Application filed May 6, 1905. Serial No. 259,149.

*To all whom it may concern:*

Be it known that I, ALVA C. RICKSECKER, Jr., a citizen of the United States, residing at Chicago, in the county of Cook and State of Illinois, have invented new and useful Improvements in Valves, of which the following is a specification, reference being had to the accompanying drawings, forming a part thereof.

The purpose of this invention is to provide an improved construction of valve in which the disk shall be adapted to accommodate itself to the seat by virtue of the elasticity and flexibility of the disk, and which shall, notwithstanding such elasticity and flexibility, be adapted to sustain and resist high pressure when seated.

It consists of the features of construction set out in the claims.

In the drawings:—Figure 1 is an axial section of a globe valve embodying my invention. Fig. 2 is a detail section of the valve and its seat, showing the valve disk in reversed position for seating interiorly instead of exteriorly of the seat. Fig. 3 is an end view of the disk holder with the disk and retaining nut removed.

My invention comprises a seating element of the valve, which, according to the usage of the art, is hereinafter named the valve disk, although its form is not strictly disk-like; this form being an annulus somewhat flexible in a plane transverse to the axis, so that by expanding in one diameter and contracting in another it may accommodate itself by its flexibility to a seat not perfectly circular which is encountered either inside or outside such annulus. This annulus is dished or flaring and seats after the manner of a hood or cap on the valve seat.

In Fig. 1, my invention is shown applied to a valve of the usual construction as to the body, 1, and in which the seat, 2, is adapted to be encountered by the disk, either on the inner or on the outer side. The valve disk is made preferably of sheet metal struck up or spun into desired form. The valve disk, 3, has its seating portion constituting a peripheral annulus, the entire disk being in the form of a cup or cap with a central aperture in the bottom by means of which it is adapted to pass on to the disk holder or terminal

element, 4, of the stem, said holder having a threaded terminal portion, 4<sup>a</sup>, which passes through the central aperture of the disk, and having also an annular platform or shoulder, 4<sup>b</sup>, surrounding said central threaded portion, said platform or shoulder being annularly corrugated as shown, the corrugations being somewhat acute, so that the disk when clamped on the shoulder against such acute corrugations is slightly impressed or indented by the latter and there is thereby produced a fluid-tight joint between the disk and the holder in the annular area about the central terminal, 4<sup>a</sup>, on to which there is screwed the binding nut, 5. A gasket, 6, may be interposed between the binding nut and the annular portion of the disk against which the nut operates to clamp it to the corrugated seat. Such gasket operates in addition to the corrugated platform or shoulder to make a fluid-tight joint which prevents passage of fluid around the terminal, 4<sup>a</sup>. The disk-holder, 4, is preferably connected to the threaded stem, 7, so as to be readily detachable and to permit the stem to rotate without rotating the holder and disk. That is to say, the holder is swiveled to the stem. The mode of attachment illustrated is familiar, the stem, 7, having an enlargement or flange, 7<sup>a</sup>, at the end which engages the under-cut slot, 4<sup>c</sup>, of the holder, the slot being extended to one side so that the head may be entered on the stem.

The more usual method of using a valve disk of the construction shown is so that it encounters the seat on the outer side of the latter and the inner side of the seating annulus of the disk; but whether used in the form of an exteriorly or interiorly seating device, it has the quality of accommodating itself to a seat which may not be perfectly circular, such accommodation resulting from the flexibility of the annulus in a plane transverse to its axis. In addition to accommodating itself to the seat by reason of its flexibility, such annular disk has some capacity for accommodating itself by reason of its elastic extensibility and compressibility; that is to say, when it seats exteriorly it will stretch slightly circumferentially in order to reach the seat at all points, but when applied interiorly it will be slightly com-

pressed, yielding elastically to accommodate the seat.

In Fig. 2, the valve disk is shown adapted to be reversed so as to present either side to the corresponding side of the valve seat. The seating annulus of the disk is flaring and radially curved, and the seat is sloped, both at the inner and the outer side, so that the disk may be mounted on the holder either with the concave inner side or the convex outer side facing the seat. In said Fig. 2, the latter adjustment is represented, the seat being encountered on its inner sloping side by the outer convex side of the annulus.

In Fig. 1 the disk and seat are shown with the disk mounted in reverse position, so that the concave inner side of the disk encounters the outer sloping side of the seat, and the encounter of the inner side of the disk with the outer side of the valve seat is made at the inner corner of the peripheral edge of the disk, that corner being slightly rounded or beveled for such encounter.

In Figs. 1 and 2 there is shown a reinforcing flange or bead 3<sup>x</sup> formed at the periphery of the annular disk, projecting outward to strengthen it against the possibility of rupture when forced too severely upon the seat. This disk somewhat diminishes both the flexibility and the extensibility of the periphery, but still leaves those qualities sufficiently present to adapt the disk to perform all the functions above described.

In Figs. 1 and 2, there is illustrated also another feature relating to the form of the nut for securing the disk to the holder and the fluid-way within the valve seat. This nut, 5, is substantially cylindrical, except as modified for a special purpose, but is modified as shown in Figs. 1 and 2 for a specific purpose hereinafter explained. It is provided with notches, 5<sup>a</sup>, 5<sup>b</sup>, constituting practically a diametric slot to engage a device in the nature of a screw driver or a straight key, as will be readily understood without further description. A nut of this general character with a slight modification may be made to serve a secondary purpose of graduating the opening of the valve, or making a valve which has the effect of a very slow taper at its seat without the danger of becoming wedged unreleasably in its seat. This modification is illustrated in Figs. 1 and 2, in which the nut has an enlargement back of the notched or slotted end, as seen at 5<sup>a</sup>, which is slightly tapered and adapted to fit the correspondingly slightly tapered interior surface of the fluid-way through the valve seat. The valve disk will be shaped and proportioned with respect to the point at which it encounters the seat so that such encounter will occur before the slightly

tapered portion, 5<sup>a</sup>, of the nut is actually seated on said wall of the fluid-way, and so that the valve disk may be forced on to the seat sufficiently to cause it to accommodate itself to the latter in case the seat is not perfectly circular, and may be stretched or compressed slightly for the purpose of such accommodation, without wedging the tapered portion of the nut in the fluid-way, the intention being that mere contact of the two slightly tapered surfaces shall be effected by the time the disk has been forced sufficiently to accommodate itself perfectly to the seat. In opening a valve of this construction, it will be seen that the fluid-way will be unclosed very gradually, according to the gradual taper of the nut and fluid-way, until said enlarged and slightly tapered portion, 5<sup>a</sup>, of the nut is completely withdrawn from the corresponding portion of the fluid-way, and that, during that portion of the opening movement, the valve disk will be withdrawing directly from the seat and the valve will be opened widely by very short movement of the valve after that point is reached, thus giving the advantage of a very gradually opening valve at the commencing of the opening movement, with the advantage of a very rapidly opening valve at a subsequent part of the movement. It will be seen that this construction of the nut and fluid-way is available whichever way the disk is mounted,—that is, whether as in Fig. 1, seating on the concave side exterior to the seat, or as in Fig. 2, seating on the convex side within the seat.

I claim:—

1. In a valve, a thin metal disk having a flaring or dished outer annular portion, in combination with a holder upon which the disk is adapted to be mounted with either face of its flaring or dished portion outward at will; means for binding the disk to the holder, and a seat adapted to be encountered at its inner circumference by the outer side of the disk in one position of the latter, and at its outer circumference by the inner side of the disk at the reverse position of the disk.

2. In a valve, in combination with a seat having the fluid-way interiorly slightly tapered, a thin metal valve disk having a flaring or dished outer annular portion for encountering the seat; said seat and said annular portion of the disk being relatively formed to operate wedge-wise when forced together; a holder on which the disk is mounted, and a nut for binding the disk to the holder about the center, said nut having a frusto-conical portion conformed substantially in taper to the taper of the fluid-way, and adapted to occupy the latter when the disk is in full seating position.

3. In a valve, a thin metal valve disk hav-  
ing an annular portion dished or flaring and  
radially curved; a holder and means for  
binding the disk to the holder with the con-  
cave side of such annular portion facing the  
5 seat, the disk being reinforced at its outer  
circumference to prevent stretching thereat.

In testimony whereof, I have hereunto set  
my hand, this 25th day of April, 1905, at  
Chicago, Illinois.

ALVA C. RICKSECKER, JR.

In the presence of—

FRANK L. SMITH,

CHAS. S. BURTON.