

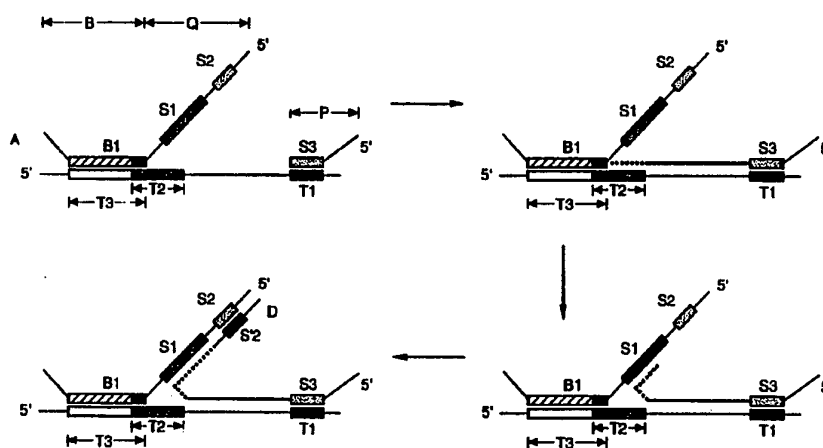

INTERNATIONAL APPLICATION PUBLISHED UNDER THE PATENT COOPERATION TREATY (PCT)

(51) International Patent Classification ⁵ : C12Q 1/68	A1	(11) International Publication Number: WO 94/03637 (43) International Publication Date: 17 February 1994 (17.02.94)
(21) International Application Number: PCT/US93/07051 (22) International Filing Date: 30 July 1993 (30.07.93) (30) Priority data: 07/923,079 31 July 1992 (31.07.92) US (71) Applicant: SYNTEX (USA) INC. [US/US]; 3401 Hillview Avenue, Palo Alto, CA 94304 (US). (72) Inventors: LANEY, Maureen ; 445 Wilton Avenue, Palo Alto, CA 94306 (US). CHEN, Yan ; 914 Colorado Avenue, Palo Alto, CA 94303 (US). ULLMAN, Edwin, F. ; 135 Shelby Lane, Atherton, CA 94025 (US). HAHNENBERGER, Karen, N. ; 19940 Portal Plaza, Cupertino, CA 95014 (US).		(74) Agents: CHOW, Y., Ping et al. ; Syntex (U.S.A.) Inc., 3401 Hillview Avenue, Palo Alto, CA 94304 (US). (81) Designated States: CA, JP, European patent (AT, BE, CH, DE, DK, ES, FR, GB, GR, IE, IT, LU, MC, NL, PT, SE). Published <i>With international search report.</i> <i>Before the expiration of the time limit for amending the claims and to be republished in the event of the receipt of amendments.</i>

(54) Title: METHOD FOR INTRODUCING DEFINED SEQUENCES AT THE 3' END OF POLYNUCLEOTIDES**(57) Abstract**

A method is disclosed for extending a primer to produce a single stranded polydeoxynucleotide that has two or more defined sequences. A combination is provided which comprises a template polynucleotide, a blocker polynucleotide, a primer polynucleotide and a polynucleotide Q. The template polynucleotide has three sequences T1, T2 and T3 wherein T1 is non-contiguous and 3' of T3 and wherein the 5' end of T3 is 5' of the 5' end of T2. The primer polynucleotide has a second defined sequence at its 3' end that is hybridizable with T1. The blocker polynucleotide has sequence B1 that is hybridizable with T3. Polynucleotide Q has sequences S1 and S2 wherein S1 is 3' of S2 and homologous with T2 and S2 is complementary to a first defined sequence that is to be introduced at the 3' end of the polynucleotide primer, when it is extended during the method of the invention. Polynucleotide Q is either attached to the 5' end of the blocker polynucleotide or present as a separate reagent. The primer is extended along the template polynucleotide and along at least a portion of sequence T2 and thereafter along the polynucleotide Q to give a single stranded polynucleotide having two or more defined sequences.

FOR THE PURPOSES OF INFORMATION ONLY

Codes used to identify States party to the PCT on the front pages of pamphlets publishing international applications under the PCT.

AT	Austria	FR	France	MR	Mauritania
AU	Australia	GA	Gabon	MW	Malawi
BB	Barbados	GB	United Kingdom	NE	Niger
BE	Belgium	GN	Guinea	NL	Netherlands
BF	Burkina Faso	GR	Greece	NO	Norway
BG	Bulgaria	HU	Hungary	NZ	New Zealand
BJ	Benin	IE	Ireland	PL	Poland
BR	Brazil	IT	Italy	PT	Portugal
BY	Belarus	JP	Japan	RO	Romania
CA	Canada	KP	Democratic People's Republic of Korea	RU	Russian Federation
CF	Central African Republic	KR	Republic of Korea	SD	Sudan
CG	Congo	KZ	Kazakhstan	SE	Sweden
CH	Switzerland	LI	Liechtenstein	SI	Slovenia
CI	Côte d'Ivoire	LK	Sri Lanka	SK	Slovak Republic
CM	Cameroon	LU	Luxembourg	SN	Senegal
CN	China	LV	Latvia	TD	Chad
CS	Czechoslovakia	MC	Monaco	TG	Togo
CZ	Czech Republic	MG	Madagascar	UA	Ukraine
DE	Germany	ML	Mali	US	United States of America
DK	Denmark	MN	Mongolia	UZ	Uzbekistan
ES	Spain			VN	Viet Nam
FI	Finland				

-1-

METHOD FOR INTRODUCING DEFINED SEQUENCES AT
THE 3' END OF POLYNUCLEOTIDES

5

This invention relates to the use of nucleic acid hybridisation.

Nucleic acid hybridization has great potential in diagnosing disease states associated with unique nucleic acid sequences.

10 In one embodiment of the present invention a method is described for forming from a primer and a single stranded template polynucleotide a single stranded polydeoxynucleotide having two or more defined sequences. The method comprises: (a) hybridizing a sequence B1 of a blocker polynucleotide to a complementary sequence T3 within a template polynucleotide ("template"), wherein the 5' end of T3 is 5' of the 5' end
15 of a sequence T2, T2 and T3 being 5' to and non-contiguous with a sequence T1 of the template, (b) hybridizing the 3' end of a polynucleotide primer, comprising a second defined sequence, to T1 wherein step (b) is performed prior to, after, or simultaneously with step (a), and (c) extending the primer along the template and along at least a portion of T2. Thereafter,
20 the primer extends along a polynucleotide Q having sequences S1 and S2 wherein S1 is 3' of S2 and homologous with T2. An extended primer is obtained having a first defined nucleic acid sequence at its 3' end that is complementary to S2. Polynucleotide Q is either attached to the 5' end of the blocker polynucleotide or is present as a separate reagent.

25 In another embodiment of a method in accordance with the invention, a single stranded polydeoxynucleotide having two segments that are non-contiguous and complementary with each other is produced. A combination is formed comprising (a) a template polynucleotide having three sequences T1, T2 and T3 wherein T1 is non-contiguous and 3' of T2 and T3,
30 and the 3' end of T3 is contiguous with or lies within T2, (b) a primer polynucleotide whose 3' end is hybridizable with T1, (c) a blocker polynucleotide with sequence B1, that is hybridizable with sequence T3, and (d) a polynucleotide Q having sequence S1 and S2. Polynucleotide Q is either attached to the 5' end of (in other words is a part of) the blocker
35 polynucleotide or present as a separate reagent. S1 is 3' of S2 and homologous to T2 and S2 is a sequence that is homologous to at least the 3' end of primer polynucleotide. The primer is extended along the template polynucleotide and along at least a portion of T2 and thereafter along polynucleotide Q. The method finds particular application, for example, in
40 single primer amplification assays (see for instance EP-A-0379 369).

Another embodiment of the invention is a method for forming multiple copies of a target polynucleotide. The method comprises: (a) combining in
45 a medium a template polynucleotide having three sequences T1, T2 and T3 wherein T1 is non-contiguous and 3' of T2 and T3 and wherein the 3' end of T3 is contiguous with or lies within T2 and wherein the target sequence is located between T1 and T3, (2) a primer polynucleotide whose 3' end is hybridizable with T1, (3) a blocker polynucleotide with sequence B1,

-2-

wherein B1 is hybridizable with T3, (4) a polynucleotide Q having sequences S1 and S2 wherein Q is either attached to the 5' end of the blocker polynucleotide or present as a separate reagent and wherein S1 is 3' of S2 and homologous to T2 and wherein S2 is a sequence that is homologous to at least the 3' end of the primer polynucleotide, (5) DNA polymerase and (6) deoxynucleoside triphosphates under conditions wherein: (A) the blocker becomes hybridized to the sequence T3 of the template polynucleotide, (B) the primer becomes hybridized to the sequence T1 and is extended along the target sequence of the template polynucleotide and along at least a portion of T2 and thereafter along polynucleotide Q to form a duplex, (C) the extended primer is dissociated from the duplex, and (D) the primer hybridizes with and is extended along the extended primer to form a duplex comprising extended primer containing a copy of the target sequence and steps (C) and (D) are repeated.

In another embodiment the presence of a polynucleotide analyte, comprising a template sequence, in a medium suspected of containing the polynucleotide analyte is detected. The template sequence has three sequences T1, T2 and T3 wherein T1 is non-contiguous with and 3' of T2 and T3 and wherein the 5' end of T3 is 5' of the 5' end of T2. The medium is combined with (1) a primer polynucleotide whose 3' end is hybridizable with T1, (2) a blocker polynucleotide with sequence B1, wherein B1 is hybridizable with T3, (3) a polynucleotide Q having sequences S1 and S2 wherein Q is attached to the 5' end of the blocker polynucleotide or is present as a separate reagent and wherein S1 is 3' of S2 and is homologous to T2 and wherein S2 is homologous to at least the 3' end of the primer polynucleotide, (4) DNA polymerase and (5) deoxynucleoside triphosphates. Conditions are chosen wherein: (A) the blocker becomes hybridized to the template sequence, (B) the primer becomes hybridized with and is extended along the template sequence and along at least a portion of T2 and thereafter along polynucleotide Q to form a duplex, (C) the extended primer is dissociated from the duplex, and (D) the primer hybridizes with and is extended along the extended primer to form a duplex comprising extended primer and steps (C) and (D) are repeated. An examination is then carried out for the presence of the extended primer whose presence is determinative of the presence of the polynucleotide analyte. Alternatively in the above embodiment, T1 is non-contiguous with and 3' of said T2 and T3 and the 3' end of said T3 is contiguous with or lies within said T2.

Another embodiment of the present invention concerns a method for producing from a primer polynucleotide a single stranded polydeoxynucleotide having two segments that are non-contiguous and complementary with each other. The method comprises the steps of: (a) providing in combination (1) a template polynucleotide having three sequences T1, T2 and T3 wherein T1 is non-contiguous and 3' of T2 and T3 and the 3' end of T3 is contiguous with or lies within T2 and T2 is comprised of a restriction site at the 5' end of the region homologous to S1

of a polynucleotide Q, (2) a polynucleotide primer whose 3' end is hybridizable with T1, (3) a blocker polynucleotide with sequence B1, wherein B1 is hybridizable with T3, and (4) polynucleotide Q having sequence S1 and sequence S2 wherein Q is either attached to the 5' end of the blocker polynucleotide or present as a separate reagent and wherein S1 is 3' of S2 and homologous to T2 and wherein S2 is a sequence that is homologous to at least the 3' end of the primer polynucleotide, and (b) subjecting the combination to conditions for extending the primer along the template polynucleotide and along at least a portion of T2, cutting the template polynucleotide at the restriction site, hybridizing the partially extended primer to S1 and extending the primer along polynucleotide Q.

Another embodiment of the present invention concerns a method for producing from a polynucleotide primer a single stranded polydeoxynucleotide having two different defined sequences P1 and P'2. In one embodiment the single stranded polydeoxynucleotide is capable of being amplified by the polymerase chain reaction. The method comprises the steps of: (a) providing in combination (1) a template polynucleotide (template) having three sequences T1, T2 and T3 wherein T1 is non-contiguous with and 3' of T2 and T3 and the 3' end of T3 is contiguous with or lies within T2, (2) a polynucleotide primer P1 whose 3' end is hybridizable with T1, (3) a blocker polynucleotide with sequence B1, wherein B1 is hybridizable with T3, and (4) polynucleotide Q having sequences S1 and S2, wherein Q is either attached to the 5' end of the blocker polynucleotide or present as a separate reagent and wherein S1 is 3' of S2 and homologous to T2 and wherein S2 is complementary to P2, and (b) subjecting the combination to conditions for extending the primer P1 along the template and along at least a portion of T2 and thereafter along polynucleotide Q. A second single stranded polydeoxynucleotide is formed by hybridizing a polydeoxynucleotide primer P2 to sequence P'2 of the extended primer disassociated from its duplex and extending P2 along the first extended primer and dissociating the second extended primer from its duplex. The second extended primer is characterized by having a sequence P'1 that is 3' of sequence P2 and is capable of hybridizing to primer P1. The resulting two single stranded polynucleotides (fully extended primers P1 and P2) can then be amplified by the polymerase chain reaction.

Another aspect of the present invention concerns a composition comprising a single strand of DNA comprised of a sequence T3 and a sequence T2 wherein the 3' end of T3 is contiguous with the 5' end of T2. The single strand is complexed to a blocker DNA sequence comprised of a sequence B1 complementary to T3 and a sequence S1 that is 5' of B1 and homologous to T2. The compositions can also include a primer polynucleotide having a sequence at its 3' end complexed with a sequence T1 in the single strand of DNA.

The invention further includes kits comprising in packaged combination (a) a primer polynucleotide having a sequence at its 3' end

hybridizable with a first sequence T1 in a template polynucleotide, (b) a blocker polynucleotide having a sequence B1, wherein B1 is hybridizable with a sequence T3 in the template polynucleotide and wherein T3 is 3' of T1 and the 5' end of T3 is 5' of the 5' end of a sequence T2 and (c) a
5 polynucleotide Q having sequences S1 and S2 wherein S1 is 3' of S2 and homologous to T2 in the template polynucleotide and wherein S2 is a sequence that is homologous to at least the 3' end portion of the primer.

The invention further includes kits comprising in packaged combination (a) a primer polynucleotide having a sequence at its 3' end
10 hybridizable with a first sequence T1 in a template polynucleotide, (b) a blocker polynucleotide having a sequence B1, wherein B1 is hybridizable with a sequence T3 in the template polynucleotide wherein T3 is 3' of T1 and the 5' end of T3 is 5' of the 5' end of a sequence T2 and (c) a
15 polynucleotide Q having sequences S1 and S2 wherein S1 is 3' of S2 and homologous to T2 in the template polynucleotide and wherein S2 is a sequence that is homologous to at least the 3' end portion of a second primer.

Brief Description of the Drawings

20 Figures 1-7 are schematics of different embodiments in accordance with the present invention.

Figures 8-16 are visualizations of gels on which reaction products from the EXAMPLES were run.

25

Description of the Specific Embodiments

The present method allows extension of a polydeoxynucleotide primer along a single stranded (ss) template polynucleotide sequence and
30 thereafter along another ss polynucleotide to produce a ss product polynucleotide having two or more defined sequences.

In the production of the above polynucleotide the following steps are performed: (a) a sequence B1 of a blocker polynucleotide is hybridized to a complementary sequence T3 of a template polynucleotide ("template"),
35 wherein the 5' end of T3 is 5' of the 5' end of a sequence T2, T2 and T3 being 5' to and non-contiguous with a sequence T1, (b) the 3' end of a polynucleotide primer comprising a second defined sequence is hybridized to T1 wherein step (b) is performed prior to, after, or simultaneously with step (a), and (c) the primer is extended along the template and along at
40 least a portion of T2, preferably along at least 8 bases of T2, more preferably up to the blocker polynucleotide and thereafter along a polynucleotide Q having sequences S1 and S2 wherein S1 is 3' of S2 and homologous with T2 to give an extended primer having a first defined nucleic acid sequence at its 3' end that is complementary to S2 and a
45 second defined sequence that corresponds to the primer, wherein

polynucleotide Q is either attached to the 5' end of (i.e., is a part of) the blocker polynucleotide or is present as a separate reagent.

One particular aspect of the invention allows for the production of a single stranded polydeoxynucleotide having a structure capable of intramolecular base-pairing, i.e., having two segments that are non-contiguous and complementary with each other, otherwise known as an inverted repeat, which can form a stem loop structure. The method has particular application in the area of single primer amplification, in which a target polynucleotide sequence in a sample is amplified when such target polynucleotide sequence has a structure capable of intramolecular base-pairing or can be converted to such a structure. The present method provides a highly convenient method for converting a polynucleotide sequence of interest to a target polynucleotide sequence having an intramolecular structure capable of base-pairing while minimizing the number of reagents and steps required.

Before proceeding further with a description of the specific embodiments of the present invention, a number of terms will be defined.

Polynucleotide analyte--a compound or composition to be measured that is a polymeric nucleotide or a portion of a polymeric nucleotide, which in the intact natural state can have about 20 to 500,000 or more nucleotides and in an isolated state can have about 30 to 50,000 or more nucleotides, usually about 100 to 20,000 nucleotides, more frequently 500 to 10,000 nucleotides. It is thus obvious that isolation of the analyte from the natural state often results in fragmentation of the polymeric nucleotide. The polynucleotide analytes include nucleic acids from any source in purified or unpurified form including DNA (dsDNA and ssDNA) and RNA, including t-RNA, m-RNA, r-RNA, mitochondrial DNA and RNA, chloroplast DNA and RNA, DNA-RNA hybrids, or mixtures thereof, genes, chromosomes, plasmids, the genomes of biological material such as microorganisms, e.g., bacteria, yeasts, viruses, viroids, molds, fungi, plants, animals, humans, and fragments thereof, and the like. The polynucleotide analyte can be only a minor fraction of a complex mixture such as a biological sample. The analyte can be obtained from various biological material by procedures well known in the art. Some examples of such biological material by way of illustration and not limitation are disclosed in Table I below.

Table I

Microorganisms of interest include:

Corynebacteria
Corynebacterium diphtheria
Pneumococci
Diplococcus pneumoniae
Streptococci
Streptococcus pyrogenes
Streptococcus salivarius

	<u>Staphylococci</u>	
	<i>Staphylococcus aureus</i>	
	<i>Staphylococcus albus</i>	
	<u>Neisseria</u>	
5	<i>Neisseria meningitidis</i>	
	<i>Neisseria gonorrhoea</i>	
	<u>Enterobacteriaceae</u>	
	<i>Escherichia coli</i>	
	<i>Aerobacter aerogenes</i>	The colliform
10	<i>Klebsiella pneumoniae</i>	bacteria
	<i>Salmonella typhosa</i>	
	<i>Salmonella choleraesuis</i>	The Salmonellae
	<i>Salmonella typhimurium</i>	
	<i>Shigella dysenteriae</i>	
15	<i>Shigella schmitzii</i>	
	<i>Shigella arabinotarda</i>	
		The Shigellae
	<i>Shigella flexneri</i>	
	<i>Shigella boydii</i>	
20	<i>Shigella sonnei</i>	
	<u>Other enteric bacilli</u>	
	<i>Proteus vulgaris</i>	
	<i>Proteus mirabilis</i>	Proteus species
	<i>Proteus morgani</i>	
25	<i>Pseudomonas aeruginosa</i>	
	<i>Alcaligenes faecalis</i>	
	<i>Vibrio cholerae</i>	
	<u>Hemophilus-Bordetella group</u>	
	<i>Hemophilus influenzae, H. ducryi</i>	<i>Rhizopus oryzae</i>
30	<i>Hemophilus hemophilus</i>	<i>Rhizopus arrhizua</i> <i>Phycomycetes</i>
	<i>Hemophilus aegypticus</i>	<i>Rhizopus nigricans</i>
	<i>Hemophilus parainfluenza</i>	<i>Sporotrichum schenkii</i>
	<i>Bordetella pertussis</i>	<i>Fonsecaea pedrosoi</i>
	<u>Pasteurellae</u>	<i>Fonsecaea compact</i>
35	<i>Pasteurella pestis</i>	<i>Fonsecaea dermatidis</i>
	<i>Pasteurella tularensis</i>	<i>Cladosporium carrionii</i>
	<u>Brucellae</u>	<i>Phialophora verrucosa</i>
	<i>Brucella melitensis</i>	<i>Aspergillus nidulans</i>
	<i>Brucella abortus</i>	<i>Madurella mycetomi</i>
40	<i>Brucella suis</i>	<i>Madurella grisea</i>
		<i>Allescheria boydii</i>
	<u>Aerobic Spore-forming Bacilli</u>	
	<i>Bacillus anthracis</i>	<i>Phialophora jeanselmei</i>
45	<i>Bacillus subtilis</i>	<i>Microsporum gypseum</i>
	<i>Bacillus megaterium</i>	<i>Trichophyton mentagrophytes</i>
	<i>Bacillus cereus</i>	<i>Keratinomyces ajelloi</i>
	<u>Anaerobic Spore-forming Bacilli</u>	<i>Microsporum canis</i>
	<i>Clostridium botulinum</i>	<i>Trichophyton rubrum</i>
50	<i>Clostridium tetani</i>	<i>Microsporum adouini</i>
	<i>Clostridium perfringens</i>	<u>Viruses</u>
	<i>Clostridium novyi</i>	Adenoviruses
	<i>Clostridium septicum</i>	<u>Herpes Viruses</u>
	<i>Clostridium histolyticum</i>	Herpes simplex
55	<i>Clostridium tertium</i>	Varicella (Chicken pox)
	<i>Clostridium bifermentans</i>	Herpes Zoster (Shingles)
	<i>Clostridium sporogenes</i>	Virus B
	<u>Mycobacteria</u>	Cytomegalovirus
	<i>Mycobacterium tuberculosis</i>	<u>Pox Viruses</u>
60	<i>hominis</i>	<i>Variola (smallpox)</i>
	<i>Mycobacterium bovis</i>	
	<i>Mycobacterium avium</i>	<i>Vaccinia</i>
	<i>Mycobacterium leprae</i>	<i>Poxvirus bovis</i>
	<i>Mycobacterium paratuberculosis</i>	<i>Paravaccinia</i>
65	<u>Actinomycetes (fungus-like bacteria)</u>	<i>Molluscum contagiosum</i>
	<i>Actinomyces Israeli</i>	<u>Picornaviruses</u>
	<i>Actinomyces bovis</i>	Poliovirus
		Coxsackievirus

	<i>Actinomyces naeslundii</i>	Echoviruses
	<i>Nocardia asteroides</i>	Rhinoviruses
	<i>Nocardia brasiliensis</i>	<u>Myxoviruses</u>
	<u>The Spirochetes</u>	Influenza(A, B, and C)
5	<i>Treponema pallidum</i> <i>Spirillum minus</i>	Parainfluenza (1-4)
	<i>Treponema pertenuae</i> <i>Streptobacillus</i> <i>monociliformis</i>	Mumps Virus
	<i>Treponema carateum</i>	Newcastle Disease Virus
	<i>Borrelia recurrentis</i>	Measles Virus
10	<i>Leptospira icterohemorrhagiae</i>	Rinderpest Virus
	<i>Leptospira canicola</i>	Canine Distemper Virus
	<u>Trypanosomes</u>	Respiratory Syncytial Virus
	<u>Mycoplasmas</u>	Rubella Virus
	<i>Mycoplasma pneumoniae</i>	<u>Arboviruses</u>
15	<u>Other pathogens</u>	Eastern Equine Encephalitis
	Virus	Western Equine Encephalitis
	<i>Listeria monocytogenes</i>	Sindbis Virus
	Virus	Chikungunya Virus
20	<i>Erysipelothrix rhusiopathiae</i>	Semliki Forest Virus
	<i>Streptobacillus moniliformis</i>	Mayora Virus
	<i>Donovania granulomatis</i>	St. Louis Encephalitis Virus
	<i>Bartonella bacilliformis</i>	California Encephalitis Virus
	<u>Rickettsiae (bacteria-like</u> <u>parasites)</u>	Colorado Tick Fever Virus
25	<i>Rickettsia prowazekii</i>	Yellow Fever Virus
	<i>Rickettsia mooseri</i>	Dengue Virus
	<i>Rickettsia rickettsii</i>	<u>Reoviruses</u>
	<i>Rickettsia conori</i>	Reovirus Types 1-3
	<i>Rickettsia australis</i>	<u>Retroviruses</u>
30	<i>Rickettsia sibiricus</i>	Human Immunodeficiency Viruses
	<i>Rickettsia akari</i>	Human T-cell Lymphotropic Virus I & II (HTLV)
	(HIV)	<u>Hepatitis</u>
	<i>Rickettsia tsutsugamushi</i>	Hepatitis A Virus
35	<i>Rickettsia burnetti</i>	Hepatitis B Virus
	<i>Rickettsia quintana</i>	Hepatitis nonA-nonB Virus
	<u>Chlamydia (unclassifiable parasites</u> <u>bacterial/viral)</u>	<u>Tumor Viruses</u>
40	Chlamydia agents (naming uncertain)	Rauscher Leukemia Virus
	<u>Fungi</u>	Gross Virus
	<i>Cryptococcus neoformans</i>	Maloney Leukemia Virus
	<i>Blastomyces dermatidis</i>	Human Papilloma Virus
	<i>Hisoplasma capsulatum</i>	
45	<i>Coccidioides immitis</i>	
	<i>Paracoccidioides brasiliensis</i>	
	<i>Candida albicans</i>	
	<i>Aspergillus fumigatus</i>	
50	<i>Mucor corymbifer (Absidia corymbifera)</i>	

The polynucleotide analyte, where appropriate, may be treated to cleave the analyte to obtain a template polynucleotide that contains a target polynucleotide sequence, for example, by shearing or by treatment with a restriction endonuclease or other site specific chemical cleavage method. However, it is an advantage of the present invention that the polynucleotide analyte can be used in its isolated state without further cleavage.

For purposes of this invention, the polynucleotide analyte, or a cleaved fragment obtained from the polynucleotide analyte, is usually at least partially denatured or single stranded or treated to render it denatured or single stranded. Such treatments are well-known in the art and include, for instance, heat or alkali treatment. For example, double stranded DNA, when heated at 90-100° C. for a period of 10-20 seconds or more, produces denatured material.

Template polynucleotide-- a sequence of nucleotides, usually existing within a polynucleotide analyte, the identity of which is known to an extent sufficient to allow preparation of a polynucleotide primer, a blocker polynucleotide, and the sequence S1 in polynucleotide Q. The polynucleotide primer should be capable of hybridizing with a sequence T1 within such template polynucleotide, usually at least a 10 nucleotide segment at the 3'-end thereof and preferably at least a 15, frequently a 20 to 100 or more nucleotide segment thereof. A sequence B1 of a blocker polynucleotide should be capable of hybridizing with a sequence T3 within such template polynucleotide, usually at least a 10 nucleotide segment at the 5'-end thereof and preferably at least a 15, frequently a 20 to 100 or more nucleotide segment thereof. The template polynucleotide has three nucleotide sequences T1, T2 and T3, wherein T1 is non-contiguous and 3' of T2 and T3 and is the aforesaid portion capable of hybridizing to the polynucleotide primer. The 5' end of sequence T3 is 5' of the 5' end of sequence T2, preferably at least 10 to 15 bases, of the 5' end of sequence T2, and preferably its 3' end is contiguous with or lies within sequence T2. When the 3' end of T3 is not contiguous with or within sequence T2, it is usually less than 10 bases 5' of T2, frequently less than 5 bases 5' of T2. Sequence T2 is homologous to sequence S1 in polynucleotide Q. The target polynucleotide sequence is located between T1 and T3.

The template polynucleotide is usually a part of the polynucleotide analyte. The template polynucleotide is generally a fraction of a larger molecule but it may be substantially the entire molecule. The number of nucleotides in the template polynucleotide is determined from the sum of the nucleotides in T1, T3 and the target polynucleotide sequence. Generally, the template polynucleotide is obtained from the polynucleotide analyte by any procedure that is capable of generating smaller polynucleotides from larger polynucleotides such as, for example, digestion of the larger polynucleotide with a restriction enzyme or other site-specific chemical cleavage agent, mechanical shearing, and so forth.

The polynucleotide sequence T2 of the template polynucleotide, which is homologous with sequence S1 of the polynucleotide Q, is at least 4 nucleotides, preferably 10-30, and may be 30-100 deoxynucleotides, in length. In general T2 will be about 10 to 40 deoxynucleotides.

5 Often at least a five base sequence within the 15 bases at the 3' end of said T3 is comprised of at least 80% of G and C nucleotides.

Target polynucleotide sequence -- a sequence of nucleotides to be identified, either RNA or DNA, existing within a template polynucleotide between sequences T1 and T3 of the template polynucleotide employed in the present invention. The target polynucleotide sequence is at least 20 nucleotides, usually at least 50, frequently 200-4000 nucleotides, in length. Preferably the target polynucleotide sequence is about 200 to 1200 deoxynucleotides.

15 The minimum number of nucleotides in the target polynucleotide sequence is selected to assure that the presence of target polynucleotide sequence in a sample is a specific indicator of the presence of polynucleotide analyte in a sample. Very roughly, the target polynucleotide sequence length is usually greater than about $1.6 \log L$ nucleotides where L is the number of base pairs in the genome of the biologic source of the sample. The maximum number of nucleotides in the target polynucleotide sequence is normally governed by the length of the polynucleotide analyte, and its tendency to be broken by shearing, or other processes during isolation and any procedures required to prepare the sample for assay and the efficiency of detection and/or amplification of the sequence.

25 Single stranded (ss) polydeoxynucleotide sequence -- a sequence of deoxynucleotides that is formed as a result of the present invention. It is normally comprised of at least two defined segments or flanking sequences that are non-contiguous with each other. The first and second defined segments or flanking sequences are at the 3'-end and 5'-end of the ss polydeoxynucleotide sequence. The first defined sequence may be complementary to the second defined sequence and/or the defined sequences may contain one or more sequences that, when bound to their complementary sequences, are specific binding sites for receptors such as repressors, restriction enzymes, and the like. The first and the second sequence each comprises at least 10, preferably at least 15, deoxynucleotides, and/or derivatives thereof.

30 The single stranded polydeoxynucleotide sequence usually contains from 40 to 4000 deoxynucleotides, preferably 100 to 2000 deoxynucleotides, more preferably 250 to 1250 deoxynucleotides.

Polynucleotide primer -- a polynucleotide, usually a synthetic polynucleotide, which is single stranded, containing a sequence at its 3'-end that is capable of hybridizing with sequence T1, and that is preferably complementary to T1 of the template polynucleotide sequence. Although the nucleotide at the 3' end of the polynucleotide primer is

45

usually a deoxynucleotide, the primer may comprise modified bases such as phosphorothioates, methylated bases, phosphonates and the like and may also comprise ribonucleotides. The number of nucleotides in the sequence of the polynucleotide primer hybridizable with T1 should be such that stringency conditions used to hybridize the polynucleotide primer to T1 prevents excessive random non-specific hybridization. The number of nucleotides in the polynucleotide primer is at least as great as that in T1. The polynucleotide primer can contain at its 5' end nucleotides other than those in the sequence hybridizable with T1. These additional nucleotides can serve as ligands following extension and amplification of the extended primer and may, therefore, include sequences that bind to nucleic acid binding proteins, for example. They can also serve to facilitate amplification of the extended primer. For instance, they can be chosen so that the sequence is homologous to S2 and, thus, hybridizable to a polynucleotide primer that is employed in single primer amplification. The number of nucleotides other than those in the sequence hybridizable with T1 may vary widely, usually within the range of 0-2000, frequently 0-300, preferably 0-50. The primer may be labelled with a reporter molecule.

Partially Extended Primer -- a sequence of deoxynucleotides normally formed as a result of the extension of the polynucleotide primer along the template polynucleotide and along at least a portion of T2, before it switches strands to extend along the polynucleotide Q. When the 3' end of T3 has a sequence in common with the 5' end of T2, the 5' end of the blocker polynucleotide sequence B1 may be displaced during extension. The partially extended primer then consists at its 3' end of bases complementary to the 3' end of T3, the 5' end of T2, and the 5' end of S1 and homologous to the 5' end of the blocker sequence B1. Whether the 5' end of the blocker is displaced by DNA polymerase depends on the temperature at which the reaction is conducted, the base content and structure of the blocker polynucleotide and also on the type of DNA polymerase employed. For example, Vent DNA polymerase, while extending the 3' end of a primer, may displace the 5' end of a specific encountered DNA polymerase at 72°C, but not at 55°C. Therefore, with this DNA polymerase at 55°C polymerization or extension of the primer would stop at the 5' end of the blocker polynucleotide. In general, the primer extension will stop at the 5' end of the blocker more efficiently when the blocker sequence B1 is G-C rich and at lower temperatures. By controlling the temperature, the extending primer can be stopped at or near the 5' end of the blocker and then switch strands from the template to polynucleotide Q prior to further extension.

Deoxynucleoside triphosphates -- deoxynucleosides having a 5'-triphosphate substituent. The deoxynucleosides are pentose sugar derivatives of nitrogenous bases of either purine or pyrimidine derivation, covalently bonded to the 1'-carbon of the pentose sugar. The purine bases include adenine(A), guanine(G), inosine, and derivatives and analogs thereof. The pyrimidine bases include cytosine(C), thymine (T), uracil

-11-

(U), and derivatives and analogs thereof.

The derivatives and analogs include any substrate of a polydeoxynucleotide polymerase that can be incorporated into a polynucleotide through catalysis by such enzyme. The derivatives and analogs are exemplified by those that are recognized and polymerized by the enzyme in a similar manner to the underivitized nucleoside triphosphates. Examples of such derivatives or analogs by way of illustration and not limitation are those that are modified with a reporter group, biotinylated, amine modified, radiolabeled, alkylated, and the like and also include phosphorothioate, phosphite, ring atom modified derivatives, unnatural bases, and the like. The reporter group can be a fluorescent group such as fluorescein, a chemiluminescent group such as luminol, a terbium chelator such as N-(hydroxyethyl) ethylenediaminetriacetic acid that is capable of detection by delayed fluorescence, and the like.

Polydeoxynucleotide polymerase -- a catalyst, usually an enzyme, for forming an extension of the polynucleotide primer along a nucleic acid template that is comprised predominantly of deoxynucleotides. The polydeoxynucleotide polymerase is a template dependent polydeoxynucleotide polymerase and utilizes the deoxynucleoside triphosphates as building blocks for extending the 3' end of the polynucleotide primer to provide a sequence complementary with a single stranded polynucleotide sequence. Usually, the catalysts are enzymes, such as DNA polymerases, for example, T4 DNA polymerase, T7 DNA polymerase, Klenow fragment, reverse transcriptase, Vent DNA polymerase and Vent_R (recombinant) DNA polymerase, (Vent is a trademark of New England BioLabs, Beverly, MA), Pfu DNA polymerase, and the like, derived from any source such as cells, bacteria, for example, E. coli, plants, animals, virus, thermophilic bacteria, and so forth. Where the polynucleotide Q and/or target polynucleotide sequence is RNA, reverse transcriptase is used as at least one of the polynucleotide polymerases to facilitate extension of the primer along the polynucleotide Q and/or template. Of course, a polydeoxynucleotide polymerase used in the present invention for extending a primer along a single stranded template and thereafter along another single stranded polynucleotide should have little or no 5' - 3' exonuclease activity so as to minimize degradation of blocker polynucleotide. The 5' - 3' exonuclease activity of a polydeoxynucleotide polymerase is dependent on several factors such as pH, salt concentration, whether the template is double stranded or single stranded, and so forth, all of which are familiar to one skilled in the art. In general, the polydeoxynucleotide polymerase should not produce substantial degradation of blocker polynucleotide or primer.

Wholly or partially sequentially -- when the sample and various agents utilized in the present invention are combined other than concomitantly (simultaneously), one or more may be combined with one or more of the remaining agents to form a subcombination. Each subcombination can then be

subjected to one or more steps of the present method. Thus, each of the subcombinations can be incubated under conditions to achieve one or more of the desired results.

5 Hybridization (hybridizing) and binding--in the context of nucleotide sequences these terms are used interchangeably herein. The ability of two polynucleotide sequences to hybridize with each other is based in a large part on the degree of complementarity of the two polynucleotide sequences, which in turn is based on the fraction of matched complementary nucleotide pairs. The more nucleotides in a given sequence that are complementary to
10 another sequence, the more stringent the conditions can be for hybridization and the more specific will be the binding of the two sequences. Another factor to be considered is the nature of the nucleotide pairs that are opposite in the two strands. Some nucleotide pairs, such as G and C, have greater binding affinities for one another than do other
15 pairs. Increased stringency is achieved by elevating the temperature, increasing the ratio of cosolvents, lowering the salt concentration, and the like.

Homologous or substantially identical--In general, two polynucleotide sequences that are identical, or at least can each hybridize to the same
20 polynucleotide sequence, are homologous. The two sequences are homologous or substantially identical where the sequences each have at least 90%, preferably 100%, of the same or analogous base sequence where thymine (T) and uracil (U) are considered the same. Thus, the ribonucleotides A, U, C and G are taken as analogous to the deoxynucleotides dA, dT, dC, and dG,
25 respectively. Homologous sequences can both be DNA or one can be DNA and the other RNA.

Complementary--two sequences are complementary when the sequence of one can bind to the sequence of the other in an anti-parallel sense wherein the 3' end of each sequence binds to the 5' end of the other sequence and,
30 for example, among the natural bases each A, T(U), G, and C of one sequence is then aligned with a T(U), A, C, and G, respectively, of the other sequence.

Blocker polynucleotide-- a polynucleotide, either DNA or RNA, usually a synthetic polynucleotide that is single stranded, containing a sequence
35 B1 that is hybridizable, and preferably complementary, with sequence T3 of the template polynucleotide. The number and composition of nucleotides in the hybridizable sequence B1 of the blocker polynucleotide should be such that stringency conditions used to hybridize the blocker polynucleotide prevent excessive random non-specific hybridization. The number of
40 nucleotides in the blocker polynucleotide is at least as great as sequence T3 of the template polynucleotide sequence. Additional nucleotides may be bound to the ends of the hybridizable sequence B1, the number being dictated primarily by considerations of cost and practicality. Thus, 0-1000 or more nucleotides may be bound to the ends, or the blocker
45 polynucleotide could be cyclic, for example, by incorporating B1 into a

plasmid or phage DNA.

As a practical matter, when the blocker polynucleotide is a synthetic oligomer, it is desirable to use a short sequence, preferably less than 100, preferably less than 50, more preferably 10-40, nucleotides. It is important that the nucleotides in the hybridizable sequence B1, particularly those at the 5' end of B1 or those that bind near the 5' end of T2, strongly bind the opposing nucleotide in sequence T3. This can be achieved in a variety of ways. Preferably, the blocker will be GC rich, particularly in the region where it binds near to the 5' end of T2. For example, it is desirable to have present at least a five base sequence within the sequence B1 that contains at least four, and preferably five, G and C nucleotides. Alternatively, the entire B1 sequence or one or more nucleotides within B1 can be ribonucleotides or may be unnatural and may include substituted nucleotides or nucleotide mimics (such as a nucleotide with an intercalation group, e.g., ethidium, attached in a manner to permit intercalation when the nucleotide is incorporated with a double stranded sequence) or a polynucleotide containing a phosphate-deleted nucleotide. The important consideration with respect to the above is that the B1 sequence binds sufficiently selectively to sequence T3 that it does not interfere with binding of the primer or chain extension of the primer along the target polynucleotide sequence or along polynucleotide Q and serves to block or impede chain extension along at least that portion of T3 that is not shared in common with T2. Often T2 is contiguous with T3.

The 3' end of the blocker polynucleotide may be the same as the 3' end of B1 or may include additional nucleotides or substituents, for example, to prevent chain extension catalyzed by the polydeoxynucleotide polymerase.

Polynucleotide Q-- a single stranded polynucleotide, usually a synthetic oligonucleotide, either attached to the 5' end of a blocker polynucleotide or present as a separate reagent. Polynucleotide Q may be DNA or RNA, preferably DNA, and is comprised of two sequences of nucleotides. One of such sequences (S1) is 3' of the other of such sequences (S2) and is homologous with sequence T2. The 5' end of S1 is complementary to the 5' end of sequence B1 when the 5' end of T2 overlaps the 3' end of T3. The major criteria for choosing S1 is that the sequence should be reliable, that is, it should be sufficiently homologous to T2 that it will bind specifically to the 3' end of a DNA sequence composed of a sequence complementary to T2 to an extent at least sufficient to permit polynucleotide polymerase catalyzed extension of the DNA sequence along polynucleotide Q. The number of nucleotides in sequence S1 is equal to the number of nucleotides in the T2 sequence of the template polynucleotide sequence. When the T2 sequence is selected, for example 4-12 nucleotides, it is sometimes desirable to include multiple copies of S1 arranged in tandem in polynucleotide Q, usually 2-6 copies. The presence of multiple copies of S1 is not essential but can in some instances increase the yield

of single stranded polydeoxynucleotide with two defined sequences. Often S1 is from 5 - 50 nucleotides in length. Often a sequence comprising the 5' end of S1 is complementary to a sequence comprising the 5' end of B1. Alternatively these sequences are not complementary.

5 The second polynucleotide sequence of polynucleotide Q, designated S2, is a sequence of nucleotides that is 5' of S1 and may or may not be contiguous with S1. S2 is complementary to and thereby defines the first defined sequence that is to be introduced at the 3' end of the extended primer. S2 may contain a sequence that is substantially identical or
10 homologous to at least the 3' end of the polynucleotide primer and/or contain one or more sequences which, when bound to their complementary sequences, are specific binding sites for receptors such as repressors, restriction enzymes, and the like. S2 is at least 10 nucleotides, usually at least 15, preferably 20-50 deoxynucleotides, in length. In general, S2
15 will be about 10 to 2000 or more deoxynucleotides depending on the first defined sequence that is desired.

In the situation where polynucleotide Q is present as a separate reagent, it is sometimes desirable to prevent extension of the 3' end of polynucleotide Q along the extended polynucleotide primer. This may be
20 avoided by appending to the 3' end of S1 one or more nucleotides that are not complementary to the nucleotides in the target polynucleotide sequence contiguous with the 3' end of T2. Additionally or alternatively, the 3' end can be modified by phosphorylation, introduction of a dideoxynucleotide or a basic ribophosphate, attachment to a polymer or surface, or other
25 means for inhibiting chain extension. All of the above procedures for such modification are well known in the art. Furthermore, other procedures for such modifications will be suggested to those skilled in the art.

In the situation where polynucleotide Q is attached to the 5' end of the blocker polynucleotide, the sequence S1 may be contiguous to sequence
30 B1 or be separated by any convenient number of nucleotides, usually 0 - 100, preferably 0 - 40, more preferably 0 - 20.

Polynucleotide Q may contain additional spacer sequences or other sequences located between S1 and S2 or at the end of S2.

35 Non-contiguous--sequences are non-contiguous, there being at least one, usually at least 10, nucleotides between the two sequences.

Contiguous--sequences are considered to be contiguous when there are no nucleotides between the two sequences.

Copy -- a sequence that is identical to or homologous with a single
40 stranded polynucleotide sequence as differentiated from a sequence that is complementary to or hybridizable with the sequence of such single stranded polynucleotide. In single primer amplification described above in the background section, a complementary sequence of a single stranded polydeoxynucleotide sequence is produced initially as the result of the extension of a polynucleotide primer, and a sequence that is identical to
45 or homologous with the single stranded polydeoxynucleotide sequence is

subsequently obtained from further extension of the polynucleotide primer along the aforementioned complementary sequence.

Means for extending a primer -- a polynucleotide polymerase or a single stranded template polynucleotide having a sequence other than at its 3' end that can hybridize to at least the 3' end of the primer or both. Means for extending a primer also includes nucleoside triphosphates or analogs thereof capable of acting as substrates for the enzyme and other materials and conditions required for enzyme activity such as a divalent metal ion (usually magnesium), pH, ionic strength, organic solvent (such as formamide), and the like.

Member of a specific binding pair ("sbp member") -- one of two different molecules, having an area on the surface or in a cavity that specifically binds to and is thereby defined as complementary with a particular spatial and polar organization of the other molecule. The members of the specific binding pair are referred to as ligand and receptor (antiligand). These may be members of an immunological pair such as antigen-antibody, or may be operator-repressor, nuclease-nucleotide, biotin-avidin, hormones-hormone receptors, nucleic acid duplexes, IgG-protein A, DNA-DNA, DNA-RNA, and the like.

Ligand -- any compound for which a receptor naturally exists or can be prepared.

Receptor ("antiligand")--any compound or composition capable of recognizing a particular spatial and polar organization of a molecule, e.g., epitopic or determinant site. Illustrative receptors include naturally occurring receptors, e.g., thyroxine binding globulin, antibodies, enzymes, Fab fragments, lectins, nucleic acids, repressors, protection enzymes, protein A, complement component C1q, DNA binding proteins or ligands and the like.

Small organic molecule--a compound of molecular weight less than 1500, preferably 100 to 1000, more preferably 300 to 600 such as biotin, fluorescein, rhodamine and other dyes, tetracycline and other protein binding molecules, and haptens, etc. The small organic molecule can provide a means for attachment of a nucleotide sequence to a label or to a support.

Support or surface--a porous or non-porous water insoluble material. The support can be hydrophilic or capable of being rendered hydrophilic and includes inorganic powders such as silica, magnesium sulfate, and alumina; natural polymeric materials, particularly cellulosic materials and materials derived from cellulose, such as fiber containing papers, e.g., filter paper, chromatographic paper, etc.; synthetic or modified naturally occurring polymers, such as nitrocellulose, cellulose acetate, poly(vinyl chloride), polyacrylamide, cross linked dextran, agarose, polyacrylate, polyethylene, polypropylene, poly(4-methylbutene), polystyrene, polymethacrylate, poly(ethylene terephthalate), nylon, poly(vinyl butyrate), etc.; either used by themselves or in conjunction with other

materials; glass available as Bioglass, ceramics, metals, and the like. Natural or synthetic assemblies such as liposomes, phospholipid vesicles, and cells can also be employed.

5 Binding of sbp members to the support or surface may be accomplished by well-known techniques, commonly available in the literature. See, for example, "Immobilized Enzymes," Ichiro Chibata, Halsted Press, New York (1978) and Cuatrecasas, J. Biol. Chem., 245:3059 (1970). The surface can have any one of a number of shapes, such as strip, rod, particle, including bead, and the like.

10 Label or reporter group or reporter molecule--a member of the signal producing system. Usually the label or reporter group or molecule is conjugated to or becomes bound to a polynucleotide probe or a polynucleotide primer and is capable of being detected directly, or
15 indirecting by being bound through a specific binding reaction, to a detectable substance. Labels able to be detected indirectly include polynucleotides such as a polynucleotide primer or a specific polynucleotide sequence that can act as a ligand for a complementary polynucleotide or provide a template for amplification or ligation or act
20 as a ligand such as for a repressor protein; haptens; antibodies; receptors such as avidin; ligands such as biotin and the like. Labels able to be detected directly may be isotopic or nonisotopic, usually non-isotopic, and can be a catalyst, such as an enzyme, ribozyme, a substrate for a replicase such as QB replicase, promoter, dye, fluorescent molecule, chemiluminescer, coenzyme, enzyme substrate, radioactive group, a particle such as latex or
25 carbon particle, metal sol, crystallite, liposome, cell, etc., which may or may not be further labeled with a dye, catalyst or other detectible group, and the like. The label is a member of a signal producing system and can generate a detectable signal either alone or together with other members of the signal producing system. The label can be bound directly to a
30 nucleotide sequence or can become bound thereto by being bound to an sbp member complementary to an sbp member that is bound to a nucleotide sequence.

35 Signal Producing System--The signal producing system may have one or more components, at least one component being the label or reporter group. The signal producing system generates a signal that relates to the presence or amount of target polynucleotide sequence or a polynucleotide analyte in a sample. The signal producing system includes all of the reagents required to produce a measurable signal. When the label is not conjugated to a nucleotide sequence, the label is normally bound to an sbp member
40 complementary to an sbp member that is bound to or part of a nucleotide sequence. Other components of the signal producing system may be included in a developer solution and can include substrates, enhancers, activators, chemiluminescent compounds, cofactors, inhibitors, scavengers, metal ions, specific binding substances required for binding of signal generating
45 substances, and the like. Other components of the signal producing system

may be coenzymes, substances that react with enzymic products, other enzymes and catalysts, and the like. The signal producing system provides a signal detectable by external means, such as detection of electromagnetic radiation, desirably by visual examination. The
5 signal-producing system is described more fully in U.S. Patent Application Serial No. 07/555,323, filed July 19, 1990, the relevant disclosure of which is incorporated herein by reference, and in the corresponding EP-A-0469755.

10 Ancillary Materials--Various ancillary materials will frequently be employed in the method in accordance with the present invention. For example, buffers will normally be present in the medium, as well as stabilizers for the medium and the reaction components. Frequently, in addition to these additives, proteins may be included, such as albumins,
15 organic solvents such as formamide, quaternary ammonium salts, polycations such as dextran sulfate, surfactants, particularly non-ionic surfactants, binding enhancers, e.g., polyalkylene glycols, or the like.

One embodiment of the method is depicted schematically in Fig. 1. The 3' end of polynucleotide primer P comprising sequence S3 hybridizes with T1 of template polynucleotide A. A sequence B1 located at the 5' end
20 of a blocker polynucleotide B hybridizes with T3 of template polynucleotide A having sequences T1, T2 and T3. The 3' end of T3 lies within T2. T2 is homologous with sequence S1 of polynucleotide Q. Polynucleotide Q is attached to, i.e., is a continuing sequence of nucleotides in, the 5' end
25 of the blocker polynucleotide and contains sequences S1 and S2. The 5' end of S1 is complementary to the 5' end of B1. S2 in this example is homologous to S3. In the presence of deoxynucleoside triphosphates and DNA polymerase and under appropriate reaction conditions, the primer is extended along the template and along a portion of T2. Under the reaction
30 conditions at least the 3' end of the extended primer dissociates from the template at T2, hybridizes to S1 and extends along the polynucleotide Q to produce an extended primer D. The extended primer contains sequence S'2, which is complementary to S2 and, in this example, to S3. After
35 dissociation from its duplex the product, ss polydeoxynucleotide D, is obtained, which product contains a first defined sequence S'2 and a second defined sequence S3 that are hybridizable with each other.

A variation in the above embodiment is depicted in Fig 2. In this case in the presence of deoxynucleoside triphosphates and DNA polymerase and under appropriate reaction conditions, the primer is extended along the
40 template and along T2. Under the reaction conditions the polymerase partially displaces the 5' end of the blocker and the primer extends along the full length of T2. The 5' end of S1 is complementary to the 5' end of B1. The partially extended primer then switches strands, hybridizes to S1 and extends along the polynucleotide Q to produce an extended primer E
45 containing sequence S'2, which is complementary to S2 and, in this example, to S3. E now contains S3 and S'2, which are hybridizable with each other.

Another variation in the above embodiment is depicted schematically in Fig 3. In this case the polynucleotide Q is present as a separate reagent. The sequence B1 in the blocker and S1 in polynucleotide Q do not have complementary 5' ends. The sequence B1 in the blocker is complementary to T3 of template polynucleotide A, which has sequences T1, T2 and T3. The 3' end of T3 is contiguous with T2, both of which are 5' of and not contiguous with T1. In the presence of deoxynucleoside triphosphates and DNA polymerase and under appropriate reaction conditions, the primer hybridizes with T1 and is extended along the template and along at least a portion of T2. Under the reaction conditions the partially extended primer switches strands, hybridizes to S1 and extends along polynucleotide Q to produce an extended primer F containing sequence S'2, which is complementary to S2. When S2 is designed to be homologous with S3, S'2 is also complementary to S3. F now contains the defined sequences S3 and S'2, which are hybridizable with each other. In a variation of the above method the polynucleotide Q is the 5' portion of a larger polynucleotide comprising the blocker polynucleotide B. The extending primer extends along at least a portion of T2 prior to switching strands as shown in Fig. 1.

Another embodiment of the invention is depicted in Fig. 4. In this embodiment the sequence T2 in the template polynucleotide A is not contiguous with sequence T3. Also, the 5' ends of sequences S1 and B1 in polynucleotide Q are not complementary. Under suitable reaction conditions the primer is extended along the template and along at least a portion of T2 before it switches strands, hybridizes to S1 and extends along polynucleotide Q to produce the extended primer G. In a variation of the above approach, polynucleotide Q may be present as a separate reagent not attached to the blocker polynucleotide.

Another embodiment of the present invention is depicted in Fig. 5. In this embodiment T2 is homologous with S1 of the polynucleotide Q and the 5' end of T3 is 5' of the 5' end of T2 and the 3' end of T3 lies within T2. In this embodiment the entire S1 sequence is complementary to the 5' end of B1. The primer is extended along the template and along at least a portion of T2, which comprises the 3' end of T3. Under appropriate reaction conditions the extending primer switches strands, hybridizes to S1 and extends along polynucleotide Q to produce extended primer H. Polynucleotide Q can be present as a reagent separate from the blocker polynucleotide in an alternative embodiment of the invention.

Another embodiment of the invention is shown in Fig. 6. Polynucleotide Q is present as a separate reagent from the blocker polynucleotide B. The 5' end of sequence T3 is 5' of the 5' end of sequence T2. Sequence S1 is homologous to T2 and B1 is complementary to T3. Under appropriate reaction conditions the primer binds to T1 and is extended along at least a portion of T2. The extended primer then switches strands and hybridizes with S1 and extends along polynucleotide Q to

produce extended primer J.

The methods of the invention have application in any situation where a single stranded polynucleotide containing defined sequences is desired. Such a situation may be, for example, where it is desired to append flanking sequences to a polynucleotide to assist in insertion into a cloning vector, particularly where long strands are employed making it difficult to find suitable restriction enzymes. Introduction of defined sequences is also useful for mutagenesis studies, and for polymerase dependent amplifications methods such as PCR and single primer amplification.

The methods find particular use in single primer amplification, described above, wherein one or more copies of a target polynucleotide sequence, located between sequences T1 and T2 of a template polynucleotide, are formed. The use of the present method in single primer amplification is depicted in Fig. 7. Polydeoxynucleotide primer P has a sequence at its 3'-end (S3) that hybridizes with S'2 of extended primer produced as described above in Figs. 1-6. S'2 is complementary to S2 of the polynucleotide Q. Preferably, S3 is a sequence identical to S2. P can also comprise a label or reporter molecule W. P is hybridized with and extended along extended primer D (Fig. 1), E (Fig. 2), F (Fig. 3), G (Fig. 4), H (Fig. 5) or J (Fig.6), and is then dissociated from its duplex, to form extended primer K comprising sequences S3 and S'2, wherein S3 is complementary to S'2. Extended primer K is dissociated from its duplex and P hybridizes with S'2 and extends along the extended primer and D, E, F, G, H or J to yield K¹ and K, respectively. K¹ is complementary to K. The duplexes are dissociated and P is hybridized with and extended along K¹ and K to yield K¹ and K². Further repetition results in multiple copies of K¹ and K², which can be detected because of the presence of label W.

When the present method is applied to replicating a target polynucleotide sequence, one of the above described embodiments is utilized and the following steps are repeated at least once: (a) the polynucleotide primer is caused to hybridize with and extend along the extended primer to form a second duplex comprising extended primer and (b) the extended primer is dissociated from the second duplex. Normally, this process will be repeated at least three times. Preferably, the polynucleotide primer contains at least a fifteen deoxynucleotide sequence S3 capable of hybridizing with a sequence complementary to S2. Preferably, T1 and S2 each respectively contain from 10 to 100 nucleotides.

The method has application where the target polynucleotide sequence is DNA or RNA. In one aspect the polynucleotide primer is labeled with a reporter molecule. The reporter molecule can be, for example, a detectable group or a binder such as biotin or a nucleotide sequence other than the sequence that hybridizes with the sequence complementary to S2. The extended primer can be detected by means of a reporter molecule covalently

-20-

bonded to a probe. The probe will usually have a nucleotide sequence that is homologous or complementary to a portion of the target nucleotide sequence between T1 and T2.

5 Another embodiment of the invention concerns a method for detecting the presence of a polynucleotide analyte, comprising a template sequence, in a medium suspected of containing the polynucleotide analyte. The template sequence has three sequences T1, T2 and T3 wherein T1 is non-contiguous with and 3' of T2 and T3 and wherein the 5' end of T3 is 5' of the 5' end of T2. The medium is combined with a polynucleotide primer
10 whose 3' end is hybridizable with T1. A blocker polynucleotide with sequence B1, wherein B1 is hybridizable with T3 is also included. A polynucleotide Q having sequences S1 and S2 is attached to the 5' end of the blocker polynucleotide or is present as a separate reagent. S1 is 3' of S2 and is homologous to T2. S2 is homologous to at least the 3' end of
15 the primer polynucleotide. Deoxynucleoside triphosphates and one or more polydeoxynucleotide polymerases are employed. Conditions are chosen such that (A) the blocker becomes hybridized to the template sequence, (B) the primer becomes hybridized with and is extended along the template sequence and along at least a portion of T2 and thereafter along the polynucleotide
20 Q to form a duplex, (C) the extended primer is dissociated from the duplex, and (D) the primer hybridizes with and is extended along the extended primer to form a duplex comprising extended primer and steps (C) and (D) are repeated. Then, an examination is conducted for the presence of the extended primer, the presence thereof indicating the presence of the
25 polynucleotide analyte. Steps (C) and (D) are repeated a least 1 time, preferably, at least 10 times; usually it is preferable that the number of repetitions be less than 60. Generally, steps (C) and (D) are repeated a number of times sufficient to provide an accurate detection of the polynucleotide analyte. Where the polynucleotide analyte is RNA, it can
30 first be converted to DNA by means of a primer and reverse transcriptase, or the polydeoxynucleotide polymerase used in at least step B can be reverse transcriptase.

Appropriate reaction conditions are chosen for carrying out the method of forming the single stranded polydeoxynucleotide using a primer, and
35 amplification if desired. The following description sets forth such appropriate conditions, which are subject to modification by those skilled in the art depending on the specific reagents and other molecules chosen for any particular application.

Generally, an aqueous medium is employed. Other polar cosolvents may
40 also be employed in the medium, usually oxygenated organic solvents of from 1-6, more usually from 1-4, carbon atoms, including alcohols, ethers and the like. Usually, these cosolvents are present in less than about 70 weight percent, more usually, in less than about 30 weight percent.

The pH for the medium is usually in the range of about 5.5 to 10, more
45 usually, in the range of about 6.5 - 9.5, and, preferably, in the range of

about 7 - 9. The pH and temperature are chosen and varied, as the case may be, so as to cause, either simultaneously or wholly or partially sequentially, dissociation of any internally hybridized sequences, hybridization of the primer with the template polynucleotide and extended primer once the primer has been extended, extension of the primer along the template including some or all of sequence T2 but not past T2, dissociation of the partially extended primer from the template polynucleotide and hybridization of the partially extended primer to polynucleotide Q, and dissociation of the extended primer from its duplex. In some instances, a compromise will be made in optimizing the speed, efficiency, and specificity of these steps depending on whether it is desired to perform the above steps wholly or partially sequentially or simultaneously. Various buffers may be used to achieve the desired pH and maintain the pH during the determination. Illustrative buffers include borate, phosphate, carbonate, Tris, barbital and the like. The particular buffer employed is not critical to this invention but in individual methods one buffer may be preferred over another.

Moderate temperatures are normally employed for carrying out the method. As mentioned above, appropriate reaction conditions are chosen in order to achieve extension of the primer along the template onto sequence T2 while minimizing the extension of the extending primer into the region of the template 5' of T2 followed by strand switching of the extending primer from the template to polynucleotide Q. These reaction conditions are dependent on a number of considerations such as, for example, the salt concentration and the pH of the medium, the solvent composition of the medium used, the length of the target polynucleotide sequence and the length and nucleotide composition of sequences S1 and B1 and of the primer. The temperature for extension of the primer depends on the activity of the polymerase and can range from 5° to 90°, usually 25° to 80°, frequently 40° to 70°C. Strand switching may comprise a melting step where the extended primer is dissociated from the template polynucleotide and a hybridization step when it hybridizes to S1. The melting step temperature usually is 45° to 100°, more usually 70° to 98°C. The hybridization step temperature is usually 25° to 80°C, more usually 35° to 70°C. Strand switching can also occur without the melting step whereupon the temperature for strand switching is usually 35° to 90°C, preferably 45° to 80°C, frequently 50° to 75°C.

Normally, in conducting the method of the invention in conjunction with amplification, the medium is cycled between two or three temperatures. The temperatures for the present method in conjunction with amplification generally range from about 10° to 105°C, more usually from about 40° to 99°C, preferably 50° to 98°C. As with the method of the invention itself, the temperatures utilized can be varied depending on the salt concentration, pH, solvents used, length of the target polynucleotide sequence and of sequences S1 and S2 and nucleotide composition of the

target and/or template polynucleotide sequence and the primer. Relatively low temperatures of from about 30° to 65°C can be employed for the extension steps, while denaturation and hybridization can be carried out at a temperature of from about 50° to 105°C.

5 In some situations it is desirable to cause hybridization and extension to occur only after denaturation of the template polynucleotide is complete. This has the advantage of increasing the fidelity of replication and can be achieved by preheating the template to at least 80°C, preferably 90°-100°C, prior to combining it with the polymerase and/or nucleoside triphosphates that will usually also be preheated.

10 Where the present method is utilized in amplification of a polynucleotide sequence using one or more primers, the method is conducted for a time sufficient to achieve a desired number of copies of the extended primer or a sequence complementary thereto. This, in turn, depends on the purpose for which the amplification is conducted, such as, for example, an assay for a polynucleotide analyte. Generally, the time period for conducting the method is from about 20 seconds to 10 minutes per cycle and any number of cycles can be used from 1 to as high as 200 or more, usually 5 to 80, frequently 10-60. As a matter of convenience it is usually desirable to minimize the time period and the number of cycles. In general, the time period for a given degree of amplification can be shortened, for example, by selecting concentrations of nucleoside triphosphates sufficient to saturate the polynucleotide polymerase and by increasing the concentrations of polynucleotide polymerase and polynucleotide primer. Generally, the time period for conducting the method is from about 5 to 200 minutes. As a matter of convenience, it will usually be desirable to minimize the time period. The above conditions may also be chosen for forming a template polynucleotide sequence from a polynucleotide analyte as mentioned above.

25 30 The amount of the template polynucleotide can be as low as one or two molecules in a sample but generally varies from about 10^2 to 10^{14} , more usually from about 10^3 to 10^8 molecules in sample volumes that may be less than a microliter but will usually be 1-1000 μL , more usually 5-250 μL . The amount of the polynucleotide primer should be at least as great as the number of copies desired and is usually present in at least 10^{-9} M, preferably 10^{-7} M, and more preferably at least about 10^{-6} M. Preferably, the concentration of the polynucleotide primer is substantially in excess over, preferably at least 100 times greater than, the concentration of the single stranded polynucleotide.

35 40 The concentration of the deoxynucleoside triphosphates in the medium can vary widely; preferably, these reagents are present in an excess amount. The deoxynucleoside triphosphates are usually present in 10^{-6} to 10^{-2} M, preferably 10^{-5} to 10^{-3} M.

The concentration of the blocker polynucleotide is usually at least as

high as the template polynucleotide but preferably is at least 10^9M , normally 10^7 to 10^8M . The polynucleotide Q, when not attached to the blocker, is preferably at least 10^9M , normally at least 10^3M , most preferably at least 10^6M .

5 The concentration of the template-dependent polynucleotide polymerase is usually determined empirically. Preferably, a concentration is used that is sufficient such that further increase in the concentration does not decrease the time for the amplification by over 5-fold, preferably 2-fold. The primary limiting factor generally is the cost of the reagent.

10 The order of combining of the various reagents to form the combination may vary. Generally, the template polynucleotide is obtained from genetic material, DNA or RNA, from an organism or cell or from artificial constructs produced by molecular biological techniques. Generally, the template polynucleotide, the primer, the polynucleotide Q and the blocker
15 polynucleotide are combined with a pre-prepared combination of deoxynucleoside triphosphates, and template-dependent polydeoxynucleotide polymerase. However, simultaneous addition of all of the above, as well as other step-wise or sequential orders of addition, may be employed.

20 The concentration and order of addition of reagents and conditions for the method are governed generally by the desire to create a single stranded polydeoxynucleotide, having defined sequences, from a polynucleotide primer and a template polynucleotide. When the present method is used in conjunction with amplification of a polynucleotide sequence using one or more primers, one consideration is to maximize the number of copies of the
25 extended primer and the rate at which such copies are formed and the fidelity of replication. Generally, it is desirable to increase the number of copies of the extended primer by at least a factor of 10^2 , preferably a factor of 10^4 , more preferably 10^6 or more.

30 In carrying out the method of the invention as applied to the detection of a polynucleotide analyte, the considerations as to media, pH, temperature, and times are as described above. While the concentrations of the various reagents will generally be determined by the concentration range of interest of the polynucleotide analyte, the final concentration of each of the reagents will normally be determined empirically to optimize
35 the sensitivity of the assay over the range of interest. The concentration of the other reagents in an assay generally will be determined following the same principles as set forth above for the amplification method. The primary consideration is that a sufficient number of copies of extended primer be produced in relation to the polynucleotide analyte so that such
40 copies can be readily detected and provide an accurate determination of the polynucleotide analyte if present.

 The copies of extended primer can be detected in numerous ways. For example, in the present method, molecules of the polynucleotide primer can be labeled with a reporter molecule such as a ligand, a small organic

molecule, a polynucleotide sequence, a polypeptide, a support, an operator or the like. Examples of particular labels or reporter molecules and their detection can be found in U.S. Patent Application Serial No. 07/555,323 filed July 19, 1990, the relevant disclosure of which is incorporated
5 herein by reference, and in the corresponding EP-A-0469755. Other assay formats and detection formats are disclosed in U.S. Patent Applications Serial Nos. 07/299,282 and 07/399,795 filed January 19, 1989, and August 29, 1989, respectively, which have been incorporated herein by reference, and in corresponding EP-A-0379369. Any standard method for specifically
10 detecting nucleic acid sequences can be used.

One method for detecting nucleic acids is to employ nucleic acid probes. One method utilizing such probes is described in U.S. Patent No. 4,868,104, the disclosure of which is incorporated herein by reference.

Detection of the signal depends upon the nature of the signal
15 producing system utilized. If the label or reporter group is an enzyme, additional members of the signal producing system would include enzyme substrates and so forth. The product of the enzyme reaction is preferably a luminescent product, or a fluorescent or non-fluorescent dye, any of
20 which can be detected spectrophotometrically, or a product that can be detected by other spectrometric or electrometric means. If the label is a fluorescent molecule the medium can be irradiated and the fluorescence determined. Where the label is a radioactive group, the medium can be counted to determine the radioactive count.

Various techniques can be employed for preparing the polynucleotide
25 primer, blocker polynucleotide, the polynucleotide Q or other polynucleotide sequences utilized in the present invention. Such sequences can be obtained by biological synthesis or by chemical synthesis. For short sequences (up to about 100 nucleotides) chemical synthesis is frequently more economical as compared to biological synthesis. In
30 addition to economy, chemical synthesis provides a convenient way of incorporating low molecular weight compounds and/or modified nucleotides or bases during the synthesis step. Furthermore, chemical synthesis is very flexible in the choice of length and region of the target polynucleotide binding sequence. The polynucleotide primer, the blocker polynucleotide
35 the polynucleotide Q and other polynucleotides can be synthesized by standard methods such as those used in commercial automated nucleic acid synthesizers. Chemical synthesis of DNA or RNA on a suitably modified glass or resin can result in DNA or RNA covalently attached to the surface. This offers advantages in washing and sample handling. For longer
40 sequences standard replication methods employed in molecular biology can be used such as the use of M13 for single stranded DNA as described by J. Messing, Methods Enzymol(1983) 101: 20-78.

In addition to standard cloning techniques, in vitro enzymatic methods
45 may be used such as polymerase catalyzed reactions. For preparation of RNA, T7 RNA polymerase and a suitable DNA template can be used. For DNA,

polymerase chain reaction (PCR) and single primer amplification are convenient.

Other chemical methods of polynucleotide or oligonucleotide synthesis include phosphotriester and phosphodiester methods (Narang, *et al.*, *Meth. Enzymol* (1979) 68: 90) and synthesis on a support (Beaucage, *et al.*, *Tetrahedron* (1981) *Letters* 22: 1859-1862) as well as phosphoramidate technique, Caruthers, M. H., *et al.*, "Methods in Enzymology," Vol. 154, pp. 287-314 (1988), and others described in "Synthesis and Applications of DNA and RNA," S.A. Narang, editor, Academic Press, New York, 1987, and the references contained therein.

The design and preparation of the blocker polynucleotide is important in performing the methods of this invention. It is preferable that the B1 sequence be rich in guanine (G) and cytidine (C). Series of G's and C's relatively uninterrupted by A's and T's are particularly useful because their tight binding inhibits dissociation during primer extension and strand switching. Accordingly, the blocker polynucleotide should preferably contain at least 50% GC composition, preferably at least 60% GC composition. Other techniques to inhibit dissociation can be used such as providing the polynucleotide blocker with one or more covalently attached small molecules that can intercalate into or otherwise bind the double strand comprising B1 hybridized to T3. A large variety of small molecule binders are available such as ethidium, acridinium, and phenazinium ions, psoralin, daunomycin, mitomycin and the like. In the situation where a photoactive small molecule is used such as psoralin, additional enhancement of binding can be achieved by irradiation of the medium with light that is absorbed by the small molecule when the irradiation is carried out following hybridization of the blocker with the template. In each of these preparations the small molecule may be attached to any convenient atom of a base, e.g., the 8 position of G or A or the 4-amino group of C or the 5-methyl group of T, or the group may be attached to a ribose carbon or to a phosphate, for example, by alkylation of a phosphorothioate. Alternatively, the blocker may be synthesized with alternative atoms in place of the phosphate linkages. In particular, uncharged linkers can provide tighter binding to a complementary strand. Uncharged linkers that can be used are phosphonates, phosphites, amides, methylene dioxy groups and the like. The synthesis of these types of oligonucleotide analogs are known in the art.

A blocker polynucleotide containing at least one phosphorothioate diester can be prepared according to known techniques. Oligonucleotide synthesis can be carried out as described above up to the point where introduction of the phosphorothioate diester is desired. The phosphorothioate diester can be introduced in a number of ways such as, for example, oxidations utilizing a thiolating reagent such as a diacyldisulfide or tetraethyl thiuram disulfide, which are commercially available. The remaining nucleotides are then introduced. Other methods

of preparing phosphorothioate containing polynucleotides are described in WO9008838, WO8911486, U.S. Patent No. 4,910,300, EP318245, the relevant disclosures of which are incorporated herein by reference. Other methods of preparing a phosphorothioate containing polynucleotide are described by

5 (a) Yau, et al., Tetrahedron Lett. (1990)31(14): 1953-1956; (b) Brill, et al., ibid. (1989) 30(48):6621-6624; (c) Caruthers, et al., Nucleic Acids Symp. Ser. (1989)21: 119-120; (d) Caruthers, et al., Nucleosides Nucleotides (1988)8(5-6): 1011-1014; (e) Brill, et al., J. Am. Chem. Soc. (1989)111(6): 2321-2322.

10 As mentioned above, in some instances the 3'-end of a polynucleotide is modified to prevent reaction with template dependent DNA polymerase or to append a binding sequence. Usually, a DNA tail on the 3' end is all that is necessary. However, the 3'-end can be modified, for example, by

15 introducing an abasic ribophosphate or other unnatural group at the 3' end during solid phase synthesis or introduction of a dideoxynucleotide or a ribonucleotide followed by oxidation of the ribose with periodate followed by reductive amination of the resulting dialdehyde with borohydride and a bulky amine such as aminodextran. The details for carrying out the above modifications are well-known in the art and will not be repeated here.

20 Another embodiment of the present invention concerns a method for producing from a polynucleotide primer a single stranded polydeoxynucleotide that has two different defined sequences, for example, P1 and P'2. A template polynucleotide (template) is employed having three

25 sequences T1, T2 and T3. T1 is non-contiguous with and 3' of T2 and T3. The 3' end of T3 is contiguous with or lies without T2. The method utilizes a polynucleotide primer P1 whose 3' end is hybridizable with T1. A blocker polynucleotide is also employed and has sequence B1, wherein B1 is hybridizable with T3. Polynucleotide Q has sequences S1 and S2 and is either attached to the 5' end of the blocker polynucleotide or present as a

30 separate reagent. S1 is 3' of S2 and homologous to T2. S2 is a sequence complementary to a sequence different from P1, such as a sequence P'2 that is complementary to a second polydeoxynucleotide primer P2. The combination is subjected to conditions for extending the primer P1 along the template and along at least a portion of T2 and thereafter along

35 polynucleotide Q, dissociating partially extended primer P1 from its respective duplex, hybridizing partially extended primer P1 to polynucleotide Q. The extended primer M is dissociated from its duplex. A second single stranded polydeoxynucleotide N is formed by hybridizing a polydeoxynucleotide primer P2 to sequence P'2 of the extended primer M and

40 extending P2 along M and dissociating the second extended primer N from its duplex. The second extended primer N is characterized by having a sequence P'1 that is 3' of sequence P2 and is capable of hybridizing to primer P1. The resulting two single stranded polynucleotides M and N (fully extended primers P1 and P2) can then be amplified by the polymerase chain reaction,

45 which is described in, for example, U.S. Patent Nos. 5,008,182, 4,965,188,

4,800,159, 4,683,195 and 4,683,202, the relevant disclosures of which are incorporated hereing by reference. The conditions and reagents for accomplishing this aspect of the invention, including PCR amplification, are similar to those described above for the extension of primers in accordance with the present invention. Primer P2 hybridizes to P'2 of M and is extended along M and primer P1 hybridizes to P'1 of N and is extended along N. The extended primers are dissociated from their respective duplexes and are characterized in that each serves as a template for the other primer in a PCR amplification.

As a matter of convenience, predetermined amounts of reagents employed in the present invention can be provided in a kit in packaged combination. For use in accordance with the method of the present invention for forming a single stranded polynucleotide having defined sequences, the kit can comprise a polynucleotide primer, a blocker polynucleotide and a polynucleotide Q, which can be attached to the blocker polynucleotide or be unattached. These components can be provided as separate reagents or combined, preferably combined. In assaying for a polynucleotide analyte in a sample, a kit useful in the present method can comprise, in packaged combination with other reagents, (a) reagents for obtaining, from the polynucleotide analyte, a template polynucleotide sequence having sequences T1, T2 and T3 wherein T1 is 3' of T2 and T3 and T3 comprises of at a portion of T2, wherein such reagent may be, for example, a restriction enzyme, (b) at least one labeled or unlabeled primer having at its 3' end a sequence hybridizable with a first sequence T1 in a template polynucleotide sequence, (c) a blocker polynucleotide having sequence B1 hybridizable with sequence T3 in the template polynucleotide, and (d) a polynucleotide Q having sequences S1 and S2 wherein S1 is 3' of S2 and homologous to T2 in the template polynucleotide and wherein S2 is homologous to at least the 3' end portion of the primer, wherein polynucleotide Q is either attached to the 5' end of the blocker polynucleotide or present as a separate reagent.

The kit can further include a labeled or unlabeled polynucleotide probe capable of binding to the template polynucleotide sequence or to extended primer produced in the method of the invention. The kits above can further include in the packaged combination deoxynucleoside triphosphates (dNTPs) such as, e.g., deoxyadenosine triphosphate (dATP), deoxyguanosine triphosphate (dGTP), deoxycytidine triphosphate (dCTP) and deoxythymidine triphosphate (dTTP) or derivatives or analogs of the above. The kit can further include a polydeoxynucleotide polymerase and members of a signal producing system and also various buffered media, some of which may contain one or more of the above reagents.

In another embodiment of the invention the polynucleotide Q can have sequences S1 and S2 wherein S1 is 3' of S2 and homologous to T2 in the template polynucleotide and wherein S2 is homologous to at least the 3' end portion of a second primer. This latter kit finds use in, for example, PCR amplification.

The relative amounts of the various reagents in the kits can be varied widely to provide for concentrations of the reagents that substantially optimize the reactions that need to occur during the present method and to further substantially optimize the sensitivity of any assay, in which the present method is employed. Under appropriate circumstances one or more of the reagents in the kit can be provided as a dry powder, usually lyophilized, including excipients, which on dissolution will provide for a reagent solution having the appropriate concentrations for performing a method or assay in accordance with the present invention. Each reagent can be packaged in separate containers or some reagents can be combined in one container where cross-reactivity and shelf life permit.

EXAMPLES

The invention is demonstrated further by the following illustrative examples. Temperatures are in degrees centigrade (°C) and parts and percentages are by weight unless otherwise indicated.

EXAMPLE 1

Synthesis of Single Stranded Polynucleotide Having a Stem Loop Structure

Part A.

Materials:

Polynucleotide extender primer with and without 5'³²P label (Ext. Primer and 32P Ext. Primer, respectively):

Oligomer 1 (50-mer)

5'-AGC-CAT-GTT-TCG-GAA-CAC-CTA-TGC-TCG-CTT-CTG-GTG-CCG-GAA- ACC-AGG-CA- 3' (SEQ ID NO:1)

GC Blocker with and without 5'³²P label (GC Blocker and 32P-GC Blocker, respectively):

Oligomer 2 (40-mer)

5'-GCG-GGC-CTC-TTC-GCT-ATT-ACG-CCA-GCT-GGC-GAA-AGG-GGG-A-3' (SEQ ID NO:2)

AB Blocker with and without 5'³²P label (AB Blocker and 32P-AB Blocker, respectively):

Oligomer 3 (80-mer)

5'-AGC-CAT-GTT-TCG-GAA-CAC-CTA-TGC-TCC-CGC-ACC-GAT-CGC-CGC-GGG-CCT-CTT-CGC-TAT-TAC-GCC-AGC-TGG-CGA-AAG-GGG-GA-3' (SEQ ID NO:3)

Template polynucleotide:

Bam HI digested M13mp7 or Phage DNA (Bethesda Research Labs (BRL), Gaithersburg, MD), wherein M13mp7 was digested with Bam HI (BRL) according to protocol of manufacturer; M13mp19 RF from Pharmacia.

Other reagents:

10x Vent Buffer (100mM KCL, 200mM Tris-HCl, pH 8.8 at 25°C, 100mM
[NH₄]₂SO₄, 20mM MgSO₄, 1% Triton X-100); Vent Polymerase (New England
Biolabs, Beverly, MA); deoxyadenosine triphosphate (dATP), deoxyguanosine
5 triphosphate (dGTP), deoxycytidine triphosphate (dCTP) and deoxythymidine
triphosphate (dTTP) (referred to herein as dNTPs); H₂O.

Method:

10 Oligomers 1, 2 and 3 were synthesized by the phosphoramidite method
using a Biosearch DNA synthesizer (Millipore Corp., Bedford, MA) according
to the manufacturer's protocol and were purified by polyacrylamide gel
electrophoresis according to standard procedures. Concentrations were
determined by absorbance at 260 nm. Oligomers were labelled at the 5' end
with gamma-³²P-adenine triphosphate (ATP) by polynucleotide kinase.
15 Typically, 5 pmoles of the oligomers was incubated with 50 pmoles of gamma-
³²P-ATP and 5 units T4 polynucleotide kinase (Stratagene, San Diego, CA) for
1h at 37°C. Unreacted triphosphate was removed by passing the reaction
mixture over a Push column (Stratagene, Inc., sold under the trademark
NucTrap).

20 The reagents, except for the enzyme, were added (μl) in eppendorf tubes
marked Nos. 1-11 as shown in Table I.

Table I

Tube No.	1	2	3	4	5	6	7	8	9	10	11
H ₂ O	13	13	13	12	12	12	7	7	7	5	5
10X Vent Buffer	2	2	2	2	2	2	2	2	2	2	2
dNTP's (2 mM)	2	2	2	2	2	2	2	2	2	2	2
M13mp7 0.4 pmoles/5 ml	-	-	-	-	-	-	5	5	5	5	5
Ext. Primer 0.125pmoles /ml 32P-Ext. Primer Tracer	1 2	- -	- -	1 2	- -	- -	1 2	- -	- -	1 2	1 2
GC Blocker 0.125pmoles /ml 32P-GC Block Tracer	- -	1 2	- -	- -	1 2	- -	- -	1 2	- -	2 -	- -
AB Blocker 0.125pmoles /ml 32P-AB Block Tracer	- -	- -	1 2	- -	- -	1 2	- -	- -	1 2	- -	2 -
Vent polymerase 1 unit/ml	1	1	1	1	-	-	1	1	1	1	1

The above reaction mixtures were heated at 72°C for 2 minutes and then were allowed to cool to the room temperature. After adding the enzyme to the tubes according to Table I, the reaction mixtures were incubated at 65°C for 15 minutes. The reaction was stopped by adding 2 μ l, 0.5M ethylenediaminetetraacetic acid (EDTA) solution and 2 μ l of the reaction mixture from each tube was mixed with 4 μ l of formamide dye mixture 1 (90% formamide, 0.2% bromophenol blue (BB), 0.2% xylene cyanol (XC)) and heated at 90°C for 2 minutes and then cooled in ice.

The reaction products were evaluated by running 6 microlites of the formamide dye mixture on a 10% polyacrylamide, 8M urea gel, in 0.5 X Tris-

borate-EDTA (45 mM Tris-borate (made from Tris-HCl and boric acid)/2mM EDTA) (TBE) buffer and visualizing by exposure to X-ray film, a photocopy of which is shown in Fig. 8, which is discussed in more detail below. The yield of the products was determined by cutting out the bands and
5 quantifying counts for each product.

Results and Discussion:

The above reactions were carried out in order to demonstrate the method of the present invention to form a single stranded polynucleotide having two sequences that are non-contiguous and hybridizable with each other otherwise referred to as a stem loop structure. The method involved strand switching by an extending primer from a template polynucleotide to a polynucleotide Q in the presence of a blocker to form a polynucleotide with a stem loop structure. Polynucleotide Q, therefore, had a sequence S2 that
10 was homologous to the extending primer.

The above reactions were carried out separately with one of two blocker polynucleotides: a GC Blocker (Oligomer 2) that hybridized to the template M13mp7 at bases 6351 to 6391 and an AB Blocker (Oligomer 3) that had (1) a sequence of 40 bases or nucleotides at its 3'end [-5'-GCG-GGC-CTC-TTC-GCT-ATT-ACG-CCA-GCT-GGC-GAA-AGG-GGG-A-3' (SEQ ID NO:4)] that was identical to a sequence in the GC Blocker and that was capable of binding to M13mp7 at the same location, and (2) a polynucleotide Q [5'-AGC-CAT-GTT-TCG-GAA-CAC-CTA-TGC-TCC-CGC-ACC-GAT-CGC-C-3' (SEQ ID NO:5)] attached at its 5'end. Within Polynucleotide Q the 25 bases (underlined) at the 5'end were designated sequence S2, which was identical to 25 bases at the 5'end of the Ext. Primer (Oligomer 1). The remaining 15 bases were designated sequence S1. The 10 bases at the 3'end [-ACC-GAT-CGC-C- (SEQ ID NO:6)] of S1 were homologous to the 3'end of sequence T2, which was contiguous with the 3'end of sequence T3. The 5 bases [-CC-CGC- (SEQ ID NO:7)] at the 5'end of S1
25 were homologous to 5 bases at the 3'end of T3 and complementary to 5 bases at the 5'end of the AB Blocker.

Under the reaction conditions the Ext. Primer hybridized at bases 6441-6465 of the template and was extended along the template polynucleotide. As mentioned above, products obtained from the above reactions were visualized in the X-ray film of the polyacrylamide gel, a photocopy of which is shown in Fig. 8. The Lane Nos. shown in Fig. 8 correspond to the Tube Nos. of the above reactions with the exception of Tube Nos. 10-11, which correspond to Lane Nos. 11-12 and the sizes of marker DNA's are shown in Lane 10. In the absence of a blocker, Lane No.7, the product formed corresponded to the extension of the Ext. Primer to the end of the template (226 bases). In the presence of the GC Blocker (Lane No.11) approximately 40% of the products formed were about 100 bases in length (arising from the Ext. Primer stopping near the 5'end of the blocker), another 40% of the products formed were between 98-128 bases in length (arising from the extension of the Ext. Primer along a portion of
35
40
45

-32-

the template to which the blocker was hybridized) and the remainder of the products formed were approximately 225 bases in length (arising from the complete displacement of the blocker from the template and extension of the Ext. Primer through the entire length of the template). In the presence of the AB Blocker (Lane No.12) no products were formed that were 100 bases in length; there was a prominent band, not observed in any other reaction, that corresponded to a product that was 137 bases in length (accounting for about 63% of the total products formed in this reaction No.12). This product of reaction No.12 corresponded to the predicted polynucleotide having a stem loop structure formed in accordance with the present invention.

In order to determine that the above 137 base product was indeed formed in accordance with the method of the present invention, the product was subjected to single primer amplification conditions and sequenced as discussed below.

Part B.

Amplification of 137-base product.

Materials:

Single Primer 1:

Oligomer 4 (25-mer)

5'-AGC-CAT-GTT-TCG-GAA-CAC-CTA-TGC-T-3' (SEQ ID NO:8)

Single Primer 2:

Oligomer 5 (25-mer)

5'-TGT-TGT-TCC-GTT-AGT-TCG-TTT-TAT-T-3' (SEQ ID NO:9)

Extender Primer No. 376 sequence (56-mer)

5'-TGT-TGT-TCC-GTT-AGT-TCG-TTT-TAT-TGA-AAC-ACC-AGA-ACG-AGT-AGT-AAA-TTG-GGC-TT-3' (SEQ ID NO:10)

Oligomer 1 (Part A above).

Other reagents:

10x Vent Buffer; reaction products #10 and #11 from Part A; Vent Polymerase; dNTPs; H₂O.

Method:

Oligomers 4 and 5 were synthesized by the phosphoramidite method as described above and purified by polyacrylamide gel electrophoresis according to standard procedures. The reagents were added in the eppendorf tubes marked Nos. 1-8 as shown in Table II.

Table II

Tube No.	1	2	3	4	5	6	7	8
Reaction Mixture # From Part A. Above	11	11	11	11	10	10	10	See below
Reaction amount (μ l)	2	4	8	4	2	4	8	
H2O	83	81	77	82	83	81	77	
10x Vent Buffer (μ l)	10	10	10	10	10	10	10	
dNTP's (10mM) (μ l)	2	2	2	2	2	2	2	
Single Primer 1 Oligomer 4 (100 μ M) (μ l)	1	1	1	-	1	1	1	
Vent Polymerase (2 Units) (μ l)	2	2	2	2	2	2	2	

5 Tube Nos. 5-7 were negative controls and contained aliquots of reaction No.10 from Part A, above. These were not expected to have amplifiable DNA by single primer amplification. Tube No. 4 was a negative control as it
10 contained no primer. Tube No. 8 was a positive control and contained H2O (83 μ l), 10x Vent Buffer (10 μ l), Extender Primer No. 376, 10 μ M (1 μ l), Single Primer 2 (Oligomer 5) (1 μ l), (100 μ M), 10 mM dNTP's (2 μ l), M13mp19 template (1 μ l, containing approximately 6×10^6 molecules) and Vent DNA
15 polymerase (2 μ l). Prior to adding the enzyme the reaction mixture in tube No. 8 was heated to 95°C for 5 minutes and cooled at room temperature for 20 minutes. Thereafter, temperature cycling of 90°C for 30 seconds, 55°C for 60 seconds, and 72°C for 90 seconds was performed using a programmable thermal cycler (Twin Block EZ Cycler, Ericomp, Inc., San Diego, CA) for a total number of 60 cycles through the 3 temperatures. 10 μ l samples were
20 drawn from various reaction mixture at 0 cycles (before adding the Vent DNA polymerase), 30 cycles and 60 cycles and mixed with 2 μ l of 6X formamide dye mixture 2 (15% FICOLL 400, 0.25% BB, 0.25% XC dyes in H₂O). Accordingly, for example, Tube #1 was subjected to 0,30 and 60 cycles respectively, which corresponds to Lanes 1,2 and 3 in Fig. 9.

The reaction products were evaluated by running the total 12 microlitres of the above samples on a 1% agarose, 3% Nusieve (FMC BioProducts, Rockford, ME) agarose gel along side 5 μ l of Biomarker

(Bioventures, Inc., Murfreesboro, TN) in 1X TBE buffer (containing 90 mM Tris-borate pH 8.3, 4 mM EDTA) and visualizing by staining the gel with 0.5 µg/ml of ethidium bromide solution.

Results and Discussion:

5 As seen in the photocopy of the photograph of the above gel (Fig. 9), reaction No.1 (Lane Nos.1-3, with Lane 1 representing 0 cycles) yielded a product (designated as single primer amplification product) 130-140 bases in length after 30 (Lane No. 2) cycles and was present in considerable quantity after 60 (Lane No. 3) cycles. Reaction Nos. 4-7 corresponding to Lane Nos. 10-12, 14-16, 17-19, and 20-22 respectively did not yield any amplified product as seen in Lane Nos. 4-7, respectively, and reaction No. 8 corresponding to Lane Nos. 23-25 yielded an amplified product approximately 183 bases in length as expected and as seen in Lane No.8. Lane Nos. 13 and 26 are molecular weight markers. Lanes Nos. 4-6 (Tube #2) and 7-9 (Table #3) apparently resulted in SPA inhibition. Amplification of the product 130-140 bases in length by the single primer demonstrated that this product has an internal base paired structure or stem loop structure, which could only have been formed in accordance with the present invention.

15 The above single primer amplification product was next purified and sequenced as described below.

Part C:

Purification Step:

Method:

25 60 µl of the single primer amplification reaction mixture from above was mixed with 5 µl of 6X formamide dye mixture 2, described above, and 55 µl of this sample was loaded on and run on 3% NuSieve GTG agarose gel (FMC Bioproducts) in 40 mM Tris-acetate (made from Tris-HCl and acetic acid), 2 mM EDTA, pH 8.0 (TAE) buffer and visualized by staining with ethidium bromide. The appropriate band was excised and placed in two-1.5 ml eppendorf tubes and purified using Mermaid kit (Bio 101) according to the manufacturer's directions for the removal of low molecular weight or oligomer DNA from the agarose gel. The purified DNA was suspended in 14 µl H₂O.

35 Sequencing of Purified DNA: An Oligonucleotide Primer #10: 5'-CGC-TTC-TGG-TGC-CGG-AAA-CCA-GGC-A-3' (SEQ ID NO:11) was used together with a "Sequenase" kit (United States Biochemical Corp.) to sequence an aliquot of the purified product from above. Sequencing proved the identity of the product as an amplified DNA from the expected region of M13mp7 target polynucleotide.

EXAMPLE 2Synthesis of a Single Stranded Polynucleotide with Stem Loop Structure and its Amplification by Single Primer Amplification5 Part A:Materials:Polynucleotide primer:

Oligomer 6 (25-mer)

10 5'-CCC-GGT-TGA-TAA-TCA-GAA-AAG-CCC-C-3' (SEQ ID NO:12)

Blocker polynucleotide with Polynucleotide Q attached (underlined portion)(Composite Blocker):

Oligomer 7 (80-mer)

15 5' -CCC-GGT-TGA-TAA-TCA-GAA-AAG-CCC-CCC-CGC-ACC-GAT-CGC-CGC-GGG-CCT-CTT-CGC-TAT-TAC-GCC-AGC-TGG-CGA-AAG-GGG-GA-3' (SEQ ID NO:13)Master mix:

Prepared by combining 10x Vent buffer (100 microliter, containing 20 mM Tris.HCl, pH 8.8, 100 mM KCl, 100mM (NH₄)₂SO₄, 20 mM MgSO₄, and 1% Triton X-100), 20mM dNTP (10 microliter), 10⁻⁴M primer (10 microliter), 10⁻⁷M blocker (10 microliter) and H₂O (670 microliter) for a total of 800 microliter .

Template polynucleotide:

Linearized single stranded (s.s) M13mp7 and double stranded (d.s) M13mp19

25 METHOD:

Oligomers 6 and 7 were synthesized by the phosphoramidite method referred to above and purified on denaturing polyacrylamide gels according to standard procedures. Polynucleotide Q was the 40-5' terminal bases [5'-CCC-GGT-TGA-TAA-TCA-GAA-AAG-CCC-CCC-CGC-ACC-GAT-CGC-C- (SEQ ID NO:14)] of Oligomer 7 and was attached to the 5' end of the blocker polynucleotide, which was the 40-3' terminal bases [-GC-GGG-CCT-CTT-CGC-TAT-TAC-GCC-AGC-TGG-CGA-AAG-GGG-GA-3' (SEQ ID NO:15)] of Oligomer 7. Within Polynucleotide Q the 25-5' terminal bases (underlined) were designated as sequence S2, which was identical to polydeoxynucleotide primer Oligomer 6, and the remaining 15 bases at the 3' end of polynucleotide Q were designated as sequence S1 wherein the 5' end of S1 consists of 5 bases [-CC-CGC- (SEQ ID NO:16)] complementary to the 5 bases at the 5' end of the blocker polynucleotide and the 3' end of S1 consists of 10 bases [-ACC-GAT-CGC-C- (SEQ ID NO:17)] that were homologous to bases 6391-6400 on the template polynucleotide. The Composite Blocker was capable of hybridizing to M13mp7 at bases 6351-6390. Extension of the polynucleotide primer in accordance with the present invention generated an amplifiable polynucleotide sequence having an intramolecular base pair structure or stem loop structure. The polynucleotide primer hybridized to M13mp7 at bases 6806-6830.

-36-

The formation and amplification of such a stem loop molecule was carried out using single stranded M13mp7 and M13mp19 (double-stranded replicative form, 7250 base pairs from Bethesda Research Laboratories). Both were linearized by digestion with Bam HI according to manufacturer's directions to give template polynucleotide and M13mp19 was further denatured by heating it in boiling water for 10 minutes and immediately putting it in ice water before carrying out further steps. 80 microlitres of the master mix was added to eppendorf tubes marked Nos. 1-9 containing varying amounts of the template polynucleotides (Table III), and the above reaction mixtures were heated at 94°C for 4 minutes and cooled to room temperature for 10 minutes. This allowed the primer and the extended blocker to anneal to the template polynucleotide. Pfu polymerase (Stratagene, Inc.) was added (5 units). Temperature cycling of 90°C for 30 seconds, 55°C for 60 seconds and 72°C for 90 seconds was performed using a programmable thermal cycler (Ericomp, Inc.) for a total number of 60 cycles through the 3 temperatures. Products of the amplification were evaluated by running 15 microlitres of the reaction media along side appropriate controls on a 1.2% agarose gel, in 0.5x TBE buffer and visualizing by staining the gel with ethidium bromide; a photocopy of the photograph of the gel is shown in Fig. 10. Lane Nos. 1-9 correspond to Tube Nos. 1-9, Lane No. 10 is s.s M13mp7 as a positive control, Lane No. 11 is d.s M13mp19 as a positive control and Lane No. 12 is a negative control and Lane No. 13 represents molecular weight markers.

Table III

<u>Tube No.</u>	<u>Template Conc. (molecules)</u>
1	10 ² s.s M13mp7
2	10 ⁴ s.s M13mp7
3	10 ⁶ s.s M13mp7
4	10 ⁸ s.s M13mp7
5	10 ² d.s M13mp19
6	10 ⁴ d.s M13mp19
7	10 ⁶ d.s M13mp19
8	10 ⁸ d.s M13mp19
9	10 d.s M13mp19

Part B:

The above experiment was repeated with circular double stranded (d.s) M13mp19 as the template polynucleotide at different concentrations (see Table IV). The products of the amplification were evaluated by running 15 microliter of each of the reaction mixtures alongside appropriate controls on a 1.2 % agarose gel, in 0.5 X TBE buffer and visualizing by staining the gel with ethidium bromide (See Fig.11, discussed in more detail below, wherein Lane Nos. 1 and 9 correspond to molecular weight markers, Lane Nos. 2-5 correspond to Tube Nos. 1-4. Lane 6-8 had nothing loaded and Lane 7 is a negative control having no target.)

Table IV

	<u>Tube No.</u>	<u>Template Conc. (molecules)</u>
5	1	10 ² d.s M13mp19
	2	10 ³ "
	3	10 ⁴ "
	4	10 ⁵ "

10 RESULTS AND DISCUSSION:

The formation and amplification of a polynucleotide product 450 bases in length as indicated in Figs. 10 and 11 demonstrates that the polynucleotide primer (Oligomer 6) was extended along the template polynucleotide up to the Composite Blocker before it switched strands and was extended along polynucleotide Q to give extended primer having an internal base paired structure or stem loop structure. The latter molecule was then amplified by single primer amplification as described earlier.

20 Example 3

Effect of Temperature on Formation of a Single Stranded
Polynucleotide Having a Stem Loop Structure

25 Materials:

Polynucleotide primer with and without ³²P label (Primer and Tracer Primer, respectively):

Oligomer 8 (25-mer)

30 5'-CCC-GGT-TGA-TAA-TCA-GAA-AAG-CCC-C-3' (SEQ ID NO:18)

Extended Blocker (having Polynucleotide Q) with and without ³²P label:

Oligomer 9 (80-mer)

35 5'-CCC-GGT-TGA-TAA-TCA-GAA-AAG-CCC-CCC-CGC-ACC-GAT-CGC-CGC-GGG- CCT-
CTT-CGC-TAT-TAC-GCC-AGC-TGG-CGA-AAG-GGG-GA-3' (SEQ ID NO:19) Template

polynucleotide (Template):

Bam HI digested M13mp7 single stranded phage DNA

Others reagents;

10x Vent Buffer, Pfu Polymerase; dNTPs; H₂O.

40 Method:

Oligomers 8 and 9 were synthesized by the phosphoramidite method described above and purified by polyacrylamide gel electrophoresis according to standard procedures. The Extended Blocker (Oligomer 9), was capable of hybridizing to M13mp7 at bases 6351-6390. The polynucleotide primer (Oligomer 8) served to generate an amplifiable polynucleotide sequence having an intramolecular base pair, or stem loop, structure and

hybridized to M13mp7 at bases 6806-6830. All the reagents except for the enzyme were added (μ l) in eppendorf tubes marked Nos. 1-6 as shown in Table V.

Table V

Tube No.	1	2	3	4	5	6
H ₂ O (μ l)	10	9	9	9	9	9
10X Vent Buffer (μ l)	2	2	2	2	2	2
2 mM d NTP's (μ l)	2	2	2	2	2	2
0.25 pmoles/3 μ l M13mp7 Template (μ l)	3	3	3	3	3	3
0.25 pmoles/ μ l Oligomer 9 Extended Blocker (μ l)	1	1	1	1	1	1
0.25 pmoles/ μ l Oligomer 8 Primer (μ l)	1	1	1	1	1	1
32P Tracer Oligomer 8 Primer (μ l)	2	2	2	2	2	2
2.5 Units/ μ l Pfu DNA Polymerase	1	1	1	1	1	1
Temp. ($^{\circ}$ C) of Extension Reaction	65	55	60	65	70	75

The above reaction mixtures were heated at 94 $^{\circ}$ C for 4 minutes and then allowed to cool to the room temperature. After adding the enzyme to the tubes according to Table V the reaction mixtures were incubated at indicated temperatures for 15 minutes. 2 μ l of the reaction mixture from each tube was mixed with 4 μ l of formamide dye mixture 2, described above, and heated at 94 $^{\circ}$ C for 4 minutes and then cooled in ice.

The reaction products were evaluated by running 6 microlites of the aliquots plus formamide dye mixture on a 6% acrylamide, 8M urea gel, in 0.5 X TBE buffer and visualizing by exposure to X-ray film, a photocopy of which is shown in Fig. 12, which is discussed in more detail below.

Results and Discussion:

In order to determine the effect of temperature on strand switching resulting in the formation of a polynucleotide with a stem loop structure, the above reaction was conducted. The reaction was done with the extended blocker. The Extended Blocker had 40 bases at the 3' end capable of hybridizing to the template. The 40 bases at the 5' end of the Extended Blocker comprised polynucleotide Q. Within polynucleotide Q the 25 bases

at its 5' end were the same as the primer.

The products obtained from the above reactions at different temperatures with the Extended Blocker are shown in the photocopy of the X-ray film of the gel (Fig 12). Lanes 2-7 correspond to reaction nos. 1-6 and Lane 1 indicates the sizes of marker DNA's. In the absence of a blocker reaction no. 1 (Lane 2) the product corresponded to the extension of the primer to the end of the template (566 bases). However, as the temperature increased (Lanes 3-6) there was an increase in the amount of the expected strand switched product of approximately 480 bases in length (arrows on Fig. 12). At 75°C, when polymerase was efficiently displacing blocker oligomer 8 (Lane 7), the amount of this expected product decreased.

EXAMPLE 4

Synthesis of a Single Stranded Polynucleotide with Stem Loop Structure Upon E. coli Genomic DNA and its Amplification by Single Primer Amplification

Part A:

Materials:

Polynucleotide Primer:

Oligomer 10 (25-mer)

5'-CAA-AAC-AGC-GGA-AGA-GCG-TGA-AAT-C-3' (SEQ ID NO:20)

Blocker Polynucleotide with Polynucleotide Q (underlined) Attached (Composite Blocker):

Oligomer 11 (80-mer)

5'-CAA-AAC-AGC-GGA-AGA-GCG-TGA-AAT-CGG-CCC-TGA-CAG-TGT-GGG-GCC-GCG-GTA-CGC-TGA-TCA-AAG-ATC-CGT-GCA-ACA-AAT-GT-3' (SEQ ID NO:21)

Standard Reaction Mix:

(100 microliters) Prepared by combining 9 microliters of 10x Pfu buffer #2 (containing 200mM TRIS-Cl, pH 8.8 (25°C), 100mM KCl, 60mM (NH₄)₂SO₄, 15mM MgCl₂, 1% TRITON X-100), 1 microliter of 20mM dNTP's, 0.5 microliter of 2x10⁻⁴M Oligomer 10, 0.5 microliter of 2x10⁻⁵M Oligomer 11, 2 microliters of 2.5 units/microliter Pfu DNA Polymerase (Stratagene, Inc.), E. coli genomic DNA target in 10 microliters 1X Pfu buffer #2, and water to make a final volume of 100 microliters.

Method:

15 reactions of 100 microliters volume each were tested for amplification yields. Two components of the reactions were varied. The E. coli genomic DNA target concentrations were, in groups of five reactions, 10⁶, 10⁴, 10², 10 and 0 targets, respectively, per test tube.

This group of five reactions was made in quadruplicate, and the resulting four sets of five reactions were each treated with a different temperature cycling protocol. All reactions were assembled at room

temperature, and then cycled once at 96°C for 5 mins., 65°C for 10 mins. and 72°C for 4 mins. Then, the first set of five reactions was cycled 60 times at 93°C 1 min., 63°C 1 min. and 72°C 1.5 mins. In the next three sets of reactions the lowest annealing temperature was raised 2°C for each set, e.g., 65°C for the second set of five reactions, 67°C for the third, and 69°C for the fourth. The extension time at these temperatures remained 1 minute. The purpose of these experiments was to study optimization protocols for SPA on bacterial genomic targets.

Fig. 13 is a photocopy of an agarose gel electrophoresis of aliquots of nineteen single primer amplification reactions described above. Lanes 1-5 are single primer amplification reactions with 10⁶, 10⁴, 10², 10 and 0 targets where the lowest annealing temperature in the 60 cycles was 63°C. Lanes 6-10, 11-15 and 16-19 represent the remaining three sets of five reactions in the same series of target number but with annealing temperatures of 65°C, 67°C and 69°C, respectively. The 0 target reaction of the fourth set is not shown. A size marker is in Lane 20.

Results and Discussion:

The expected size of the single primer amplified DNA product is indicated by an arrow in Fig. 13. This designation was verified by restriction enzyme digestion of the product and hybridization to appropriate probes (data not shown). Fig. 13 shows that, as the lowest annealing temperature rose above 65°C, the sensitivity of this series of single primer amplification reactions began to decrease. The best temperature regimen for this target, with the above primer and blocker combination and under the above buffer conditions, appears to be 93°C 1 min., 65°C 1 min. and 72°C 1.5 mins. Amplified DNA representing amplification from 10 targets of DNA is clearly visible in Lane 9. All negative target controls on this gel, Lanes 5, 10, and 15, show no amplified target, as expected. Lane 20 is a size marker (50-1000bp from Research Genetics).

EXAMPLE 5

Synthesis of a Single Stranded Polynucleotide with Stem Loop Structure Upon Mycobacterium tuberculosis Genomic DNA in the presence of Human Genomic DNA and its Amplification by Single Primer Amplification

Materials:

Polynucleotide Primer

Oligomer 12 (25-mer)

5' -TAG-CCC-TTG-TCG-AAC-CGC-ATA-CCC-T-3' (Seq. ID No:22)

Blocker Polynucleotide with Polynucleotide Q (underlined)

Attached (Composite Blocker):

Oligomer 13 (70-mer)

5' -TAG-CCC-TTG-TCG-AAC-CGC-ATA-CCC-TGT-GTG-TCC-ATA-TGG-ACA -CAC-CAT-CGT-TGG-TGA-TCG-TGG-GGG-CAC-C-3' (Seq. ID No. 23)

Standard Reaction Mix:

(100 microliters) Prepared by combining 10 microliters of 10X Pfu buffer (containing 100 mM TRIS-HCl, pH 8.8 (25 °C), 500 mM KCl, 15 mM MgCl₂, 1% TRITON X-100, 75 mM Dithiothreitol, 2 microliters of 10mM dNTP' s, 1 microliter of 100 uM oligomer 12, 1 microliter of 5 uM oligomer 13, 2 microliters of 2.5 units/microliter cloned Pfu polymerase (Stratagene, Inc.), varying amounts of M. tuberculosis genomic DNA and varying amounts of total human placental genomic DNA (SIGMA), and water to make a total volume of 100 microliters.

Method:

15 separate amplification reactions were prepared in which there were three sets of five which had approximately 10⁴, 10³, 10², 10 and 0 molecules of M. tuberculosis genomic DNA in each of the five tubes, respectively. The first set of five had no added human genomic DNA, the second set of five had 10 ng. of human genomic DNA and the third set of five had 100 ng. of human genomic DNA added. The reactions were assembled at room temperature (approximately 22 °C) then denatured at 95 °C for 3 minutes, and then temperature cycled using 45 cycles consisting of the three temperature regimen: 94 °C for 1 minute, 66 °C for 1 minute , and 72 °C for 1 minute.

Figure 14 is a picture of an ethidium bromide stained 1.2% agarose gel onto which has been run 12 microliters of the 100 microliters from the above 15 temperature cycled reactions. The expected size amplicon (450 base pairs) is detectable in all reactions containing M. tuberculosis genomic target DNA, except for the reaction containing approximately 10 targets in the presence of 100 ng. of human genomic DNA (lane 15 of Figure 14).

In order to suppress mispriming and thereby achieve more specific and sensitive amplification of the M. tuberculosis target DNA, reactions similar to those above were assembled at 72 °C before temperature cycling was begun. Specifically, 50 microliters consisting of 400 uM dNTP' s, 2 uM primer oligomer 12, 100 nM blocker oligomer 14, and water all in 1X buffer was heated to 72 °C. Another 50 microliter volume consisting of 5 units of Pfu DNA polymerase, 1 microgram of human placental genomic DNA, varying concentrations of M. tuberculosis genomic DNA and water all in 1X buffer was heated to 72°C. These two volumes were mixed rapidly in order to form a complete reaction of 100 microliters which maintains a temperature above 66 °C. The reaction was denatured for 3 minutes at 95 °C, then temperature cycled through a three temperature regimen of 94 °C for 1 minute, 66 °C for 1 minute and 72 °C for 1 minute.

12 microliter aliquots of the above reactions were examined on agarose gels as above, except that aliquots were withdrawn at 45, 50, 55 and 60 temperature cycles (Figure 15). Unlike in the first set of reactions above, these set of reactions which incorporate starting the reactions at a

high temperature and which contain 1 microgram of human genomic DNA do indeed allow detection of approximately 10 molecules of M. tuberculosis genomic DNA targets (see lanes 5, 10, 15 and 20 of Figure 15). The expected amplicon band of 450 base pairs is indisputable in the 10 target, 60 cycle lane. The bands seen in the gel of the negative controls (0 targets) are nonspecific amplifications (lanes 6, 11, 16 and 21). This interpretation is supported by restriction digestion mapping of the amplified DNA's (Figure 16). The expected restriction fragments from the 450 bp amplicons are present in digests of all amplifications except the 0 target controls.

A comparison of Single Primer Amplification to the Polymerase Chain Reaction (PCR), performed using the same target genomic DNA of M. tuberculosis, showed equal sensitivity, but the PCR gave an intensely staining band often referred to as a "primer-dimer" which was not present in the SPA reactions.

Results and Discussion:

It is desirable that a DNA amplification technique be capable of amplifying small numbers of target molecules despite the presence of vast excess of non-target DNA molecules. Clinical samples containing the DNA target of interest will often contain large amounts of non-target DNA, and the amplification must be specific enough to detect only target and amplify little or none of non-target DNA. The SPA primer and blocker used in this example were directed to a region of genomic DNA known to be generic for various species of mycobacteria (1). This example demonstrates the ability of Single Primer Amplification to amplify small numbers Mycobacterial genomic DNA in the presence of vast excess human DNA.

(1.) Journal of Clinical Microbiology (1993), Vol. 31, No. 2, pp. 175-178. "Rapid Identification of Mycobacteria to the Species Level by Polymerase Chain Reaction and Restriction Enzyme Analysis."

Figure 14

Non "hot-start" SPA reactions with added human genomic DNA.

Lanes 1 and 17 contain a DNA size ladder standard of 123 base pair (bp) (BRL, Inc.). Lanes 2-6, 7-11 and 12-16 are aliquots of reactions containing 10^4 , 10^3 , 10^2 , 10 and 0 molecules of M. tuberculosis (M. tb.) genomic DNA target present in the SPA reactions described in the text. The group of reactions 2-6 have no added human genomic DNA. Reactions 7-11 contain 10 nanograms of human genomic DNA and reactions 12-16 contain 100 nanograms of genomic DNA. The expected 450 base pair amplicon band of SPA from lane 15 is lost in this series of reactions, presumably due to loss of sensitivity when competing human genomic DNA is present in this non "hot-start" reaction of only 10 targets of M. tb. genomic DNA.

Figure 15

"Hot-start" SPA reactions with 1 microgram of human genomic DNA added.

Lanes 1 and 22 contain the 123 bp standard DNA ladder. Lanes 2-6, 7-

11, 12-16, and 17-21 represent aliquots from reactions containing 10^4 , 10^3 , 10^2 , 10 and 0 targets of M. tb. genomic DNA. Lanes 2-6 represent the reactions after 45 temperature cycles; lanes 7-11 after 50 cycles; lanes 12-16 after 55 temperature cycles and lanes 17-21 after 60 temperature cycles. All five reactions contained 1 microgram of human placental genomic DNA. Even with as few as 10 target M. tb genomes, the original photograph demonstrates detection of the expected 450 bp amplicon in as few as 45 cycles (lane 5). No 450 bp bands are detected in this agarose gel in the 0 target negative controls (lanes 6, 11, 16 and 21).

Figure 16

Restriction enzyme analysis of selected SPA and PCR reaction amplicon products.

Lanes 1 and 12 are DNA size markers: lane 1 is an Msp 1 digest of pBR322 and lane 12 is a 123 bp ladder (BRL, Inc). All products on this gel come from SPA (Fig. 15) or PCR reactions. Lanes 2 and 3 represent before and after BstE II restriction digests of the SPA amplicon from 100 targets of M. tb. DNA, after 60 cycles of amplification. The expected restriction fragments of 245, 125 and 80 base pairs are detectable in lane 3, proving the identity of the 450 bp amplicon from lane 2. Lanes 4 and 5 represent digestion of the 450 bp amplicon from a SPA using 10 targets. Lane 5 again shows the faint but detectable expected BstE II restriction pattern, as well as nonspecific amplification products which are not substrates for BstE II. Lanes 6 and 7 are a similar study where no M. tb. targets were present, and there is no detectable 450 bp amplicon nor restriction products from this amplicon. Lanes 8 and 9 represent the 440 bp amplicon from a PCR reaction using 100 targets after 60 cycles. BstE II restriction enzyme treatment yield the expected 235, 125, and 80 bp fragments. Lanes 10 and 11 are the same as 8 and 9 except the PCR started with 10 targets. The expected amplicon and restriction fragment are present.

SEQUENCE LISTING

(1) GENERAL INFORMATION:

(i) APPLICANT:

- (A) NAME: Syntex (U.S.A.) Inc
- (B) STREET: 3401 Hillview Avenue
- (C) CITY: Palo Alto
- (D) STATE: CA
- (E) COUNTRY: USA
- (F) POSTAL CODE (ZIP): CA 94303

(ii) TITLE OF INVENTION: Method for Introducing Defined Sequences at the 3' End of Polynucleotides

(iii) NUMBER OF SEQUENCES: 23

(iv) COMPUTER READABLE FORM:

- (A) MEDIUM TYPE: Floppy disk
- (B) COMPUTER: IBM PC compatible
- (C) OPERATING SYSTEM: PC-DOS/MS-DOS
- (D) SOFTWARE: PatentIn Release #1.0, Version #1.25 (EPO)

(2) INFORMATION FOR SEQ ID NO:1:

(i) SEQUENCE CHARACTERISTICS:

- (A) LENGTH: 50 base pairs
- (B) TYPE: nucleic acid
- (C) STRANDEDNESS: single
- (D) TOPOLOGY: linear

(ii) MOLECULE TYPE: DNA (genomic)

(iii) HYPOTHETICAL: NO

(iv) ANTI-SENSE: NO

(v) FRAGMENT TYPE: internal

(vi) ORIGINAL SOURCE:

- (A) ORGANISM: synthetic

(xi) SEQUENCE DESCRIPTION: SEQ ID NO:1:

AGCCATGTTT CGGAACACCT ATGCTCGCTT CTGGTGCCGG AAACCAGGCA

50

(2) INFORMATION FOR SEQ ID NO:2:

(i) SEQUENCE CHARACTERISTICS:

- (A) LENGTH: 40 base pairs
- (B) TYPE: nucleic acid
- (C) STRANDEDNESS: single
- (D) TOPOLOGY: linear

(ii) MOLECULE TYPE: DNA (genomic)

(iii) HYPOTHETICAL: NO

(iv) ANTI-SENSE: NO

(v) FRAGMENT TYPE: internal

(vi) ORIGINAL SOURCE:

- (A) ORGANISM: synthetic

(xi) SEQUENCE DESCRIPTION: SEQ ID NO:2:

GCGGGCCTCT TCGCTATTAC GCCAGCTGGC GAAAGGGGGA

40

(2) INFORMATION FOR SEQ ID NO:3:

(i) SEQUENCE CHARACTERISTICS:

- (A) LENGTH: 80 base pairs
- (B) TYPE: nucleic acid
- (C) STRANDEDNESS: single
- (D) TOPOLOGY: linear

(ii) MOLECULE TYPE: DNA (genomic)

(iii) HYPOTHETICAL: NO

(iv) ANTI-SENSE: NO

(v) FRAGMENT TYPE: internal

(vi) ORIGINAL SOURCE:

-46-

(A) ORGANISM: synthetic

(xi) SEQUENCE DESCRIPTION: SEQ ID NO:3:

AGCCATGTTT CGGAACACCT ATGCTCCCGC ACCGATCGCC GCGGGCCTCT TCGCTATTAC 60
GCCAGCTGGC GAAAGGGGGA 80

(2) INFORMATION FOR SEQ ID NO:4:

(i) SEQUENCE CHARACTERISTICS:

- (A) LENGTH: 40 base pairs
- (B) TYPE: nucleic acid
- (C) STRANDEDNESS: single
- (D) TOPOLOGY: linear

(ii) MOLECULE TYPE: DNA (genomic)

(iii) HYPOTHETICAL: NO

(iv) ANTI-SENSE: NO

(v) FRAGMENT TYPE: internal

(vi) ORIGINAL SOURCE:

- (A) ORGANISM: synthetic

(xi) SEQUENCE DESCRIPTION: SEQ ID NO:4:

GCGGGCCTCT TCGCTATTAC GCCAGCTGGC GAAAGGGGGA 40

(2) INFORMATION FOR SEQ ID NO:5:

(i) SEQUENCE CHARACTERISTICS:

- (A) LENGTH: 40 base pairs
- (B) TYPE: nucleic acid
- (C) STRANDEDNESS: single
- (D) TOPOLOGY: linear

(ii) MOLECULE TYPE: DNA (genomic)

(iii) HYPOTHETICAL: NO

-47-

(iv) ANTI-SENSE: NO

(v) FRAGMENT TYPE: internal

(vi) ORIGINAL SOURCE:

(A) ORGANISM: synthetic

(xi) SEQUENCE DESCRIPTION: SEQ ID NO:5:

AGCCATGTTT CGGAACACCT ATGCTCCCGC ACCGATCGCC

40

(2) INFORMATION FOR SEQ ID NO:6:

(i) SEQUENCE CHARACTERISTICS:

(A) LENGTH: 10 base pairs

(B) TYPE: nucleic acid

(C) STRANDEDNESS: single

(D) TOPOLOGY: linear

(ii) MOLECULE TYPE: DNA (genomic)

(iii) HYPOTHETICAL: NO

(iv) ANTI-SENSE: NO

(v) FRAGMENT TYPE: internal

(vi) ORIGINAL SOURCE:

(A) ORGANISM: synthetic

(xi) SEQUENCE DESCRIPTION: SEQ ID NO:6:

ACCGATCGCC

10

(2) INFORMATION FOR SEQ ID NO:7:

(i) SEQUENCE CHARACTERISTICS:

(A) LENGTH: 5 base pairs

(B) TYPE: nucleic acid

(C) STRANDEDNESS: single

(D) TOPOLOGY: linear

(ii) MOLECULE TYPE: DNA (genomic)

-48-

(iii) HYPOTHETICAL: NO

(iv) ANTI-SENSE: NO

(v) FRAGMENT TYPE: internal

(vi) ORIGINAL SOURCE:

(A) ORGANISM: synthetic

(xi) SEQUENCE DESCRIPTION: SEQ ID NO:7:

CCCGC

5

(2) INFORMATION FOR SEQ ID NO:8:

(i) SEQUENCE CHARACTERISTICS:

(A) LENGTH: 25 base pairs

(B) TYPE: nucleic acid

(C) STRANDEDNESS: single

(D) TOPOLOGY: linear

(ii) MOLECULE TYPE: DNA (genomic)

(iii) HYPOTHETICAL: NO

(iv) ANTI-SENSE: NO

(v) FRAGMENT TYPE: internal

(vi) ORIGINAL SOURCE:

(A) ORGANISM: synthetic

(xi) SEQUENCE DESCRIPTION: SEQ ID NO:8:

AGCCATGTTT CGGAACACCT ATGCT

25

(2) INFORMATION FOR SEQ ID NO:9:

(i) SEQUENCE CHARACTERISTICS:

(A) LENGTH: 25 base pairs

(B) TYPE: nucleic acid

(C) STRANDEDNESS: single

(D) TOPOLOGY: linear

-49-

(ii) MOLECULE TYPE: DNA (genomic)

(iii) HYPOTHETICAL: NO

(iv) ANTI-SENSE: NO

(v) FRAGMENT TYPE: internal

(vi) ORIGINAL SOURCE:

(A) ORGANISM: synthetic

(xi) SEQUENCE DESCRIPTION: SEQ ID NO:9:

TGTTGTTCCG TTAGTTCGTT TTATT

25

(2) INFORMATION FOR SEQ ID NO:10:

(i) SEQUENCE CHARACTERISTICS:

(A) LENGTH: 56 base pairs

(B) TYPE: nucleic acid

(C) STRANDEDNESS: single

(D) TOPOLOGY: linear

(ii) MOLECULE TYPE: DNA (genomic)

(iii) HYPOTHETICAL: NO

(iv) ANTI-SENSE: NO

(v) FRAGMENT TYPE: internal

(vi) ORIGINAL SOURCE:

(A) ORGANISM: synthetic

(xi) SEQUENCE DESCRIPTION: SEQ ID NO:10:

TGTTGTTCCG TTAGTTCGTT TTATTGAAAC ACCAGAACGA GTAGTAAATT GGGCTT

56

(2) INFORMATION FOR SEQ ID NO:11:

(i) SEQUENCE CHARACTERISTICS:

(A) LENGTH: 25 base pairs

(B) TYPE: nucleic acid

-50-

- (C) STRANDEDNESS: single
- (D) TOPOLOGY: linear

(ii) MOLECULE TYPE: DNA (genomic)

(iii) HYPOTHETICAL: NO

(iv) ANTI-SENSE: NO

(v) FRAGMENT TYPE: internal

(vi) ORIGINAL SOURCE:

- (A) ORGANISM: synthetic

(xi) SEQUENCE DESCRIPTION: SEQ ID NO:11:

CGCTTCTGGT GCCGAAACC AGGCA

25

(2) INFORMATION FOR SEQ ID NO:12:

(i) SEQUENCE CHARACTERISTICS:

- (A) LENGTH: 25 base pairs
- (B) TYPE: nucleic acid
- (C) STRANDEDNESS: single
- (D) TOPOLOGY: linear

(ii) MOLECULE TYPE: DNA (genomic)

(iii) HYPOTHETICAL: NO

(iv) ANTI-SENSE: NO

(v) FRAGMENT TYPE: internal

(vi) ORIGINAL SOURCE:

- (A) ORGANISM: synthetic

(xi) SEQUENCE DESCRIPTION: SEQ ID NO:12:

CCCGTTGAT AATCAGAAA GCCCC

25

(2) INFORMATION FOR SEQ ID NO:13:

(i) SEQUENCE CHARACTERISTICS:

- (A) LENGTH: 80 base pairs
- (B) TYPE: nucleic acid
- (C) STRANDEDNESS: single
- (D) TOPOLOGY: linear

(ii) MOLECULE TYPE: DNA (genomic)

(iii) HYPOTHETICAL: NO

(iv) ANTI-SENSE: NO

(v) FRAGMENT TYPE: internal

(vi) ORIGINAL SOURCE:

- (A) ORGANISM: synthetic

(xi) SEQUENCE DESCRIPTION: SEQ ID NO:13:

CCCGTTGAT AATCAGAAAA GCCCCCCCGC ACCGATCGCC GCGGGCCTCT TCGCTATTAC 60

GCCAGCTGGC GAAAGGGGGA 80

(2) INFORMATION FOR SEQ ID NO:14:

(i) SEQUENCE CHARACTERISTICS:

- (A) LENGTH: 40 base pairs
- (B) TYPE: nucleic acid
- (C) STRANDEDNESS: single
- (D) TOPOLOGY: linear

(ii) MOLECULE TYPE: DNA (genomic)

(iii) HYPOTHETICAL: NO

(iv) ANTI-SENSE: NO

(v) FRAGMENT TYPE: internal

(vi) ORIGINAL SOURCE:

- (A) ORGANISM: synthetic

(xi) SEQUENCE DESCRIPTION: SEQ ID NO:14:

CCCGGTTGAT AATCAGAAAA GCCCCCCCGC ACCGATCGCC

40

(2) INFORMATION FOR SEQ ID NO:15:

(i) SEQUENCE CHARACTERISTICS:

- (A) LENGTH: 40 base pairs
- (B) TYPE: nucleic acid
- (C) STRANDEDNESS: single
- (D) TOPOLOGY: linear

(ii) MOLECULE TYPE: DNA (genomic)

(iii) HYPOTHETICAL: NO

(iv) ANTI-SENSE: NO

(v) FRAGMENT TYPE: internal

(vi) ORIGINAL SOURCE:

- (A) ORGANISM: synthetic

(xi) SEQUENCE DESCRIPTION: SEQ ID NO:15:

GCGGGCCTCT TCGCTATTAC GCCAGCTGGC GAAAGGGGGA

40

(2) INFORMATION FOR SEQ ID NO:16:

(i) SEQUENCE CHARACTERISTICS:

- (A) LENGTH: 5 base pairs
- (B) TYPE: nucleic acid
- (C) STRANDEDNESS: single
- (D) TOPOLOGY: linear

(ii) MOLECULE TYPE: DNA (genomic)

(iii) HYPOTHETICAL: NO

(iv) ANTI-SENSE: NO

(v) FRAGMENT TYPE: internal

(vi) ORIGINAL SOURCE:

- (A) ORGANISM: synthetic

-53-

(xi) SEQUENCE DESCRIPTION: SEQ ID NO:16:

CCCGC

5

(2) INFORMATION FOR SEQ ID NO:17:

(i) SEQUENCE CHARACTERISTICS:

(A) LENGTH: 10 base pairs

(B) TYPE: nucleic acid

(C) STRANDEDNESS: single

(D) TOPOLOGY: linear

(ii) MOLECULE TYPE: DNA (genomic)

(iii) HYPOTHETICAL: NO

(iv) ANTI-SENSE: NO

(v) FRAGMENT TYPE: internal

(vi) ORIGINAL SOURCE:

(A) ORGANISM: synthetic

(xi) SEQUENCE DESCRIPTION: SEQ ID NO:17:

ACCGATCGCC

10

(2) INFORMATION FOR SEQ ID NO:18:

(i) SEQUENCE CHARACTERISTICS:

(A) LENGTH: 25 base pairs

(B) TYPE: nucleic acid

(C) STRANDEDNESS: single

(D) TOPOLOGY: linear

(ii) MOLECULE TYPE: DNA (genomic)

(iii) HYPOTHETICAL: NO

(iv) ANTI-SENSE: NO

(v) FRAGMENT TYPE: internal

(vi) ORIGINAL SOURCE:

-54-

(A) ORGANISM: synthetic

(xi) SEQUENCE DESCRIPTION: SEQ ID NO:18:

CCCGGTTGAT AATCAGAAAA GCCCC

25

(2) INFORMATION FOR SEQ ID NO:19:

(i) SEQUENCE CHARACTERISTICS:

(A) LENGTH: 80 base pairs

(B) TYPE: nucleic acid

(C) STRANDEDNESS: single

(D) TOPOLOGY: linear

(ii) MOLECULE TYPE: DNA (genomic)

(iii) HYPOTHETICAL: NO

(iv) ANTI-SENSE: NO

(v) FRAGMENT TYPE: internal

(vi) ORIGINAL SOURCE:

(A) ORGANISM: synthetic

(xi) SEQUENCE DESCRIPTION: SEQ ID NO:19:

CCCGGTTGAT AATCAGAAAA GCCCCCCCGC ACCGATCGCC GCGGGCCTCT TCGCTATTAC

60

GCCAGCTGGC GAAAGGGGGA

80

(2) INFORMATION FOR SEQ ID NO:20:

(i) SEQUENCE CHARACTERISTICS:

(A) LENGTH: 25 base pairs

(B) TYPE: nucleic acid

(C) STRANDEDNESS: single

(D) TOPOLOGY: linear

(ii) MOLECULE TYPE: DNA (genomic)

(iii) HYPOTHETICAL: NO

-55-

(iv) ANTI-SENSE: NO

(v) FRAGMENT TYPE: internal

(vi) ORIGINAL SOURCE:

(A) ORGANISM: synthetic

(xi) SEQUENCE DESCRIPTION: SEQ ID NO:20:

CAAAACAGCG GAAGAGCGTG AAATC

25

(2) INFORMATION FOR SEQ ID NO:21:

(i) SEQUENCE CHARACTERISTICS:

(A) LENGTH: 80 base pairs

(B) TYPE: nucleic acid

(C) STRANDEDNESS: single

(D) TOPOLOGY: linear

(ii) MOLECULE TYPE: DNA (genomic)

(iii) HYPOTHETICAL: NO

(iv) ANTI-SENSE: NO

(v) FRAGMENT TYPE: internal

(vi) ORIGINAL SOURCE:

(A) ORGANISM: synthetic

(xi) SEQUENCE DESCRIPTION: SEQ ID NO:21:

CAAAACAGCG GAAGAGCGTG AAATCGGCC TGACAGTGTG GGGCCCGGT ACGCTGATCA

60

AAGATCCGTG CAACAAATGT

80

(2) INFORMATION FOR SEQ ID NO:22:

(i) SEQUENCE CHARACTERISTICS:

(A) LENGTH: 25 base pairs

(B) TYPE: nucleic acid

(C) STRANDEDNESS: single

(D) TOPOLOGY: linear

(ii) MOLECULE TYPE: DNA (genomic)

(iii) HYPOTHETICAL: NO

(iii) ANTI-SENSE: NO

(v) FRAGMENT TYPE: internal

(xi) SEQUENCE DESCRIPTION: SEQ ID NO:22:

TAGCCCTTGT CGAACCGCAT ACCCT

25

(2) INFORMATION FOR SEQ ID NO:23:

(i) SEQUENCE CHARACTERISTICS:

(A) LENGTH: 70 base pairs

(B) TYPE: nucleic acid

(C) STRANDEDNESS: single

(D) TOPOLOGY: linear

(ii) MOLECULE TYPE: DNA (genomic)

(iii) HYPOTHETICAL: NO

(iii) ANTI-SENSE: NO

(v) FRAGMENT TYPE: internal

(xi) SEQUENCE DESCRIPTION: SEQ ID NO:23:

TAGCCCTTGT CGAACCGCAT ACCCTGTGTG TCCATATGGA CACACCATCG TTGGTGATCG

60

TGGGGGCACC

70

-57-

WHAT IS CLAIMED IS:

1. A method for producing a single stranded polynucleotide having two or more defined nucleic acid sequences, said method comprising the steps of:

(a) hybridizing a sequence B1 of a blocker polynucleotide to a complementary sequence T3 within a template polynucleotide ("template"), said template being comprised of a sequence T1 and a sequence T2, wherein the 5' end of said T3 is 5' of the 5' end of said T2 and said T2 and T3 are 5' to and non-contiguous with said sequence T1,

(b) hybridizing the 3' end of a polynucleotide primer comprising a second defined sequence to said T1 wherein step (b) is performed prior to, after, or simultaneously with step (a), and

(c) extending said primer along said template and along at least a portion of said T2 and thereafter along a polynucleotide Q having sequences S1 and S2 wherein S1 is 3' of S2 and homologous with said T2 to give an extended primer having a first defined nucleic acid sequence at its 3' end that is complementary to S2, wherein polynucleotide Q is either attached to the 5' end of said blocker polynucleotide or is present as a separate reagent.

2. A method according to claim 1 for producing from a primer polynucleotide a single stranded polydeoxynucleotide having two segments that are non-contiguous and complementary with each other, said method comprising the steps of:

(a) providing in combination (a) a template polynucleotide having three sequences T1, T2 and T3 wherein T1 is non-contiguous and 3' of said T2 and T3 and the 3' end of said T3 is contiguous with or lies within said T2, (b) a primer polynucleotide whose 3' end is hybridizable with said T1 (c) a blocker polynucleotide with sequence B1, said B1 being hybridizable with said T3, and (d) a polynucleotide Q having sequence S1 and sequence S2 wherein said Q is either attached to the 5' end of said blocker polynucleotide or present as a separate reagent and wherein S1 is 3' of said S2 and homologous to said T2 and wherein said S2 is a sequence that is homologous to at least the 3' end of said primer polynucleotide, and

(b) subjecting said combination to conditions for extending said primer along said template polynucleotide and along at least a portion of said T2, and thereafter along said polynucleotide Q.

3. A method of producing at least one copy of a target polynucleotide sequence, said method comprising the step of: providing in combination, either concomitantly or wholly or partially sequentially, (1) a template polynucleotide having three sequences T1, T2 and T3 wherein T1 is non-contiguous and 3' of said T2 and T3 and wherein the 3' end of said T3 is contiguous with or lies within said T2 and wherein

-58-

5 said target polynucleotide sequence is located between said T1 and T3, (2) a primer polynucleotide whose 3' end is hybridizable with said T1, (3) a blocker polynucleotide with sequence B1, said B1 being hybridizable with said T3, (4) a polynucleotide Q having sequences S1 and S2 wherein said Q is either attached to the 5' end of said blocker polynucleotide or present as a separate reagent and wherein S1 is 3' of S2 and homologous to said T2 and wherein said S2 is a sequence that is homologous to at least the 3' end of said primer polynucleotide, (5) DNA polymerase and (6) deoxynucleoside triphosphates under conditions wherein: (A) said blocker becomes hybridized to said template polynucleotide, (B) said primer becomes hybridized with and extended along said target polynucleotide sequence of said template polynucleotide and along at least a portion of said T2, and thereafter along said polynucleotide Q to form a duplex, (C) said extended primer is dissociated from the said duplex, and (D) said primer hybridizes with and is extended along said extended primer to form a duplex comprising extended primer containing a copy of said target sequence.

20 4. The method of Claim 3 wherein at least a five base sequence of said B1 is comprised of at least 80% G and C nucleotides.

5. The method of Claim 3 or 4 wherein said T2 is contiguous with said T3.

25 6. The method of Claim 3, 4 or 5 wherein said polynucleotide Q is attached to the 5' end of said blocker polynucleotide.

7. A method according to claim 3 of forming multiple copies of a target polynucleotide sequence, said method comprising the steps of:

30 (a) providing in combination, either concomitantly or wholly or partially sequentially, (1) a template polynucleotide having three sequences T1, T2 and T3 wherein T1 is non-contiguous and 3' of said T2 and T3 and wherein the 3' end of said T3 is contiguous with or lies within said T2 and wherein said target polynucleotide sequence is located between said T1 and T3, (2) a primer polynucleotide whose 3' end is hybridizable with said T1, (3) a blocker polynucleotide with sequence B1, said B1 being hybridizable with said T3, (4) a polynucleotide Q having sequences S1 and S2 wherein said Q is either attached to the 5' end of said blocker polynucleotide or present as a separate reagent and wherein S1 is 3' of S2 and homologous to said T2 and wherein said S2 is a sequence that is homologous to at least the 3' end of said primer polynucleotide, (5) DNA polymerase and (6) deoxynucleoside triphosphates under conditions wherein: (A) said blocker becomes hybridized to said template polynucleotide, (B) said primer becomes hybridized with and extended along said target polynucleotide sequence of said template polynucleotide and along at least a portion of said T2 and thereafter along said polynucleotide Q to form a

45

duplex, (C) said extended primer is dissociated from the said duplex, and (D) said primer hybridizes with and is extended along said extended primer to form a duplex comprising extended primer containing a copy of said target sequence and

5 (b) repeating steps (C) and (D).

8. A method for detecting the presence of a polynucleotide analyte, said analyte comprising a template sequence having three sequences T1, T2 and T3 wherein T1 is non-contiguous with and 3' of said T2 and T3 and the 5' end of said T3 is 5' of the 5' end of said T2, in a medium suspected of containing said analyte said method comprising the steps of:

10 (a) combining said medium with (1) a primer polynucleotide whose 3' end is hybridizable with said T1, (2) a blocker polynucleotide with sequence B1, said B1 being hybridizable with said T3, (3) a polynucleotide Q having sequences S1 and S2 wherein Q is attached to the 5' end of said blocker polynucleotide or is present as a separate reagent and wherein S1 is 3' of said S2 and is homologous to said T2 and wherein said S2 is homologous to at least the 3' end of said primer polynucleotide, (4) DNA polymerase and (5) deoxynucleoside triphosphates under conditions wherein:

15 (A) said blocker becomes hybridized to said template, (B) said primer becomes hybridized with and extended along said template and along at least a portion of said T2 and thereafter along said polynucleotide Q to form a duplex, (C) the extended primer is dissociated from said duplex, and (D) said primer hybridizes with and is extended along said extended primer to form a duplex comprising extended primer and steps (C) and (D) are repeated, and

20 (b) examining for the presence of said extended primer.

9. A kit comprising in packaged combination:

30 (a) a primer polynucleotide having a sequence at its 3' end hybridizable with a first sequence T1 in a target polynucleotide

(b) a blocker polynucleotide having a sequence B1, said B1 being hybridizable with a sequence T3 in said target polynucleotide wherein said T3 is 3' of said T1 and the 5' end of said T3 is 5' of the 5' end of a sequence T2, and

35 (c) a polynucleotide Q having sequences S1 and S2 wherein S1 is 3' of said S2 and homologous to said T2 in said template polynucleotide and wherein said S2 is a sequence that is homologous to at least the 3' end portion of said primer.

40 10. A method according to claim 1 for producing from a polynucleotide primer a single stranded polydeoxynucleotide having two different defined sequences P1 and P'2, said method comprising the steps of:

45 (a) providing in combination (1) a template polynucleotide (template)

-60-

having three sequences T1, T2 and T3 wherein T1 is non-contiguous with and 3' of said T2 and T3 and the 3' end of said T3 is contiguous with or lies within said T2, (2) a polynucleotide primer (primer) P1 whose 3' end is hybridizable with said T1, (3) a blocker polynucleotide with sequence B1, said B1 being hybridizable with said T3, and (4) polynucleotide Q having a sequence S1 and a sequence S2 wherein said Q is either attached to the 5' end of said blocker polynucleotide or present as a separate reagent and wherein said S1 is 3' of said S2 and homologous to said T2 and wherein said S2 is complementary to said P'2, and

10 (b) subjecting said combination to conditions for extending said primer P1 along the template and along at least a portion of said T2 and thereafter along said polynucleotide Q.

11. A composition comprising a single strand of DNA comprised of a sequence T3 and a sequence T2 wherein the 3' end of said T3 is contiguous with the 5' end of T2, said single strand being complexed to a blocker DNA sequence comprised of a sequence B1 complementary to said T3 and a sequence S1 which is 5' of B1 and homologous to said T2.

20 12. A kit comprising in packaged combination:

(a) a primer polynucleotide having a sequence at its 3' end hybridizable with a first sequence T1 in a target polynucleotide

25 (b) a blocker polynucleotide having a sequence B1, said B1 being hybridizable with a sequence T3 in said target polynucleotide wherein said T3 is 3' of said T1 and the 5' end of said T3 is 5' of the 5' end of a sequence T2, and

30 (c) a polynucleotide Q having sequences S1 and S2 wherein S1 is 3' of said S2 and homologous to said T2 in said template polynucleotide and wherein said S2 is a sequence that is homologous to at least the 3' end portion of a second polynucleotide primer.

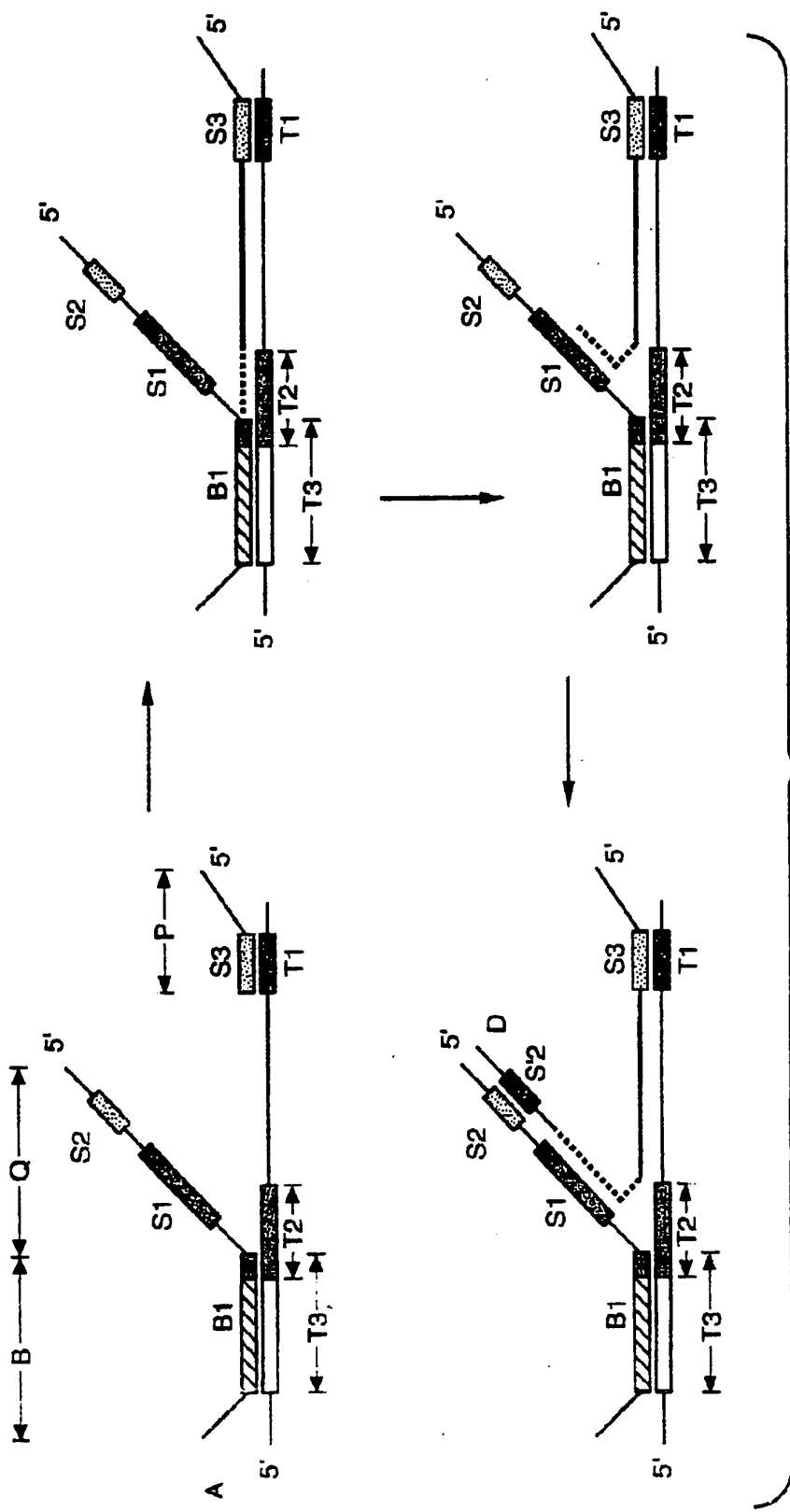

FIG.-1

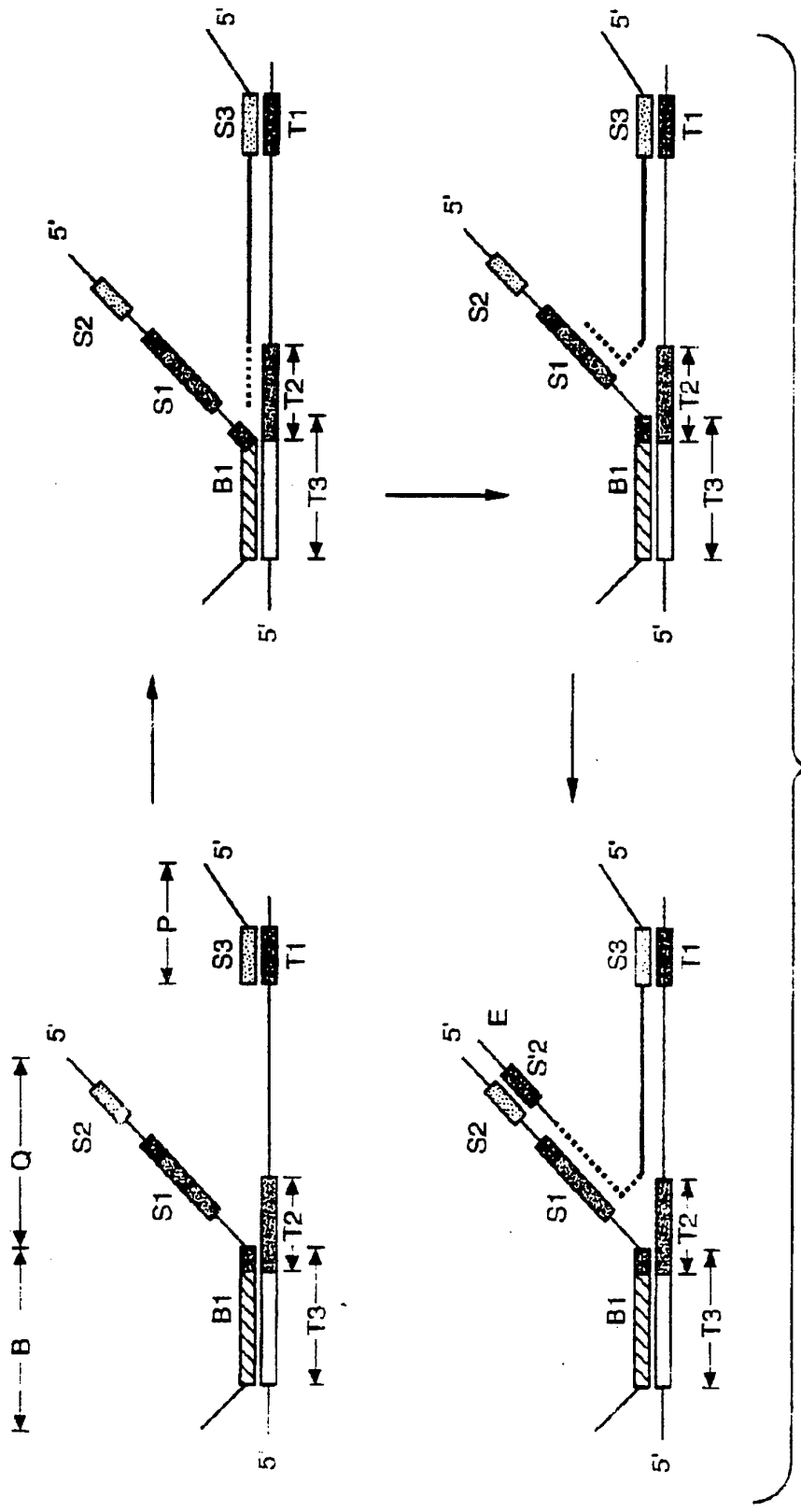

FIG. 2

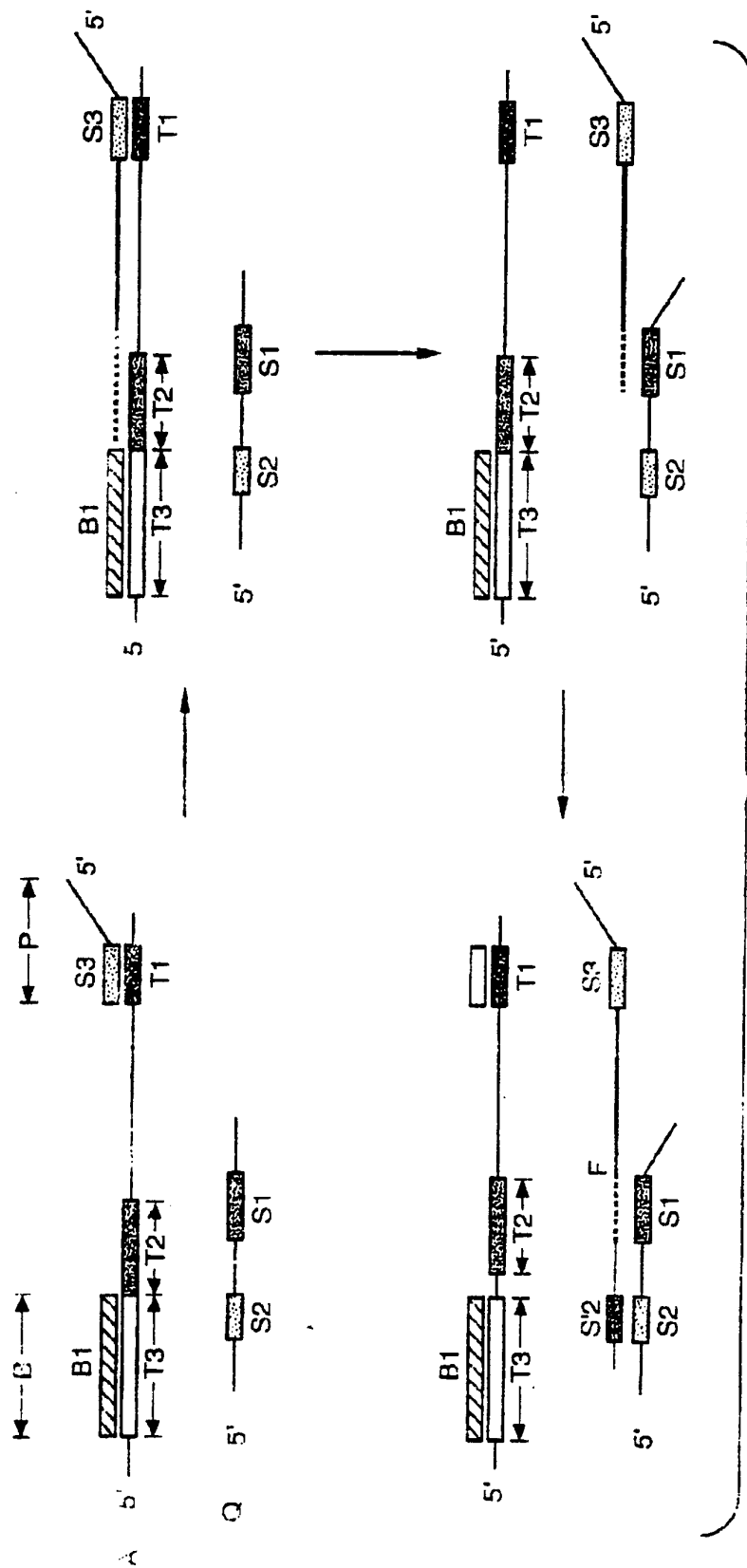

FIG._3

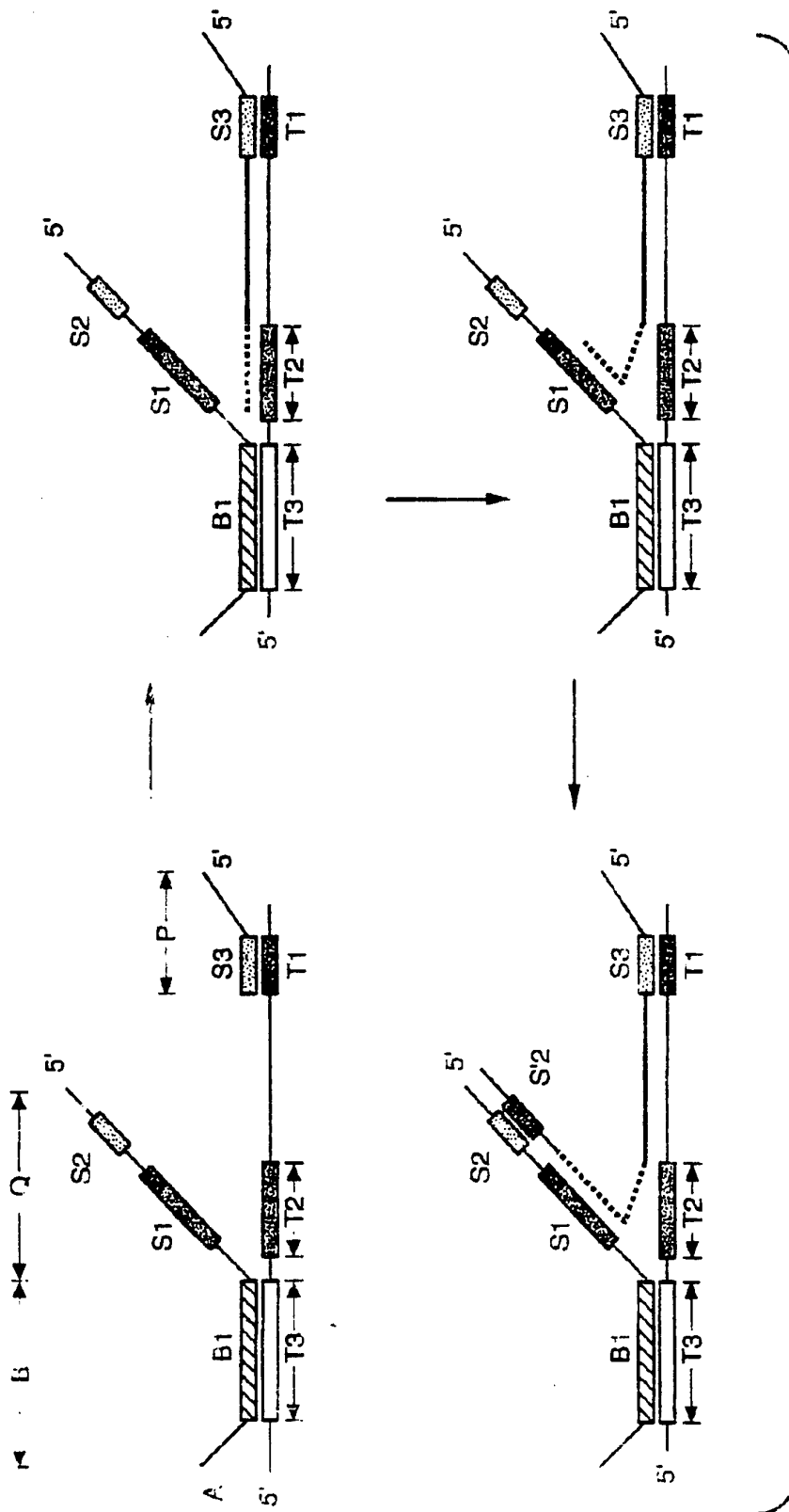

FIG. 4

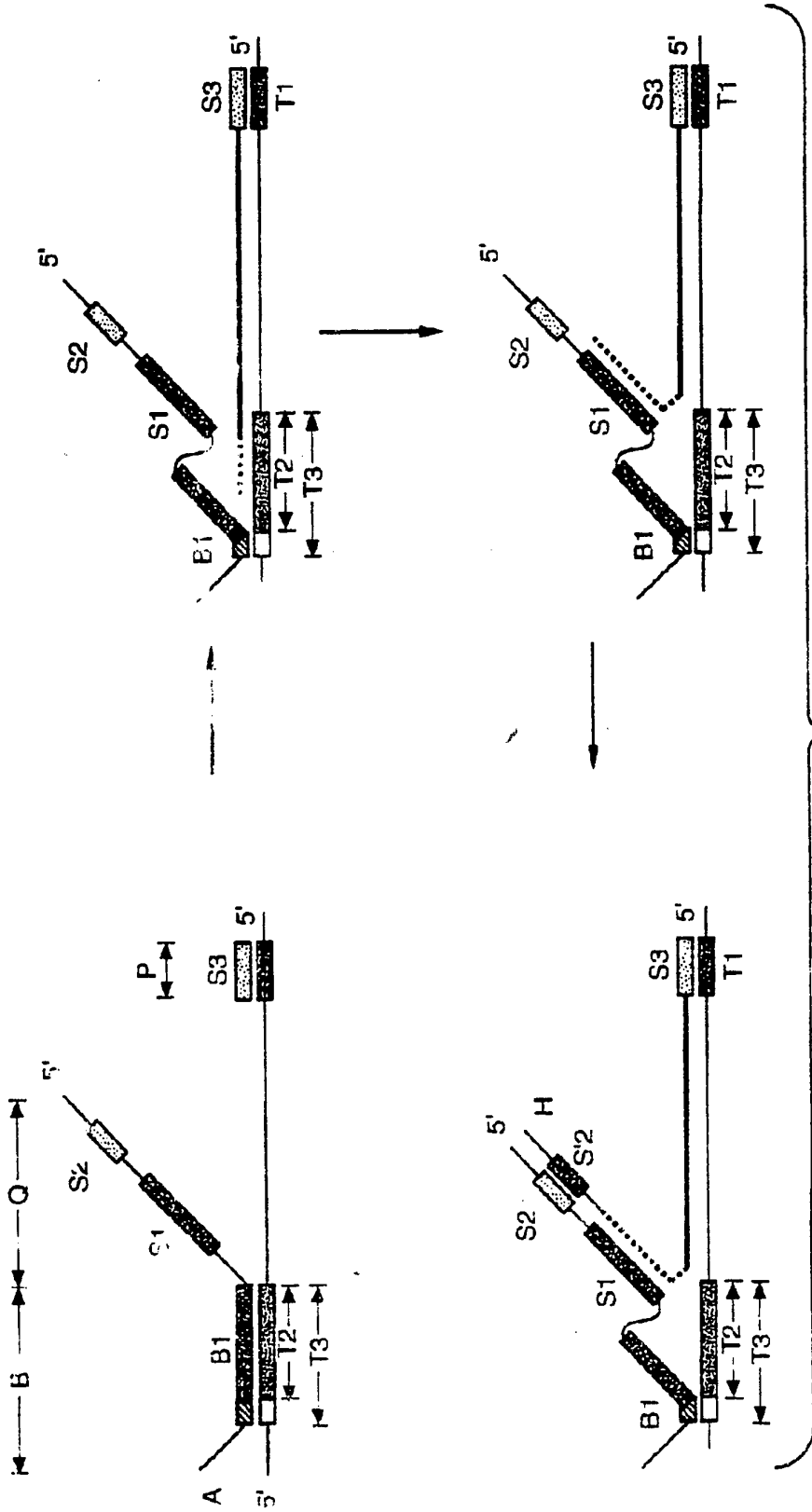

FIG. 5

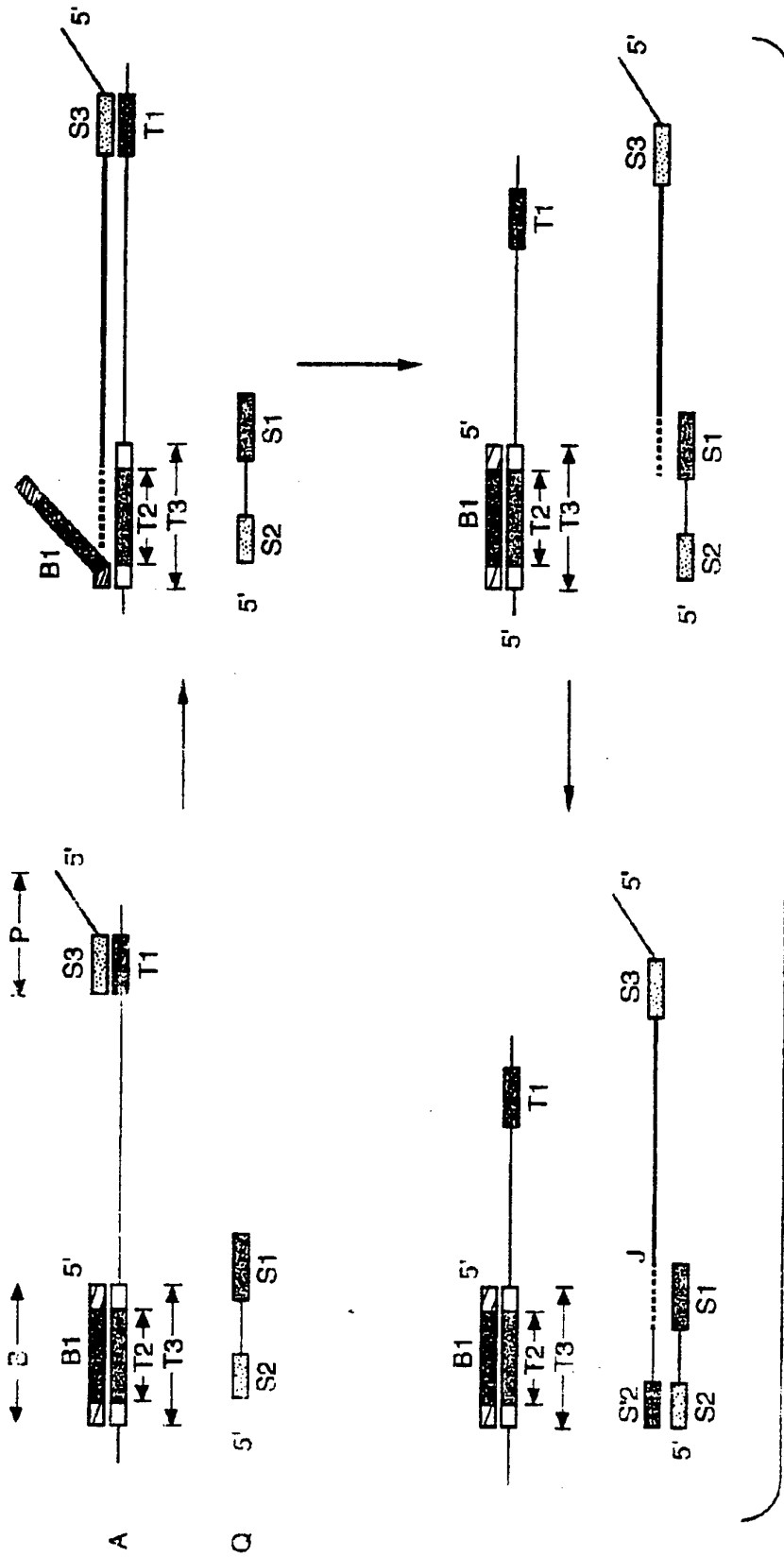

FIG. 6

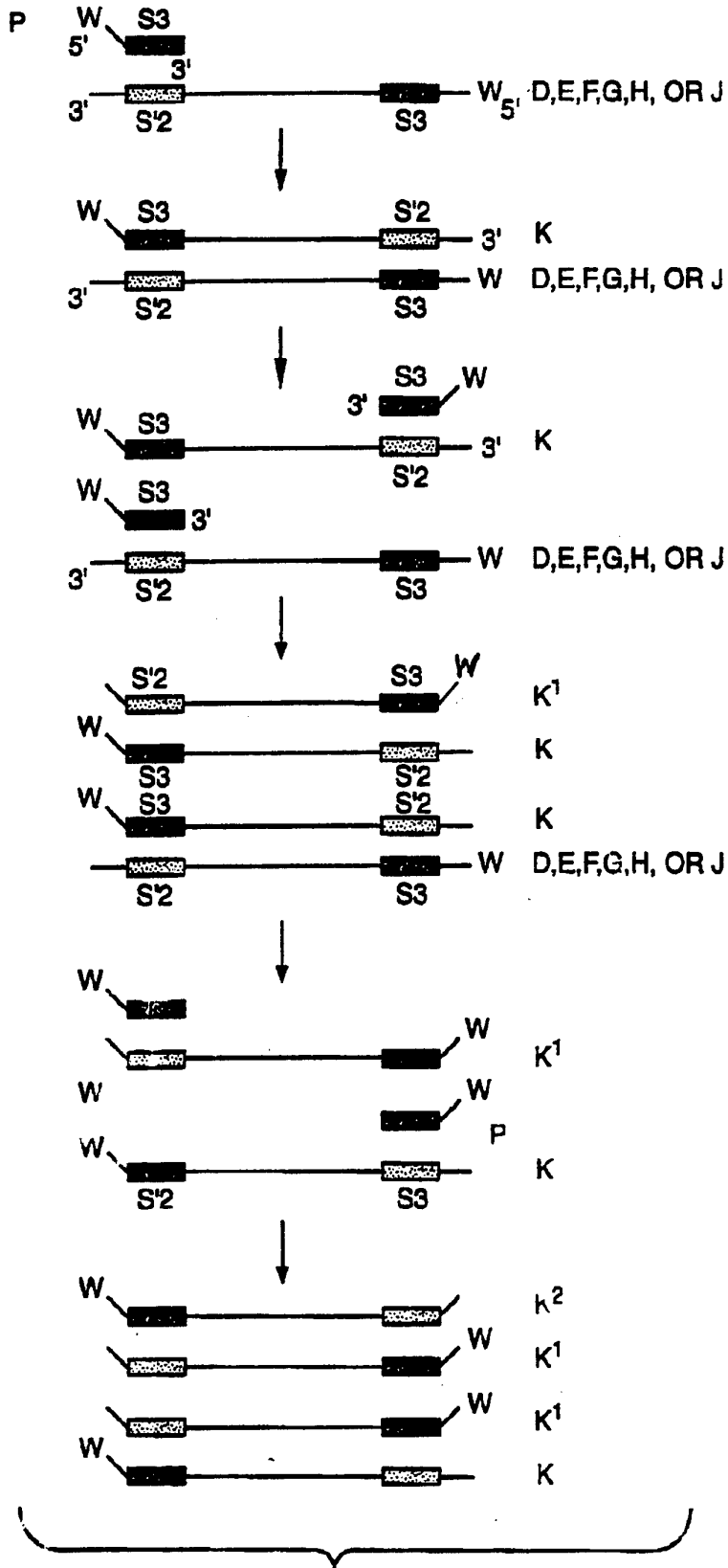

FIG. 7

8/16
LANE #

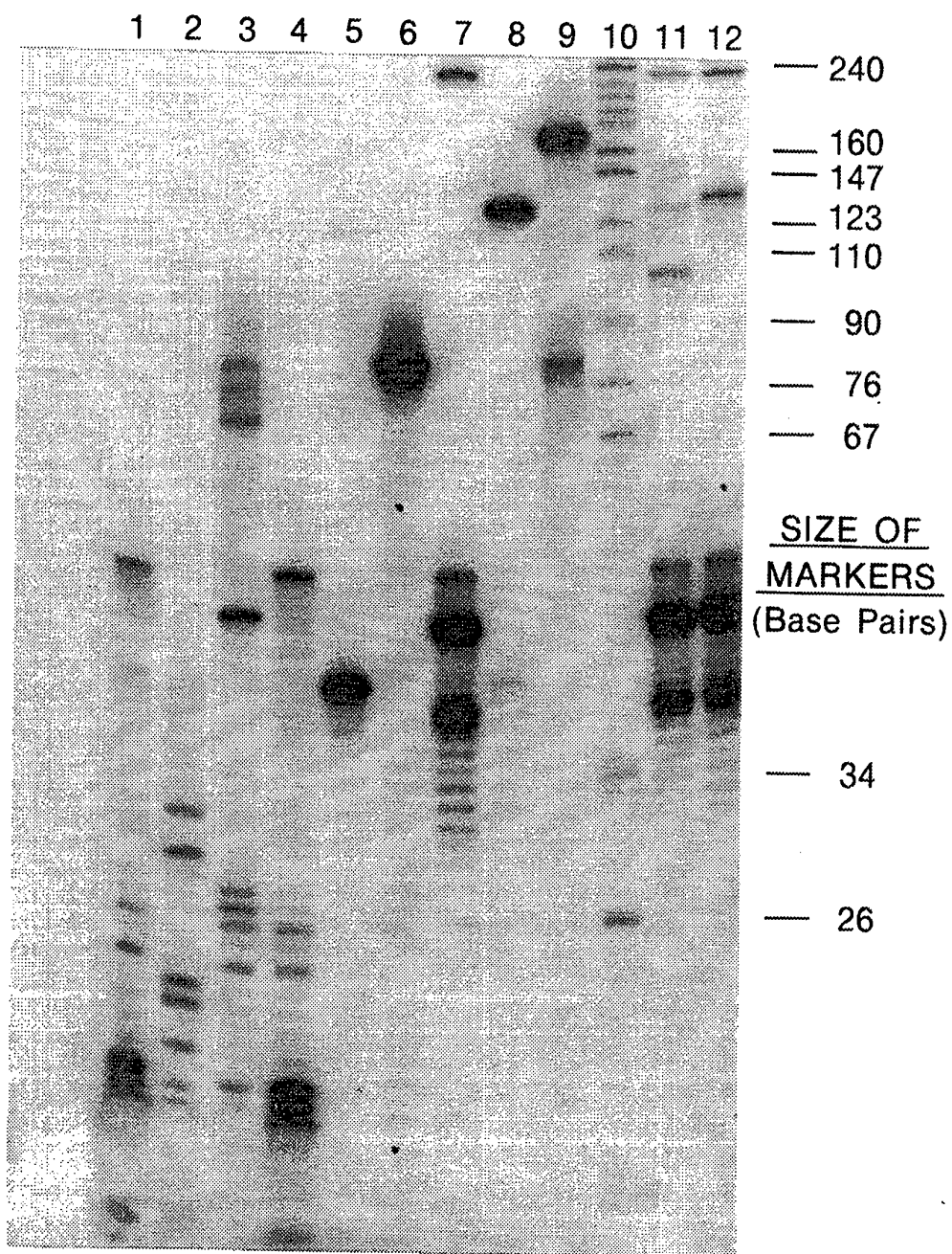
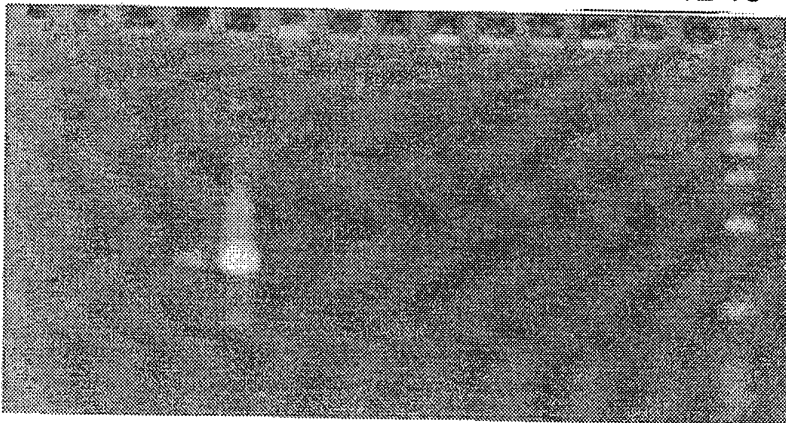

FIG.-8

9/16

LANE #

1 2 3 4 5 6 7 8 9 10 11 12 13



— 300
— 200
— 100
— 50

14 15 16 17 18 19 20 21 22 23 24 25 26

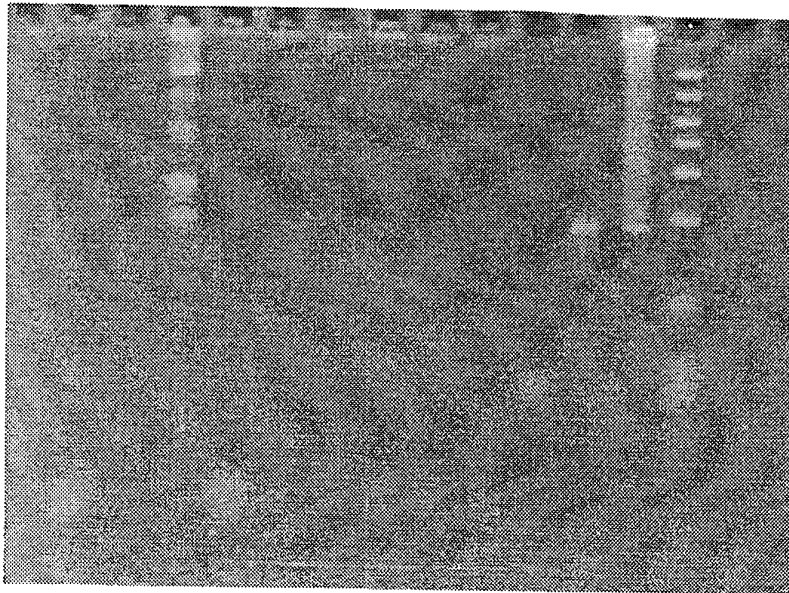

SIZE OF
MARKERS
(Base Pairs)

— 300
— 200
— 100
— 50

FIG.-9

10/16
LANE #

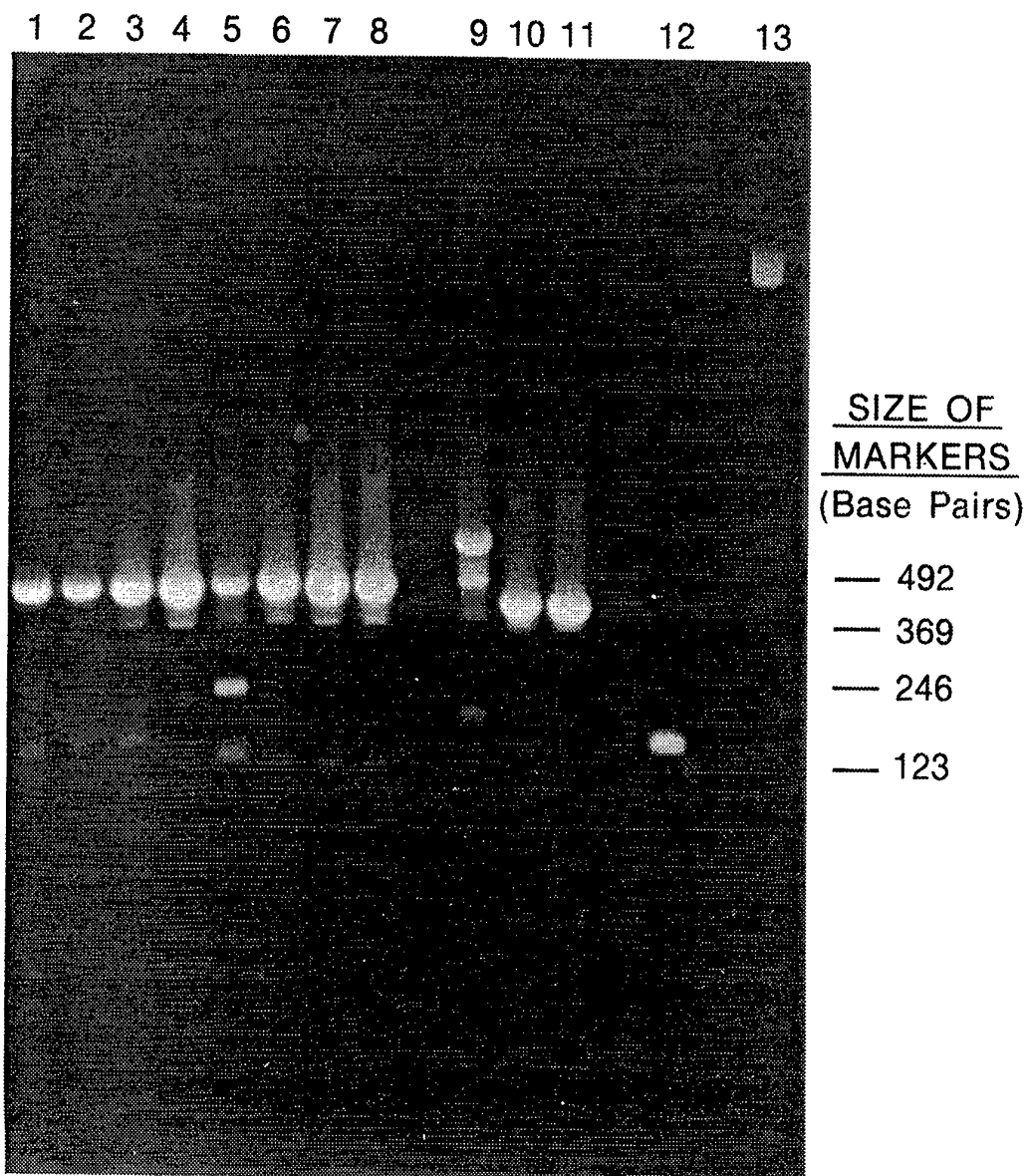

FIG.-10

11/16
LANE #

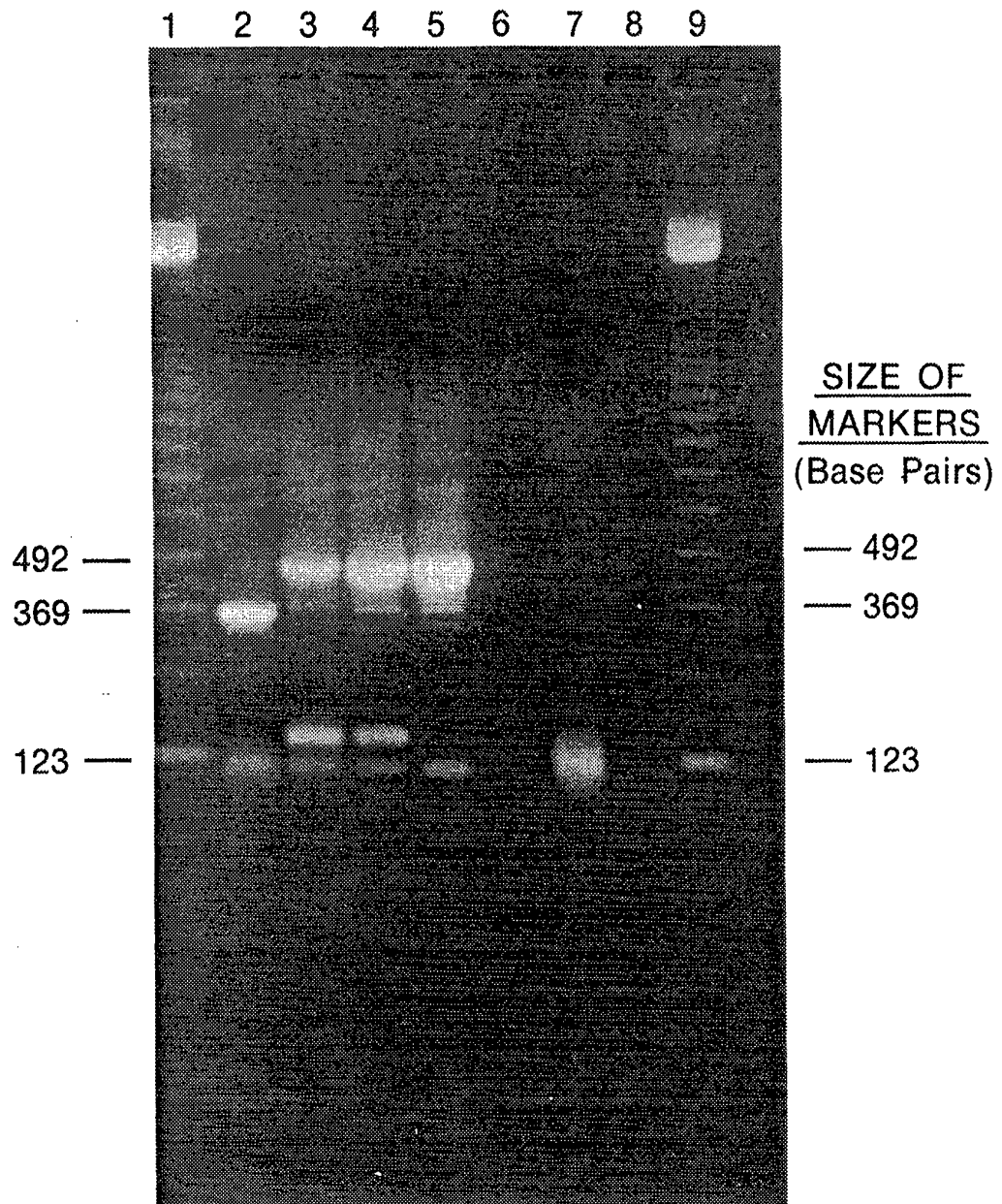

FIG.-11

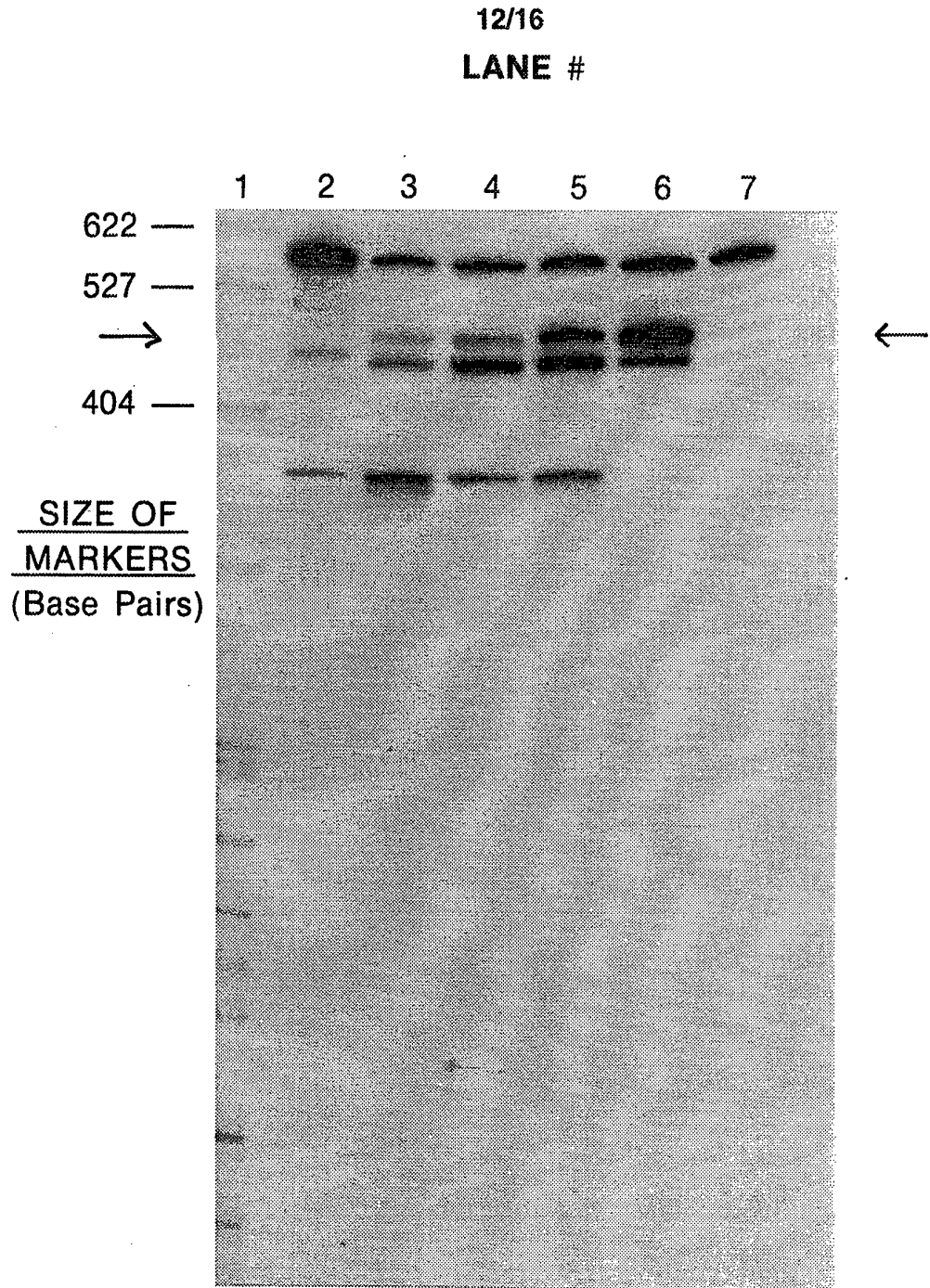
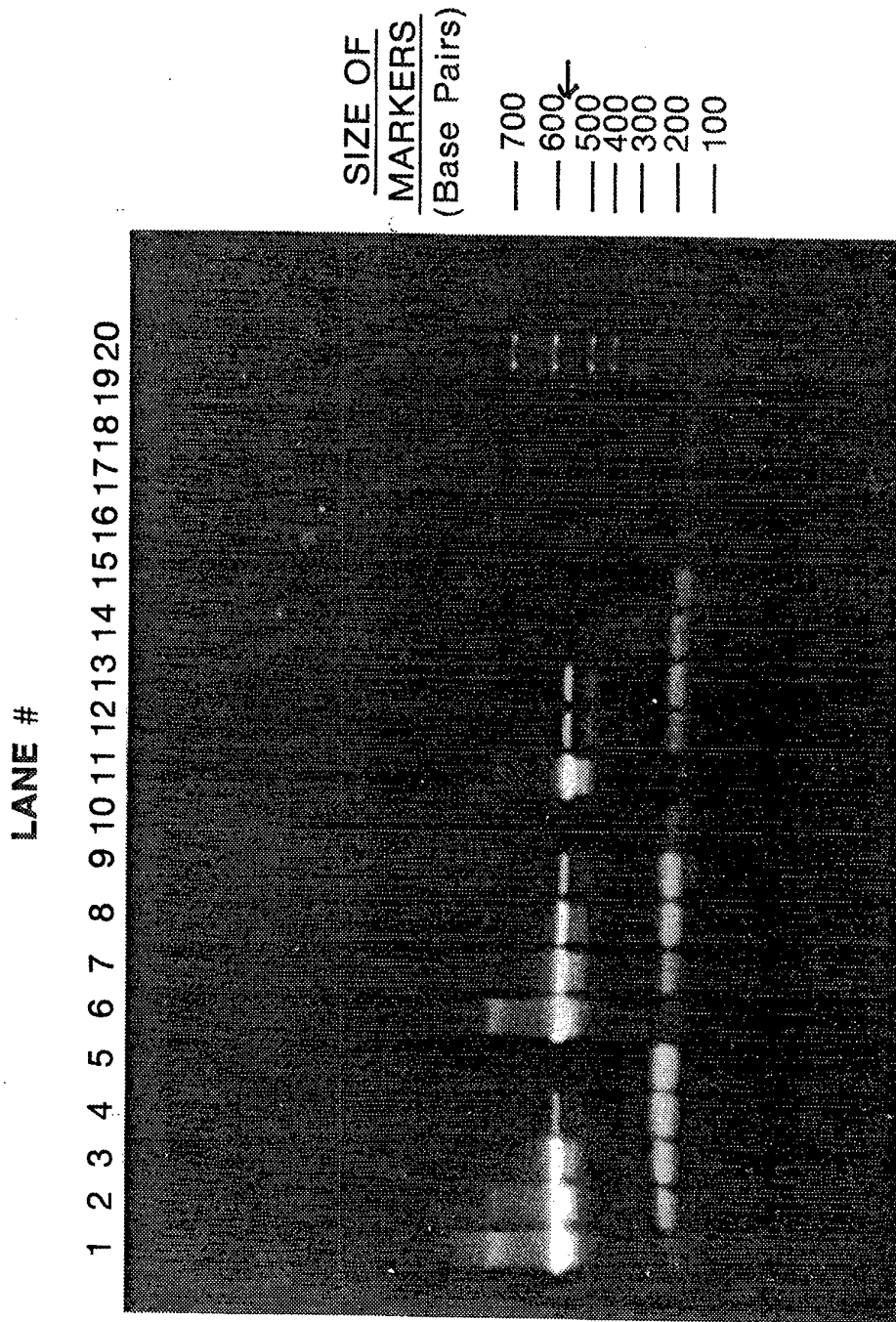

FIG.-12

13/16



↑
FIG.-13

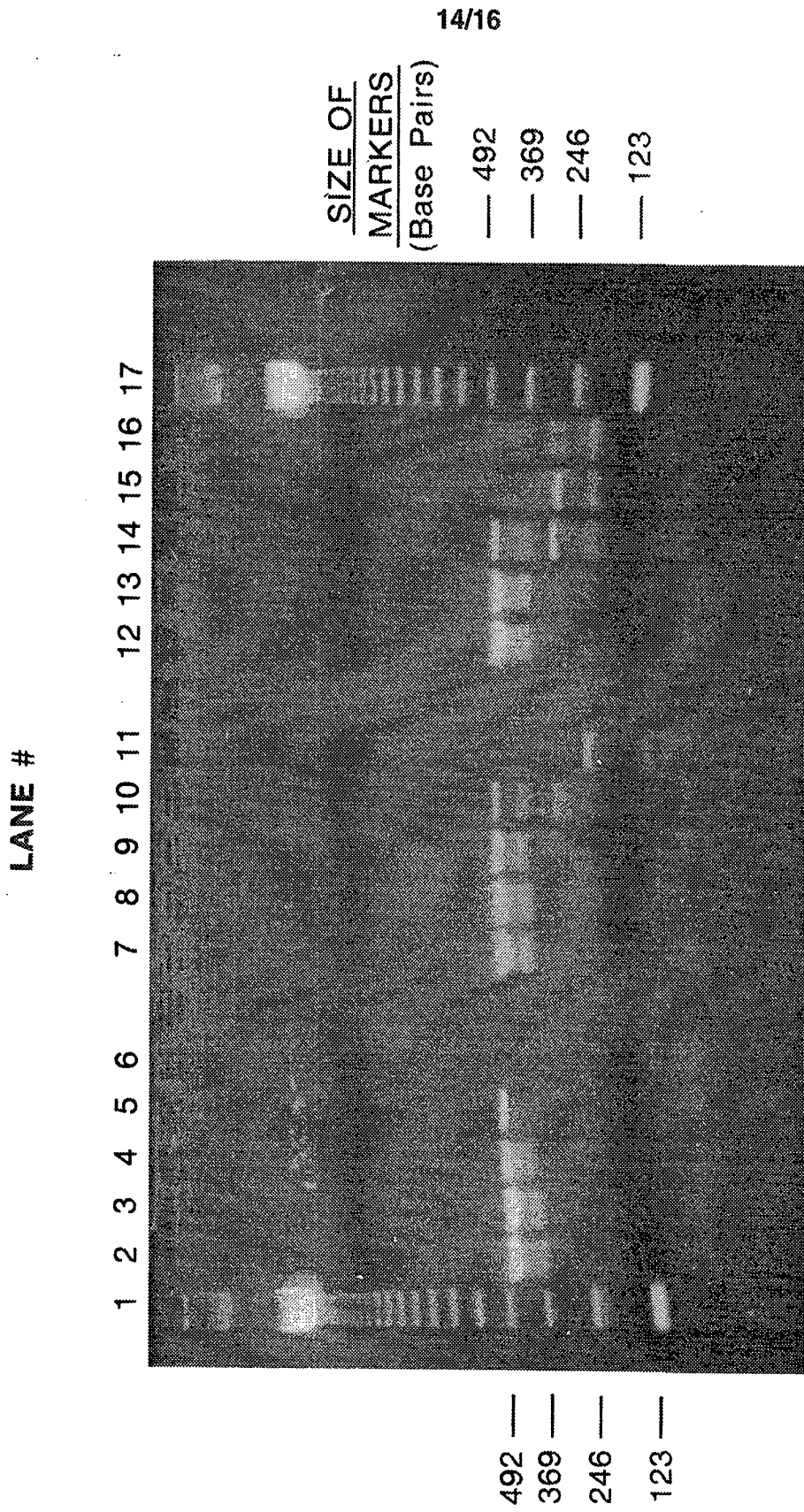

FIG.-14

SUBSTITUTE SHEET

15/16

LANE #

1 2 3 4 5 6 7 8 9 10 11 12 13 14 15 16 17 18 19 20 21 22

SIZE OF
MARKERS
(Base Pairs)

— 615
— 369
— 123

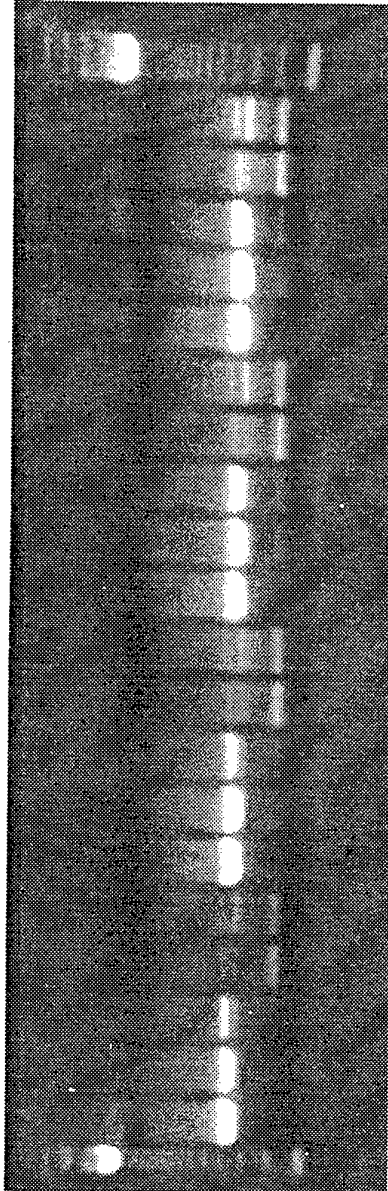

FIG.-15

16/16

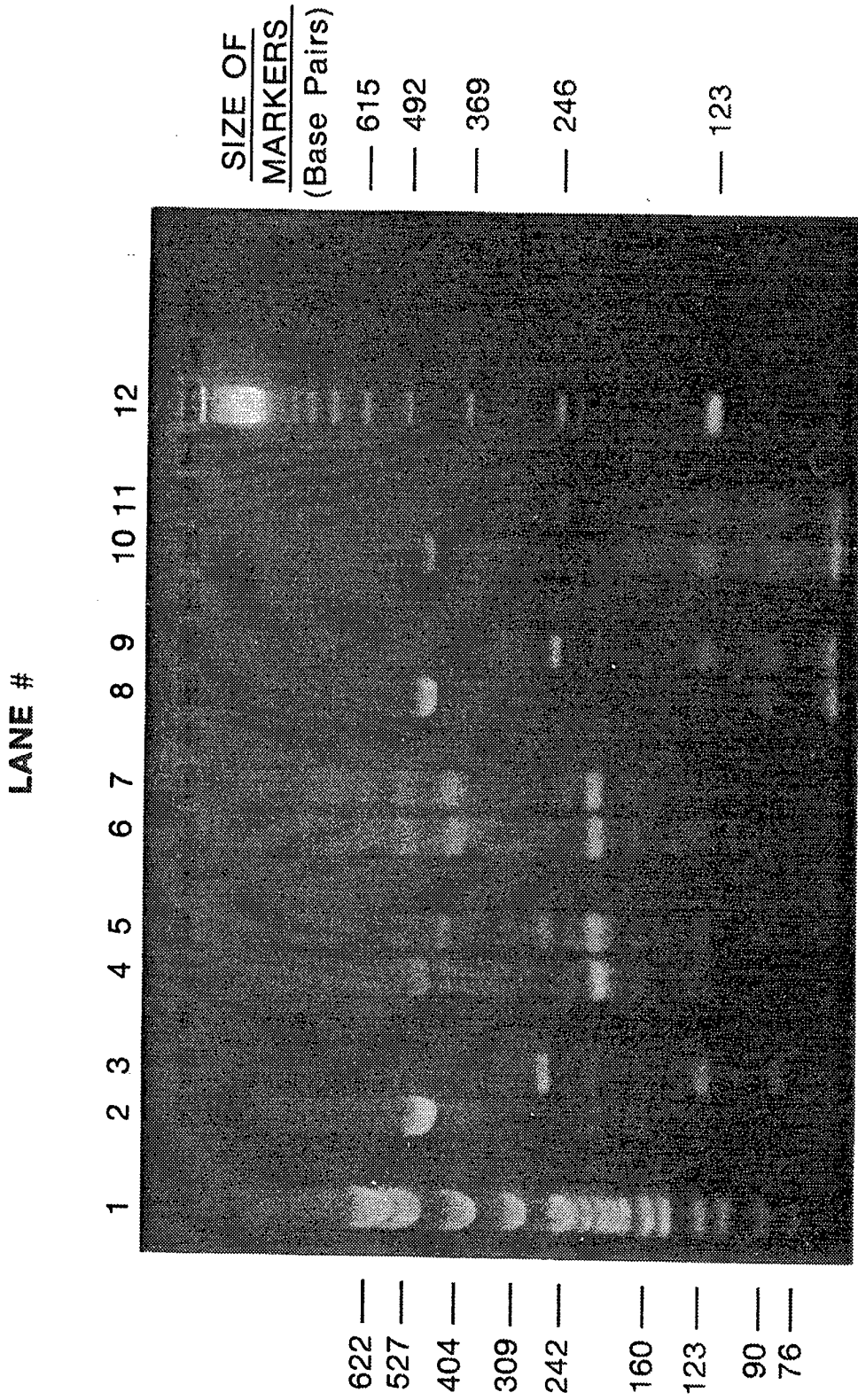

FIG.-16

SUBSTITUTE SHEET

INTERNATIONAL SEARCH REPORT

International Application No
PCT/US 93/07051

A. CLASSIFICATION OF SUBJECT MATTER IPC 5 C12Q1/68		
According to International Patent Classification (IPC) or to both national classification and IPC		
B. FIELDS SEARCHED		
Minimum documentation searched (classification system followed by classification symbols) IPC 5 C12Q		
Documentation searched other than minimum documentation to the extent that such documents are included in the fields searched		
Electronic data base consulted during the international search (name of data base and, where practical, search terms used)		
C. DOCUMENTS CONSIDERED TO BE RELEVANT		
Category *	Citation of document, with indication, where appropriate, of the relevant passages	Relevant to claim No.
Y	EP,A,0 469 755 (SYNTEX) 5 February 1992 cited in the application see the whole document ---	1
A	EP,A,0 318 245 (M.L. TECHNOLOGY VENTURES) 31 May 1989 cited in the application ---	
A	EP,A,0 379 369 (SYNTEX) 25 July 1990 cited in the application ---	
P,Y	EP,A,0 552 931 (GEN-PROBE INC.) 28 July 1993 see figures 15,18 ---	1
P,Y	WO,A,93 06240 (CYTOCELL LMT) 1 April 1993 see abstract; figure 1 -----	1
<input type="checkbox"/> Further documents are listed in the continuation of box C. <input checked="" type="checkbox"/> Patent family members are listed in annex.		
* Special categories of cited documents :		
A document defining the general state of the art which is not considered to be of particular relevance *E* earlier document but published on or after the international filing date *L* document which may throw doubts on priority claim(s) or which is cited to establish the publication date of another citation or other special reason (as specified) *O* document referring to an oral disclosure, use, exhibition or other means *P* document published prior to the international filing date but later than the priority date claimed		*T* later document published after the international filing date or priority date and not in conflict with the application but cited to understand the principle or theory underlying the invention *X* document of particular relevance; the claimed invention cannot be considered novel or cannot be considered to involve an inventive step when the document is taken alone *Y* document of particular relevance; the claimed invention cannot be considered to involve an inventive step when the document is combined with one or more other such documents, such combination being obvious to a person skilled in the art. *&* document member of the same patent family
Date of the actual completion of the international search 29 November 1993		Date of mailing of the international search report 29.12.93
Name and mailing address of the ISA European Patent Office, P.B. 5818 Patentlaan 2 NL - 2280 HV Rijswijk Tel. (+ 31-70) 340-2040, Tx. 31 651 epo nl, Fax: (+ 31-70) 340-3016		Authorized officer Molina Galan, E

INTERNATIONAL SEARCH REPORT

Information on patent family members

International Application No

PCT/US 93/07051

Patent document cited in search report	Publication date	Patent family member(s)	Publication date
EP-A-0469755	05-02-92	CA-A- 2047342 JP-A- 5084079	20-01-92 06-04-93
EP-A-0318245	31-05-89	US-A- 5030557 AU-A- 2611288 CA-A- 1319336 JP-T- 2502250 WO-A- 8904876	09-07-91 14-06-89 22-06-93 26-07-90 01-06-89
EP-A-0379369	25-07-90	CA-A- 2008096 JP-A- 2268683	19-07-90 02-11-90
EP-A-0552931	28-07-93	WO-A- 9315102	05-08-93
WO-A-9306240	01-04-93	AU-A- 2558692	27-04-93