

[54] **AUTOMATIC DOOR OPERATOR**
 [75] Inventors: **Andrew E. Scoville**, Ellington;
William R. Davis, West Simsbury,
 both of Conn.
 [73] Assignee: **The Stanley Works**, New Britain,
 Conn.
 [22] Filed: **June 7, 1973**
 [21] Appl. No.: **367,734**

[52] U.S. Cl. **250/221, 340/258 B**
 [51] Int. Cl. **H01j 39/12**
 [58] Field of Search..... 250/221, 222, 223;
 318/1-6, 480; 340/258 B; 340/228 S; 343/5
 DD, 6; 317/124

[56] **References Cited**

UNITED STATES PATENTS

2,946,931	7/1960	Durbin.....	250/221
3,086,146	4/1963	Edler.....	317/124
3,170,151	2/1965	Roth.....	250/221
3,546,467	12/1970	Benjamin.....	250/221
3,624,401	11/1971	Stoller.....	340/228 S
3,680,047	7/1972	Perlman.....	340/258 B
3,704,396	11/1972	MacDonald.....	250/221
3,723,738	3/1973	Brenner.....	343/5 DD

Primary Examiner—James W. Lawrence
 Assistant Examiner—D. C. Nelms
 Attorney, Agent, or Firm—Prutzman, Hayes, Kalb &
 Chilton

[57] **ABSTRACT**

A novel automatic traffic responsive control is provided for controlling the energization of the reversible drive of a powered door. The traffic control includes a traffic detector which is unobtrusive or invisible, does not require any special floor preparation of fixtures, or posts or guard rails at the entrance or the exit of the doorway, and is insensitive to the presence of the swinging door in one of the zones adjacent the door which must be monitored for safety and control reasons. The traffic control involves an emitter and a detector of radiant energy, e.g., infra red, with the emitter mounted by the header substantially on the hinge line and emitting a downwardly directed energy beam of a preselected divergence which spans the path of travel of traffic approaching the doorway. The sensor is mounted adjacent the opposite jamb and has its axis of sensitivity pointed transversely of the beam of energy to define in the intersection therewith, a three-dimensional control zone in which the presence of traffic is detected by reflected radiant energy. In the preferred embodiment, the bottom plane of the control zone is substantially parallel to the floor and the radiant energy is coded to render the control insensitive to ambient radiations.

9 Claims, 3 Drawing Figures

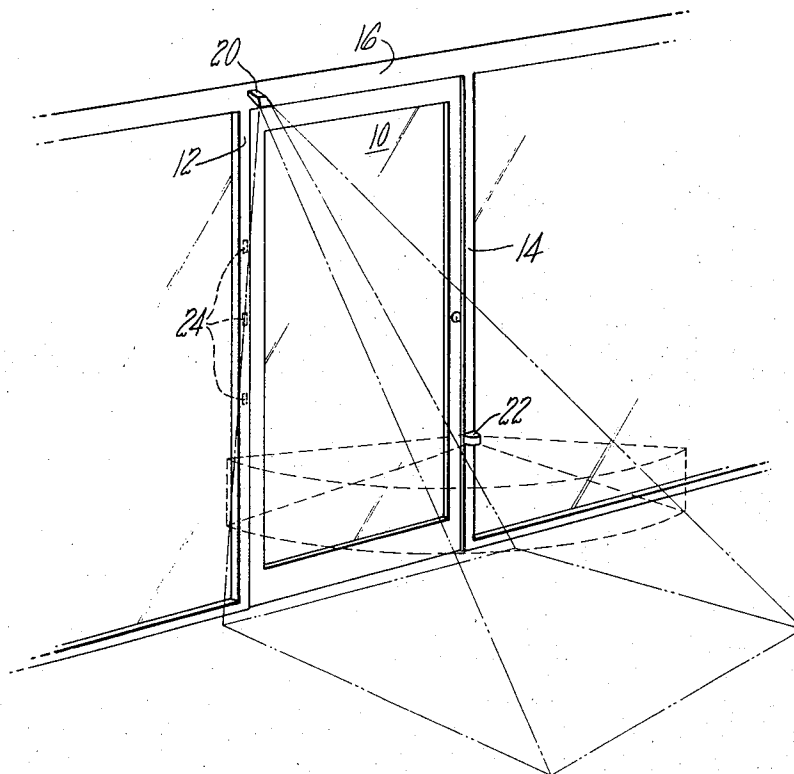

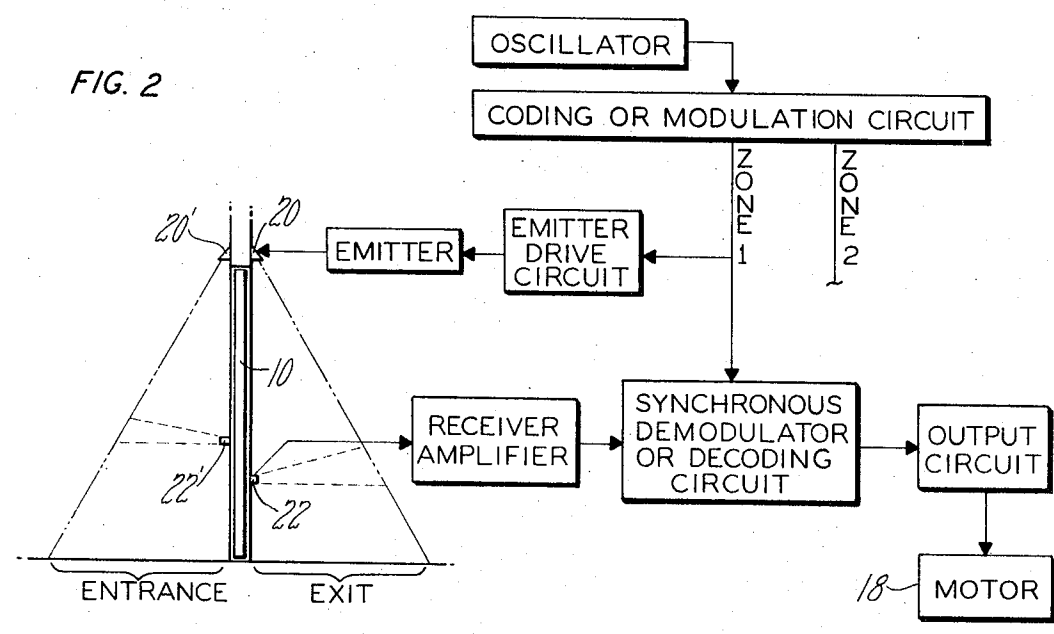
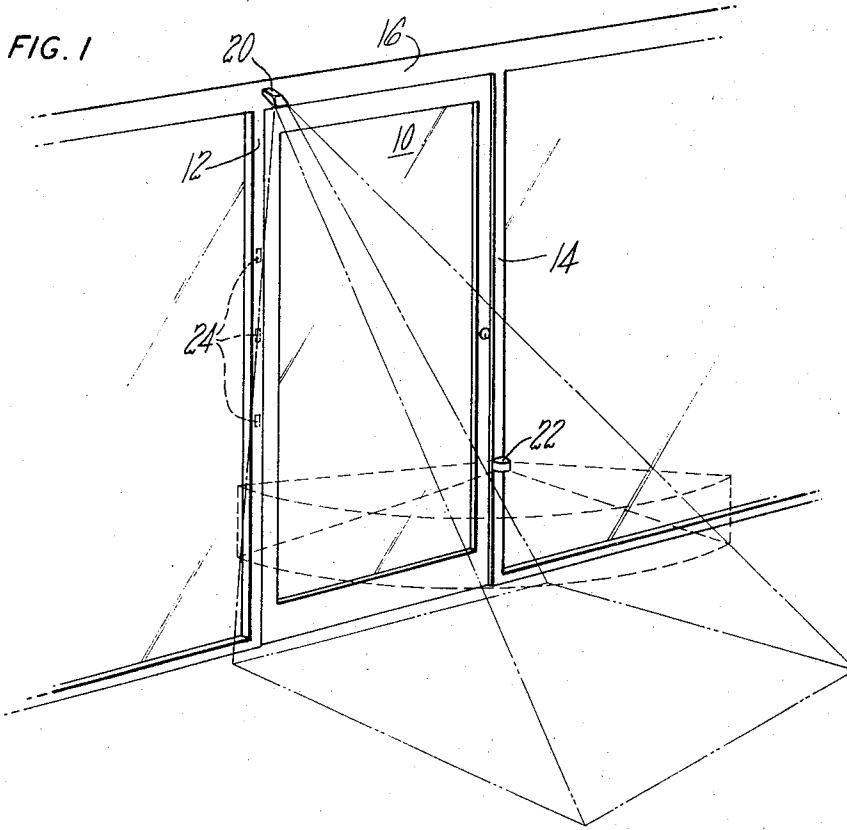

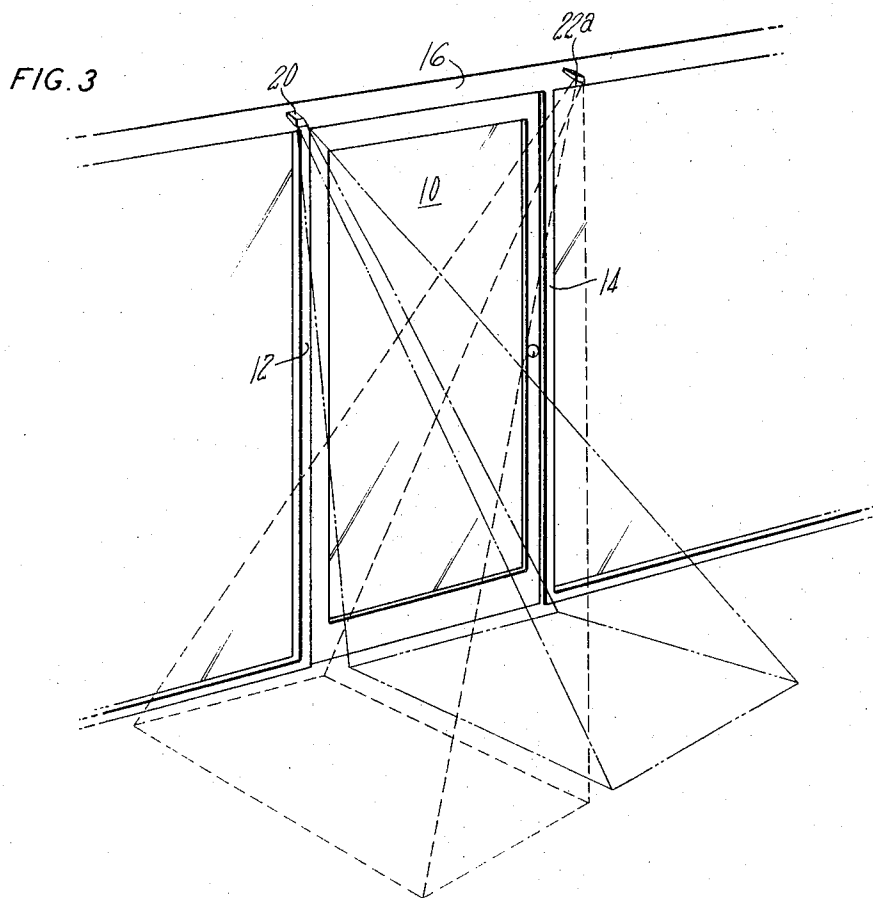

AUTOMATIC DOOR OPERATOR

This invention relates to an automatic door operator and, more particularly, to such an operator having a traffic detecting and sensing control which is unobtrusive in appearance, reliable in operation, requires no special floor preparation or fixtures at the approaches to the doorway, and is suited for use with any doorway motif. The primary object of this invention is to provide an automatic door operator having such a traffic detecting and sensing control.

A further object of this invention is to provide an unobtrusive traffic detector for initiating and controlling an automatic operator for a powered door involving a transmitter and a receiver of radiant energy for sensing the presence of a body in prescribed three-dimensional zones of space adjacent the entrance and exit sides of the door with the zones being adjustable and variable in height, size, and location to accommodate the special requirements of the safety and entrance sides of diverse doorways.

Another object of this invention is the provision of a radiant energy traffic detection system for an automatic door operator for a swinging door including means for discriminating between the presence of traffic on the entrance and exit sides of a door and to eliminate false actuation by spurious signals and ambient radiations.

A further object of this invention is to provide a radiant energy detection system for door operators including spaced transmitters and receivers of radiant energy having axes disposed transversely to each other to provide an intersecting three dimensional control zone for detecting the presence of a body within the zone of intersection. Included in this object is the provision of such a system wherein reflected radiant energy from the body is detected to sense the presence of a body in the zone of intersection.

Still another object of this invention is the provision of a reflective radiant energy traffic sensor for controlling a swinging door which is insensitive to the presence of the door in the control zone of the doorway.

Other objects will be in part obvious and in part pointed out more in detail hereinafter.

A better understanding of the invention will be obtained from the following detailed description and the accompanying drawing of an illustrative application of the invention.

In the drawings:

FIG. 1 is a schematic perspective view of an illustrative operator embodying the teachings of this invention; and

FIG. 2 shows a side view and block diagram of the operator of FIG. 1.

FIG. 3 is a schematic perspective view, similar to FIG. 1, illustrating another embodiment of the invention.

Referring now to the drawings in detail, there is schematically shown an exemplary embodiment of the present invention. As shown, a door 10 is mounted in a doorway formed by jambs 12,14 and header 16 and is hinged for swinging movement in a conventional manner along a hinge line adjacent the jamb 12.

A reversible drive including a motor 18 of any suitable type is connected to the door in a conventional manner (not shown) to power the door through a door

opening and door closing cycle in response to traffic through the doorway.

In accordance with this invention, a novel automatic traffic responsive control is provided for controlling the energization of the reversible drive. The traffic control includes a traffic detector which may be unobtrusive or invisible and does not require any special floor preparation or fixtures, or posts or guard rails on the entrance or the exit of the doorway, and is insensitive to the presence of the swinging door in one of the zones adjacent the door which must be monitored for safety and control reasons. Moreover, the traffic control of this invention is based on the use of radiant energy and involves emitter and detector means so positioned and controlled as to define a clearly defined three-dimensional control zone in which the presence of traffic is detected by reflected radiant energy while being insensitive to ambient radiations.

As shown in the illustrative embodiment, an emitter 20 of radiant energy, e.g., a gallium arsenide emitter of infra red energy having a wave length of about 9,000 Angstrom units, is disposed above the doorway on the hinged edge of the door and emits a downwardly directed energy beam of a preselected divergence as illustrated in phantom lines so as to span the path of travel of traffic approaching the doorway.

A sensor 22 of radiant energy is shown as being mounted by the jamb 14 adjacent the floor on the edge of the door opposite the hinge line and has its axis of sensitivity pointed transversely to the beam of energy emitted by the emitter 20 to define in the intersection therewith a three-dimensional zone which is common to both and does not normally include any solid body. Preferably the axis of sensitivity of the sensor 22 should be about 90° with respect to the beam of energy emitted by the emitter 20 to optimize the size of the three-dimensional control zone and provide a high efficiency of reflected radiation which is detected by the sensor 22. However, adequate efficiency of reflection may be achieved at angles of up to about 150° and angles of down to about 30° can generally be used to provide an adequate three-dimensional control zone for an automatic door which does not include the floor. In this regard, it will be observed that the bottom plane of the three-dimensional control zone is disclosed as being substantially parallel to the floor and that it does not include any wall or solid object.

When a solid object, such as a pedestrian using the doorway, enters the three-dimensional control zone, the radiant energy emitted by emitter 20 is reflected by the pedestrian and sensed by the sensor 22 to actuate the door, and retain the door in the open position until the pedestrian passes from the three-dimensional control zone.

The control for a swinging door must sense the presence of traffic or an obstacle on both sides of the door for control and safety purposes to give assurance that the door will open and also that the door will not injure a person or object positioned in the path of the door as it swings open. Moreover, it is desirable that a door be responsive to a person wishing to use the door but not responsive to a dog or other small animal. At the same time it is desirable that the sensor detect the presence of a child or small object lying in the path of the swinging door as it opens. This invention, by virtue of its easy adaptability to provide a clearly defined control zone spaced a variable distance above the floor readily

achieves this requirement by the simple expedient of mounting the sensor, or detector, 22 on the side of the door toward which the door swings at a lower level than the sensor 22' on the other side of the door. Because of the clear definition possible in the bottom plane of the three-dimensional control zone through the use of this invention, a precise height sensitivity is provided.

According to another aspect of this invention, the control can discriminate between the entry of traffic into the three-dimensional control zone and the entry of the door. Since the sensor 22 senses reflected energy only from a body which presents a reflecting surface within the three-dimensional control zone and the emitter 20 is on the hinge line of the door, the only surface of the door which can reflect energy emitted by emitter 20 is the top surface of the door which is not within the intersecting control zone. Thus, the sensor does not sense the presence of the door in the control zone and the door does not act to keep the door open once it is opened.

The radiant energy emitted by emitter 20 may produce pulses which are coded by various known means and the sensor 22 and the associated control circuit for controlling the motor 18 may include means to render the circuit responsive solely to the coded output of emitter 20 to avoid false actuation of the door due to spurious signals and ambient radiations or noise. Moreover, by coding the emissions of emitter 20 and 20' differently any cross-coupling or interference between different control zones is minimized. The use of coded or modulated emissions provides selectivity so that the detection and control circuit can discriminate between reflected radiations from traffic in the three-dimensional zone and other sources of radiation, e.g., direct or reflected solar energy.

Instead of using a single emitter or sensor for sensing traffic on one side of a door, multiple sensors 22 and/or emitters 20 may be used. For example, a plurality of emitters 24 located on the jamb 12 may be used as a substitute for the illustrated emitter 20 or as supplementary thereto to provide increased versatility because of larger three-dimensional control zones into which the emitted energy is radiated, or by eliminating or minimizing blind spots in a control zone.

FIG. 3 illustrates another modified form of the invention wherein an emitter 20 and a sensor 22a are both mounted on the header for the door and are pointed to define a three-dimensional control zone on the path of travel approaching the doorway and in which the reflected energy from the emitter 20 is detected by the sensor 22a.

The sensor 22a and the emitter 20 are spaced apart by being located adjacent opposite edges of the door and their axes are pointed so that the three-dimensional control zone defined by the intersection of their beams does not include a surface, e.g., the top surface, of the door form which energy from the emitter would be detected by the sensor, and also does not include a common portion of the floor. Sensor 22a can be used as a single sensor or as a supplementary sensor depending upon the specific application. Where a sensor is pointed toward the floor or another solid object, coded

emissions should be used with a control circuit which can discriminate between reflected radiations from traffic in the control zone and changes in ambient levels of radiation e.g. due to solar energy.

As will be apparent to persons skilled in the art, various modifications, adaptations and variations of the foregoing specific disclosure can be made without departing from the teachings of the present invention.

We claim:

1. An automatic door operator comprising a reversible drive including a drive motor for powering a door through a door opening and door closing cycle and a traffic responsive control therefor, said traffic responsive control comprising radiant energy emitter means for emitting a divergent beam of radiant energy spanning the path of travel of traffic through the door and radiant energy detector means spaced from said emitter and having an axis of sensitivity disposed transversely of said beam of radiant energy to intersect said beam and define in the intersection thereof a discrete divergent three-dimensional control zone for sensing diffuse reflected radiant energy from traffic within said three-dimensional control zone to control the actuation of said reversible drive, said three-dimensional control zone being spaced above and having a lower boundary substantially parallel to the floor along said path of travel of traffic through the door.

2. The automatic door operator of claim 1 wherein such a fixed three-dimensional control zone is provided on both the entrance and exit sides of the door.

3. The automatic door operator of claim 2 wherein the three-dimensional control zone on the side of the door toward which the door swings is spaced closer to the floor than the three-dimensional control zone on the other side.

4. The automatic door operator of claim 1 wherein one of said emitter and detector means is located above the door and the other is located at the side of the door.

5. The automatic door operator of claim 4 wherein the door opens into the three-dimensional control zone and said one of said emitter and detector means located above the door is disposed substantially on the hinge line of the door.

6. The automatic door operator of claim 5 wherein the other of said emitter and detector means is located adjacent the jamb on the side of the door opposite the hinge line.

7. The automatic door operator of claim 6 wherein said emitter means is located on the hinge line of the door.

8. The automatic door operator of claim 1 wherein the output of the emitter means is coded and the detector means is sensitive only to the coded output of the associated emitter means.

9. The automatic door operator of claim 8 wherein one of said emitter and detector means is located adjacent the top of the door near the hinge line of the door and the other of said emitter and detector means is located adjacent the top of the door on the side of the door opposite the hinge line.

* * * * *