



Europäisches Patentamt
European Patent Office
Office européen des brevets



(11) **EP 0 774 567 B1**

(12) **EUROPEAN PATENT SPECIFICATION**

(45) Date of publication and mention
of the grant of the patent:
26.06.2002 Bulletin 2002/26

(51) Int Cl.7: **F01D 5/14, F04D 29/38**

(21) Application number: **96308303.5**

(22) Date of filing: **15.11.1996**

(54) **Swept turbomachinery blade**

Gepfeilte Turbomaschinenschaufel

Aubes de turbines en flèche

(84) Designated Contracting States:
DE FR GB

(30) Priority: **17.11.1995 US 559965**

(43) Date of publication of application:
21.05.1997 Bulletin 1997/21

(60) Divisional application:
01112128.2 / 1 138 877

(73) Proprietor: **UNITED TECHNOLOGIES
CORPORATION
Hartford, CT 06101 (US)**

(72) Inventors:
• **Spear, David A.
Manchester, Connecticut 06040 (US)**

• **Biederman, Bruce P.
Meriden, Connecticut 06450 (US)**
• **Orosa, John A.
Palm Beach Gardens, Florida 33410 (US)**

(74) Representative: **Leckey, David Herbert
Frank B. Dehn & Co.,
European Patent Attorneys,
179 Queen Victoria Street
London EC4V 4EL (GB)**

(56) References cited:
WO-A-91/07593 **FR-A- 2 459 387**
US-A- 2 934 259 **US-A- 3 989 406**
US-A- 4 012 172

EP 0 774 567 B1

Note: Within nine months from the publication of the mention of the grant of the European patent, any person may give notice to the European Patent Office of opposition to the European patent granted. Notice of opposition shall be filed in a written reasoned statement. It shall not be deemed to have been filed until the opposition fee has been paid. (Art. 99(1) European Patent Convention).

Description

[0001] This invention relates to turbomachinery blades, and particularly to blades whose airfoils are swept to minimize the adverse effects of supersonic flow of a working medium over the airfoil surfaces.

[0002] Gas turbine engines employ cascades of blades to exchange energy with a compressible working medium gas that flows axially through the engine. Each blade in the cascade has an attachment which engages a slot in a rotatable hub so that the blades extend radially outward from the hub. Each blade has a radially extending airfoil, and each airfoil cooperates with the airfoils of the neighboring blades to define a series of interblade flow passages through the cascade. The radially outer boundary of the flow passages is formed by a case which circumscribes the airfoil tips. The radially inner boundary of the passages is formed by abutting platforms which extend circumferentially from each blade.

[0003] During engine operation the hub, and therefore the blades attached thereto, rotate about a longitudinally extending rotational axis. The velocity of the working medium relative to the blades increases with increasing radius. Accordingly, it is not uncommon for the airfoil leading edges to be swept forward or swept back to mitigate the adverse aerodynamic effects associated with the compressibility of the working medium at high velocities.

[0004] One disadvantage of a swept blade results from pressure waves which extend along the span of each airfoil suction surface and reflect off the surrounding case. Because the airfoil is swept, both the incident waves and the reflected waves are oblique to the case. The reflected waves interact with the incident waves and coalesce into a planar aerodynamic shock which extends across the interblade flow channel between neighboring airfoils. These "endwall shocks" extend radially inward a limited distance from the case. In addition, the compressibility of the working medium causes a passage shock, which is unrelated to the above described endwall shock, to extend across the passage from the leading edge of each blade to the suction surface of the adjacent blade. As a result, the working medium gas flowing into the channels encounters multiple shocks and experiences unrecoverable losses in velocity and total pressure, both of which degrade the engine's efficiency.

[0005] An example of a prior art swept blade is described in US 4012172. This prior art blade has a leading edge comprising an intermediate region that is swept forward from its hub, up to a point of sweep reversal, and then swept rearwardly to the tip of the blade.

[0006] What is needed is a turbomachinery blade whose airfoil is swept to mitigate the effects of working medium compressibility while also avoiding the adverse influences of multiple shocks.

[0007] The invention seeks to minimize the aerodynamic losses and efficiency degradation associated

with endwall shocks by limiting the number of shocks in each interblade passage by providing: a swept fan blade for a gas turbine engine as claimed in claim 1.

[0008] Thus when the blades are used in turbomachinery having a cascade of blades rotatable about a rotational axis, wherein each blade in the cascade has a leading neighbor and a trailing neighbor, and each blade cooperates with its neighbours to define flow passages for a working medium gas, the swept blades are configured such that a section of each blade radially co-extensive with the endwall shock extending from its leading neighbor will intercept the endwall shock so that the endwall shock and the passage shock are coincident.

[0009] Thus, a blade for a blade cascade has an airfoil which is swept over at least a portion of its span, and the section of the airfoil radially coextensive with the endwall shock intercepts the endwall shock extending from the neighboring airfoil so that the endwall shock and the passage shock are coincident. This has the advantage of limiting the number of shocks in each interblade passage so that engine efficiency is maximised.

[0010] In one embodiment the axially forwardmost extremity of the airfoil's leading edge defines an inner transition point located at an inner transition radius radially inward of the airfoil tip.

[0011] Some preferred embodiments of the present invention will now be described, by way of example only, with reference to the accompanying drawings in which:

[0012] Figure 1 is a cross sectional side elevation of the fan section of a gas turbine engine showing a swept back fan blade embodying to the present invention.

[0013] Figure 2 is an enlarged view of the blade of Fig. 1 including an alternative leading edge profile shown by dotted lines and a prior art blade shown in phantom.

[0014] Figure 3 is a developed view taken along the line 3-3 of Fig. 2 illustrating the tips of four blades of the present invention along with four prior art blades shown in phantom.

[0015] Figure 4 is a schematic perspective view of an airfoil fragment illustrating the definition of sweep angle.

[0016] Figure 5 is a developed view similar to Figure 3 illustrating an alternative embodiment of the invention and showing prior art blades in phantom.

[0017] Figure 6 is a cross sectional side elevation of the fan section of a gas turbine engine showing a forward swept fan blade which does not fall within the scope of the present invention.

[0018] Figure 7 is a developed view taken along the line 7-7 of Fig. 6.

[0019] Referring to Figures 1-3, the forward end of a gas turbine engine includes a fan section 10 having a cascade of fan blades 12. Each blade has an attachment 14 for attaching the blade to a disk or hub 16 which is rotatable about a longitudinally extending rotational axis 18. Each blade also has a circumferentially extending platform 20 radially outward of the attachment. When installed in an engine, the platforms of neighbor-

ing blades in the cascade abut each other to form the cascade's inner flowpath boundary. An airfoil 22 extending radially outward from each platform has a root 24, a tip 26, a leading edge 28, a trailing edge 30, a pressure surface 32 and a suction surface 34. The axially forwardmost extremity of the leading edge defines an inner transition point 40 at an inner transition radius $r_{t\text{-inner}}$, radially inward of the tip. The blade cascade is circumscribed by a case 42 which forms the cascade's outer flowpath boundary. The case includes a rubstrip 46 which partially abrades away in the event that a rotating blade contacts the case during engine operation. A working medium fluid such as air 48 is pressurized as it flows axially through interblade passages 50 between neighboring airfoils.

[0020] The hub 16 is attached to a shaft 52. During engine operation, a turbine (not shown) rotates the shaft, and therefore the hub and the blades, about the axis 18 in direction R. Each blade, therefore, has a leading neighbor which precedes it and a trailing neighbor which follows it during rotation of the blades about the rotational axis.

[0021] The axial velocity V_x (Fig 3) of the working medium is substantially constant across the radius of the flowpath. However the linear velocity U of a rotating airfoil increases with increasing radius. Accordingly, the relative velocity V_r of the working medium at the airfoil leading edge increases with increasing radius, and at high enough rotational speeds, the airfoil experiences supersonic working medium flow velocities in the vicinity of its tip. Supersonic flow over an airfoil, while beneficial for maximizing the pressurization of the working medium, has the undesirable effect of reducing fan efficiency by introducing losses in the working medium's velocity and total pressure. Therefore, it is typical to sweep the airfoil's leading edge over at least a portion of the blade span so that the working medium velocity component in the chordwise direction (perpendicular to the leading edge) is subsonic. Since the relative velocity V_r increases with increasing radius, the sweep angle typically increases with increasing radius as well. As shown in Figure 4, the sweep angle σ at any arbitrary radius is the acute angle between a line 54 tangent to the leading edge 28 of the airfoil 22 and a plane 56 perpendicular to the relative velocity vector V_r . The sweep angle is measured in plane 58 which contains both the relative velocity vector and the tangent line and is perpendicular to plane 56. In conformance with this definition sweep angles σ_1 and σ_2 , referred to hereinafter and illustrated in Figures 2, 3 and 6 are shown as projections of the actual sweep angle onto the plane of the illustrations.

[0022] Sweeping the blade leading edge, while useful for minimizing the adverse effects of supersonic working medium velocity, has the undesirable side effect of creating an endwall reflection shock. The flow of the working medium over the blade suction surface generates pressure waves 60 (shown only in Fig. 1) which extend along the span of the blade and reflect off the case. The

reflected waves 62 and the incident waves 60 coalesce in the vicinity of the case to form an endwall shock 64 across each interblade passage. The endwall shock extends radially inward a limited distance, d , from the case.

As best seen in the prior art (phantom) illustration of Figure 3, each endwall shock is also oblique to a plane 67 perpendicular to the rotational axis so that the shock extends axially and circumferentially. In principle, an endwall shock can extend across multiple interblade passages and affect the working medium entering those passages. In practice, expansion waves (as illustrated by the representative waves 68) propagate axially forward from each airfoil and weaken the endwall shock from the airfoil's leading neighbor so that each endwall shock usually affects only the passage where the endwall shock originated. In addition, the supersonic character of the flow causes passage shocks 66 to extend across the passages. The passage shocks, which are unrelated to endwall reflections, extend from the leading edge of each blade to the suction surface of the blade's leading neighbor. Thus, the working medium is subjected to the aerodynamic losses of multiple shocks with a corresponding degradation of engine efficiency.

[0023] The endwall shock can be eliminated by making the case wall perpendicular to the incident expansion waves so that the incident waves coincide with their reflections. However other design considerations, such as constraints on the flowpath area and limitations on the case construction, may make this option unattractive or unavailable. In circumstances where the endwall shock cannot be eliminated, it is desirable for the endwall shock to coincide with the passage shock since the aerodynamic penalty of coincident shocks is less than that of multiple individual shocks.

[0024] According to the present invention, coincidence of the endwall shock and the passage shock is achieved by uniquely shaping the airfoil so that the airfoil intercepts the endwall shock extending from the airfoil's leading neighbor and results in coincidence between the endwall shock and the passage shock.

[0025] One swept back airfoil according to the present invention has a leading edge 28, a trailing edge 30, a root 24 and a tip 26 located at a tip radius $r_{t\text{tip}}$. An inner transition point 40 located at an inner transition radius $r_{t\text{-inner}}$ is the axially forwardmost point on the leading edge. The leading edge of the airfoil is swept back by a radially varying first sweep angle σ_1 in an intermediate region 70 of the airfoil (in Figure 2 plane 56 appears as the line defined by the plane's intersection with the plane of the illustration and in Figure 3 the tangent line 54 appears as the point where the tangent line penetrates the plane of the Figure). The intermediate region 70 is the region radially bounded by the inner transition radius $r_{t\text{-inner}}$ and the outer transition radius $r_{t\text{-outer}}$. The first sweep angle, as is customary in the art, is nondecreasing with increasing radius, i.e. the sweep angle increases, or at least does not decrease, with increasing radius.

[0026] The leading edge 28 of the airfoil is also swept

back by a radially varying second sweep angle σ_2 in a tip region 74 of the airfoil. The tip region is radially bounded by the outer transition radius $r_{t\text{-outer}}$ and a tip radius r_{tip} . The second sweep angle is nonincreasing (decreases, or at least does not increase) with increasing radius. This is in sharp contrast to the prior art airfoil 22' whose sweep angle increases with increasing radius radially outward of the inner transition radius.

[0027] The beneficial effect of the invention is appreciated primarily by reference to Fig. 3 which compares the invention (and the associated endwall and passage shocks) to a prior art blade (and its associated shocks) shown in phantom. Referring first to the prior art illustration in phantom, the endwall shock 64 originates as a result of the pressure waves 60 (Fig. 1) extending along the suction surface of each blade. Each endwall shock is oblique to a plane 67 perpendicular to the rotational axis, and extends across the interblade passage of origin. The passage shock 66 also extends across the flow passage from the leading edge of a blade to the suction surface of the blade's leading neighbor. The working medium entering the passages is therefore adversely influenced by multiple shocks. By contrast, the nonincreasing character of the second sweep angle of a swept back airfoil 22 according to the invention causes a portion of the airfoil leading edge to be far enough forward (upstream) in the working medium flow that the section of the airfoil radially coextensive with the endwall shock extending from the airfoil's leading neighbor intercepts the endwall shock 64 (the unique sweep of the airfoil does not appreciably affect the location or orientation of the endwall shock; the phantom endwall shock 64' associated with the prior art blade is illustrated slightly up-stream of the endwall shock 64 for the airfoil of the invention merely for illustrative clarity). In addition, the passage shock 66 (which remains attached to the airfoil leading edge and therefore is translated forward along with the leading edge) is brought into coincidence with the endwall shock 64 so that the working medium does not encounter multiple shocks.

[0028] The embodiment of Figures 2 and 3 illustrates a blade whose leading edge, in comparison to the leading edge of a conventional blade, has been translated axially forward parallel to the rotational axis (the corresponding translation of the trailing edge is an illustrative convenience -- the location of the trailing edge is not embraced by the invention). However the invention contemplates any blade whose airfoil intercepts the endwall shock to bring the passage shock into coincidence with the endwall shock. For example, Figure 5 illustrates an embodiment where a section of the tip region is displaced circumferentially (relative to the prior art blade) so that the blade intercepts the endwall shock 64 and brings it into coincidence with the passage shock 66. As with the embodiment of Fig. 3, the displaced section extends radially inward far enough to intercept the endwall shock 64 over its entire radial extent and brings it into coincidence with the passage shock 66. This embodi-

ment functions as effectively as the embodiment of Figure 3 in terms of bringing the passage shock into coincidence with the endwall shock. However it suffers from the disadvantage that the airfoil tip is curled in the direction of rotation R. In the event that the blade tip contacts the rubstrip 46 during engine operation, the curled blade tip will gouge rather than abrade the rubstrip necessitating its replacement. Other alternative embodiments may also suffer from this or other disadvantages.

[0029] Referring to Fig 6 and 7, a forward swept airfoil 122 according to an arrangement which falls outside the scope of the present invention has a leading edge 128, a trailing edge 130, a root 124 and a tip 126 located at a tip radius r_{tip} . An inner transition point 140 located at an inner transition radius $r_{t\text{-inner}}$ is the axially aftmost point on the leading edge. The leading edge of the airfoil is swept forward by a radially varying first sweep angle σ_1 in an intermediate region 70 of the airfoil. The intermediate region is radially bounded by the inner transition radius $r_{t\text{-inner}}$ and the outer transition radius $r_{t\text{-outer}}$. The first sweep angle σ_1 is nondecreasing with increasing radius, i.e. the sweep angle increases, or at least does not decrease, with increasing radius.

[0030] The leading edge 128 of the airfoil is also swept forward by a radially varying second sweep angle σ_2 in a tip region 74 of the airfoil. The tip region is radially bounded by the outer transition radius $r_{t\text{-outer}}$ and the tip radius r_{tip} . The second sweep angle is nonincreasing (decreases, or at least does not increase) with increasing radius. This is in sharp contrast to the prior art airfoil 122' whose sweep angle increases with increasing radius radially outward of the inner transition radius.

[0031] In the forward swept arrangement, as in the swept back embodiment, the nonincreasing sweep angle σ_2 in the tip region 74 causes the endwall shock 64 to be coincident with the passage shock 66 for reducing the aerodynamic losses as discussed previously. This is in contrast to the prior art blade, shown in phantom where the endwall shock and the passage shock are distinct and therefore impose multiple aerodynamic losses on the working medium.

[0032] In the swept back embodiment of Fig. 2, the inner transition point is the axially forwardmost point on the leading edge. The leading edge is swept back at radii greater than the inner transition radius. The character of the leading edge sweep inward of the inner transition radius is not embraced by the invention.

50 Claims

1. A swept fan blade (22) for a gas turbine engine comprising a plurality of blades mounted for rotation within a case circumscribing the blades and forming an outer boundary for a working medium gas flowing through flow passages defined between neighbouring blades, wherein:

the blade has a configuration providing supersonic flow velocities in at least a portion of each passage when rotated in use thereby forming an endwall shock in the vicinity of the case; and the blade has a leading edge (28) with an inner region, an intermediate region (70) and a tip region (74); the inner region beginning at and extending inwardly from the inner boundary of the intermediate region (70), and the tip region (74) beginning at the outward boundary of the intermediate region (70) and extending to the tip (26) of the blade, **characterised in that:**

the inner region is swept forward;
the intermediate region (70) has a rearward sweep angle (σ_1) which is nondecreasing with increasing radius from the inward boundary to the outward boundary of the intermediate region (70);
the tip region (74) has a sweep angle (σ_2) which throughout the tip region (74) is nonincreasing with increasing radius, such that said blade intercepts said endwall shock.

2. A blade as claimed in claim 1, wherein the sweep angle (σ_1) in the intermediate region (70) increases throughout the intermediate region (70).
3. A blade as claimed in claim 1 or 2, wherein the sweep angle (σ_2) in the tip region (74) decreases throughout the tip region.
4. A blade as claimed in any preceding claim wherein the radially inner beginning of the intermediate region (70) is the axially foremost point of said leading edge (28).
5. A blade as claimed in any preceding claim wherein the tip region (74) is swept rearwardly.
6. A gas turbine engine comprising a blade as claimed in any preceding claim.

Patentansprüche

1. Gekrümmte Bläser-Laufschaukel (22) für eine Gasturbinenmaschine aufweisend eine Mehrzahl von Laufschaukeln, die rotationsfähig in einem Gehäuse angebracht sind, welches die Laufschaukeln umgibt und eine äußere Begrenzung für ein Arbeitsmediumgas bildet, welches durch Strömungspassagen strömt, die zwischen einander benachbarten Laufschaukeln definiert sind, wobei gilt:

die Laufschaukel besitzt eine Gestalt, welche Überschall-Strömungsgeschwindigkeiten in mindestens einem Teil einer jeden Passage lie-

fert, wenn es bei Verwendung in Rotation versetzt wird, und so einen Wandstoss in der Nähe des Gehäuses bildet;

und die Laufschaukel besitzt eine Vorderkante (28) mit einem inneren Bereich, mittleren Bereich (70) und einem Spitzenbereich (74); wobei der innere Bereich an der inneren Begrenzung des mittleren Bereiches (70) beginnt und sich von dort nach innen erstreckt, und der Spitzenbereich an der äußeren Begrenzung des mittleren Bereiches (70) beginnt und sich bis zur Spitze (26) der Laufschaukel erstreckt,

dadurch gekennzeichnet,

dass der innere Bereich nach vorne gekrümmt ist; dass der mittlere Bereich einen Rückwärts-Krümmungswinkel (σ_1) besitzt, der mit zunehmendem Radius von der inneren Begrenzung bis zur äußeren Begrenzung des mittleren Bereiches (70) nicht abnimmt; und

dass der Spitzenbereich (74) einen Krümmungswinkel (σ_2) besitzt, der über den Spitzenbereich (74) mit zunehmendem Radius nicht zunimmt, so daß die Laufschaukel den Wandstoss abfängt.

2. Laufschaukel nach Anspruch 1, bei der der Krümmungswinkel (σ_1) in dem mittleren Bereich (70) über den mittleren Bereich (70) zunimmt.
3. Laufschaukel nach Anspruch 1 oder 2, bei der der Krümmungswinkel (σ_2) in dem Spitzenbereich (74) über den Spitzenbereich abnimmt.
4. Laufschaukel nach einem der vorangehenden Ansprüche, bei der der radial innere Anfang des mittleren Bereiches (70) der axial vorderste Punkt der Vorderkante (28) ist.
5. Laufschaukel nach einem der vorangehenden Ansprüche, bei der der Spitzenbereich nach hinten gekrümmt ist.
6. Gasturbinenmaschine aufweisend eine Laufschaukel nach einem der vorangehenden Ansprüche.

Revendications

1. Pale de ventilation en flèche (22) pour turbomoteur, comprenant une pluralité de pales montées pour tourner à l'intérieur d'un boîtier entourant les pales et formant une limite externe pour un gaz formant fluide moteur circulant à travers des passages d'écoulement définis entre des pales voisines, dans laquelle :

la pale présente une configuration offrant des vitesses d'écoulement supersoniques dans au

moins une partie de chaque passage lorsqu'elle tourne en service formant ainsi un choc de paroi d'extrémité dans le voisinage du boîtier ;
et

la pale présente un bord d'attaque (28) avec une région intérieure, une région intermédiaire (70) et une région de pointe (74) ; la région intérieure commençant à et s'étendant intérieurement depuis la limite interne de la région intermédiaire (70), et la région en pointe (74) commençant à la limite externe de la région intermédiaire (70) et s'étendant jusqu'à la pointe (26) de la pale, **caractérisée en ce que** :

la région interne est en flèche vers l'avant ;
la région intermédiaire (70) comporte un angle de flèche (σ_1) vers l'arrière, qui ne décroît pas avec un rayon croissant depuis la limite interne à la limite externe de la région intermédiaire (70) ;
la région en pointe (74) comporte un angle de flèche (σ_2) qui sur toute la région de pointe (74) n'est pas croissant avec un rayon croissant, de telle sorte que ladite pale intercepte ledit choc de paroi d'extrémité.

2. Pale selon la revendication 1, dans laquelle l'angle de flèche (σ_1) dans la région intermédiaire (70) augmente sur toute la région intermédiaire (70).
3. pale selon la revendication 1 ou 2, dans laquelle l'angle de flèche (σ_2) dans la région de pointe (74) décroît sur toute la région de pointe.
4. Pale selon l'une quelconque des revendications précédentes, dans laquelle le début radial intérieur de la région intermédiaire (70) est le point le plus avancé axialement dudit bord d'attaque (28).
5. Pale selon l'une quelconque des revendications précédentes, dans laquelle la région de pointe (74) est en flèche vers l'arrière.
6. Turbomoteur comprenant une pale selon l'une quelconque des revendications précédentes.

50

55

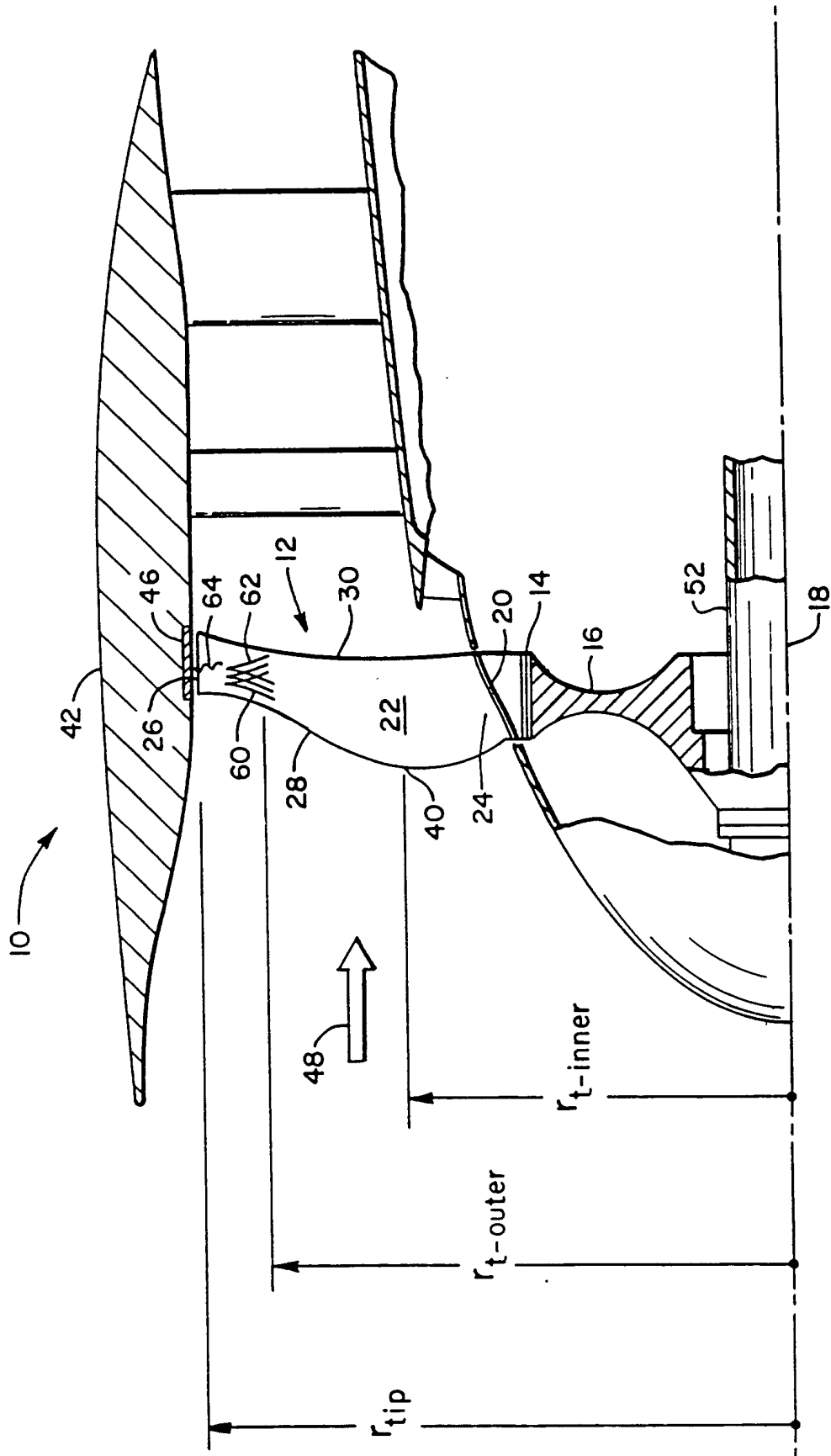
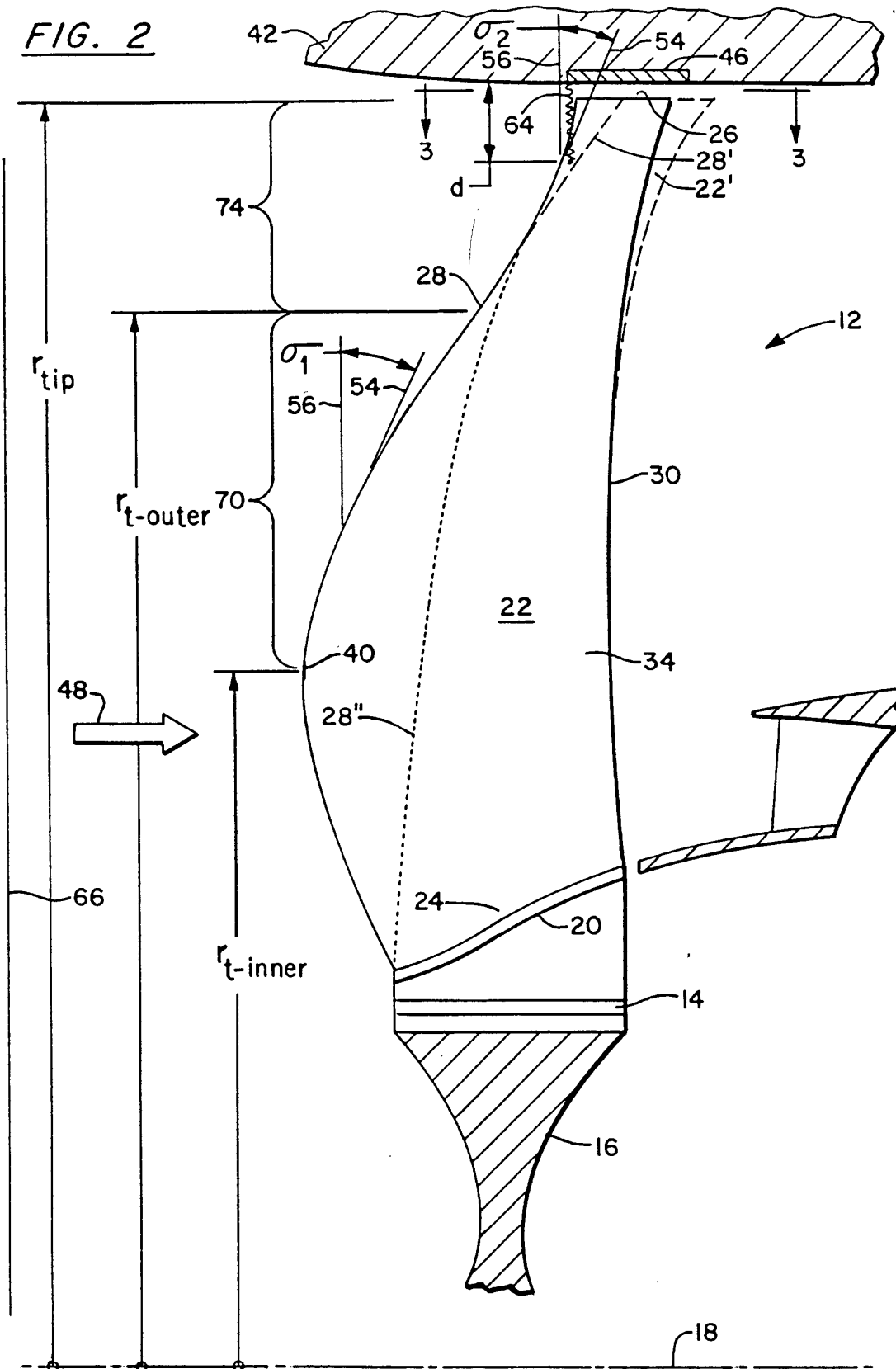

FIG. 1

FIG. 2



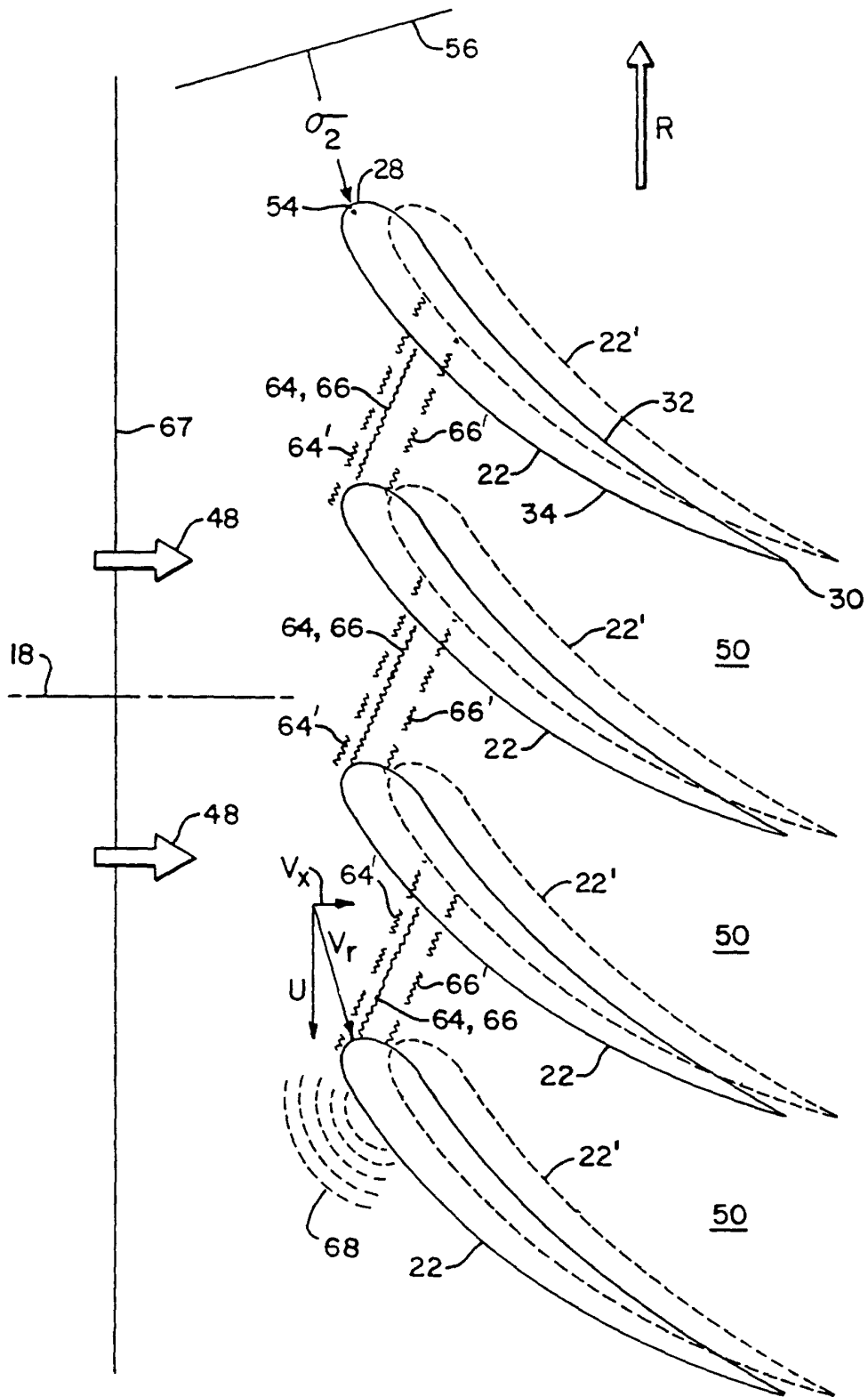

FIG. 3

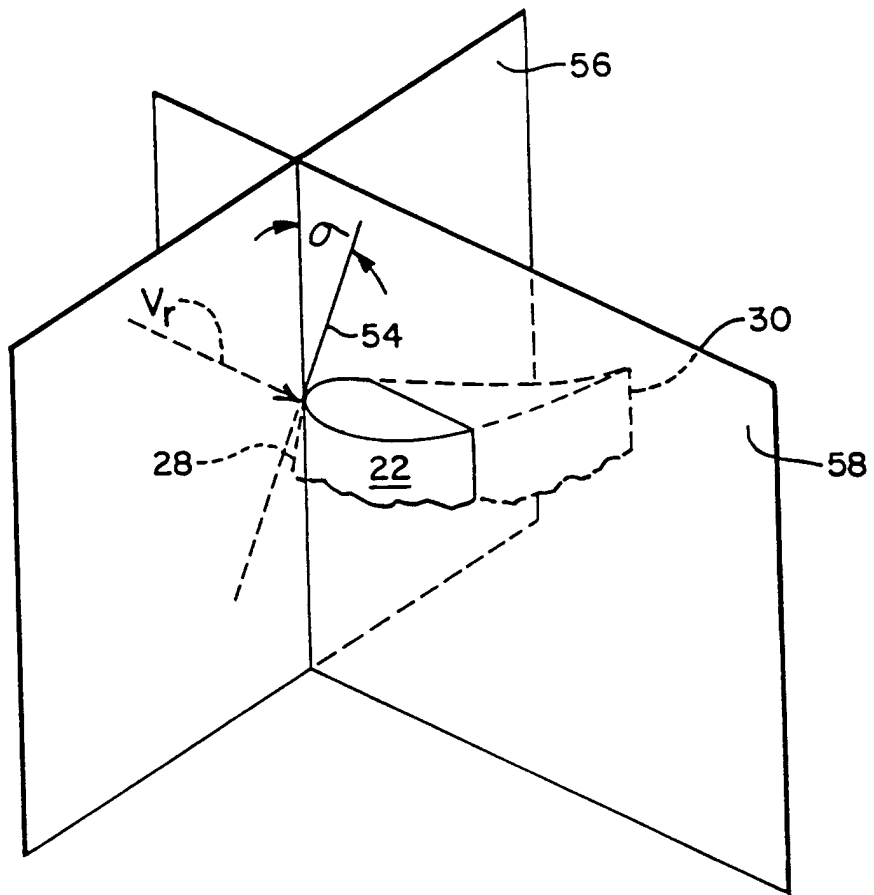

FIG. 4

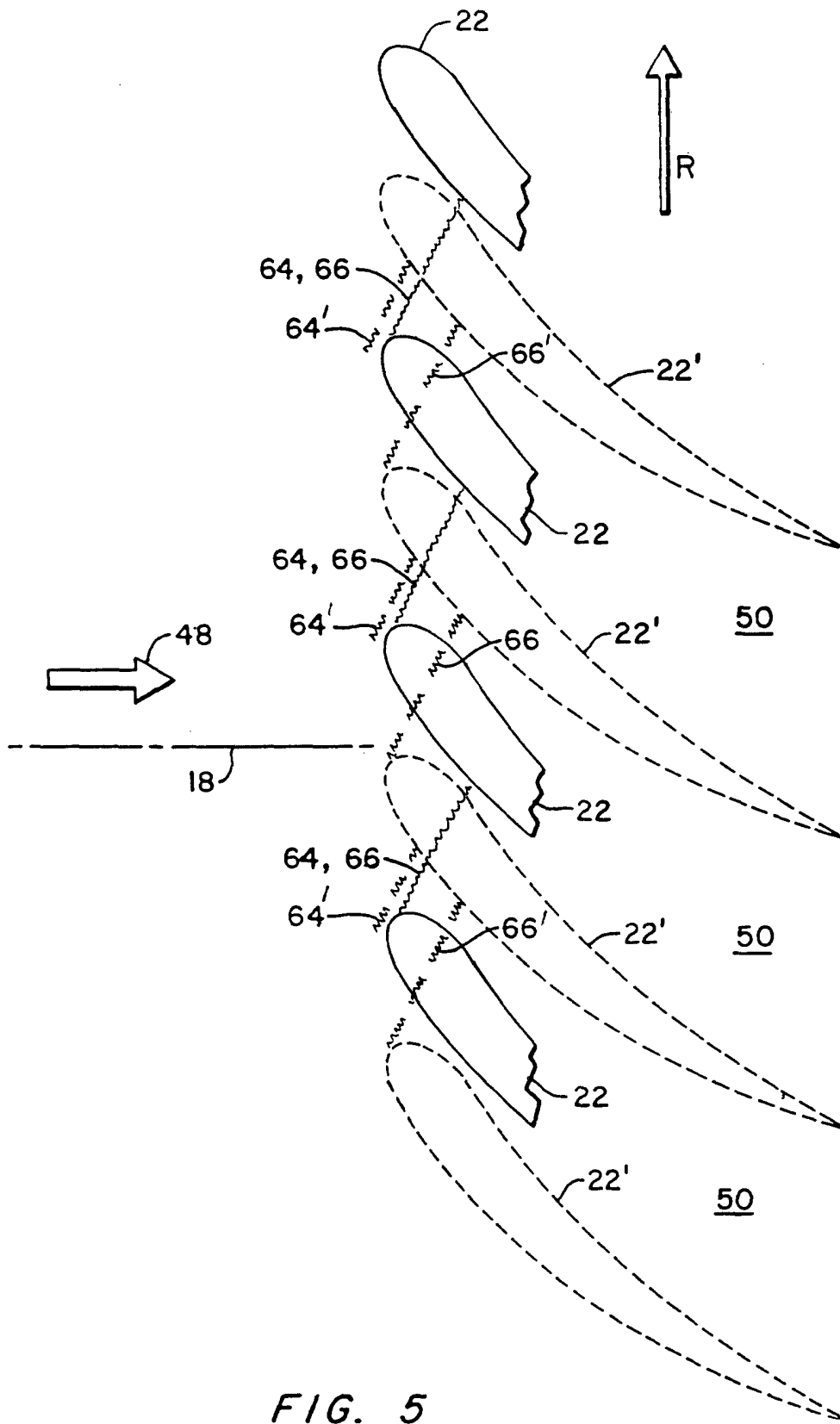
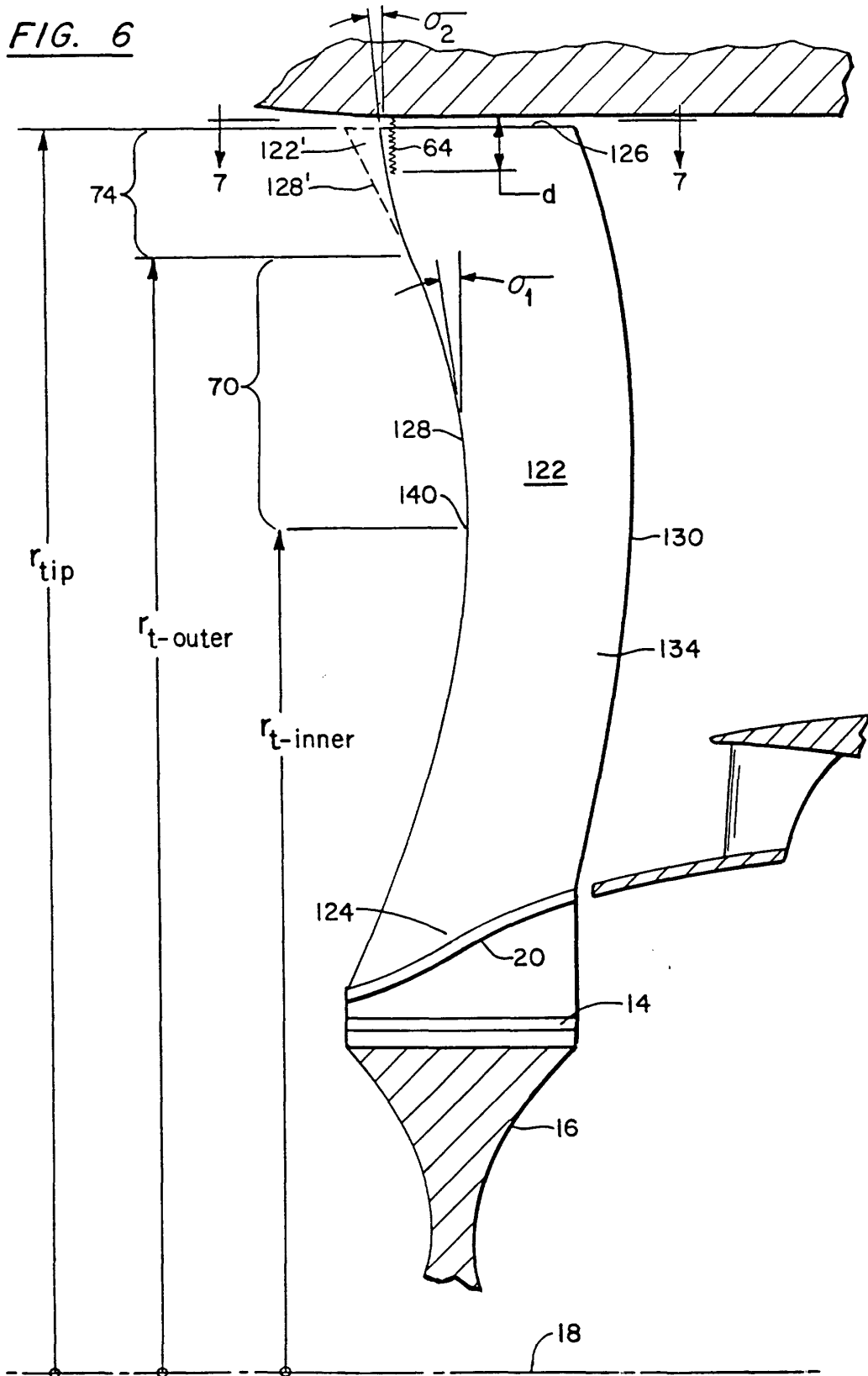

FIG. 5

FIG. 6



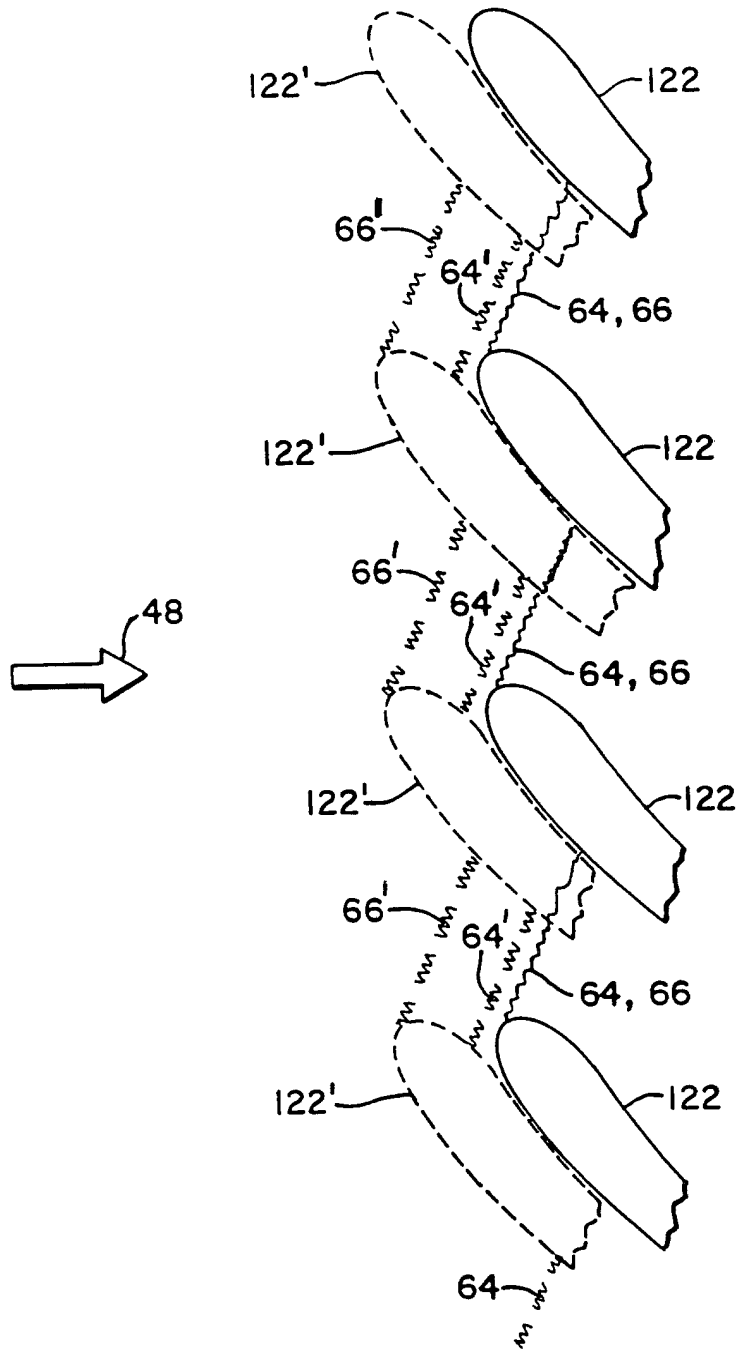

FIG. 7