



US00RE36314E

**United States Patent** [19]  
**Yamazaki et al.**

[11] E **Patent Number: Re. 36,314**  
[45] **Reissued Date of Patent: Sep. 28, 1999**

- [54] **INSULATED GATE FIELD EFFECT SEMICONDUCTOR DEVICES HAVING A LDD REGION AND AN ANODIC OXIDE FILM OF A GATE ELECTRODE**
- |           |         |                |          |
|-----------|---------|----------------|----------|
| 4,468,855 | 9/1984  | Sasaki         | 29/576 B |
| 4,557,036 | 12/1985 | Kyuragi et al. | 257/412  |
| 4,646,426 | 3/1987  | Sasaki         | 29/571   |
- (List continued on next page.)

- [75] Inventors: **Shunpei Yamazaki**, Tokyo; **Hongyong Zhang**, Kanagawa; **Yasuhiko Takemura**, Shiga, all of Japan
- [73] Assignee: **Semiconductor Energy Laboratory Co., Ltd.**, Kanagawa-ken, Japan

**FOREIGN PATENT DOCUMENTS**

0072216	2/1983	European Pat. Off.	437/907
5881972	7/1981	Japan	257/66
5832466	2/1983	Japan	437/187
58-95814	6/1983	Japan	257/66
58-115864	7/1983	Japan	257/66
58-124273	7/1983	Japan	257/66
58-158967	9/1983	Japan	257/66
59-214262	12/1984	Japan	437/197
62-124769	6/1987	Japan	257/59
3-334433	2/1991	Japan	437/907

- [21] Appl. No.: **08/620,857**
- [22] Filed: **Jun. 4, 1996**

**Related U.S. Patent Documents**

- Reissue of:
- [64] Patent No.: **5,308,998**  
Issued: **May 3, 1994**  
Appl. No.: **07/933,810**  
Filed: **Aug. 24, 1992**
- U.S. Applications:

**OTHER PUBLICATIONS**

- Ghandhi, S., "VLSI Fabrication Principles," John Wiley & Sons, New York, 1983, pp. 401-411.
- Patent Abstracts of Japan, Section E, Section No. 1060, vol. 15, No. 161, p. 128 (Apr. 23, 1991).
- Wolf et al., Silicon Processing, Lattice Press, vol. 1, 1986, pp. 151-154.
- Wolf, Silicon Processing, Lattice Press, 1990, vol. 2, pp. 66-72.

- [63] Continuation-in-part of application No. 07/846,164, Mar. 5, 1992, Pat. No. 5,289,030.

**Foreign Application Priority Data**

- |               |      |       |          |
|---------------|------|-------|----------|
| Aug. 26, 1991 | [JP] | Japan | 3-238713 |
| Jan. 21, 1992 | [JP] | Japan | 4-30220  |

- [51] **Int. Cl.<sup>6</sup>** ..... **H01L 29/04**; H01L 31/036; H01L 27/01; H01L 29/76
- [52] **U.S. Cl.** ..... **257/57**; 257/66; 257/351; 257/408; 257/410
- [58] **Field of Search** ..... 257/66, 57, 63, 257/410, 411, 412, 336, 344, 408, 59, 64, 72, 347, 350, 351, 369; 437/42, 907

*Primary Examiner*—Steven H. Loke  
*Attorney, Agent, or Firm*—Sixbey, Friedman, Leedom & Ferguson, PC; Eric J. Robinson

**ABSTRACT**

[57] An IGFET has differential crystallinity in offset regions near the source-channel and drain-channel boundaries. In one embodiment, an offset region with crystallinity different from that of an adjacent region is provided between the channel and at least one of the source and drain regions. An oxide film may be provided to cover the surface of the gate electrode, formed by anodizing the surface of the gate electrode, and this layer may be used as a mask when forming the crystallinity offset regions.

[56] **References Cited**

**U.S. PATENT DOCUMENTS**

- |           |         |               |         |
|-----------|---------|---------------|---------|
| 3,775,262 | 11/1973 | Heyerdahl     | 257/411 |
| 4,455,737 | 6/1984  | Godejahn, Jr. | 29/571  |

**11 Claims, 10 Drawing Sheets**

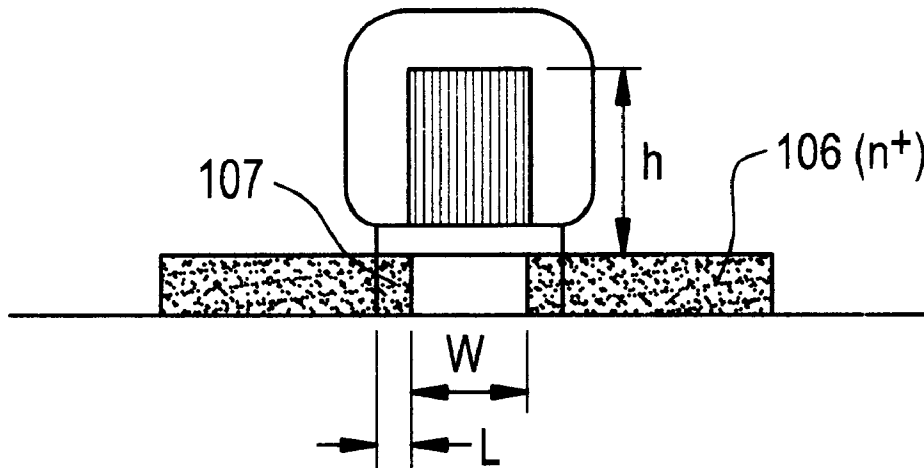

U.S. PATENT DOCUMENTS

4,727,044	2/1988	Yamazaki .....	437/45	5,112,764	5/1992	Mitra et al. ....	437/44
4,746,628	5/1988	Takafuji et al. ....	437/187	5,126,283	6/1992	Pintchovski et al. ....	437/188
4,769,337	9/1988	Ovshinsky et al. ....	437/39	5,134,093	7/1992	Onishi et al. ....	437/197
4,822,751	4/1989	Ishizu et al. ....	437/173	5,142,344	8/1992	Yamazaki et al. ....	257/66
4,868,137	9/1989	Kubota .....	437/41	5,165,075	11/1992	Hiroki et al. ....	359/59
4,900,695	2/1990	Takahashi et al. ....	437/195	5,258,319	11/1993	Inuishi et al. ....	437/35
4,905,066	2/1990	Dohjo et al. ....	257/412	5,272,361	12/1993	Yamazaki .....	257/66
5,097,311	3/1992	Iwase et al. ....	257/412	5,289,030	2/1994	Yamazaki et al. ....	257/410
				5,306,651	4/1994	Masumo et al. ....	437/40

FIG. 1A

PRIOR ART

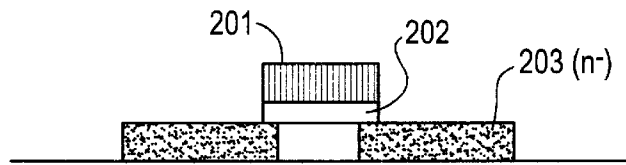

FIG. 1B

PRIOR ART

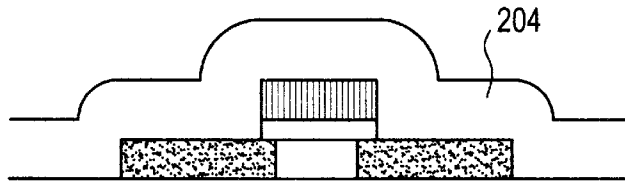

FIG. 1C

PRIOR ART

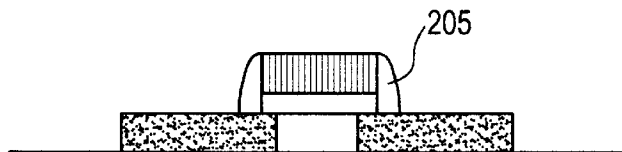

FIG. 1D

PRIOR ART

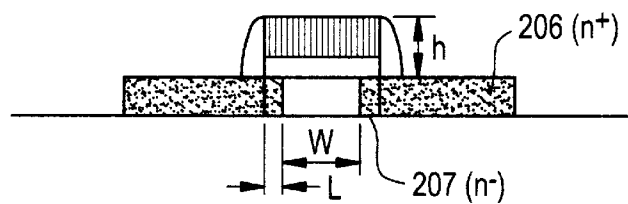

FIG. 2A

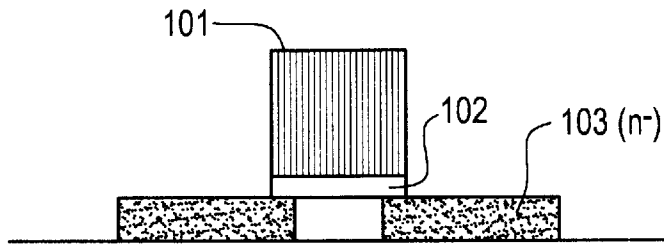

FIG. 2B

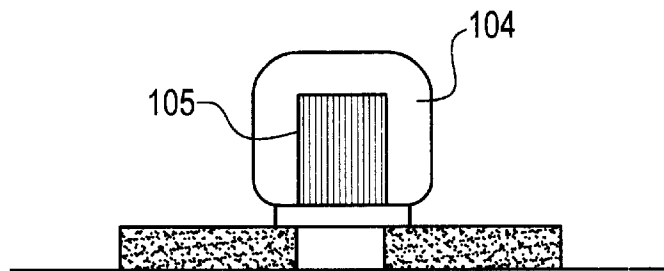

FIG. 2C

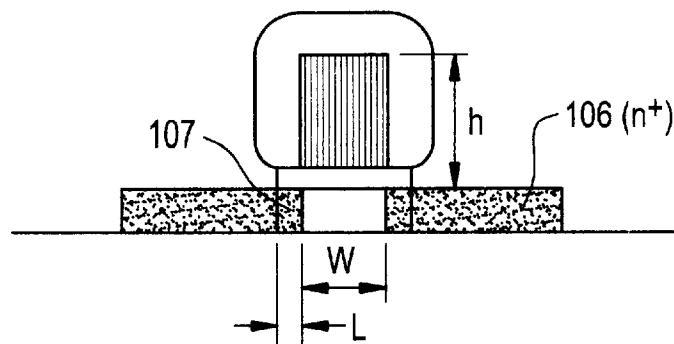

FIG. 3A

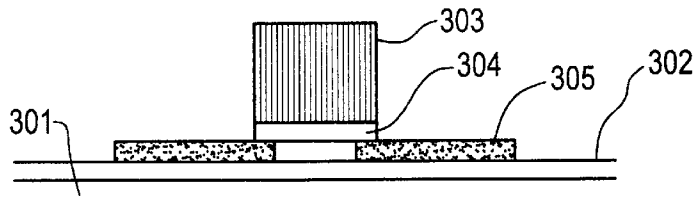

FIG. 3B

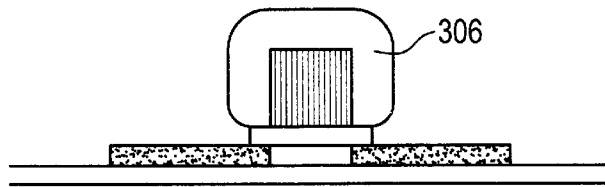

FIG. 3C

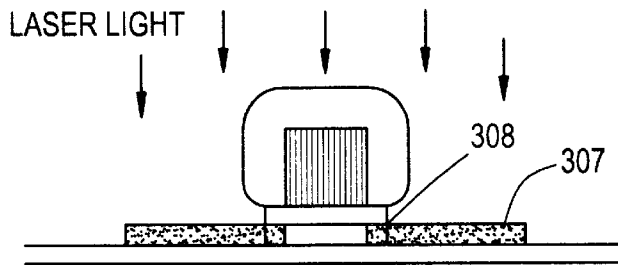

FIG. 3D

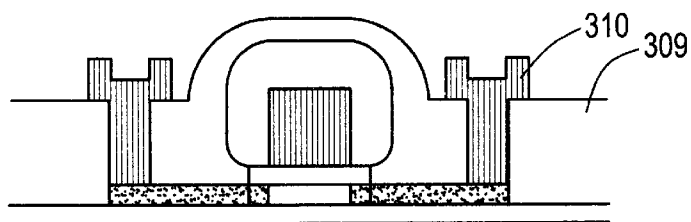

FIG. 4A

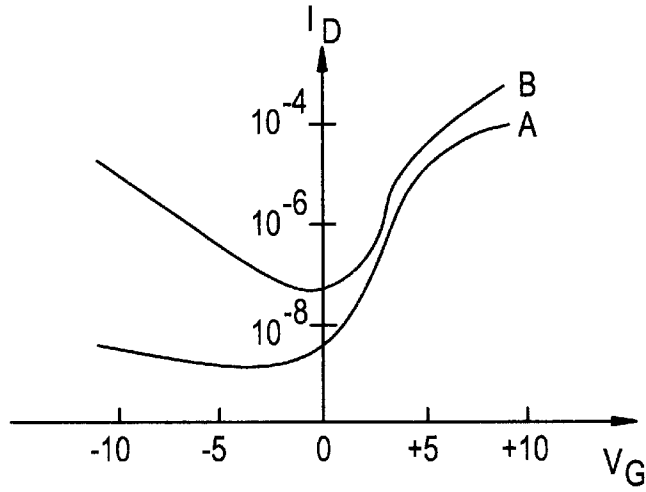

FIG. 4B



FIG. 4D



FIG. 4C

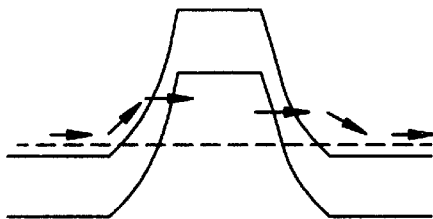

FIG. 4E

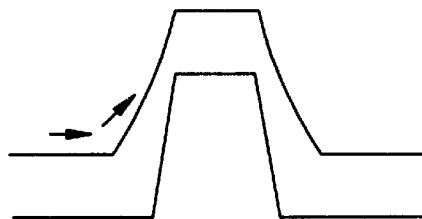

FIG. 5A

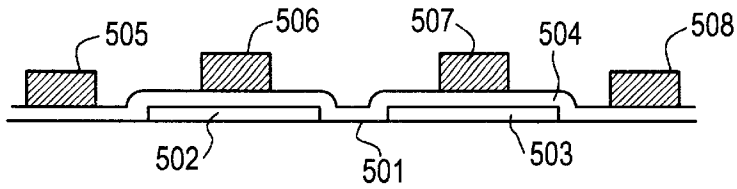

FIG. 5B

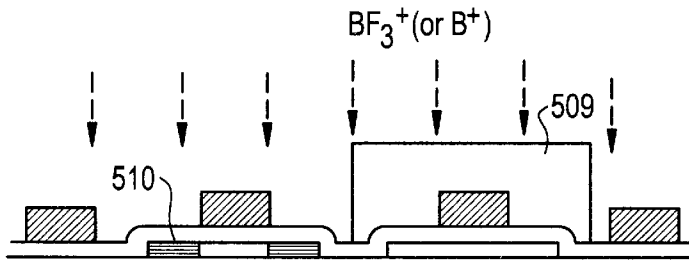

FIG. 5C

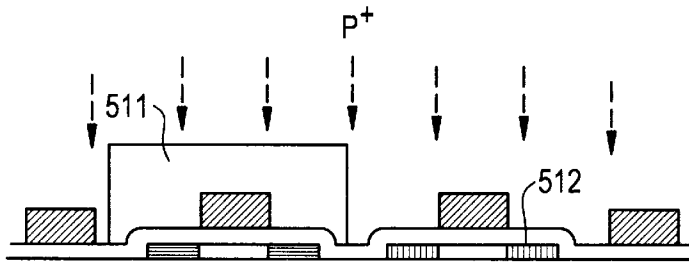

FIG. 5D

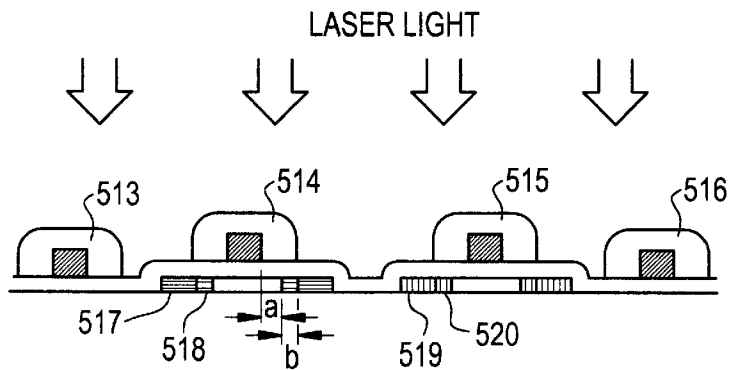

FIG. 5E

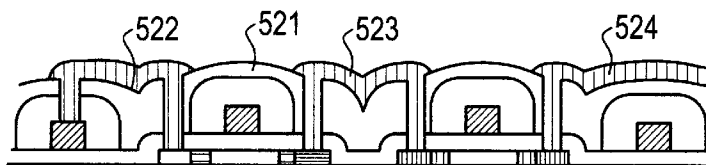

FIG. 6A

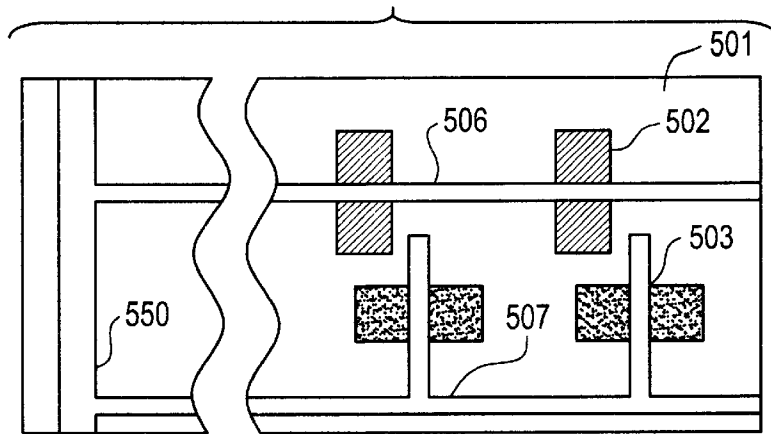

FIG. 6B

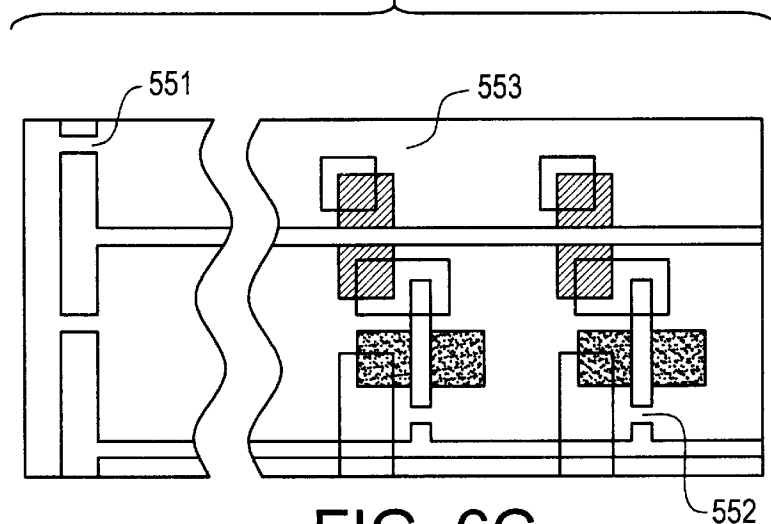

FIG. 6C

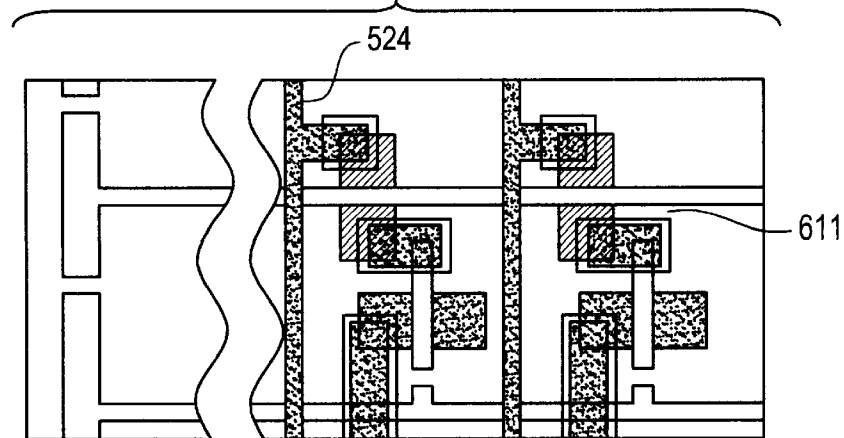



FIG. 7A

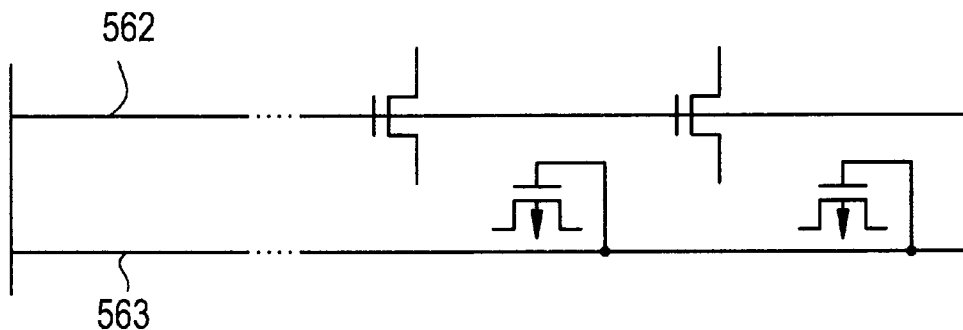

FIG. 7B

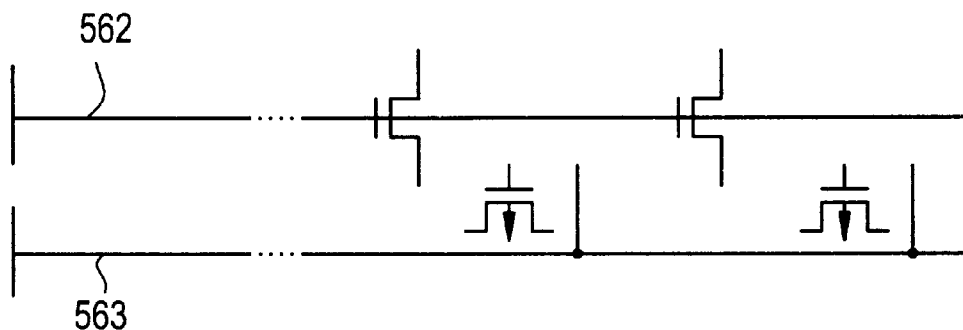

FIG. 7C

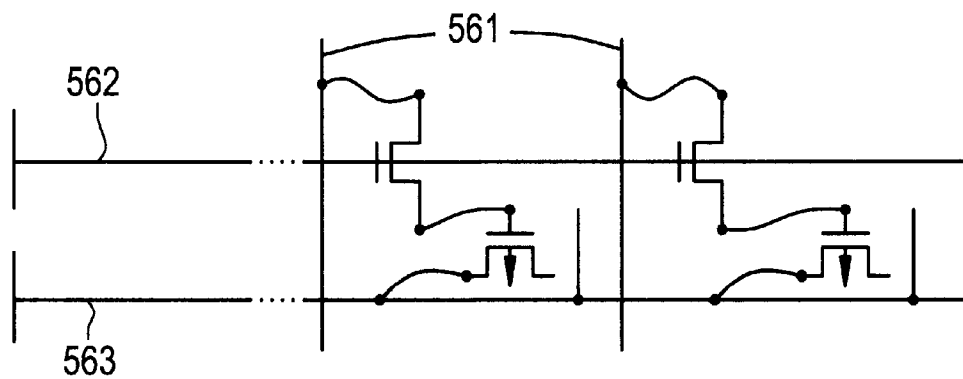

FIG. 8A

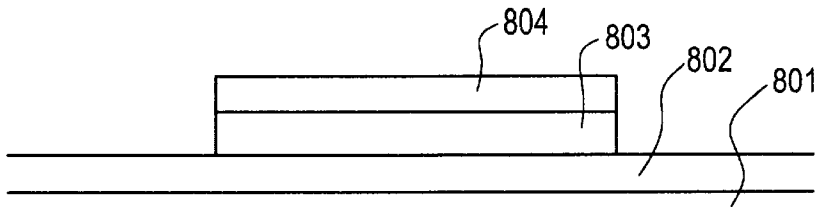

FIG. 8B

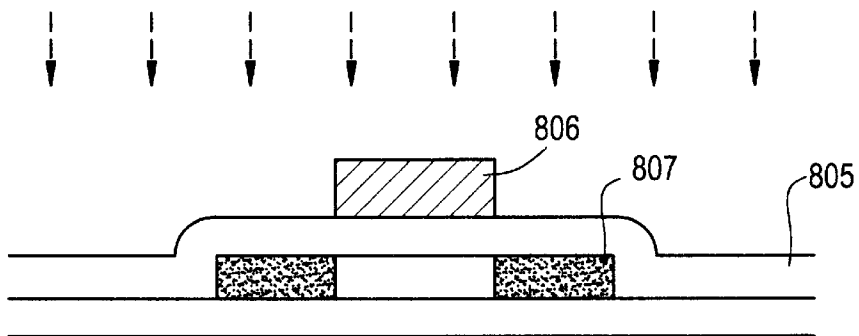

FIG. 8C

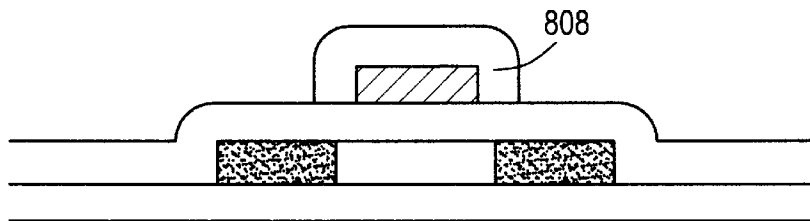

FIG. 8D

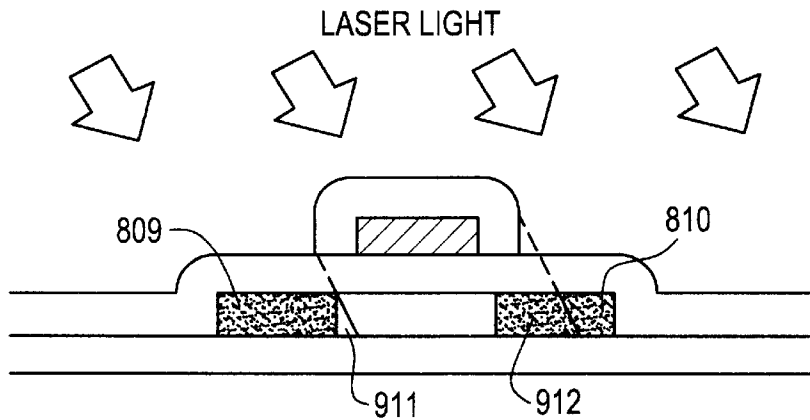

FIG. 9A

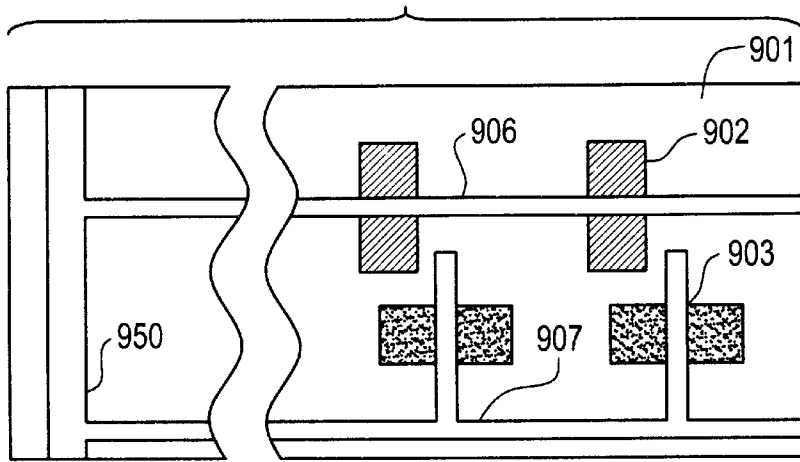

FIG. 9B

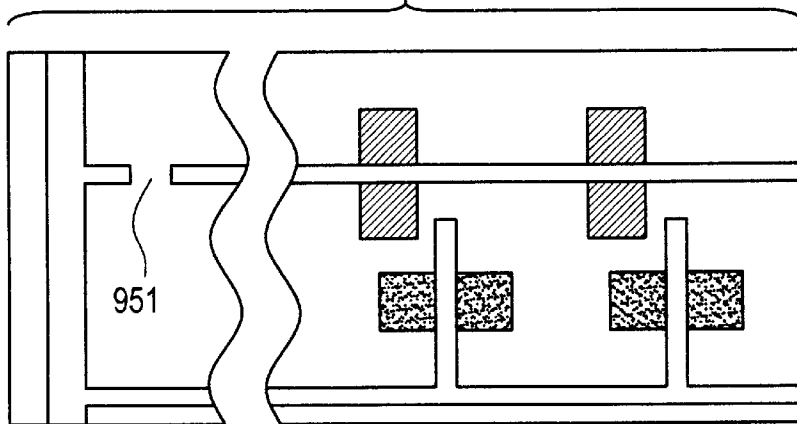

FIG. 9C

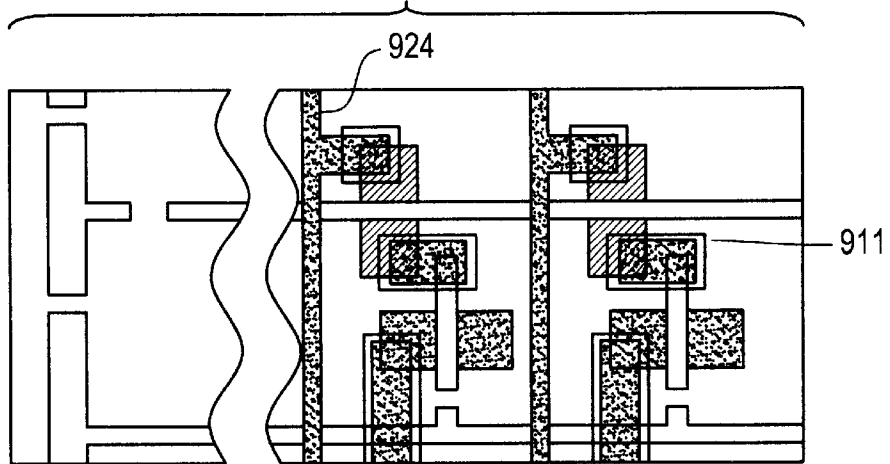

FIG. 10A

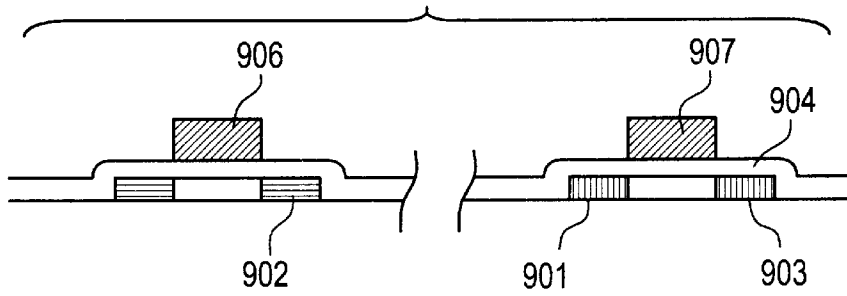

FIG. 10B

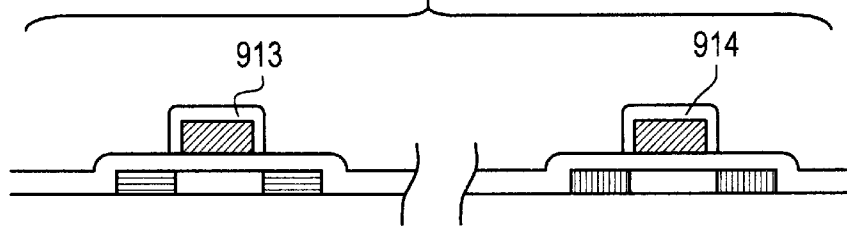

FIG. 10C

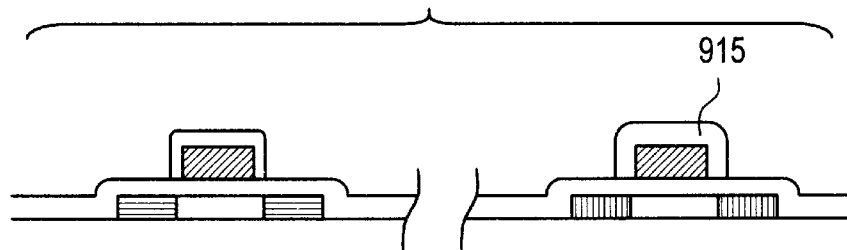
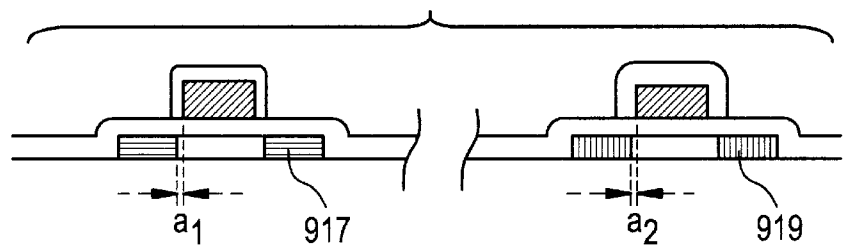

FIG. 10D



**INSULATED GATE FIELD EFFECT  
SEMICONDUCTOR DEVICES HAVING A  
LDD REGION AND AN ANODIC OXIDE  
FILM OF A GATE ELECTRODE**

**Matter enclosed in heavy brackets [ ] appears in the original patent but forms no part of this reissue specification; matter printed in italics indicates the additions made by reissue.**

*This application is a continuation-in-part of Ser. No. 846,164, filed Mar. 5, 1992, now U.S. Pat. No. 5,289,030.*

**BACKGROUND OF THE INVENTION**

**1. Field of the Invention**

The present invention relates in general to an insulated gate field effect semiconductor device and method of manufacturing the same.

**2. Description of the Prior Art**

A variety of approaches have been carried out in order to miniaturize integrated circuits and achieve a higher packing density in a chip. Particularly, remarkable advances have been reported in the development of the technology to miniaturize insulated gate field effect semiconductor devices, denoted as MOSFET for short. MOS is the acronym of Metal Oxide Semiconductor. The metal used in MOSFETs generally includes, in addition to genuine metals, conductive materials such as semiconductors having a sufficient conductivity, alloys composed of semiconductor(s) and/or metal(s). The oxide generally includes, in addition to genuine oxides, insulating materials having a sufficient resistivity such as nitrides. Although these materials do exactly not correspond to the acronym MOS, the term MOSFET is used in the broad sense in this description.

The miniaturizing of MOSFETs is realized by decreasing the width of the gate electrode. The decrease of the width of the gate electrode leads to the decrease of the channel length underlying the gate electrode. This also results in a high operational speed because the short channel length decreases the time required for carriers to pass across the channel.

The miniaturizing, on the other hand, gives rise to other problems, i.e. short channel effects. One of the most serious problems thereof is hot electron effects. In the structure comprising highly doped source and drain regions with an inversely doped intervening channel region therebetween, the strength of the electric field at the boundary between the channel region and the highly doped region increases as the channel length decreases. As a result, the characteristics of the device are unstable.

The LDD (lightly-doped-drain) structure has been proposed to solve the above problem. This structure is schematically illustrated in FIG. 1(D). In the figure, reference numeral 207 designates a lightly doped region formed inside of a highly doped region 206. The region 207 is called a LDD region. By provision of such a LDD region, the strength of the electric field in the vicinity of the boundary between the channel region and the drain region is decreased so that the operation of the device becomes more stable.

FIGS. 1(A) to 1(D) are cross sectional views showing a method of making a conventional MOSFET. Although an n-channel transistor is explained here, a p-channel transistor is formed in the same manner only by inverting the conductivity type. A semiconductor film is deposited onto an insulating substrate and patterned in order to define a semiconductor active region. An oxide film and a conductive

film are deposited on the semiconductor film and patterned by etching in order to form a gate electrode 201 insulated by a gate insulating film 202. With the gate electrode 201 and the insulating film 202 as a mask, lightly doped regions 203 are formed by ion implantation in a self-aligning manner.

Next, the structure is coated with an insulating film 204 such as a PSG film. The insulating film 204 is removed by an anisotropic etching (directional etching) leaving spacers 205 flanking the gate electrode 201. With the spacers 205 as a mask, heavily doped regions 206 are formed to provide source and drain regions. By employing this LDD design, the channel length can be decreased to as short as 0.1 micrometer while the channel length in usual designs can not be decreased to 0.5 micrometer or shorter.

The problems associated with the short channel designs, however, are not completely solved by this technique. Another problem is the resistance of the gate electrode which has become narrow. Even if the switching speed of the device is increased by the short channel, the speed-up may possibly come to naught due to propagation delay along the high resistant gate electrode. The resistance of the gate electrode can be decreased to some extent by employing a metal silicide having a low resistivity in place of polysilicon to form the gate electrode or by providing a low resistant line such as an aluminum line extending along the gate electrode. These techniques, however, can not solve the high resistance problem when the width of the gate electrode is no larger than 0.3 micrometer.

Another approach to solve the problem is to increase the aspect ratio of the gate electrode, i.e. the ratio of the height to the width of the gate electrode. The resistance of the gate electrode decreases in proportion to the cross sectional area which increases as the aspect ratio increases. From the view point of manufacture restraints, the aspect ratio can not be increased so much. This is mainly because the width of the spacers depend on the height of the gate electrode. The spacer is formed with its width of 20% or wider of the height of the gate electrode. Accordingly if 0.1 micrometer length L (FIG. 1(D)) is desired, the height of the gate electrode can not exceed 0.5 micrometer. If the gate electrode has a height exceeding 0.5 micrometer, the length L exceeds 0.1 micrometer resulting in a higher resistance between the source and drain regions.

In the case of 0.5 micrometer height (h), 1.0 micrometer length (W) and 0.1 micrometer width (L) in FIG. 1(D), if the width (W) of the gate electrode is desired to be decreased to 0.5 micrometer, the height of the electrode must be increase to 1.0 micrometer in order to avoid increase of the gate resistance. The width of the spacers, however, becomes 0.2 micrometer so that the resistance between the source and drain regions is doubled. The halved channel length is expected to improve double the operational speed. The increase of double the source and drain resistance, however, cancels the improvement. Accordingly, the operational speed remains same as achieved before the shrinkage in size.

Usually, the width of the spacer becomes as wide as 50% to 100% of the height of the gate electrode, which width provides a further severe condition. The aspect ratios of the gate electrodes, therefore, have been no higher than 1, or in many cases no higher than 0.2 in accordance with the conventional LDD technique. In addition to this, the width of the spacer has been substantially dispersed, due to expected variations of production, which results in dispersed characteristics of the products. The conventional LDD technique has brought high integrations and high speeds and, on the contrary, impeded further improvement.

On the other hand, recently, semiconductor integrated circuits have been formed within semiconductor thin films

deposited on insulating substrates such as glass substrates (e.g., in the case of liquid crystal displays and image sensors) or on single crystal semiconductor substrates coated with insulating films (e.g., in the case of three-dimensional ICs). The LDD technique is often effective also in these cases. Because of disparity of thickness of one PSG film formed over a large glass substrate, the sizes of spacers become different depending upon the positions of the substrate.

In the case of LDD designs to be formed on an insulating surface for three-dimensional ICs, if there have been formed other circuits under the surface, the surface is usually not even so that the sizes of spacers are substantially dispersed. The yield of the conventional productions of three-dimensional ICs has therefore been low with dispersed characteristics.

#### BRIEF SUMMARY OF THE INVENTION

It is an object of the present invention to provide a method of manufacturing an insulated gate field effect semiconductor device within a small area which has a high switching speed and a low on-state resistance.

It is another object of the present invention to provide a method of manufacturing an insulated gate field effect semiconductor device having LDD regions which are short as compared with the height of the gate electrode.

It is a further object of the present invention to provide an insulated gate field effect semiconductor device having a new structure equivalent to LDD regions.

Additional objects, advantages and novel features of the present invention will be set forth in the description which follows, and in part will become apparent to those skilled in the art upon examination of the following or may be learned by practice of the present invention. The object and advantages of the invention may be realized and attained by means of the instrumentalities and combinations particularly pointed out in the appended claims.

To achieve the foregoing and other object, and in accordance with the present invention, as embodied and broadly described herein, an insulated gate field effect semiconductor device is manufactured by the steps of forming a conductive pattern on a semiconductor substrate through a gate insulating film, introducing an impurity into the semiconductor substrate with the conductive pattern as a mask, oxidizing an external surface of the conductive pattern to leave a gate electrode therein, and introducing an impurity into the semiconductor substrate with the oxidized conductive pattern as a mask.

The oxidation of the external surface of the conductive pattern can be carried out by anodic oxidation, a plasma oxidation (vapor phase oxidation) or a liquid phase oxidation. A bias voltage is applied to the conductive pattern or a lead connected thereto in the plasma oxidation or the liquid phase oxidation.

The present invention will be briefly explained with reference to FIGS. 2(A) to 2(C). Although an n-channel transistor is explained here, a p-channel transistor is formed in the same manner. A p-type silicon semiconductor thin film is deposited onto an insulating substrate and patterned in order to define a semiconductor active region. An oxide film and a conductive film are deposited on the semiconductor film and patterned by etching in order to form a conductive film **101** insulated by a gate insulating film **102** as illustrated in FIG. 2(A). The conductive film is made of, for example, titanium (Ti), aluminum (Al), tantalum (Ta), chromium (Cr) or an alloy consisting of two or more of these metals. With

the gate electrode **101** and the insulating film **102** as a mask, lightly doped regions **103** are formed by ion implantation in a self-aligning manner. The doping concentration of the regions **103** is  $1 \times 10^{17}$  to  $5 \times 10^{18} \text{ cm}^{-3}$ .

Next, the upper and side surfaces of the conductive film **101** are anodic oxidized to form a gate electrode **105** and an insulating oxide film **104** as illustrated in FIG. 2(B). The size of the gate electrode **105** is smaller than the size of the conductive film **101** because the surface portion of the film **101** is eaten by the oxidation to form the oxide film **104**. Thickness of the oxide film **104** is preferably 200 to 3500 Å, more preferably 1000 to 2500 Å. The spacial relationship between the gate electrode **105** and the lightly doped regions **103** is very important. If there is a substantial area of the channel region which is not covered by the overlying gate electrode, the channel region might not form a sufficiently effective channel therein when the gate electrode is given a signal. On the contrary, if the gate electrode overlaps the lightly doped regions **103** too much, a substantial parasitic capacitance is formed resulting in a slow switching speed.

It is, however, not so difficult in accordance with the present invention to control the relationship. The spread of the dopant within the lightly doped regions **103** due to secondary scattering of the ion implantation can be controlled by adjusting the acceleration energy of ions. The shrinkage of the conductive film **101** due to the anodic oxidation is also controlled by adjusting the thickness of the oxide film, i.e. by adjusting the oxidation condition. The thickness of the oxide film **104** can be controlled within  $\pm 10$  nm from a target thickness. The secondary scattering can be controlled at the same order accuracy. Namely, by accurately designing the respective dimensions, the optimum relationship between the lightly doped regions **103** and the gate electrode **105** can be achieved only with an error as small as 10 nm.

With the oxide film **104** as a mask, heavily doped regions **106** are formed by ion implantation to provide source and drain regions in accordance with self-aligning configuration as illustrated in FIG. 2(C). The doping concentration of the heavily doped regions **106** is  $1 \times 10^{20}$  to  $5 \times 10^{21} \text{ cm}^{-3}$ . The inner portions of the lightly doped regions **103** is left as LDD structures **107** having same configuration and same function as a conventional LDD structure. The length L of the LDD regions is, however, determined by the thickness of the oxide film **104** but independent of the height of the gate electrode so that the aspect ratio of the gate electrode can be increased to exceed 1.

In accordance with the present invention, the length L of the LDD regions can be arbitrarily and finely adjusted from 10 nm to 0.1 micrometer. The overlapping dimension between the gate electrode **105** the LDD regions **107** can be controlled at a similar accuracy as explained above. The channel length W can be reduced to 0.5 micrometer or less in this case. Conventionally, it had been very difficult to form a LDD region having 100 nm or less length and the error had been usually 20% or thereabout. It becomes, however, possible to form LDD regions having 10 to 100 nm lengths only with errors of about 10%.

Furthermore, in accordance with the present invention, the process is simplified because an insulating film need not be formed over the gate electrode in order to form spacers. The oxide film **104** formed by anodic oxidation is extremely uniform over the gate electrode and has a high resistivity. The formation of the oxide film can be carried out in the same manner wherever it is located on an uneven substrate.

The LDD structure **107** illustrated in FIG. 2(C) is same as that of the prior art LDD technique. A similar function can

be realized by utilizing noncrystalline semiconductors such as amorphous or semiamorphous semiconductors. In such a case, the LDD regions **107** are composed of a noncrystal semiconductor material doped with an impurity while the heavily doped regions **106** are composed of an usual single crystalline or polycrystalline impurity semiconductor. The LDD regions and the heavily doped region may have the same doping concentration in this case. An appropriate terminator such as hydrogen or a halogen has to be introduced into the noncrystal semiconductor material in order to terminate dangling bonds occurring in the material. FIG. **3(D)** illustrates an example of a MOSFET having such a LDD structure. The inventor discovered that this new type device utilizing a noncrystal semiconductor material exhibited improvement of characteristics of TFTs in the same manner as conventional LDD devices.

FIG. **4(A)** is a graph showing the relationship between the gate voltage  $V_g$  and the drain current  $I_d$ . Curve A is plotted in the case of the new type MOSFET device utilizing a noncrystal semiconductor. Curve B is plotted in the case of a conventional FET device with no LDD structure. In the case of the conventional device, the drain current increases also when  $-V_g$  increases. This undesirable characteristic is called reverse current leakage. When complementary FETs are formed, this is serious problem.

Contrary to this, the characteristic is improved by forming the noncrystal semiconductor regions as seen from curve A. The mechanism of the improvement has not certainly been understood yet. One assumption is thought that the effective doping concentration of the noncrystal region is lower than the actual doping concentration because the ionization rate in the noncrystal region is lower than that in the crystal region. For example, the ionization rate of amorphous silicon is 0.1 to 10% while that of single crystalline or polycrystalline silicon is approximately 100%.

Another assumption is based upon difference between the noncrystal and the crystal in band-gap. FIG. **4(B)** illustrates the energy band structure of a semiconductor device with a LDD structure when no gate signal is supplied. FIG. **4(C)** illustrates the energy band structure of a semiconductor device with a LDD structure when a large gate voltage is supplied in the reverse direction. In this case, small carrier leakage takes place through the device due to tunnel effects and hopping among trapping levels existing in the band-gap. The provision of the LDD structure is effective to increase the band-gap at the junctions so that the carrier leakage is suppressed as compared with a device having no LDD structure. The improvement due to the LDD structure is particularly remarkable when the FET is a thin film transistor (TFT) because a TFT utilizes a nonuniform semiconductor material such as polysilicon forming trapping levels therein which are considered to originate from grain boundaries.

The reverse current leakage is furthermore suppressed by increasing the band-gap of the LDD regions. FIG. **4(D)** illustrates the energy band structure of a semiconductor device with LDD regions having wide band-gaps when no gate signal is supplied. FIG. **4(E)** illustrates the energy band structure of the same semiconductor device when a large gate voltage is supplied in the reverse direction. As shown in the figures, the band-gaps at the LDD regions are substantially increased as compared with the case shown in FIGS. **4(B)** and **4(C)**. The probability of tunnel current through the LDD regions quickly decreases as the band-gap (barrier) increases. The hopping through local levels in the band-gap is also decreased by increasing the band-gap because the mechanism of hopping is also based upon

combinational tunnel effects. For this reason, LDD structure having a wide band-gap is advantageous with respect to improvement of FET characteristics. In this sense, noncrystal semiconductor materials, e.g. amorphous silicon having 1.8 eV band-gap is considered to be useful for forming an equivalent structure whereas the band-gap of polysilicon is 1.1 eV.

The band-gap is increased also by introducing other suitable impurities such as carbon, nitrogen, oxygen and so forth into silicon semiconductors at appropriate stoichiometrical or non-stoichiometrical ratios in order to obtain the same effects. The impurities such as carbon, nitrogen, oxygen are not so desirable for silicon semiconductors so that low densities thereof is favorable in general. In accordance with the present invention, no such impurities are utilized. The densities of such impurities are desirably reduced to  $7 \times 10^{19} \text{ cm}^{-3}$  or less in the following embodiments in order to make excellent devices.

#### BRIEF DESCRIPTION OF THE DRAWINGS

The accompanying drawings, which are incorporated in and form a part of the invention and, together with the description, serve to explain the principles of the invention.

FIGS. **1(A)** to **1(D)** are cross sectional views showing a conventional method of manufacturing a thin film field effect transistor having LDD regions.

FIGS. **2(A)** to **2(C)** are cross sectional views showing basic steps of a method of manufacturing a thin film field effect transistor having LDD regions in accordance with the present invention.

FIGS. **3(A)** to **3(D)** are cross sectional views showing a method of manufacturing a thin film field effect transistor having LDD regions in accordance with a first embodiment of the present invention.

FIG. **4(A)** is a graphic diagram showing the relationship between the drain current and the gate voltage of a prior art thin film field effect transistor having no LDD regions and a thin film field effect transistor having LDD regions in accordance with the present invention.

FIGS. **4(B)** to **4(E)** are energy band diagrams demonstrating the effect of LDD structures.

FIGS. **5(A)** to **5(E)** are cross sectional views showing a method of manufacturing a thin film field effect transistor having a new structure equivalent to LDD regions in accordance with a second embodiment of the present invention.

FIGS. **6(A)** to **6(C)** are plan views showing an application of the second embodiment of the present invention.

FIGS. **7(A)** to **7(C)** are circuit diagrams for explaining the application of the second embodiment of the present invention.

FIGS. **8(A)** to **8(D)** are cross sectional views showing a method of manufacturing a thin film field effect transistor having a new structure equivalent to LDD regions in accordance with a third embodiment of the present invention.

FIGS. **9(A)** to **9(C)** are plan views showing a method of manufacturing a thin film field effect transistor having a new structure equivalent to LDD regions in accordance with a fourth embodiment of the present invention.

FIGS. **10(A)** to **10(D)** are cross sectional views showing a method of manufacturing a thin film field effect transistor having a new structure equivalent to LDD regions in accordance with a fourth embodiment of the present invention.

#### DETAILED DESCRIPTION OF THE PREFERRED EMBODIMENTS

Referring now to FIGS. **3(A)** to **3(D)**, a method of manufacturing an n-channel thin film field effect transistor in

accordance with a first embodiment of the present invention will be explained.

A low temperature oxide film **302** is deposited on a quartz substrate **301** by low pressure CVD to a thickness of 10 to 500 nm, for example, 100 nm as illustrated in FIG. **3(A)**. An intrinsic amorphous silicon semiconductor film is deposited in the same manner over the oxide film **302** by low pressure CVD to a thickness of 10 to 100 nm, for example, 20 nm. Alternatively, by elevating the deposition temperature, the semiconductor film is deposited in a microcrystalline or polycrystalline phase instead of the amorphous phase. The amorphous semiconductor film may be deposited by plasma CVD or photo-CVD instead of low pressure CVD. A rectangular active region of 10 micrometers $\times$ 30 micrometers is separated from the amorphous film by patterning and exposed to laser light emitted from a KrF excimer laser in order to crystallize the active region. The wavelength of the laser light is 428 nm. The pulse width is 10 nsec. The energy density is 150 to 250 mJ/cm<sup>2</sup>, for example, 200 mJ/cm<sup>2</sup>. The desired crystallization is completed by irradiation of 1 to 10 laser pulses.

A silicon oxide film is then deposited on the crystallized semiconductor film to a thickness of 50 to 150 nm, for example, 70 nm by ECR plasma CVD. An aluminum film is next deposited on the oxide film to a thickness of 100 to 800 nm, for example, 500 nm by electron beam vacuum evaporation. These oxide and aluminum films are patterned to form an aluminum pattern **303** to be a gate electrode and a gate insulating film **304**. The lateral dimension of the pattern **303** and film **304** (in the right to left direction of the drawing) is 500 nm for example. Arsenic ions are introduced to the semiconductor film by ion implantation in order to form n-type impurity regions **305** having a doping concentration of  $1 \times 10^{17}$  to  $5 \times 10^{18}$  cm<sup>-3</sup>, preferably  $1 \times 10^{17}$  to  $2 \times 10^{18}$  cm<sup>-3</sup>, for example,  $2 \times 10^{18}$  cm<sup>-3</sup>. The ion implantation makes the impurity regions amorphous.

Next, as illustrated in FIG. **3(B)**, the upper and side surfaces of the aluminum pattern **303** are anodic oxidized to form an aluminum oxide film **306** of 200 nm thickness covering the pattern. The anodic oxidation is carried out, for example, by immersing the substrate in an electrolyte. The electrolyte is prepared by diluting L-tartaric acid with ethylene glycol and its pH is controlled to be  $7.0 \pm 0.2$  by adding ammonia thereto. A 20 mA DC current is passed through the electrolyte with the substrate as a positive electrode and a platinum plate as a negative electrode. The anodic oxidation is continued with the constant current of 20 mA whereas the voltage between the positive and negative electrode is increased to 100 V. After the voltage reaches to 100 V, the oxidation is further continued with the voltage maintained at 100 V whereas the current is gradually reduced to 0.1 mA. Then, the aluminum oxide film **306** is formed enclosing the gate electrode therein. With the aluminum oxide film **306** as a mask, arsenic ions are introduced into the semiconductor film by ion implantation in order to form n<sup>+</sup>-type impurity regions **307** outside of n<sup>-</sup>-type regions **308**. The doping concentration of the impurity regions **307** is  $1 \times 10^{20}$  to  $5 \times 10^{21}$  cm<sup>-3</sup>, for example,  $0.8 \times 10^{21}$  cm<sup>-3</sup>.

The impurity regions **307** are then exposed to laser light in order to crystallize the impurity regions **307**, leaving the regions **308** noncrystalline, whose advantages have been already explained in SUMMARY OF THE INVENTION. During the laser exposure, the gate electrode is protected by the aluminum oxide film **306**. The gate electrode might otherwise be expanded, melted or rubbed resulting in serious damage thereof. Even if the gate electrode is melted for a moment, its configuration is maintained by the enclosure of

the aluminum oxide film resulting in no problem. The structure is next given passivation for 2 hours at 250 $^{\circ}$ C. in hydrogen of atmospheric pressure in order to improve semiconductive characteristics of the respective regions of the semiconductor film by reducing the influence of local energy levels of the semiconductor film. A phosphosilicate glass film **309** is deposited over the structure by low pressure CVD at 450 $^{\circ}$ C. The reactive gas used is composed of SiH<sub>4</sub>, O<sub>2</sub> and PH<sub>3</sub>. Finally, contact holes are opened through the phosphosilicate glass film **309** followed by forming aluminum electrodes **310** in order to make contact with the impurity regions **307** through the contact holes. As a result, the formation of a thin film transistor comprising the LDD regions located between the drain and source regions and the channel region is completed as illustrated in FIG. **3(D)**. The channel width is 20 micrometers. The channel length is 500 nm between the noncrystal regions of 100 nm length corresponding to the thickness of the oxide film **306**.

Actually, the gate electrode is an extension of a gate wiring also anodic oxidized and provided for supplying a gate signal. The oxide film coated over the gate wiring extending from the gate electrode is effective to prevent it from making short with other wirings. In the case of a matrix circuit for a liquid crystal display, for example, gate wirings are formed to intersect and be isolated from many other signal lines through an interlayer insulating film by grade separation (level crossing). However, the withstand voltage and uniformity of such an interlayer insulating film are low so that short current paths are often formed therethrough. The formation of such short current paths is a most serious problem to improve yield of liquid crystal matrices. In accordance with the present invention, since gate wirings are coated with a dense oxide film devoid of pinholes and having a large withstand voltage, the possibility of forming short current paths is very low and therefore the yield of liquid crystal displays is substantially improved.

FIG. **4(A)** is a graph showing the relationship between the drain current and the gate voltage. Curve A is plotted in the case of a thin film transistor having a channel region of 0.5 micrometer $\times$ 20 micrometers and noncrystal regions **308** of 0.1 micrometer width. Curve B is plotted in the case of a conventional thin film transistor having a channel region of 0.5 micrometer $\times$ 20 micrometers but not provided with noncrystal regions. 5 V is applied between the source and the drain during the measurement for both cases. As shown in the figure, it will be understood that the present invention is effective to suppress not only reverse current leakage but also current leakage in off-state ( $I_d$  with  $I_g=0$ ). The later suppression is particularly important in the case of the application to active matrix liquid crystal displays because when current leakage is substantial in the off-state, electric charge escapes from capacitances associated with respective pixels.

Referring now to FIGS. **5(A)** to **5(E)**, FIGS. **6(A)** to **6(C)** and FIGS. **7(A)** to **7(C)**, initially to FIGS. **5(A)** to **5(E)**, a method of manufacturing complementary thin film field effect transistors in accordance with a second embodiment of the present invention will be explained.

An intrinsic amorphous silicon semiconductor film is deposited on a substrate of Corning 7059 glass substrate to a thickness of 150 nm by plasma CVD and crystallized in nitrogen at 600 $^{\circ}$ C. for 60 hours. A pair of island-shaped rectangular active regions **502** and **503** are separated from the amorphous film by patterning.

A silicon oxide film is then deposited on the substrate **501** over the active regions to a thickness of 115 nm by sput-



tering. An aluminum film is next deposited on the oxide film to a thickness of 100 to 800 nm, for example, 500 nm by electron beam vacuum evaporation. The aluminum film is patterned to form aluminum patterns **506** and **507** of 8 micrometers width (in the left to right direction) to be a gate electrode as illustrated in FIG. 5(A) and aluminum wirings **505** and **508** which are utilized for general purposes. After covering the active region **503** with a photoresist **509**, boron ions ( $B^+$ ) or boron fluoride ions ( $BF_3^+$ ) are introduced to the active region **502** by ion implantation with the aluminum pattern **506** as a mask in order to form p-type impurity regions **510** having a doping concentration of  $1 \times 10^{13}$  to  $5 \times 10^{13} \text{ cm}^{-2}$ . The ion energy is 70 to 100 keV. The impurity regions may be formed by directing a dopant plasma gas to the active region called as plasma doping. Anyway, the impurity regions are damaged by ion bombardment or plasma bombardment and their crystalline structure is broken into a substantially noncrystalline phase. After covering the active region **502** with a photoresist **511**, phosphorus ions ( $P^+$ ) are introduced to the active region **503** by ion implantation with the aluminum pattern **507** as a mask in order to form n-type impurity regions **512** in the same manner as illustrated in FIG. 5(C).

Next, as illustrated in FIG. 5(D), the upper and side surfaces of the aluminum patterns **506** and **507** and the wirings **505** and **508** are anodic oxidized to form aluminum oxide films **513** to **516** covering the exposed surfaces of these patterns and wirings. The anodic oxidation is carried out, for example, by immersing the substrate in an electrolyte at  $24 \pm 2^\circ \text{ C}$ . The electrolyte is prepared by preparing an ethylene glycol solution of L-tartaric acid (3%) and neutralizing it ( $\text{pH} = 7.0 \pm 0.2$ ) by adding aqueous ammonia (5%) thereto. A DC current is passed through the electrolyte with these aluminum patterns and wirings as a positive electrode and a platinum plate as a negative electrode. These aluminum patterns and wirings have been formed to be electrically connected to each other so that connection with the positive terminal of a voltage source can be made at once. The integral connection of these aluminum patterns and wirings is only for this anodizing, and therefore these patterns and wirings will be appropriately separated later for actual purposes of the electric circuit. The anodic oxidation is continued with the constant current of 0.5 mA whereas the voltage between the positive and negative electrodes is gradually increased. After the voltage reaches to 250 V, the oxidation is further continued with the voltage maintained at 250 V whereas the current is gradually reduced. When the current is reduced to  $0.005 \text{ mA/cm}^2$ , the oxidation is stopped by ceasing the current supply. Then, the aluminum oxide films **513** to **516** of a thickness of 320 nm are formed enclosing the gate electrodes and wirings as illustrated in FIG. 5(D). With the aluminum oxide films **514** and **515** as a mask, the impurity regions **510** and **512** are subjected to laser annealing by means of a KrF excimer laser to partially crystallize the impurity regions. During the laser annealing, the substrate **501** is mounted on an XY stage in air (at  $10^2$  Torr or higher pressure). A flat laser beam of  $1 \times 300 \text{ mm}^2$  is moved with respect to the stage in order to completely irradiate the substrate from one edge to the opposite edge. The wavelength of the laser light is 428 nm. The pulse width is 10 nsec. The power density is  $350 \text{ mJ/cm}^2$ . The desired crystallization is completed by radiation of 50 laser pulses. During the laser annealing, the gate electrode is protected by the aluminum oxide films **513** to **516**. The oxide films **513** to **516** function to prevent the laser beam from reaching the portions of the impurity regions **510** and **512** that located just under the oxide films. Noncrystal regions **518** and **520** are

therefore left and defined aside the crystallized regions **517** and **519** as illustrated in FIG. 5(D). The dimension of the noncrystal regions **518** and **520** correspond to lateral increment caused by the oxidation of aluminum, as denoted by reference "b". The increment "b" is the thickness of the aluminum oxide film **514** minus the regression of the aluminum pattern denoted by reference "a". The regression "a" of the aluminum pattern is usually  $\frac{1}{3}$  to  $\frac{1}{2}$  of the thickness of the oxide film. In typical cases, "a" is selected to be 0.1 to 0.2 micrometer and "b" to be 0.03 to 0.2 micrometer so that desired characteristics are obtained. Accordingly, a pair of the wide-gap n-type (noncrystalline) regions are formed inside of the relatively narrow-gap n-type (crystallized) regions with a channel region therebetween as illustrated in the right side of FIG. 5(D). As illustrated in the left side of FIG. 5(D), a pair of the wide-gap p-type regions are also formed inside of the relatively narrow-gap p-type regions with a channel region therebetween in the same manner.

In accordance with experiments, during partial crystallization of the semiconductor film by the laser annealing, the aluminum oxide films **513** to **516** were sometimes observed with cracks, fissures, holes and aluminum which issued therethrough and consolidated because of the laser shock. The aluminum appearing from these defects was anodic oxidized again by means of the same electrolyte and electrodes in order to stop the defects opened through the oxide films. The current to be passed through the electrolyte must be carefully adjusted in this case. Since the area of aluminum exposed through the oxide film was very small as compared to the case of the previous oxidation, substantial heat was generated by concentration of the current to destruct the structure by chemical reactions (undesirable oxidation) when the current was supplied in the same manner as in the case of the previous oxidation. For this reason, the current was gradually increased, monitoring the voltage being applied. The typical level of the current to be initially applied was 1 to 5% of that of the previous oxidation. This initial current was 5 microampere/cm<sup>2</sup> for example. The voltage was elevated by 2 V per minutes. When the voltage reached 250 V, the current supply was ceased to complete the anodic oxidation. The appropriate level of the final (maximum) voltage depends on the thickness of the oxide film. Experiences of the inventors seemed to show that the maximum voltage be directly proportional to the thickness of the oxide film. Namely, 250 V corresponds to 320 nm.

The defects of the insulation of the gate electrodes and the wirings can be eliminated in the above manner. The aluminum gate electrode and wirings, which have been integrally formed for the purpose of anodic oxidation, are then appropriately separated by laser processing in air in order to form the desired circuit. The laser employed in this process is a Q-switched Nd:YAG laser (1064 nm wavelength) excited by a flush lamp. For the purpose of this laser process, the second order harmonic waves are utilized (532 nm wavelength) in the form of pulses. The spot diameter of the laser pulses is 5 micrometers. The energy density of the laser pulses is  $1 \text{ KJ/cm}^2$ . The pulse width is 5 nano seconds. The substrate is moved in a XY stage in order that the laser pulses are incident upon the sites to be separated. A well-known photolithography may be used instead of this laser processing depending upon the actual case. In general, from the view points of cost of massproduction, photolithography is suitable for such cases that there are many or wide sites to be processed or geometrically complicated sites to be processed whereas laser processing is suitable for such cases

that the sites to be processed are geometrically simple or limited in area or not so many.

The substrate is then transported to the vacuum chamber of a CVD apparatus. An interlayer insulating film **521** made of silicon oxide is deposited in the chamber and contact holes are opened therethrough with a suitable photoresist pattern by etching which selectively removes part of the insulating film **521** and part of the aluminum oxide films **513**. Accordingly, the etching rates to silicon oxide and aluminum oxide are desirably greater than those of silicon and aluminum. In the case of an etchant (buffered hydrofluoric acid) prepared for wet etching by mixing a water solution (40 wt %) of ammonium fluoride and a water solution (50 wt %) of hydrogen fluoride, which have been highly purified for use in semiconductor manufacture, the etching rates to aluminum oxide is 60 nm/min and that to aluminum 15 nm/min. On the other hand, in the case of the reactive ion etching by the use of carbon tetrafluoride, aluminum and aluminum oxide are hardly etched whereas silicon oxide is etched at 10 nm/min for example. As etching conditions for this reactive ion etching, for example; the gas flowing rate is 20 SCCM; the reaction pressure is 0.08 Torr; and RF power supplied is 100 W. By utilizing both the etching methods, the contact holes can be formed. Namely, the interlayer oxide film **521** and the oxide film **504** are partially removed by the reactive ion etching followed by the wet etching with the buffered hydrofluoric acid which partially removes the aluminum oxide films **513**.

Finally, necessary metallic wirings are formed over the structure in order to make contact with the impurity regions **517** and **519** and the aluminum wirings **505**. As a result, a pair of complementary MOSFETs comprising an n-type transistor and a p-type transistor are formed.

FIGS. 6(A) to 6(C) and FIGS. 7(A) to 7(C) illustrate an exemplary application of the above second embodiment for forming a switching circuit of a liquid crystal display. In the figures, only circuits for two pixels are shown for the purpose of explanation wherein the active regions comprising the sources, drains and channels for the n-channel transistor and the p-type transistor are illustrated as dashed and dotted areas respectively. FIGS. 6(A) and 7(A) correspond to FIG. 5(C) from which the mask **511** is removed. In this condition, the anodic oxidation is carried out by connecting the positive terminal of a voltage source to a common electrode **550** which are electrically coupled with all the aluminum patterns **505** to **508** so that the electrical connection to the patterns is made at once. The integral connection of the electrode **550** to the patterns are separated by laser processing as depicted by numerals **551** and **552** in FIG. 6(B) after the completion of the anodic oxidation. Employment of laser processing is appropriate in this case because the portions of the aluminum patterns to be removed are not so many and have small areas. Then, necessary wirings are formed by means of the metallic wirings **522**, **523** and **524** (FIG. 5(E)) to complete the formation of the circuit as shown in FIG. 6(C). FIGS. 7(A) to 7(C) are circuit diagrams corresponding to FIGS. 6(A) to 6(C) respectively. N-type transistors on a same row are made conductive by supplying a gate signal through line **562** (FIG. 7(C)). By this condition, p-channel transistors on the same row are selectively made conductive in accordance with data signals supplied through lines **561** connected respectively to the gates of the p-channel transistors. Then, a high voltage supplied to line **563** is selectively transferred to the drain terminals of the p-channel transistors which are illustrated opened but connected to respective electrodes of pixels in the actual cases.

Referring next to FIGS. 8(A) to 8(D), a method of manufacturing a thin film field effect transistor in accordance with a third embodiment of the present invention will be explained.

A silicon oxide film **802** is deposited on a substrate **801** of Corning 7059 glass to a thickness of 100 nm by sputtering. An intrinsic amorphous silicon semiconductor film is then deposited on the oxide film **802** to a thickness of 50 nm by plasma CVD. Another silicon oxide film **804** is further deposited on the semiconductor film to a thickness of 20 nm by sputtering for the purpose of protection of the semiconductor film. The semiconductor film is then crystallized by thermal annealing in nitrogen at 600° C. for 72 hours. These semiconductor film and the silicon oxide film are partially removed to leave an island-shaped rectangular active region of 30 micrometers length in the left-right direction and 20 micrometers width normal to the drawing sheet as denoted by numerals **803** followed by removing the protective oxide film **804**. The removal of the oxide film is carried out by the use of the etchant comprising the buffered hydrofluoric acid which has been explained for the previous second embodiment.

The structure is coated with a gate insulating film **805** of 115 nm thickness by sputtering in oxygen atmosphere with a target of silicon oxide. The gate insulating film **805** is next doped with phosphorous ions by plasma doping. This doping is carried out for the purpose of gettering of movable ions such as sodium ions existing in the gate insulating film. The plasma acceleration energy is 10 keV. The doping density is  $2 \times 10^{14} \text{ cm}^{-2}$ . After the plasma doping, damage to the silicon semiconductor and oxide films is cured by annealing at 600° C. for 24 hours. This doping may be dispensed with if the density of such impurity ions is so low as not to hinder the normal operation of the device.

An aluminum film is next deposited on the oxide film **805** by sputtering and patterned to form an aluminum pattern **806** of 8 micrometers width (in the left to right direction) to be a gate electrode by patterning with an etchant prepared by adding 5% nitric acid to phosphoric acid. The etching rate is, for example, 225 nm/min at 40° C. With the aluminum pattern **806** as a mask, phosphorous ions are introduced to the semiconductor active region by ion implantation in order to form n-type impurity regions **807** having a doping concentration of  $5 \times 10^{15} \text{ cm}^{-2}$ . The ion energy is 80 keV. The doping is carried out by through-implantation through the oxide film **805** as illustrated in the figure. The presence of the oxide film during the implantation guarantees the smoothness of the surface of the impurity regions **807** even when laser annealing is given to the impurity regions to crystallize them in a later step. The surfaces might become uneven, otherwise, due to a number of crystal seeds generated on the surfaces during the crystallization process. The structure as illustrated in FIG. 8(B) is obtained in this manner. The impurity regions **807** become noncrystalline, i.e. amorphous or polycrystal (nearly amorphous) due to the ion implantation.

Next, as illustrated in FIG. 8(C), the upper and side surfaces of the aluminum pattern **806** are anodic oxidized to form aluminum oxide film **808** covering the exposed surfaces of the pattern. The anodic oxidation is carried out, for example, by immersing the substrate in an electrolyte at  $25 \pm 2^\circ \text{ C}$ . The electrolyte is prepared by preparing an ethylene glycol solution of L-tartaric acid (3%) and neutralizing it ( $\text{pH} = 7.0 \pm 0.2$ ) by adding aqueous ammonia (5%) thereto. A DC current is passed through the electrolyte with the aluminum pattern **806** as a positive electrode and a platinum plate as a negative electrode. The anodic oxidation is con-

tinued with the constant current of 0.5 mA whereas the voltage between the positive and negative electrodes is gradually increased. After the voltage reaches to 200 V, the oxidation is further continued with the voltage maintained at 200 V whereas the current is gradually reduced. When the current is reduced to 0.005 mA/cm<sup>2</sup>, the oxidation is stopped by ceasing the current supply. Then, the aluminum oxide film **808** of a thickness of 250 nm is formed enclosing the gate electrode as illustrated in FIG. **8(C)**. With the aluminum oxide film **808** as a mask, laser annealing is carried out by means of a KrF excimer laser to partially crystallize the semiconductor active region. The power density is 350 mJ/cm<sup>2</sup>. The desired crystallization can be completed only by one pulse. The pulse radiation, however, is desirably repeated in order to cope with variation of laser conditions. On the other hand, excessive annealing is not desirable from the view point of productivity. In practice, irradiation with 10 or thereabout pulses may be appropriate in many cases. The laser annealing can be carried out in air because the impurity regions are covered by the oxide film **805**. If the impurity regions are exposed, the laser annealing must be carried out in vacuum in order to avoid entrance of oxygen which substantially degrades the characteristics of the device.

The laser pulses are projected in a slanting direction as illustrated in FIG. **8(D)**, e.g. at 10 degree angularly distant from the normal to the substrate. The angle is determined in accordance with the desired geometry of the structure. The crystallized impurity regions are asymmetrically formed in this manner. Namely, regions **809** and **810** are sufficiently crystallized. The region **911** adjacent to the crystallized region **809** has not been ion implanted but is crystallized by the laser pulses. The region **912** adjacent to the crystallized region **810** is a region which has been ion implanted but is not crystallized. Actually, the region **810** is designed to be a drain which is provided with the noncrystal region **912** for suppressing hot electron effects because hot electron effects are likely particularly in the vicinity of drain regions in general rather than in the vicinity of source regions.

Subsequent steps are carried out in the same manner as those for the second embodiment so that redundant explanation of details is omitted. Namely, an interlayer insulating film is deposited by sputtering followed by opening contact holes by photolithography and providing necessary electrodes and wirings.

In accordance with the present invention, the level of current leakage, the switching speed and the withstand voltage can be controlled by appropriately designing the noncrystal regions with respect to the other parameters. For example, necessary characteristics suitable for the application can be obtained by optimizing the thickness of the anodic oxidized film, the acceleration energy of ion implantation or other parameters. It is, however, difficult to arbitrarily adjust these parameters for respective devices formed on a same substrate. For example, in some applications, it is desired to form a transistor having a high withstand voltage and a transistor having a low withstand voltage but a high switching speed on a same substrate. In accordance with the present invention or the invention disclosed in Japanese patent disclosure No. Hei3-237100, the withstand voltage and the off-state current leakage can be improved by increasing the offset region. In the followings, an embodiment of forming transistors having different characteristics on a same substrate will be described.

Referring now to FIGS. **9(A)** to **9(C)** and FIGS. **10(A)** to **10(D)**, a method of manufacturing a pair of thin film field effect transistors in accordance with a fourth embodiment of

the present invention will be explained. Particularly, the transistors are designed to be driver circuits for a liquid crystal display. The structure illustrated in FIGS. **9(A)** and **10(A)** is formed in the same manner as the structure shown in FIGS. **5(C)** and **6(A)**. Namely, n-type and p-type transistors are formed on a glass substrate. Aluminum patterns **906** and **907** are anodic oxidized with a common line **950** as a positive electrode in the same manner as in the second embodiment. The maximum voltage, however, is 50 V in this case. Aluminum oxide films **913** and **914** are then formed to a thickness of 60 nm.

Next, the conductive line connected to the gate electrode **906** of the n-type transistor is cut as depicted by numeral **951** in FIG. **9(B)** by laser etching in order to disconnect the gate electrode **906** from the common line **950**. In this condition, anodic oxidation is carried out again in the same manner with the common line **950** as the positive electrode. The maximum voltage is 250 V in this case. As a result, the thickness of the oxide film enclosing the gate electrode of the p-type transistor is increased to a thickness of 300 nm as depicted by numeral **915** in FIG. **10(C)**.

The structure is then given laser annealing in the same condition as in the second embodiment in order to crystallize part of the impurity regions. The noncrystal region of the n-channel transistor (the left transistor) has little influence upon the operation. The aluminum oxide film **913**, however, is necessary for avoiding damage by laser projection. The length of the noncrystal region of the p-channel, transistor (the right transistor) is 150 to 200 nm. The length of the offset region of the p-channel transistor denoted by  $a_2$  is 100 to 150 nm.

Subsequent steps are carried out in the same manner as those for the second embodiment so that redundant explanation of details is omitted. Namely, after separating the gate electrodes for the p-channel transistors, an interlayer insulating film is deposited by sputtering followed by opening contact holes by photolithography and providing necessary electrodes and wirings as denoted by **924** and **911** for example.

The offset region  $a_1$  of the n-channel transistor is very narrow so that the switching speed is high while the off-state current is relatively large. On the other hand, the offset region  $a_2$  of the p-channel transistor is relatively long so that the switching speed is not so high while the off-state current is limited. This is very appropriate for use in driver transistors of a liquid crystal display as illustrated in FIG. **7(C)** which is also the circuit diagram for FIG. **9(C)**. The n-type transistor is driven to turn on or off the p-type transistor which maintains charge accumulated in the capacitance of a pixel. For this purpose, the thickness of the aluminum oxide film **913** is selected to be 20 to 100 nm whereas the thickness of the aluminum oxide film **915** is selected to be 250 to 400 nm. There are other applications which require such transistors having different characteristics. For example, in the case of logic circuits such as shift registers, circuit portions for logic actions are desired to consist of high speed transistors and output stages thereof to consist of transistors having high with stand voltages.

The foregoing description of preferred embodiments has been presented for purposes of illustration and description. It is not intended to be exhaustive or to limit the invention to the precise form described, and obviously many modifications and variations are possible in light of the above teaching. The embodiment was chosen in order to explain most clearly the principles of the invention and its practical application thereby to enable others in the art to utilize most

effectively the invention in various embodiments and with various modifications as are suited to the particular use contemplated. For example, the present invention can be applied to semiconductor devices made of germanium semiconductors, silicon carbide semiconductors, gallium arsenic semiconductors or other suitable semiconductors in the same manner as those utilizing silicon semiconductors.

What is claimed is:

1. An insulated gate field effect semiconductor device comprising:

- a first impurity region of a first conductivity type formed within a semiconductor substrate;
- a second impurity region of said first conductivity type formed within said semiconductor substrate;
- a channel region located between said first and second impurity regions within said semiconductor substrate;
- a gate electrode formed over said channel region through a gate insulating layer therebetween, a surface of said gate electrode covered with an anodic oxidation film thereof; and
- a third impurity region of said first conductivity type located between said channel region and at least one of said first and second impurity regions formed within said semiconductor substrate,

wherein a crystallinity of said third impurity region is lower than the crystallinity of said first and second impurity regions.

2. The insulated gate field effect semiconductor device as claimed in claim 1 wherein the band-gap of said third impurity region is wider than that of said first and second impurity regions.

3. An insulated gate field effect transistor comprising:

- a semiconductor layer formed on a substrate;
- source and drain regions formed within said semiconductor layer;
- a channel region extending between said source and drain regions within said semiconductor layer;
- a gate electrode formed on said channel region through a gate insulating layer therebetween; and
- an anodic oxide film of said gate electrode covering a surface of said gate electrode

wherein at least a lightly doped region is formed between said channel and at least one of said source and drain regions.

4. An insulated gate field effect transistor comprising:

- source and drain semiconductor regions formed on a substrate;
- a channel semiconductor region extending between said source and drain regions on said substrate;
- a gate electrode formed on said channel region with a gate insulating layer therebetween, a surface of said gate electrode covered with an anodic oxide film of said gate electrode;

wherein portions of said source and drain regions in the vicinity of said channel region have a lower degree of crystallinity than the other portions of said source and drain regions.

5. An insulated gate field effect transistor comprising:

- source and drain semiconductor regions formed on a substrate;
- a channel semiconductor region extending between said source and drain regions on said substrate;

a gate electrode formed on said channel region with a gate insulating layer therebetween;

wherein portions of said source and drain regions in the vicinity of said channel region have a lower degree of crystallinity than the other portions of said source and drain regions, and said gate electrode is offset with respect to said source and drain regions in order not to overlap said regions.

6. A semiconductor device comprising first and second insulated gate field effect transistors, each of said transistors comprising source and drain semiconductor regions formed on a substrate, a channel semiconductor region extending between said source and drain regions on said substrate, and a gate electrode formed on said channel region with a gate insulating layer therebetween, wherein portions of said source and drain regions in the vicinity of said channel region have a lower degree of crystallinity than the other portions of said source and drain regions, and said gate electrode is offset by an offset distance with respect to said source and drain regions in order not to overlap said regions,

wherein the offset distance of said first transistor is less than the offset distance of said second transistor.

7. The device of claim 6 wherein said first transistor is a n-channel transistor and said second transistor is a p-channel transistor.

8. A semiconductor device comprising first and second insulated gate field effect transistors, each of said transistors comprising source and drain semiconductor regions formed on a substrate, a channel semiconductor region extending between said source and drain regions on said substrate, a gate electrode formed on said channel region with a gate insulating layer therebetween, and an anodic oxide film formed of a material of said gate electrode and covering a surface of said gate electrode, wherein portions of said source and drain regions in the vicinity of said channel region have a lower degree of crystallinity than the other portions of said source and drain regions,

wherein a thickness of said anodic oxide film of said first transistor is thinner than a thickness of said anodic oxide film of said second transistor.

9. The device of claim 8 wherein said first transistor is an n-channel transistor and said second transistor is a p-channel transistor.

10. A semiconductor device comprising first and second insulated gate field effect transistors, each of said transistors comprising source and drain semiconductor regions formed on a substrate, a channel semiconductor region extending between said source and drain regions on said substrate, and a gate electrode formed on said channel region with a gate insulating layer therebetween, wherein portions of said source and drain regions in the vicinity of said channel region have a lower degree of crystallinity than the other portions of said source and drain regions,

wherein said portions having a lower degree of crystallinity in said first transistor are thinner, in a direction from said source or drain region including said portion to said channel region, than said portions having a lower degree of crystallinity in said second transistor.

11. The device of claim 10 wherein said first transistor is an n-channel transistor and said second transistor is a p-channel transistor.