

No. 613,092.

Patented Oct. 25, 1898.

A. B. THIELENS.
DISK HARROW.

(Application filed Mar. 11, 1898.)

(No Model.)

2 Sheets—Sheet 1.

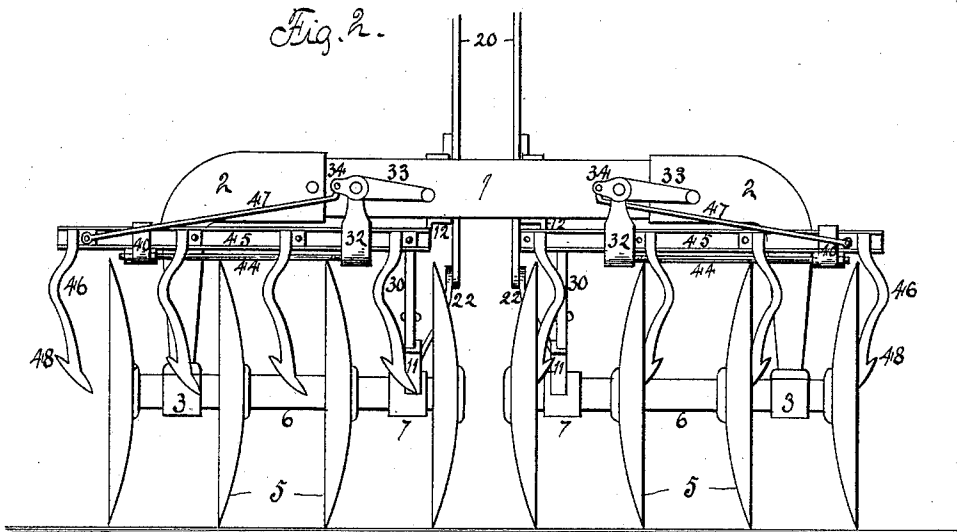
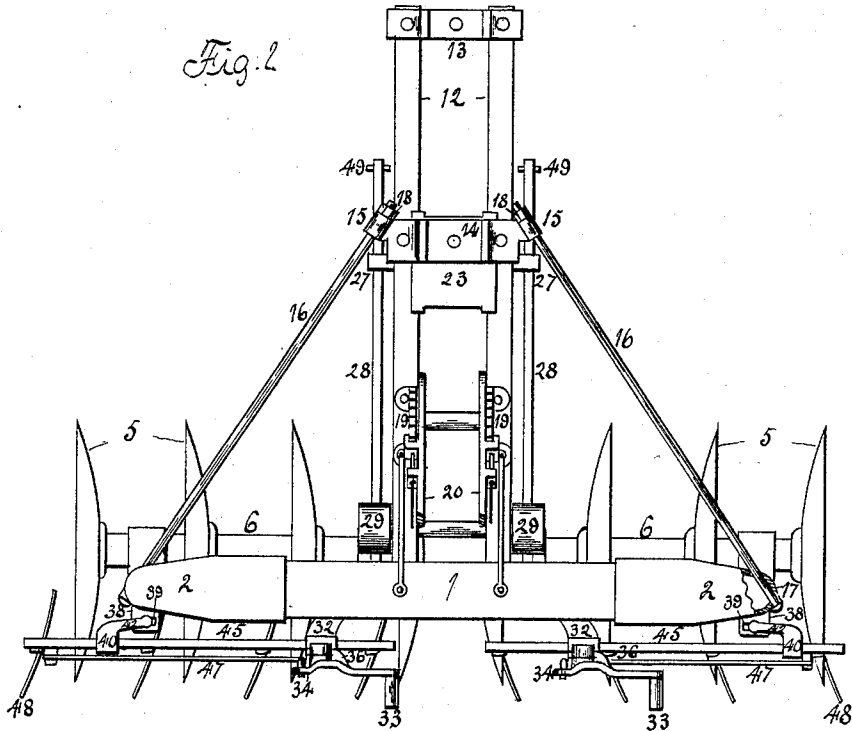

Witnesses:
Jesse C. Blake
E. Behel.

Inventor:
Alexis B. Thielen
By A. O. Behel
Atty.

No. 613,092.

Patented Oct. 25, 1898.

A. B. THIELENS.
DISK HARROW.

(Application filed Mar. 11, 1898.)

(No Model.)

2 Sheets—Sheet 2.

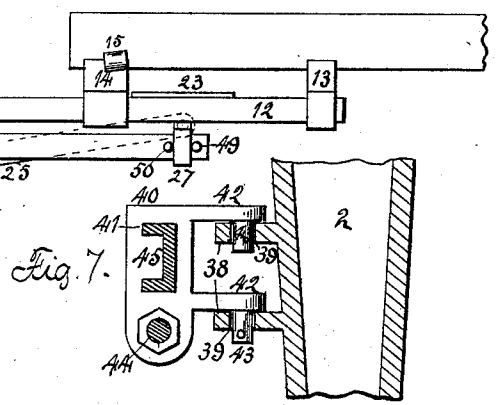
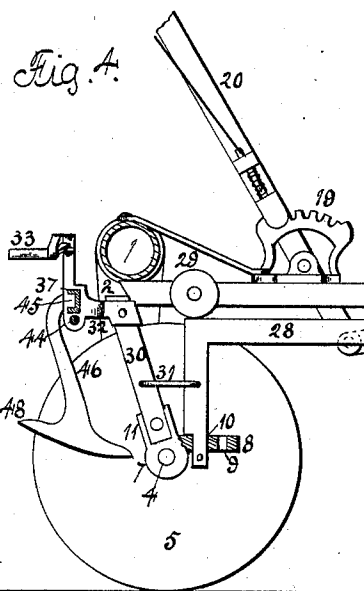
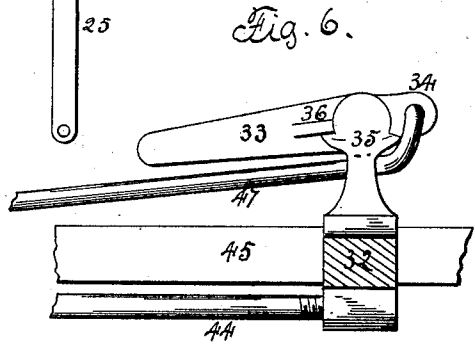
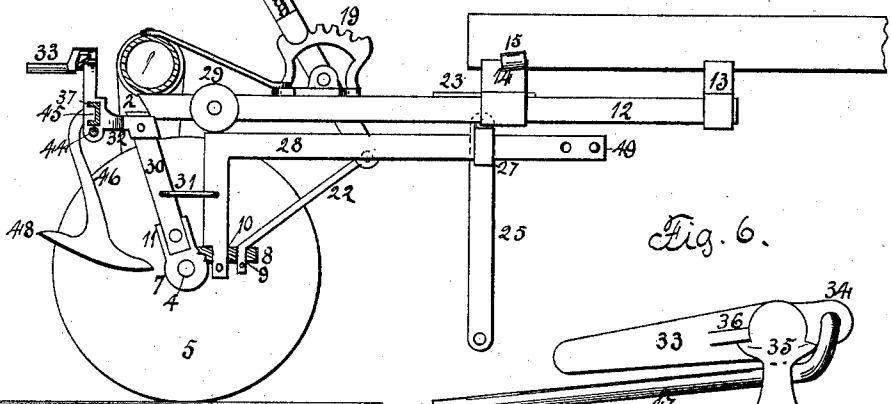
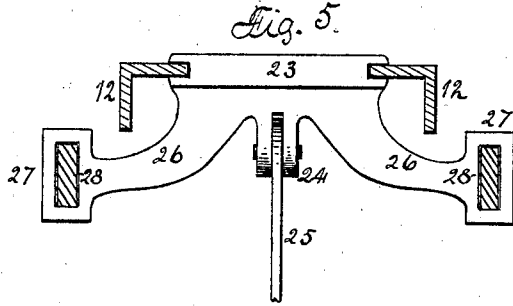
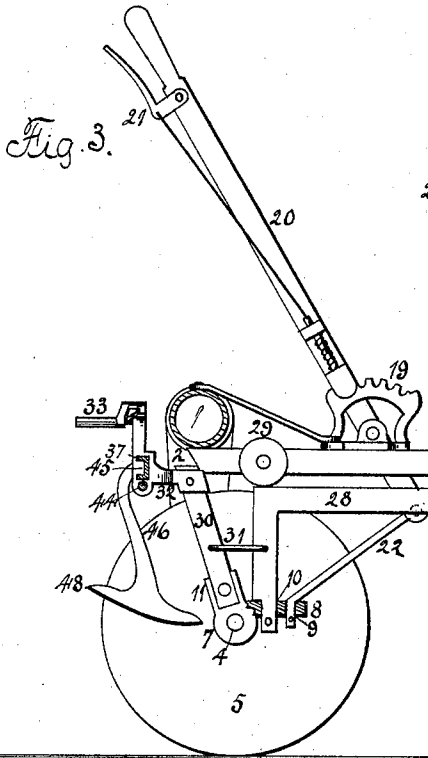

Witnesses:
Jesse C. Beaman
& O. Bechel.

Inventor:
Alexis B. Thielen
By A. O. Bechel
Atty.

UNITED STATES PATENT OFFICE.

ALEXIS B. THIELENS, OF PEORIA, ILLINOIS, ASSIGNOR TO THE EMERSON MANUFACTURING COMPANY, OF ROCKFORD, ILLINOIS.

DISK HARROW.

SPECIFICATION forming part of Letters Patent No. 613,092, dated October 25, 1898.

Application filed March 11, 1898. Serial No. 673,527. (No model.)

To all whom it may concern:

Be it known that I, ALEXIS B. THIELENS, a citizen of the United States, residing at Peoria, in the county of Peoria and State of Illinois, have invented certain new and useful Improvements in Disk Harrows, of which the following is a specification.

The object of this invention is to construct a disk harrow in which two gangs are employed, each gang having an adjusting-lever and means whereby both gangs can be adjusted by one of the levers.

The further object of this invention is the manner of supporting the scrapers and in the scraper having a portion extending beyond the rear edge of the disk, thereby preventing stalks from being carried around when they are not cut through and stick on the edges of the disks.

In the accompanying drawings, Figure 1 is a plan view of my improved harrow. Fig. 2 is a rear elevation. Fig. 3 is a lengthwise section showing the parts as a double-lever machine. Fig. 4 is a similar view in which the parts are in the position for use as a single lever. Fig. 5 is a transverse section showing the sliding head. Fig. 6 is an elevation of the lever for moving the scraper. Fig. 7 is a transverse section of the tubular end casting and the support for the outer end of the scraper-bar.

The main frame consists of the tubular center section 1 and the tubular end sections 2, secured to the main section, having their ends tapering and connected to a support 3, within which is located the rod 4, connecting the disks 5 of a gang, the disks being held separated by the spools 6, and all of the disks of a gang rotatable together in the usual manner.

Upon the rod connecting the disks of a gang and between the two inner disks of each gang is located a support 7, having a forward extension 8, provided with two vertical openings 9 and 10 and a projection 11, extending rearwardly and upwardly.

A frame supporting the gang-adjusting levers consists of the two forwardly-extending L-shaped bars 12, connected at their forward or free ends by a cross-bar 13, and their rear ends are bolted to the under face of the center tubular portion 1 of the main frame.

These L-shaped bars are connected to a cross-bar 14, having eyes 15 extending from each end thereof. A brace-rod 16, passing through an opening 17 in the tubular castings of the main frame, extends diagonally forward and passes through the eyes 15, receiving a nut 18 on its projecting screw-threaded end, the head of the rod resting against the rear face of the tubular casting, thus forming a rigid connection between the main frame and lever-supporting frame.

To the upper face of each of the L-shaped bars is secured a toothed segment 19, and to each segment is fitted a hand-lever 20, having the usual thumb-lever 21 and spring-actuated dog. Each lever has a connection with its gang by a link 22, connected to the lower end of the lever, and its other end bent in hook form and inserted in the forward hole 9 in the extension 8.

A head 23 is located between the L-shaped bars 12 and supported thereby in a manner to slide in the lengthwise direction of the bars. From the under face of this head depend two ears 24, between which is pivotally secured a link 25, and from the under face of this head extend two arms 26, each terminating in a rectangular eye 27.

To each of the extensions 8 is pivotally connected a rectangular bar 28, extending upward and forward, having its free end located in the rectangular eye 27, which acts as its guide.

The L-shaped bars 12 support two rollers 29, one located outside of each bar near the main frame and located over the horizontal portion of the bars 28, thereby holding the inner ends of the gangs down and permitting of their adjustment.

To the extension 11 is secured an arm 30, connected to the vertical portion of the arm 28 by a link 31. The upper end of the arm 30 supports a bracket 32, to the upper end of which is pivoted a hand-lever 33, provided with a perforated ear 34. The upper end of the bracket has two projections 35, against which the projection 36 of the hand-lever comes in contact, forming a stop for each extreme end of its movement. This bracket has an opening 37, extending in the lengthwise direction of the gang. From the rear

face of each of the tubular end castings 2 of the main frame extend two eyes 38, each having an elongated opening 39.

A bracket 40, having a lengthwise opening 5 41 and two arms 42, each having a depending stud 43, is connected to the eyes by the studs being located therein and a cotter passed through one of the studs holding the bracket in connection with the tubular end castings 10 of the main frame.

The brackets 32 and 40 are connected by a rod 44, which holds the brackets in a proper relative position. In the lengthwise opening of the brackets is located a channel-iron bar 15 45, to which scrapers 46 are connected, and a rod 47 forms a connection between the channel-iron bar 45 and the eye 34 of the hand-lever 33. The scrapers have a section 48, which extends beyond the rear edge of the 20 disks, which prevents stalks from being carried around when they are not cut through and stick on the edges of the disks.

When the hand-levers 20 are in the position shown in Figs. 1, 2, and 3 of the drawings, 25 each lever will have a connection with its gang by which the gang can be adjusted and held when adjusted. The outer end of the gangs being supported by their connection with the depending portion of the tubular 30 castings forming a part of the main frame, their inner ends are held down by the bars 28, resting against the rollers 29, and a pin 49 is placed through the bars 28 outside of their support 27, which prevents the bars 35 from becoming disengaged from their support.

By removing the rods 22 from a connection between the hand-lever and gangs and connecting one of the levers by the link 25 with 40 the ears depending from the under face of the sliding head and placing pins 50 through the bars 28 at the rear face of their supports 27 a connection is made between one lever and both gangs through the sliding head and 45 bars 28, by which both gangs can be adjusted in unison, the pins 49 and 50 forming the connection between the bars 28 and the sliding head, as shown in Fig. 4.

The scrapers are connected to their support 50 and the support guided in brackets. The levers connected to the scraper-supports are pivotally supported by a bracket in such a manner as to move the scrapers up against

the disks or away therefrom and lock them in either position. 55

It will be noticed that one end of the bar supporting the scrapers is supported at one end by the tubular end castings of the main frame and the other end by the disk gang. 60 It is evident that in adjusting the gangs the distance between the supports of the scraper-bar will be changed, and to permit of this movement the ears 38 are provided with the elongated openings 39.

I claim as my invention— 65

1. In a disk harrow, the combination of a supporting-frame, two disk gangs, two toothed segments, two adjusting-levers and means for forming a connection between the levers and the gangs or between one of the levers and 70 both gangs.

2. In a disk harrow, the combination of a main frame, an auxiliary frame connected to and extending forward of the main frame, a head having a sliding engagement with the 75 auxiliary frame, a hand-lever supported by the auxiliary frame having a connection with the sliding head, two disk gangs supported at their outer ends by the main frame and a connection between their inner ends and the 80 sliding head.

3. In a disk harrow, the combination of a main frame, two disk gangs connected at their outer ends to the main frame, a bracket connected with the main frame having a mov- 85 able engagement therewith, a bracket extending from the disk gang, a bar supported to move in the brackets, scrapers supported by the bar and a pivoted lever having a connection with the bar for moving the scrapers to- 90 ward and from the disks.

4. In a disk harrow, the combination of a main supporting-frame, two disk gangs connected at their outer ends to the main frame, a bracket connected with the main frame 95 having a movable engagement therewith, a bracket extending from the disk gang, a connection between the brackets, a bar supported to move in the brackets, scrapers supported by the bar and a pivoted lever having a con- 100 nection with the bar for moving the scrapers toward and from the disks.

ALEXIS B. THIELENS

Witnesses:

H. B. JILSON,
H. B. WHEELER.