

J. N. PEAVEY.  
METAL BENDING MACHINE.  
APPLICATION FILED MAR. 18, 1904.

2 SHEETS—SHEET 1.

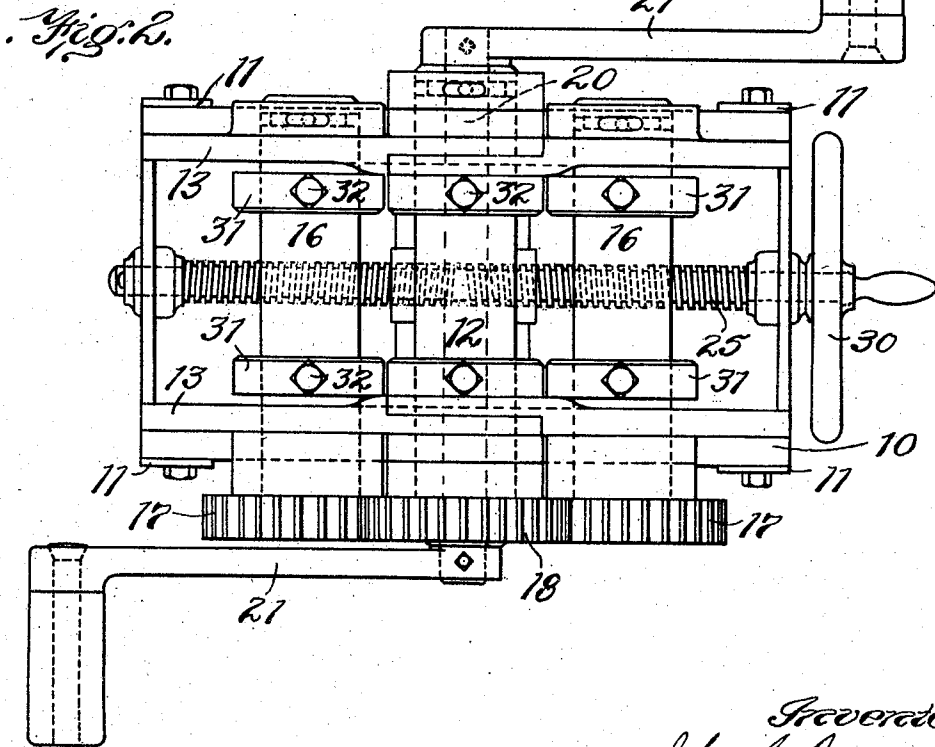
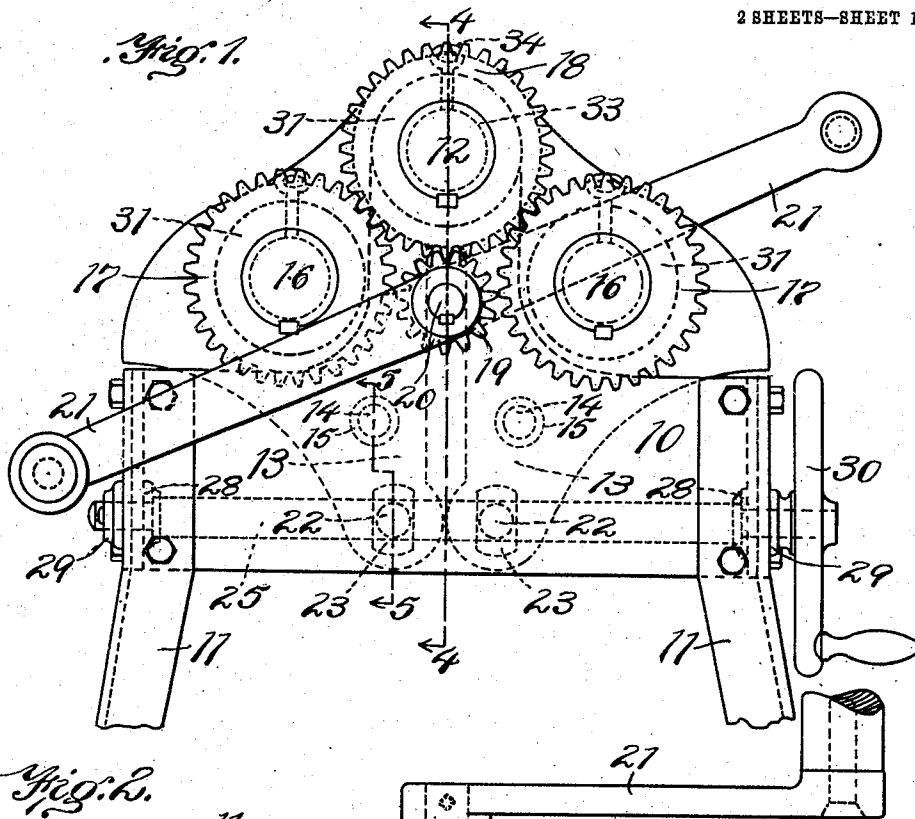

Witnesses:  
A. C. Pateman  
E. Schiller

Inventor:  
John N. Peavey  
by Wright, Brown & Quincy  
Attys

J. N. PEAVEY.  
METAL BENDING MACHINE.  
APPLICATION FILED MAR. 18, 1904.

2 SHEETS—SHEET 2.

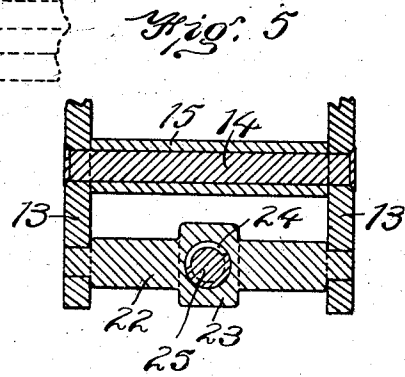
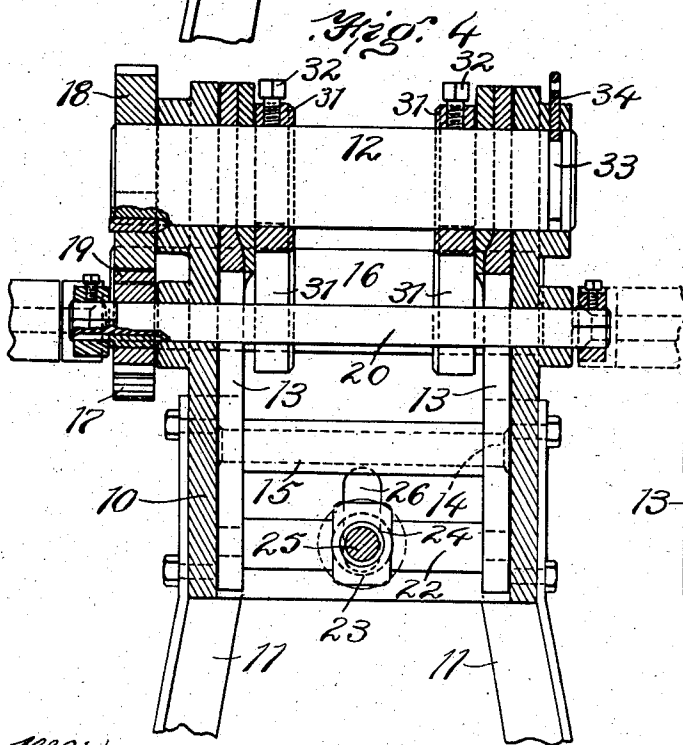
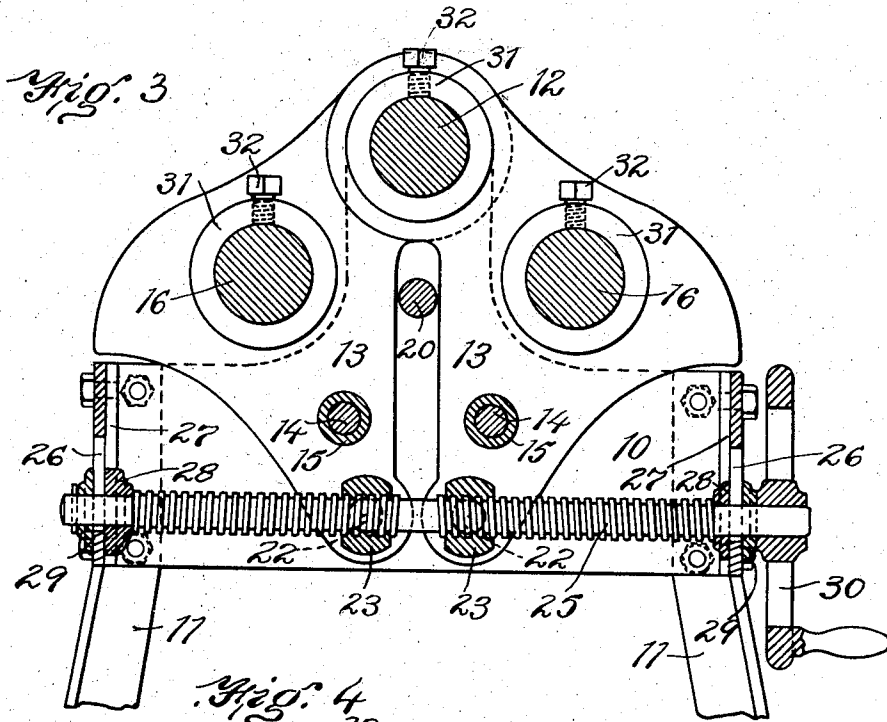

Witnesses:

A. C. Ratigan  
E. Batcheller

Inventor:

John N. Peavey  
by Wright, Brown & Quincy  
Attys

# UNITED STATES PATENT OFFICE.

JOHN N. PEAVEY, OF MANCHESTER, NEW HAMPSHIRE.

## METAL-BENDING MACHINE.

SPECIFICATION forming part of Letters Patent No. 781,355, dated January 31, 1905.

Application filed March 18, 1904. Serial No. 198,711.

*To all whom it may concern:*

Be it known that I, JOHN N. PEAVEY, of Manchester, in the county of Hillsboro and State of New Hampshire, have invented certain new and useful Improvements in Metal-Bending Machines, of which the following is a specification.

This invention relates to machines for bending metal, such as wheel-tires and other analogous articles, and has particular reference to that type of such machines which employ a plurality of rolls between the peripheries of which the tire or other article is passed endwise and given a bend according to the relative positions of the rolls.

The object of my present invention is to provide an improved construction of machine of this type in which three positively-driven rolls are employed, two of them being adjustable relatively to the third roll which will be fixed in an intermediate position between the two adjustable rolls, means being provided for positively rotating all three of the rolls at a uniform peripheral speed.

A further object of the invention is to provide a machine of this character having means whereby the article to be bent may be accurately guided, regardless of the width of said article, whereby an edgewise bend may be given to certain kinds of tires.

To these ends the invention consists in the construction and combination of parts substantially as hereinafter described and claimed.

Of the accompanying drawings, Figure 1 represents in front elevation a machine embodying my invention. Fig. 2 is a plan view of the same. Fig. 3 represents a longitudinal central section of the same. Fig. 4 represents a section on line 4 4 of Fig. 1. Fig. 5 represents a detail section on line 5 5 of Fig. 1.

The frame of the machine is represented at 10, said frame being supported upon suitable legs 11. Mounted in fixed bearings in upwardly-extending portions of the frame is the roller 12, said roller being fixed relatively to the frame—that is, said roller has no movement other than a rotary one. Pivotaly supported upon said roller 12 are yokes, each comprising two side plates 13, said plates being connected by bolts 14, spacing-sleeves be-

ing mounted on the bolts 14 and abutting at their ends against the inner walls of the plates 13, so as to rigidly hold said plates in their positions relatively to each other. Mounted in each yoke is a roller 16, each having a gear 17 keyed to it. The two gears 17 mesh with a gear 18, keyed on one end of the roller 12. Mounted in bearings in the side plates of the frame 10 and below the roller 12 is a shaft 20, having keyed thereon the actuating-pinion 19, meshing with the gear 18. Each end of the shaft 19 is squared or otherwise suitably formed to enable a crank 21 to be secured thereto, so that by the operation of either crank 21 or both of them the shaft 20 is rotated and through the pinion and gearing described will cause the rotation of the three rolls in a suitable direction to pass or feed the bar or tire to be bent between them—that is, while the two rollers 16 rotate in the same direction the roller 12 rotates in a direction opposite thereto, so that the peripheral movement of the under side of the roller 12 will be in the same direction as the peripheral movement of the upper sides of the two rollers 16.

Swiveled in the lower portions of the yokes 13 are bars 22, having intermediate enlargements 23, the latter having threaded apertures 24, the apertures of the two bars being threaded in opposite directions. Practically the bars 22 with their threaded apertures form swiveled nuts.

A right and left hand threaded shaft 25 passes through the two swiveled nuts or bars and extends through slots 26, formed in the end walls of the frame 10. The inner surfaces of said end walls are formed with ways in which are fitted slides 28, the said slides being mounted upon the shaft 25, so that the said shaft can rotate therein. Outside of the slotted end plates of the frame plates 29 are mounted upon the shaft 25 and secured against endwise movement relatively to said shaft. Upon one end of the shaft 25 is secured a hand-wheel or crank 30.

It will now be understood that by rotating the shaft 25 in either direction the two yokes are caused to simultaneously swing in opposite directions, so as to swing the rollers 16

upward or downward relatively to the roller 12, according to the direction of rotation imparted to the shaft 25; but since the cross-bars 22, forming the swiveled nuts, must swing oppositely in arcs of a circle of which the axis of roller 12 is the center the shaft 25 will move bodily vertically according to the amount of swing imparted to the yokes. The slots 26 in the end plates of the frame and the slides of blocks 28 and the plates 29 serve to smoothly guide the shaft in its said movements. It will also be understood that the amount of curvature imparted to the tire, bar, or plate that is being forcibly passed between the rolls by the rotation of the crank 21 may be quickly varied, either to change the adjustment for complete articles to be bent or for varying the curvature given to one part of a bar from that given to another part of the same bar, it being entirely feasible to adjust the relative positions of the bending-rolls, while said rolls are rotating during a given pass of the article being bent.

Sometimes it is desirable to bend a bar edgewise—that is, to pass a bar between the rolls in such position that the edges of the bar instead of the sides thereof will be in contact with the peripheries of the rolls. By this is meant, of course, bars which are of greater width than thickness. When such a bar is passed edgewise between the rolls, it would be liable to twist during its passage. To prevent this and at the same time to enable uniform bending of such bars, I adjustably secure guides upon each of the three rolls. In the present embodiment of my invention these adjustable guides comprise collars 31, having set-screws 32, by means of which the said collars can be adjusted toward or from each other or toward either end of the rolls. It is also possible to so adjust the three pairs of the guiding-collars that a lateral bend will be given to the bar as well as the usual bend imparted to a wheel-tire. For instance, referring to Fig. 2, it will be readily understood that if all the collars were set closer together than there shown, the collars of the roll 12, the bar during its pass would be given a lateral curvature due to the arrangement of the guides out of alinement with each other and also a curvature due to the relative positions of the three rolls.

In machines of this character it is sometimes desirable to remove the intermediate or upper roll, even sometimes when the work is in position between the three rolls. In order that this may be quickly and conveniently accom-

plished, I make the roll 12 of uniform diameter, so that it can be slipped through its bearings in the frame and also from the collars 31 and the portions of the yokes which are mounted thereon. At the end opposite that to which the gear 18 is secured I form a peripheral groove 33. When the parts are assembled, as shown in Fig. 4, a locking-key 34 is passed through an aperture in a portion of the frame, so as to enter the peripheral groove 33. When it is desired to remove the roll 12, it is only necessary to lift the locking-key 34, loosen the set-screws 32 of the two collars, and withdraw the roll endwise in a direction toward the left. (Shown in Fig. 4.)

I claim—

1. A machine of the character described comprising three bending-rolls geared together and relatively adjustable to vary the degree of curvature that will be imparted by said rolls, and a pair of collars mounted upon each of the three rolls for imparting an edgewise bend to a bar and having set-screws whereby they may be secured in adjusted positions lengthwise of the rolls to vary the amount of edgewise bend given to a bar.

2. A machine of the character described comprising a central roll, yokes mounted upon said roll and each carrying a roll, the three rolls having intermeshing gears, swiveled nuts carried by the lower portions of said yokes, a right and left hand threaded shaft passing through said nuts, and vertical guides for the ends of said shaft.

3. The combination with a frame having guide-slots, of a roll mounted in said frame, yokes mounted upon said roll and each carrying a roll, swiveled nuts carried by the lower portions of the yokes, a right and left hand threaded shaft passing through said nuts and through the slots of the frame, and guide-plates mounted upon the shaft on opposite sides of the slotted portions of the frame.

4. A machine of the character described comprising three rolls directly geared together, two of said rolls being mounted to be adjusted about the axis of the third roll without altering their distance therefrom, the said third roll being mounted in fixed position, means for simultaneously effecting the said adjustment of the two rolls positively in either direction, and means for rotating said rolls.

In testimony whereof I have affixed my signature in presence of two witnesses.

JOHN N. PEAVEY.

Witnesses:

WILLIAM B. BLAKE,  
BERTHA C. FRANCIS.