

(12) UK Patent Application (19) GB (11) 2569501 (13) A

(43) Date of Reproduction by UK Office 19.06.2019

(21) Application No: 1905123.4

(22) Date of Filing: 06.12.2016

Date Lodged: 11.04.2019

(86) International Application Data:  
PCT/US2016/064574 En 06.12.2016

(87) International Publication Data:  
WO2018/101953 En 07.06.2018

(51) INT CL:  
E21B 41/00 (2006.01) E21B 23/00 (2006.01)

(56) Documents Cited:  
US 6384571 B1 US 4091710 A  
US 20120088134 A1 US 20100307773 A1  
US 20030070812 A1

(58) Field of Search:  
INT CL E21B, F41F, H01M  
Other: eKOMPASS(KIPO internal)

(71) Applicant(s):  
Halliburton Energy Services, Inc  
3000 N. Sam Houston, Parkway E., Houston,  
77032-3219, United States of America

(72) Inventor(s):  
Thomas Earl Burky  
Ozegbe James Chukwuma  
Thomas J Wuensche

(74) Agent and/or Address for Service:  
Withers & Rogers LLP  
4 More London Riverside, LONDON, SE1 2AU,  
United Kingdom

(54) Title of the Invention: Force-activated thermal battery for use in a wellbore  
Abstract Title: Force-activated thermal battery for use in a wellbore

(57) A thermal battery positioned in a wellbore can be force activated by a device. The device can include a body coupled to a thermal battery positioned in a wellbore. The body can include a piston retained at a first position in an inner area of the body. The piston can move from the first position to a second position in response to a force applied to the body. The thermal battery can be activated by moving the piston to the second position.

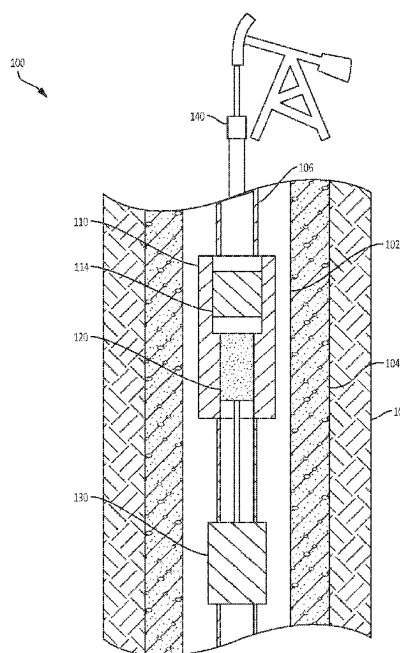

FIG. 1

GB 2569501 A