



US 20090311384A1

(19) **United States**

(12) **Patent Application Publication**
MacMahon et al.

(10) **Pub. No.: US 2009/0311384 A1**

(43) **Pub. Date: Dec. 17, 2009**

(54) **POD FOR PREPARING A BEVERAGE**

(86) PCT No.: **PCT/GB05/04113**

(76) Inventors: **John MacMahon**, Oxon (GB); **Mark Norton**, Oxon (GB); **Lee Rowan**, Oxon (GB); **Satwinder Panesar**, Oxon (GB); **Jim Ferguson**, Oxon (GB); **Adam Fennel**, Oxon (GB); **Heather Hudson**, Glenview, IL (US); **Nicholas F. David**, Glenview, IL (US); **Bary Zeller**, Glenview, IL (US); **Audrey Trouillot**, Oxon (GB); **Ken Cale**, Tarrytown, NY (US); **Joseph Giacone**, Tarrytown, NY (US); **Anilkumar Gaonkar**, Buffalo Grove, IL (US); **Susan Bodett**, Glenview, IL (US)

§ 371 (c)(1),
(2), (4) Date: **Mar. 16, 2009**

(30) **Foreign Application Priority Data**

Oct. 22, 2004 (GB) 0423545.3

Publication Classification

(51) **Int. Cl.**
B65D 85/804 (2006.01)
B65B 29/02 (2006.01)
(52) **U.S. Cl.** **426/78**; 426/77; 426/84; 426/588;
426/79; 426/431

(57) **ABSTRACT**

A pod for preparing a beverage comprising: a rigid or semi-rigid sidewall; a rigid or semi-rigid upper surface containing one more apertures forming an inlet of the pod; a lower surface formed at least partially from filtering material, the filtering material forming an outlet of the pod; the sidewall, upper surface and lower surface together defining a storage volume extending from the inlet to the outlet and containing a water-soluble composition, or a combination or mixture of water-soluble compositions for forming a beverage; wherein the rigid or semi-rigid sidewall maintains a physical separation of the filtering material and the upper surface during use.

Correspondence Address:
FITCH EVEN TABIN & FLANNERY
120 SOUTH LASALLE STREET, SUITE 1600
CHICAGO, IL 60603-3406 (US)

(21) Appl. No.: **11/577,058**

(22) PCT Filed: **Oct. 24, 2004**

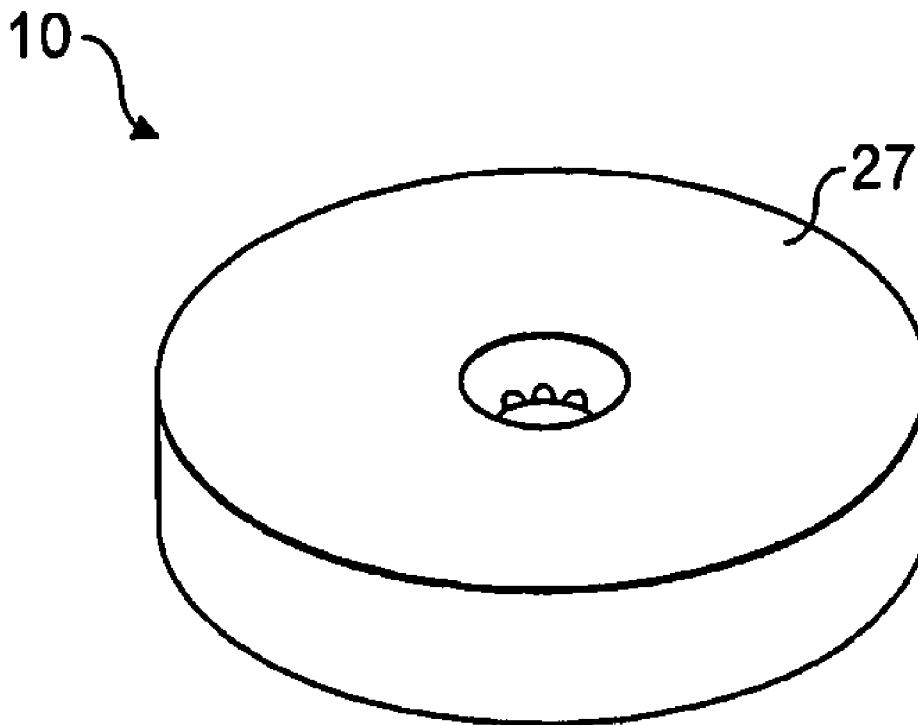

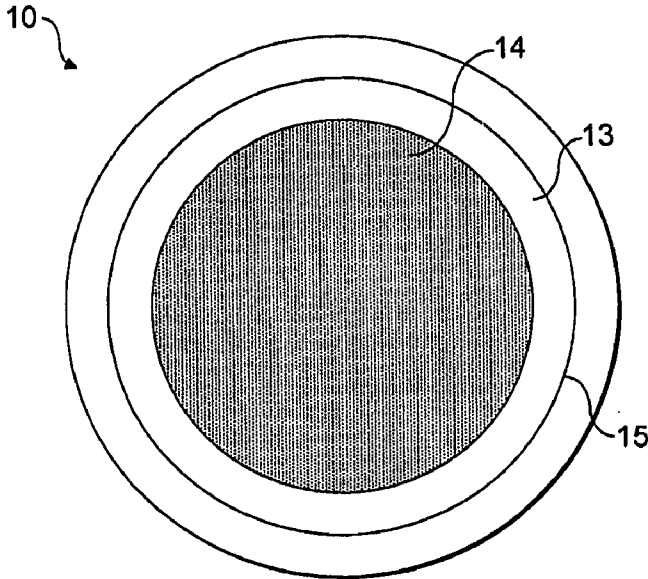

FIG. 1

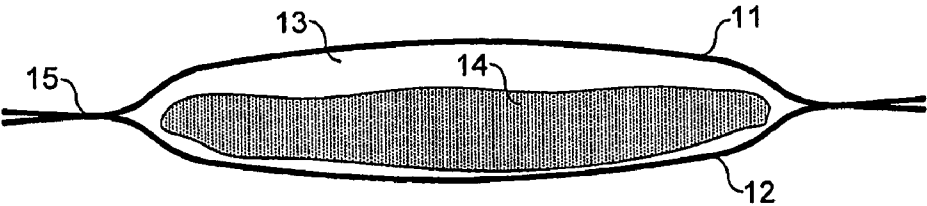

FIG. 2

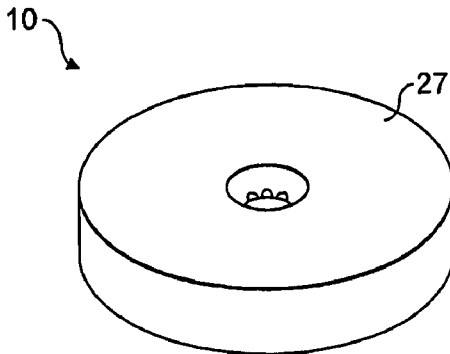

FIG. 3

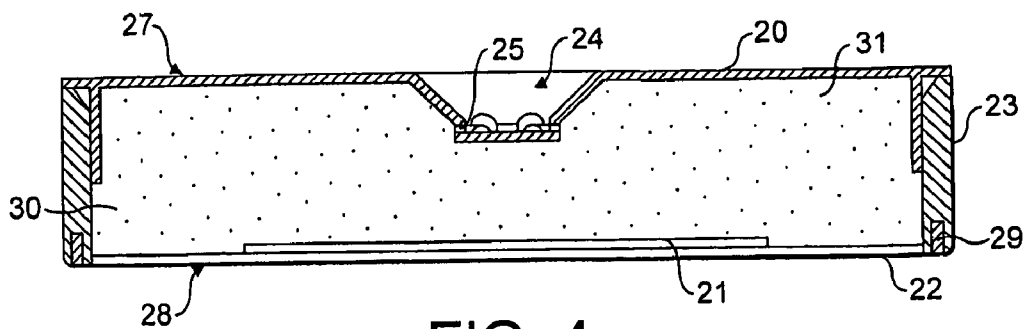

FIG. 4

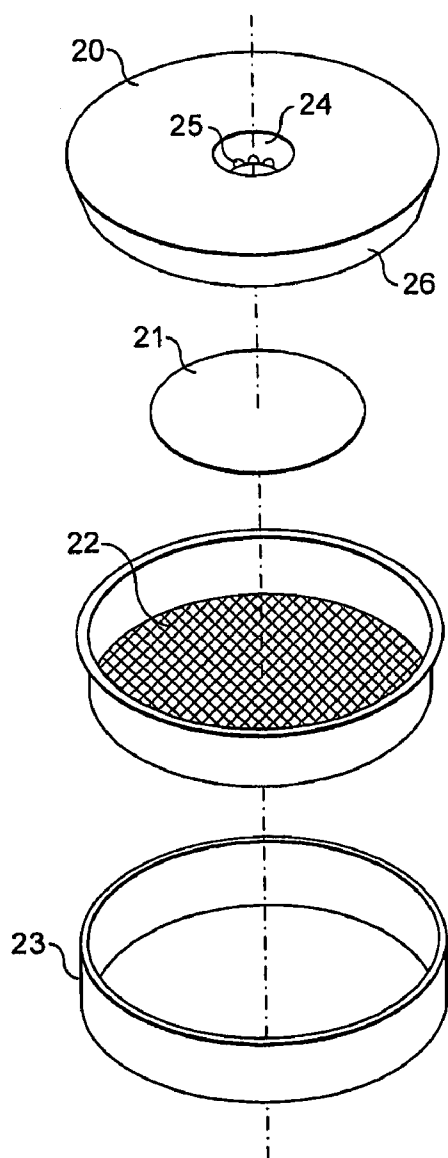

FIG. 5

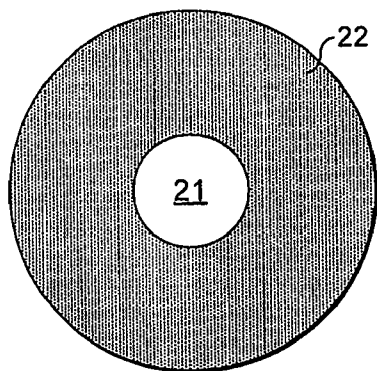

FIG. 6a

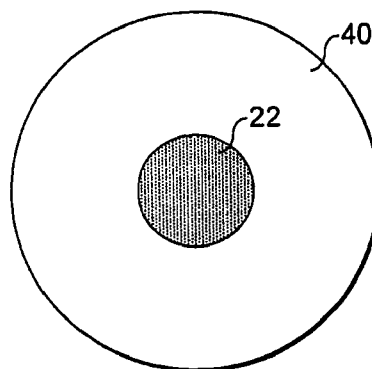

FIG. 6b

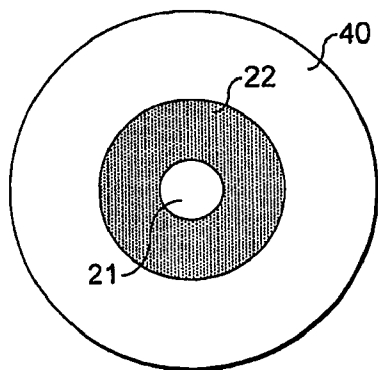

FIG. 6c

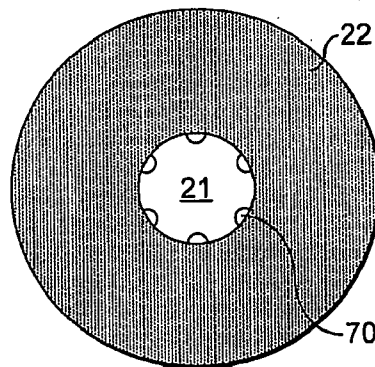

FIG. 6d

POD FOR PREPARING A BEVERAGE

[0001] The present invention relates to improvements in pods for preparing beverages which contain a water soluble substance. The water soluble substance may be a powdered ingredient for making a beverage such as coffee, tea or soup, fruit juice and desserts. The invention finds particular advantage where the water soluble substance is a milk powder or creamer powder. The pods are also known as pads, cartridges, capsules, pouches and bags.

[0002] It is known to provide pods, in particular flexible pads, for use with beverage preparation machines which contain a water soluble substance such as a creamer powder. An example of a known pad is shown in FIGS. 1 and 2. The pad 10 is simple in construction and comprises a circular upper sheet 11 and a circular lower sheet 12 of filter material which are bonded together around a peripheral seam 15 to define and seal a storage volume 13 in which the water soluble substance 14 is contained. In use, the pad 10 is placed in a beverage preparation machine such as a coffee brewer and heated water is passed through the pad 10. The heated water flows through the upper sheet 11 and lower sheet 12 of filter material and in so doing contacts and dissolves the water soluble substance 14 contained in the storage volume 13 to form the beverage. The beverage then passes through the lower sheet 12 of the filter material and is dispensed into a suitable receptacle. The water soluble substance may be used to form the whole or part of a beverage. Where the water soluble substance is a milk powder or creamer powder, the pad may be used to form a milk-based beverage or to form a milk-based portion of an alternative beverage such as coffee.

[0003] Pads with creamer powders or milk based products may be used in dispensing cappuccino-style beverages. Such pads may be used in the beverage preparation machine on their own to dispense a milky, creamy or frothy beverage portion onto an already dispensed beverage, such as coffee. Alternatively, the pad containing the creamer powder or milk-based substance may be used in the beverage preparation machine in combination with a pad containing a substance for producing another beverage portion as taught in EP0756844. For example, two pads may be used at the same time in the machine, one pad containing a creamer powder and one pad containing roast and ground coffee. In this way, a complete beverage may be dispensed in one operation cycle of the beverage preparation machine.

[0004] The pads described above are similar to well known tea bags which are used for infusing hot water with tea leaves. However, there are a number of particular problems in using such flexible pads in beverage preparation machines where the pads contain a water soluble product such as a milk powder or creamer powder as opposed to a product which is infused in water but is not itself dissolved, such as roast and ground coffee or tea leaves. One disadvantage is that as the water soluble substance 14 is dissolved by the water passing through the pad, the pad tends to collapse in on itself bringing the upper sheet 11 and lower sheet 12 of filter material into contact with one another. In addition, because the dissolution of the water soluble substance 14 is not necessarily uniform throughout the storage volume of the pad 10 during use this can lead to portions of the filter material collapsing before the whole or a substantially part of the water soluble substance 14 has been dissolved. Where the upper sheet 11 and the lower sheet 12 of filter material contact one another, there is formed

a low resistance flow path for the heated water. As a result, as soon as the pad 10 starts to collapse, the heated water has a tendency to flow through the portions of the pad 10 where the upper sheet 11 and lower sheet 12 are in contact rather than flowing more uniformly through the entire storage volume of the pad 10. This problem is exacerbated where the pad is used in a beverage preparation machine together with another pad containing another beverage portion as described above. It is preferred in such one-step dispensing of a beverage that the pad containing the infusible substance such as roast and ground coffee is placed on top of the pad containing the water soluble product so as to ensure proper extraction of the infusible substance as taught in EP0756844. However, the additional weight of the pad containing the infusible substance increases the likelihood that the pad containing the water soluble substance will collapse during the dispense cycle. For these reasons, use of pads such as those shown in FIGS. 1 and 2 can lead to substantial portions of the water soluble substance 14 being left within the pad 10 after the beverage preparation machine has completed its dispense cycle. Experiments show that for commonly used creamer powders as much as 40 to 60% of the creamer powder remains in the pad at the end of the dispense cycle. (The actual amount left depends to some extent on the dissolution properties of the creamer powder. Typically, the rate of flow of water is such that the beverage is prepared in under one minute in some machines. It is known with some compositions to include filler agents such as lactose. This results in poorer dissolution of the composition and an increased amount remaining in the pad after use. In contrast, the dissolution properties can be improved by use of agents such as surfactants. However, use of such agents has been found to result in only limited reduction in the amount of the substance left in the pad after use.) This disadvantage can lead to a beverage or beverage portion being dispensed which is weaker than intended and also leads to wastage of the water soluble substance 14. Weak beverages can also be dispensed where the ingredients or part of the ingredients are by-passed by part of the water flow during dispensation.

[0005] Attempts have been made to overcome this problem by providing a form-retaining stiffening body within the interior of the storage volume 13. EP1398279 discloses use of a form-providing stiffening body comprising a grid structure that itself comprises a compartmenting wall configuration that spans between the upper and lower sheets of the flexible pad. Whilst the form-providing stiffening body prevents collapse of the pad and contact of the upper sheet and lower sheet of filter material, the structure described is complex and increases the cost and complexity of manufacture compared to the simpler pad as shown in FIGS. 1 and 2. In addition, the compartmenting wall configuration of the pad necessitates more careful filling of the storage volume with the water soluble substance to ensure consistent filling of the compartments.

[0006] Another disadvantage with the simple flexible pads of FIGS. 1 and 2 and the pad of EP1398279 is that, after use, the pad is left in a very wet state which is unpleasant for a user to handle when removing the pad manually from the beverage preparation machine. This can lead to dripping and soiling of the machine and surroundings as the pad is transported to a waste receptacle.

[0007] A further disadvantage of the known pads and the pads of EP1398279 is that, because substantial quantities of the water soluble substance can typically be left within the

pad even at the end of a dispense cycle, the pad-holding section of the beverage preparation machine is left in a soiled state which is contaminated with beverage. As a result, the machine must be cleaned before a next beverage can be hygienically dispensed. The cleaning either involves manually disassembling the beverage preparation machine and washing the parts or by running another dispense cycle with no pad within the pad holding section so as to flush the beverage preparation machine. Both of these methods involve extra time and inconvenience to the user.

[0008] It is an object of the present invention to provide a pod which helps to alleviate these disadvantages.

[0009] Accordingly, the present invention provides a pod for preparing a beverage comprising:

[0010] a rigid or semi-rigid sidewall;

[0011] a rigid or semi-rigid upper surface containing one or more apertures forming an inlet of the pod;

[0012] a lower surface formed at least partially from filtering material, the filtering material forming an outlet of the pod;

[0013] the sidewall, upper surface and lower surface together defining a storage volume extending from the inlet to the outlet and containing a water-soluble composition, or a combination or mixture of water-soluble compositions for forming a beverage;

[0014] wherein the rigid or semi-rigid sidewall maintains a physical separation of the filtering material and the upper surface during use.

[0015] An advantage of the pod of the present invention is that the rigid or semi-rigid upper surface and side wall provide the pod as a whole with sufficient rigidity to make it easier to handle after use. In particular, the rigid or semi-rigid nature of the pod ensures that the spatial relationship of the inlet apertures is substantially maintained during use of the pod whilst the optional semi-flexible nature of the pod as a whole allows the pod to at least partially mould itself to the shape of a pod holder of a beverage preparation machine resulting in an improved fit and less chance of water by-pass in use. Further, the rigid or semi-rigid side wall advantageously acts to hold the layer of filtering material at the lowermost surface of the pod out of contact with the upper surface. This ensures that the storage volume within the pod remains as a single unitary volume during use which improves the circulation of water in the pod and also the dissolution of the water soluble substance.

[0016] The inlet of the pod may be located at or near a centre of the upper surface.

[0017] Alternatively, the inlet of the pod may be located at or near a periphery of the upper surface.

[0018] Alternatively, the apertures of the inlet may be located in at least two discrete regions of the upper surface. Optionally, a portion of the apertures of the inlet are located at or near a centre of the upper surface and a portion of the apertures of the inlet are located at or near a periphery of the upper surface.

[0019] The apertures of the inlet may be arranged randomly across at least a portion of the upper surface. Alternatively, the apertures of the inlet may be arranged uniformly across at least a portion of the upper surface.

[0020] Preferably, the inlet of the pod is recessed below a remainder of the upper surface. Preferably, the upper surface comprises one or more cylindrical or frusto-conical recesses and the inlet is formed at or near a base of said recesses. Recessing the inlet of the pod below the remainder of the

upper surface allows the inlet apertures to be positioned within the bulk of the water soluble composition. As a result, the flow and jetting of the water through the inlet apertures into the storage volume takes place within the centre of the water soluble composition resulting in turbulence, better mixing, and improved dissolution of the composition. In addition, recessing the inlet apertures below the upper surface helps to prevent the apertures being blocked in the eventuality that an object that rests in use on the upper surface of the pod. For example, it may be desired to use the pod in combination with a pad containing roast and ground coffee in a one step beverage dispense cycle as described above. In this case the pad, which would typically be a flexible pad similar to that shown in FIGS. 1 and 2, would rest on the upper surface of the pod. Any sagging or distortion of the flexible pad during dispensing would not result in the inlet apertures of the pod being blocked as the recess would maintain a physical separation of the pad and the apertures.

[0021] The inlet may comprise 1 to 100 apertures, preferably 1 to 63 apertures, alternatively 5 to 30, or 10 to 20 apertures.

[0022] At least some of the apertures may be directed radially outwards towards the sidewall of the pod. At least some of the apertures may direct flow of water there through to impact a sidewall of the pod. At least some of the apertures may direct flow of water there through to impact one or more baffles within the pod.

[0023] At least some of the apertures may be directed radially inwards towards a centre of the pod.

[0024] At least some of the apertures may be directed tangentially relative to the recess. At least some of the apertures may be directed parallel to the upper surface of the pod. At least some of the apertures may be directed upwards towards the upper surface of the pod. At least some of the apertures may be directed downwards away from the upper surface of the pod.

[0025] A cage may be provided having a series of apertures that provides an upwardly angled flow of water as the water enters the storage volume. The cage may span between the upper and lower faces of the pod and so also act as a support for the filtering material of the lower surface. The apertures in the cage may be positioned part way up the cage such that water entering the cage is forced into a turbulent motion before passing through the apertures of the cage into the storage volume. Suitable angling of the apertures of the inlet can improve the distribution and circulation of the water within the storage volume during use and hence the dissolution of the water soluble composition. In particular, angling the apertures upwards towards the upper surface, radially towards the side wall and downwardly towards the lower surface ensures that the water reaches all parts of the storage volume. All of the apertures of the inlet may be similarly angled. Alternatively the apertures may have a combination of angles such that some are directed upwards, some radially, some tangentially and some downwardly. It will be clear that various combinations both regular and random can be achieved to produce differing flow patterns within the storage volume.

[0026] The apertures may be circular or of other shape such as square or be in the form of slits. Preferably, the apertures have an equivalent diameter of 0.1 mm to 5.0 mm. Preferably, the apertures have an equivalent diameter of 0.3 mm to 0.7 mm and in particular 0.5 mm where there are 12 apertures. The sidewall may be formed integrally with the upper surface. Alternatively, the upper surface may comprise a downwardly

dependent skirt and the sidewall may be conjoined with the upper surface by engagement of the sidewall with the downwardly dependent skirt. Preferably, the engagement is by means of friction and/or a physical seal. Use of a side wall which engages, by means of friction and/or a seal, a downwardly dependent skirt of the upper surface provides a simple construction for the pod. In particular, sufficient friction is generated that no adhesive or mechanical connection is required between the upper surface and the side wall. It will be appreciated that in use when inserted in the beverage preparation machine, pressure will be applied to the upper surface and lower surface of the pod by the closure mechanism of the beverage preparation machine which will tend to hold together the components of the pod and prevent separation during use.

[0027] Advantageously, a periphery of the filtering material may be sandwiched between the sidewall and the downwardly dependent skirt. Again, sandwiching the filter material between the side wall and the downwardly dependent skirt provides a simple and effective mechanism for constructing the pod which removes the need for adhesive or other bonding techniques. Alternatively, the filtering material may be bonded by any of the techniques known in the art, including but not limited to heat sealing, induction sealing, ultrasonic sealing or adhesive to a bottom edge or side of the sidewall.

[0028] In one embodiment the whole of the lower surface is formed from filtering material. Alternatively, a portion of the lower surface may be non-transmissive to water and another portion may be formed from the filtering material. In one option, the portion of filtering material is located at or near a centre of the lower surface. In another option the portion of filtering material forms an annulus at a defined radius from the centre of the pod. In a further option the portion of filtering paper forms the outer periphery of the lower surface and the centre of the lower surface is non-transmissive. By forming the lower surface with only a portion being formed from filtering material can improve dissolution by channelling the outward flow from the storage volume to a central portion of the pod.

[0029] The height of the pod from the upper surface to the lower surface may be between 2 mm and 50 mm. Preferably, the height of the pod is 5 mm to 7 mm when dispensing a beverage or beverage portion of 100 to 150 ml and 14 to 16 mm when dispensing a beverage or beverage portion of greater than 180 ml and greater than 20 mm when dispensing a beverage of greater than 240 ml. Different height pods can be used to accommodate different volumes of water soluble composition as dictated by the needs for the type of beverage dispensed. For example the desired strength of the beverage and the strength of the beverage ingredients will also affect the required height of the pod.

[0030] The upper surface and/or sidewall may comprise at least one air vent or one way valve. The upper surface and/or sidewall may comprise at least one weakened or frangible area which, during use, is rupturable to form an air vent. The use of a vent in the upper surface or side wall of the pod improves the purging of the pod towards the end of the dispense cycle. In particular an increased air flow through the pod helps to drive or drain out any remaining moisture.

[0031] In a preferred embodiment the storage volume further contains a dispersion plate associated with the outlet for creating a non-vertical flow of water, in use, within the storage volume. Preferably the dispersion plate is freely sus-

ended within the storage volume. Alternatively, the dispersion plate is attached to the filtering material of the outlet. Alternatively, the dispersion plate forms part of the lower surface. Alternatively the dispersion plate could be fixed to the body.

[0032] The dispersion plate may be planar, rippled, ridged or otherwise convoluted. The dispersion plate may be non-apertured or comprise one or more apertures. The dispersion plate may be sealed or bonded to the lower surface and the one or more apertures may be formed at the boundary between the dispersion disc and the outlet filtering means.

[0033] The dispersion plate may form part of an outlet filtering means. The dispersion plate may comprise a portion of the outlet filtering means which has modified material characteristics and is non-transmissive to water. For example, the outlet filtering means may comprise a filter paper and the dispersion plate may comprise a portion of the filter paper which is hot stamped to render it impermeable to water.

[0034] The dispersion plate may be attached to an outer face of the lower surface. There may be more than one dispersion plate.

[0035] The pod may be circular with a diameter of between 30 and 110 mm. Preferred diameters are between 60 and 70 mm, between 30 and 40 mm and between 100 and 110 mm. The diameter of the pod will depend on the nature of the beverage preparation machine for use with the pods. The storage volume may further contain one or more absorbent elements or particles or foamed plastic elements or particles. The absorbent elements or particles may be spongiform material or a hydrogel. The spongiform elements or particles may be any suitable material which possesses the porous and water-retaining characteristics of a sponge. For example, compressed sponge or natural sponge. Dried seaweed can form a suitable alternative material. Preferably, before exposure to liquid, the one or more spongiform elements or particles or foamed plastic elements or particles are compressed. By using a compressed form the dimensions and volume of the spongiform particles or elements before dispensing may be minimised. This helps to reduce the overall size of the pads allowing for smaller packages of pads to be produced. The compressed sponge exhibits good expansion behaviour in contact with water and has good water absorbency in the expanded state. The sponge is stable and is of food grade quality which is suitable for storing in contact with beverage ingredients.

[0036] In one embodiment the one or more absorbent elements or particles interact with water in use such as to absorb water only during a portion of a dispense cycle. For example, the one or more absorbent elements or particles may interact with water at a predetermined temperature, pH or a start of a specified chemical reaction. Preferably, the one or more absorbent elements or particles comprise a soluble coating which, in use, is dissolvable in water to allow absorption of water to take place. For example, the soluble coating may comprise sugar or gelatine.

[0037] The one or more absorbent elements or particles may comprise one or more or compressed sponge, natural sponges, dried seaweed, poly (HEMA) 2 hydroxyethyl methacrylate, polyacrylic, polyacrylamide, Gelatine, Alginate, Agar and Carrageenan, and other hydrocolloids.

[0038] Preferably, in use, the one or more absorbent elements act as an absorbent means for retaining excess moisture. The water retaining properties of the spongiform or hydrogel particles or elements help to retain the majority of

any excess water that is left within the pad after the end of the dispense cycle. As a result the user may pick up the used pod and remove it to a waste receptacle with less soiling or dripping. In addition, the water absorbency of the spongiform or hydrogel particles or elements means that less liquid is left in the pod holding section of the beverage preparation machine. As a consequence, cleaning of the machine is made easier.

[0039] The pod may contain a single spongiform or hydrogel element.

[0040] Preferably the water-soluble composition is agglomerated. The agglomerated water-soluble composition may be produced by contacting the water-soluble composition with steam, water, or aqueous solution or dispersion to effect agglomeration, and optionally, either simultaneously or subsequently drying the agglomerated composition. Agglomerating the powder significantly increases the efficiency of dissolving the powder. In a comparison test, the amount of powder residue left in a standard pad was reduced from 50% to 35% when using an agglomerated powder rather than a non-agglomerated powder.

[0041] For the purposes of the present invention, water-soluble substances or compositions are defined as substances which wholly or substantially dissolve in the presence of a solvent which will typically be water. The ingredient composition of the substance before and after dissolution is substantially the same (excluding the diluting effect of the solvent). Thus, water-soluble substances exclude infusible substances such as roast and ground coffee and leaf tea. With infusible substances the ingredient composition of the infusion is substantially different to the ingredient composition of the infusible or extractable precursor since the infusion only contains certain flavour and/or aromatic qualities of the infusible substance. Examples of water-soluble substances according to the present invention include compositions such as milk powder, creamer powder, instant whitener, instant coffee, instant tea, instant soup, instant chocolate drink, sugar, instant fruit juice and instant dessert powders.

[0042] The water-soluble composition may be a milk powder or creamer powder or chocolate powder. For example, the milk powder or creamer powder may be a dairy or non-dairy spray-dried coffee creamer or coffee whitener. The fat component of the milk powder or creamer powder may have a melting point of 10 to 40 degrees Celsius.

[0043] The creamer powder may comprise one or more of vegetable fat, milk proteins, emulsifiers, stabilisers, foaming agents, milk fat, soy proteins, modified starches, carriers, fillers, sweeteners, flavours, colours, nutrients, preservatives and flow agents.

[0044] In one embodiment the pod further comprises one or more channels or grooves in the upper surface, said channels or grooves extending towards the inlet. Preferably, the channels or grooves cover the upper surface and extend from the edge to the centre. The channels may have a depth of 1 to 2 mm and a width of 1 to 3 mm. Preferably, the channels and grooves extend radially towards a central inlet, or where there the apertures of the inlet are in more than one location towards the apertures. The channels or grooves assist in flow of water to the inlet of the pod is use. This is particularly advantageous when the pod is used in a one step procedure where a flexible pad is placed on top of the pod. The grooves or channels ensure that the water can pass through extractable material that may be placed above the pod, thus significantly improving extraction efficiency. Additionally, the grooves or channels ensure that the water can pass into the inlet of the pod

without becoming blocked by sagging or distortion of the filtering material of the flexible pad. Rather than channels or grooves, vertical struts, pyramid structures or similar may be used to raise the filtering material of a pad off the upper surface.

[0045] The inlet may overlaid with a bar or grid structure that prevents a pad placed on top of the inlet region from sagging into contact with the inlet apertures.

In one embodiment the pod further comprises further comprises means at or near the outlet for foaming the beverage. This allows for foaming of the beverage which is particularly desirable where the beverage is a creamer powder. In one option, the means for foaming the beverage is an aperture for forming a jet of beverage and subsequently impacting said jet of beverage against an impingement surface so as to produce foaming of the beverage. The means for foaming the beverage may be an eductor or venturi ejector for forming a jet of beverage and including gas into the beverage jet as taught in EP1255685.

[0046] In another option, the means for foaming the beverage comprises a sintered outlet nozzle, or zeolite bed or membrane.

[0047] The pod may comprise a gasket seal on or adjacent the upper surface for sealing, in use, against a pod holder of a beverage preparation machine in which the pod is used.

[0048] The pod may comprise a peripheral seal on an outer surface of the sidewall for sealing, in use, against a pod holder of a beverage preparation machine in which the pod is used.

[0049] The pod may comprise a seal on or adjacent a lower edge of the sidewall for sealing, in use, against a pod holder of a beverage preparation machine in which the pod is used.

[0050] These seals allow for improved water flow through the pods by limiting or eliminating water by-pass in the pod holder of the beverage preparation machine. In this way a consistent strength of beverage is produced. Also, the seal can be made of an absorbent material which helps to remove excess moisture from the pod holder of the beverage machine after use.

[0051] The storage volume may be a unitary volume. Alternatively, the storage volume may comprise a plurality of compartments. In that case, the plurality of compartments may comprise different beverage ingredients and one or more of the compartments may contain one or more absorbent elements or particles or foamed plastic elements or particles.

[0052] In an alternative embodiment, the one or more apertures forming the inlet to the pod are formed in the sidewall rather than the upper surface.

[0053] The apertures may be circular, square or slits or other geometric shapes.

[0054] The storage volume may comprise one or more baffles to aid water distribution and flow within the pod.

[0055] The present invention also provides a beverage brewing kit comprising a first pod as described above in combination with a flexible filter pad containing one or more beverage ingredients suitable for brewing. The flexible filter pad may contain roast and ground coffee. Optionally, the pod and pad are joined prior to use. Preferably, the pod and pad are overwrapped and sealed between two pieces of filter paper to form a single item.

[0056] The present invention further provides a water-soluble composition of a milk powder or creamer powder containing a plurality of dispersed absorbent particles.

[0057] The present invention further provides a method of dispensing a beverage using a pod as described above com-

prising the step of passing water downwardly through the pod such that beverage initially exits the pod through a lowermost surface thereof.

[0058] Alternatively water may pass upwardly through the pod such that beverage initially exits the pod through an uppermost surface thereof.

[0059] Alternatively the pod may be orientated in a non-horizontal orientation and water passed in a vertical or non-vertical direction through the pod.

[0060] Flow of water through the pod may be substantially parallel to a major axis of the pod or substantially cross-ways to a major axis of the pod or in a direction part-way between parallel flow and cross flow.

[0061] Water may be passed through the pod at a temperature greater than 70 degrees Celsius.

[0062] Water may be passed through the pod as a discontinuous flow. Preferably as a pulsed flow.

[0063] A beverage is prepared using the pods of the present invention by inserting the pods in a beverage preparation machine. The pods may be used in a variety of beverage preparation machines. In one example, the beverage preparation machine generally comprises a housing containing a water heater, a water pump, optionally an air compressor, a control processor, a user interface and a head. The head in turn generally comprises a holder for holding, in use, the pod or pods. The beverage preparation machine is also provided with a water tank.

[0064] The housing comprises a dispense station where dispensation of the beverage takes place. The dispense station comprises a receptacle stand having a hollow interior forming a drip tray.

[0065] The head is located towards the top of the housing above the receptacle stand. The holder of the head is shaped to receive the pod of the present invention and to hold the pod in the correct orientation such that water may be passed through the pod. Preferably the holder and head are provided with sealing means for sealing around a periphery of the pod to prevent by-pass flow of water in use. The head may be designed to direct flow of water downwardly through the pod so that beverage exits the pod through a lowermost surface of the pod. Alternatively, the head may be designed to direct flow of water upwardly through the pod so that beverage initially exits the pod through an uppermost surface of the pod before being ultimately directed downwardly to a receptacle. Of course the pod may be used in an orientation other than horizontal, for example, in a vertical orientation. The pod may also be inverted such that the surface described as a lower surface above is uppermost in the pod holder of the beverage preparation machine.

[0066] The user interface is located on the front of the housing and comprises a start/stop button, and a plurality of status indicators.

[0067] The start/stop button controls commencement of the operating cycle and is a manually operated push-button, switch or similar.

[0068] The water tank is located to the rear of the housing and is connected in use to a water tank station located at a rear half of the housing.

[0069] The water pump is operatively connected between the water tank and the water heater and is controlled by the control processor.

[0070] The water heater is located in the interior of the housing. The heater is able to heat water received from the

water pump from a starting temperature of approximately 20° C. to an operating temperature of around 85° C. in under 1 minute.

[0071] The control processor of the beverage preparation machine comprises a processing module and a memory. The control processor is operatively connected to, and controls operation of, the water heater, water pump, air compressor and user interface.

[0072] Embodiments of the present invention will now be described, by way of example, with reference to the accompanying drawings in which:

[0073] FIG. 1 is an upper plan view of a prior art flexible pad;

[0074] FIG. 2 is a cross-sectional view of the flexible pad of FIG. 1;

[0075] FIG. 3 is a perspective view of a pod according to the present invention in assembled form;

[0076] FIG. 4 is a cross-sectional view of the pod of FIG. 3;

[0077] FIG. 5 is an exploded perspective view of the pod of FIG. 3; and

[0078] FIGS. 6a to 6d show lower plan views of alternative embodiments of pod according to the present invention.

[0079] FIGS. 3 to 5 illustrate a pod according to the present invention. The pod comprises a rigid or semi-rigid upper element 20 or a combination of a rigid or semi-rigid element with a foiled material or other flexible thin sheet water impermeable material. The upper element has a planar upper surface 27 with a centrally located recess 24. The base of the recess 24 is provided with six apertures 25. The upper element 20 further comprises a downwardly dependent skirt 26 which is cylindrical in form and open-ended at a lower end thereof. A rigid or semi-rigid sealing ring 23 is provided which defines a side wall of the pod 10. The sealing ring 23 is frictionally engagable with the downwardly dependent skirt 26 of the upper element 20. During assembly of the pod 10, a layer of filtering material 22 is stretched across the open end of the downwardly dependent skirt 26 and the sealing ring 23 is engaged with the upper element 20 so as to sandwich the layer of filtering material 22 between the sealing ring 23 and an outer surface of the downwardly dependent skirt 26 as shown in FIG. 4. Assembly of the pod 10 in this manner stretches the layer of filtering material 22 across the rim of the downwardly dependent skirt 26 so as to form a lower surface 28 of the pod. The frictional engagement of the sealing ring 23 and the downwardly dependent skirt 26 retains the layer of filtering material 22 securely. In an alternative method, the filtering material can be bonded by heat or adhesive to the downwardly dependent skirt 26.

[0080] As shown in FIG. 4, a storage volume 31 is defined in the pod 10 by the upper element 20, the layer of the filtering material 22 and the side wall of the sealing ring 23. The storage volume 31 contains a volume of a water soluble composition 30. The invention finds particular application where the water soluble substance 14 is a milk powder or creamer powder. Milk powders include dried skimmed milk, part-skimmed milk, and whole milk, dried milk protein concentrates, isolates, and fractions, or any combination thereof. Creamer powders can be manufactured from dairy and/or non-dairy food ingredients and typically contain emulsified fat, stabilized by protein or modified starch, dispersed in a carrier that facilitates drying, especially spray drying. Optional ingredients include buffers, flavours, colours, fillers, sweeteners, foaming agents, flow agents, nutrients, preservatives, and the like. Milk powders and creamer powders are

particularly useful as coffee whiteners for brewed, soluble, and flavoured coffee products, including latte and cappuccino. In the following description, for example only, the water soluble substance will be described as a creamer powder unless the context otherwise requires.

[0081] The creamer powder may for example comprise the following by weight:

| | |
|--|-------|
| Hardened vegetable fat | 49% |
| Glucose syrup | 41% |
| Sodium Caseinate | 4.5% |
| Polyphosphates - K ₂ HPO ₄ | 2.0% |
| Na-Polyphosphate | 2.5% |
| Silicon dioxide | 0.25% |
| Emulsifier (Sodium stearoyl-2-lactylate) | 0.75% |

[0082] Other compositions may be used which contain fillers such as lactose and additional stabilisers or other ingredients such as milk powder, flavourings, sweeteners. Additional emulsifiers may be added to improve wetting. Advantageously, the creamer may be provided in an agglomerated form to assist and improve solubility. Advantageously, the creamer powder may comprise a low melting temperature fat having a melting temperature of between 10 and 40 degrees Celsius. Some or all of the fat content of the composition noted above may be substituted for low melting temperature fat. In one example the composition comprises 24% low melting temperature fat and 25% fat with a melting temperature of above 40 degrees Celsius. This results in a reduction of creamer powder residue in the pod of around 15 to 20%.

[0083] The storage volume **31** is also provided with a dispersion disc **21** which is freely moveable within the storage volume **31**. As shown in FIG. 4, the dispersion disc **21** is located towards the bottom of the storage volume **31** in contact with the filtering material **22**. However, the dispersion disc **21** may be located within the bulk of the creamer powder or on top of the creamer powder. Indeed, in use, the dispersion disc **21** will tend to move somewhat within the interior of the storage volume **31**. Alternatively, the dispersion disc **21** may be bonded to, attached to, or form part of the outlet filtering means.

[0084] The upper element **20**, sealing ring **23** and dispersion disc **21** are all formed from a rigid or semi-rigid material such as polypropylene, polyester, polystyrene, nylon, polyurethane, other engineering plastics, composites, metal, metal-plastic composites, card, wood, rubber or biodegradable plastics such as degradable polyethylene (for example, SPITEK supplied by Symphony Environmental, Borehamwood, United Kingdom), biodegradable polyester amide (for example, BAK 1095 supplied by Symphony Environmental), poly lactic acids (PLA supplied by Cargil, Minnesota, USA), starch-based polymers, cellulose derivatives and polypeptides. The material may be thermoformed, compression moulded or injection moulded.

[0085] In use, the pod **10** is placed in a suitable beverage preparation machine and water is passed through the pod **10**. The water enters the storage volume **31** through the inlet apertures **25** at the base of the recess **24**. In the embodiments shown, the apertures **25** are angled so as to direct jets of water radially towards the side wall **23** of the pod **10**. The water circulates within the unitary storage volume **31** of the pod **10** dissolving the creamer powder to form the beverage. The beverage is then able to pass through the layer of filtering

material **22** at a lower surface **28** of the pod **10** and out of the beverage preparation machine.

[0086] After use, the user of the beverage preparation machine may remove the pod **10** and dispose of it in a waste receptacle. Advantageously, the rigidity of the pod **10** imparted by the rigid or semi-rigid upper element **20** and side wall of the sealing ring **23** makes for easier handling of the pod **10** compared to the prior art pad of FIGS. 1 and 2.

[0087] With the pod **10** of FIGS. 3 to 5 the amount of creamer residue remaining within the storage volume **31** was reduced to around 1 to 10%.

[0088] In a non-illustrated embodiment, the storage volume **31** also contains a spongiform element or foamed plastics element in the form of a circular disc of compressed sponge material. The disc has preferred diameters of 100 to 100 mm, 50 to 59 mm and 30 to 40 mm and a thickness of 3 mm. The disc is formed from cellulose sponge such as that manufactured by 3M. Other suitable materials for the spongiform element include other food grade materials with similar physical properties to those of cellulose sponge in terms of there porosity and or expandability.

[0089] Prior to use of the pod, the pod and its contents are dry. If necessary, the pod can be supplied in an hermetically sealed package to prevent moisture ingress or absorption.

[0090] The compressed sponge or foamed plastic disc may be positioned on top of the creamer powder within the storage chamber **31**. Alternatively, the compressed sponge or foamed plastic may be positioned underneath the creamer powder or within the mass of the creamer powder.

[0091] In use, the pod is used as described above. On contact with the water, the compressed sponge rapidly expands. In the expanded state the disc has a thickness of between 10 and 20 mm, preferably around 15 mm. Thus, the action of the liquid on the compressed sponge is to produce an expansion in the thickness of the compressed sponge of around 500%. The compressed sponge may be configured to expand generally only in one dimension, i.e. its thickness, or may be configured to expand three-dimensionally, i.e. to increase its thickness and also its diameter. Water is able to pass through the expanded compressed sponge substantially unhindered. As a result, the water quickly contacts and dissolves the creamer powder to produce the milk based beverage or beverage portion. The beverage containing the dissolved creamer powder passes through the lower filter layer **22** and out of the beverage preparation machine.

[0092] Advantageously, the porous water-retaining nature of the spongiform element helps to retain excess moisture that may be within the pod. The capillary action of the pores of the spongiform element help to prevent dripping from the pod as it is transferred to a waste receptacle. In addition, the water-retaining nature of the spongiform element has the consequence that the pod holding section of the beverage preparation machine contains less free moisture and hence less contamination than compared with the use of prior art pads. As a result the machine is easier to clean and prepare in readiness for the next dispense cycle. In the above the pod has been described as containing spherical spongiform particles. However, the particles may take other forms such as block shapes, irregular shapes or be formed as shredded portions of a sheet material.

[0093] In an alternative, non-illustrated embodiment, the storage volume **31** also contains a plurality of absorbent particles in the form of particles of compressed sponge material. The particles **20** each a size (diameter or length) of 1 to 10 mm

and a thickness of 1 to 3 mm before use. The particles **20** are formed from compressed cellulose sponge.

[0094] Preferably the ratio by weight of the creamer powder to the absorbent particles before use is from 20:1 to 2:1, preferably around 3:1.

[0095] The compressed sponge particles are dispersed throughout the creamer powder within the storage chamber. The particles may be roughly spherical or of other suitable shapes such as rods, tubes, strips, etc.

[0096] In use, the pod is used as described above. On contact with the water, the compressed particles rapidly expand. In the expanded state the particles have a thickness of around 15 mm. The diameter of the particles is not substantially changed, i.e. the expansion is uni-directional. Thus, the action of the liquid on the compressed sponge is to produce an expansion in the compressed sponge of around 500%. Water is able to pass through the expanded sponge substantially unhindered. As a result, the water quickly contacts and dissolves the creamer powder to produce the milk based beverage or beverage portion. The beverage containing the dissolved creamer powder passes through the filter material **22** and out of the beverage preparation machine.

[0097] Advantageously, the porous water-retaining nature of the spongiform particles helps to retain excess moisture that may be within the pod. The capillary action of the pores of the spongiform particles help to prevent dripping from the pad as it is transferred to a waste receptacle. In addition, the water-retaining nature of the spongiform particles has the consequence that the pad holding section of the beverage preparation machine contains less moisture and hence less contamination than compared with the use of prior art pads. As a result the machine is easier to clean and prepare in readiness for the next dispense cycle.

[0098] In another, non-illustrated, embodiment, the spongiform particles are replaced by particles of a hydrogel substance in the form of spherical or otherwise shaped particles. In use, and on contact with water, the hydrogel absorbs water and expands. The expansion of the hydrogel particles aids dissolution of the creamer powder. Advantageously, the intake of water by the hydrogel is rapid and results in the hydrogels absorbing preferentially water rather than dissolved creamer powder.

[0099] Utilising absorbent elements or particles as described above with the pod of FIGS. **3** to **5** has been shown to substantially eliminate creamer residue and liquid from the storage volume after use.

[0100] The pods of the present invention may also comprise one or more seals to allow for improved engagement of the pod with a pod holder of the beverage preparation machine. Seals may be provided on or adjacent the upper surface, on an outer surface of the sidewall, and on or adjacent a lower edge of the sidewall. The seals may be separate or part of the body. The seals help to prevent water by-pass by reducing or eliminating the quantity of water that does not pass through the pod.

[0101] The pods of the present invention may also be provided with an aperture at or near the outlet through which the beverage is forced to form a jet of beverage. The jet of beverage can then be impacted against an impingement surface to create foaming of the beverage.

[0102] The pods may advantageously comprise grooves or channels on the upper surface to aid inflow of water towards the inlet apertures **25**. The grooves or channels are preferably linear and, in the case of a central inlet recess **24**, radially

inwardly directed towards the recess **24**. The grooves or channels are preferably 1 to 2 mm in depth so as to prevent blockage when the pod is used together with a flexible pad in a one step dispense cycle.

[0103] FIGS. **6a** to **6d** illustrate alternative layouts for the lower surface **28** of the pod. In FIG. **6a**, the lower surface **28** is formed of the filter material **22** except for a central region which is non-transmissive to water. The central region may be in the form of the dispersion disc **21** described above and formed as part of the lower surface **28**. In FIG. **6b** the filter material **22** forms the central region of the lower surface **28** and the periphery **40** is non-transmissive. In FIG. **6c** the filter material **22** forms an annulus with central **21** and outer periphery **40** regions being non-transmissive. These arrangements can be used to channel flow of water and beverage through the pod. In FIG. **6d** the arrangement is as in FIG. **6a** except that the dispersion disc **21** comprises a plurality of apertures **70** at the boundary between the disc and the filter material **22** to allow through flow of water. In this version, the filter material **22** could be replaced with a non-transmissive material such that all water flow was through the apertures **70**.

[0104] In the above description, the storage chamber **31** has been described as a unitary volume. However, the volume may be separated into multiple compartments using rigid or flexible materials. The chambers may if desired contain different beverage ingredients or the same ingredients. Some or all of the compartments may comprise absorbent bodies of the types described above. Some or all of the compartments may have dispersion discs contained therein.

[0105] In the above description, the inlet apertures **25** are formed in the upper surface. However, in an alternative pod the inlets **25** may be formed in the side walls of the pod and be directed inwards towards a centre of the pod.

[0106] The water soluble substance has been described as preferably being a milk- or dairy-based creamer powder. However the pods of the present invention may also find application with other soluble ingredients such as instant coffee, instant tea, chocolate, soup or dessert ingredients. Whilst the pod has been particularly described with an inlet at the centre of the upper surface other arrangements are within the scope of the present invention. In particular the inlet recess may be formed near the periphery of the upper surface. Further, the upper surface may comprises more than one recess, each having apertures such that the inlet to the pod is distributed in at least two discrete regions of the upper surface. For example, three recesses of the form of recess **24** of FIG. **3** may be provided.

[0107] The pod may be re-useable and in this case may be provided with a removable lid in the upper surface allowing access to the storage volume to allow replenishment of the creamer powder.

[0108] The pod may be used for dispensing hot and cold beverages. Still and carbonated beverages may be produced by using still or carbonated water.

[0109] The absorbent particles may be formed from a hydrogel, starch or a mixture of one or more of spongiform, starch and hydrogel materials with a particle size of 25 microns to 10 mm.

1. A pod for preparing a beverage comprising:
 - a rigid or semi-rigid sidewall;
 - a rigid or semi-rigid upper surface containing one or more apertures forming an inlet of the pod;

- a lower surface formed at least partially from filtering material, the filtering material forming an outlet of the pod;
- the sidewall, upper surface and lower surface together defining a storage volume extending from the inlet to the outlet and containing a water-soluble composition, or a combination or mixture of water-soluble compositions for forming a beverage;
- wherein the rigid or semi-rigid sidewall maintains a physical separation of the filtering material and the upper surface during use.
2. A pod as claimed in claim 1 wherein the inlet of the pod is located at or near a centre of the upper surface.
3. A pod as claimed in claim 1 wherein the inlet of the pod is located at or near a periphery of the upper surface.
4. A pod as claimed in claim 1, wherein the apertures of the inlet are located in at least two discrete regions of the upper surface.
5. A pod as claimed in claim 4 a portion of the apertures of the inlet are located at or near a centre of the upper surface and a portion of the apertures of the inlet are located at or near a periphery of the upper surface.
6. A pod as claimed in claim 1 wherein the apertures of the inlet are arranged in a circle.
7. A pod as claimed in claim 1 wherein the apertures of the inlet are arranged randomly across at least a portion of the upper surface.
8. A pod as claimed in claim 1 wherein the apertures of the inlet are arranged uniformly across at least a portion of the upper surface.
9. A pod as claimed in claim 8 wherein the inlet of the pod is recessed below a remainder of the upper surface.
10. A pod as claimed in claim 9 wherein the upper surface comprises one or more cylindrical or frusto-conical recesses and the inlet is formed at or near a base of said recesses.
11. A pod as claimed in claim 1, wherein the inlet comprises 1 to 100 apertures.
12. A pod as claimed in claim 1, wherein the inlet comprises 1 to 63 apertures.
13. A pod as claimed in claim 1, wherein the inlet comprises 5 to 30 apertures.
14. A pod as claimed in claim 1, wherein the inlet comprises 10 to 20 apertures.
15. A pod as claimed in claim 11 wherein at least some of the apertures are directed radially outwards towards the sidewall of the pod.
16. A pod as claimed in claim 11 wherein at least some of the apertures direct flow of water there through to impact a sidewall of the pod.
17. A pod as claimed in claim 11 wherein at least some of the apertures direct flow of water there through to impact one or more baffles within the pod.
18. A pod as claimed in claim 11 wherein at least some of the apertures are directed radially inwards towards a centre of the pod.
19. A pod as claimed in claim 11 wherein at least some of the apertures are directed tangentially relative to the recess.
20. A pod as claimed in claim 11 wherein at least some of the apertures are directed parallel to the upper surface of the pod.
21. A pod as claimed in claim 11 wherein at least some of the apertures are directed upwards towards the upper surface of the pod.
22. A pod as claimed in claim 11 wherein at least some of the apertures are directed downwards away from the upper surface of the pod.
23. A pod as claimed in claim 1 wherein the apertures have an equivalent diameter of 0.1 mm to 5.0 mm.
24. A pod as claimed in claim 23 wherein the apertures have an equivalent diameter of 0.3 mm to 0.7 mm.
25. A pod as claimed in claim 1 wherein the sidewall is formed integrally with the upper surface.
26. A pod as claimed in claim 1 wherein the upper surface comprises a downwardly dependent skirt and the sidewall is conjoined with the upper surface by engagement of the sidewall with the downwardly dependent skirt.
27. A pod as claimed in claim 26 where the engagement is by means of friction.
28. A pod as claimed in claim 26 wherein a periphery of the filtering material is sandwiched between the sidewall and the downwardly dependent skirt.
29. A pod as claimed in claim 26 wherein the filtering material is bonded to a lower edge of the sidewall.
30. A pod as claimed in claim 26 where the whole of the lower surface is formed from filtering material.
31. A pod as claimed in claim 26 wherein a portion of the lower surface is non-transmissive to water and another portion is formed from the filtering material.
32. A pod as claimed in claim 31 wherein the portion of filtering material is located at or near a centre of the lower surface.
33. A pod as claimed in claim 31 wherein the portion of filtering material is an annulus located at a defined radius from the centre of the pod.
34. A pod as claimed in claim 31 wherein the portion of filtering material is at a periphery of the lower surface.
35. A pod as claimed in claim 1 wherein the height of the pod from the upper surface to the lower surface is between 2 mm and 50 mm.
36. A pod as claimed in claim 35 wherein the height of the pod is 5 mm to 7 mm.
37. A pod as claimed in claim 35 wherein the height of the pod is 7 mm to 11 mm.
38. A pod as claimed in claim 35 wherein the height of the pod is 14 mm to 16 mm.
39. A pod as claimed in claim 35 wherein the height of the pod is 20 mm to 30 mm.
40. A pod as claimed in claim 35 wherein the upper surface and/or sidewall comprises at least one air vent or one way valve.
41. A pod as claimed in claim 40 wherein the upper surface and/or sidewall comprise at least one weakened or frangible area which, during use, is rupturable to form an air vent.
42. A pod as claimed in claim 1 wherein the storage volume further contains a dispersion plate associated with the outlet for creating a non-vertical flow of water, in use, within the storage volume.
43. A pod as claimed in claim 42 wherein the dispersion plate is freely suspended within the storage volume.
44. A pod as claimed in claim 42 wherein the dispersion plate is attached to the filtering material of the outlet.
45. A pod as claimed in claim 42 wherein the dispersion plate forms part of the lower surface.
46. A pod as claimed in claim 42 wherein the dispersion plate is attached to the sidewall.
47. A pod as claimed claim 42 wherein the dispersion plate is planar.

48. A pod as claimed claim 42 wherein the dispersion plate is rippled, ridged or otherwise convoluted.

49. A pod as claimed claim 42 wherein the dispersion plate is non-apertured.

50. A pod as claimed claim 42 wherein the dispersion plate comprises one or more apertures.

51. A pod as claimed in claim 50 wherein the dispersion plate is sealed or bonded to the lower surface and the one or more apertures are formed at the boundary between the dispersion plate and the outlet filtering means.

52. A pod as claimed 51 claim 51 wherein the dispersion plate forms part of an outlet filtering means.

53. A pod as claimed in claim 52 wherein the dispersion plate comprises a portion of the outlet filtering means which has modified material characteristics and is non-transmissive to water.

54. A pod as claimed in claim 53 wherein the outlet filtering means comprises a filter paper and the dispersion plate comprises a portion of the filter paper which is hot stamped to render it impermeable to water.

55. A pod as claimed in claim 54 wherein the dispersion plate is attached to an outer face of the lower surface.

56. A pod as claimed claim 42 comprising more than one dispersion plate.

57. A pod as claimed in claim 1 which is circular with a diameter of between 30 and 110 mm.

58. A pod as claimed in claim 57 wherein the storage volume further contains one or more absorbent elements or particles or foamed plastic elements or particles.

59. A pod as claimed in claim 58 wherein the absorbent elements or particles are spongiform.

60. A pod as claimed in claim 58 wherein the absorbent elements or particles are a hydrogel.

61. A pod as claimed in claim 58 wherein, before exposure to liquid, the one or more absorbent elements or particles or foamed plastic elements or particles are compressed.

62. A pod as claimed in claim 59 wherein, in use, the one or more spongiform elements act as an absorbent means for retaining excess moisture.

63. A pod as claimed in claim 58 containing a single spongiform or hydrogel element.

64. A pod as claimed in claim 58 wherein the one or more absorbent elements or particles interact with water in use such as to absorb water only during a portion of a dispense cycle.

65. A pod as claimed in claim 64 wherein the one or more absorbent elements or particles interact with water at a pre-determined temperature, pH or a start of a specified chemical reaction.

66. A pod as claimed in claim 64 wherein the one or more absorbent elements or particles comprise a soluble coating which, in use, is dissolvable in water to allow absorption of water to take place.

67. A pod as claimed in claim 66 wherein the soluble coating comprises sugar or gelatine.

68. A pod as claimed in claim 58 wherein the one or more absorbent elements or particles comprise one or more of compressed sponge, natural sponges, dried seaweed, poly (HEMA) 2 hydroxyethyl methacrylate, polyacrylic, polyacrylamide, Gelatine, Alginates, Agar and Carrageenan, and other hydrocolloids.

69. A pod as claimed in claim 1 wherein the water-soluble composition is agglomerated.

70. A pod as claimed in claim 69 wherein the agglomerated water-soluble composition is produced by contacting the

water-soluble composition with steam, water, or aqueous solution or dispersion to effect agglomeration, and optionally, either simultaneously or subsequently drying the agglomerated composition.

71. A pod as claimed in claim 70 wherein the water-soluble composition is a milk powder or creamer powder or chocolate powder.

72. A pod as claimed in claim 71 wherein the milk powder or creamer powder is a dairy or non-dairy spray-dried coffee creamer or coffee whitener.

73. A pod as claimed in claim 72 wherein a fat component of the milk powder or creamer powder has a melting point of 10 to 40 degrees Celsius.

74. A pod as claimed in claim 73 wherein the creamer powder comprises one or more of vegetable fat, milk proteins, emulsifiers, stabilisers, foaming agents, milk fat, soy proteins, modified starches, carriers, fillers, sweeteners, flavours, colours, nutrients, preservatives and flow agents.

75. A pod as claimed in claim 1 further comprising one or more channels or grooves in the upper surface, said channels or grooves extending towards the inlet.

76. A pod as claimed in claim 75 wherein the channels have a depth of 0.1 to 5 mm.

77. A pod as claimed in claim 76 wherein the channels or grooves have a depth of about 1 to 2 mm.

78. A pod as claimed in claim 75 wherein the channels and grooves extend radially towards a central inlet.

79. A pod as claimed in claim 1 wherein the upper surface comprises vertical struts, pyramid structures or similar.

80. A pod as claimed in claim 1 further comprising means at or near the outlet for foaming the beverage.

81. A pod as claimed in claim 80 wherein the means for foaming the beverage is an aperture for forming a jet of beverage and subsequently impacting said jet of beverage against an impingement surface so as to produce foaming of the beverage.

82. A pod as claimed in claim 80 wherein the means for foaming the beverage is an eductor or venturi ejector for forming a jet of beverage and including gas into the beverage jet.

83. A pod as claimed in claim 81 wherein the means for foaming the beverage comprises a sintered outlet nozzle, or zeolite bed or membrane.

84. A pod as claimed in claim 81 wherein the means comprises an aperture through which the beverage is directed.

85. A pod as claimed in claim 1 further comprising a gasket seal on or adjacent the upper surface for sealing, in use, against a pod holder of a beverage preparation machine in which the pod is used.

86. A pod as claimed in claim 1 further comprising a peripheral seal on an outer surface of the sidewall for sealing, in use, against a pod holder of a beverage preparation machine in which the pod is used.

87. A pod as claimed in claim 1 further comprising a seal on or adjacent a lower edge of the sidewall for sealing, in use, against a pod holder of a beverage preparation machine in which the pod is used.

88. A pod as claimed in claim 1 wherein the storage volume is a unitary volume.

89. A pod as claimed in claim 1 wherein the storage volume comprises a plurality of compartments.

90. A pod as claimed in claim 89 wherein the plurality of compartments comprises different beverage ingredients.

91. A pod as claimed in claim **89** wherein one or more of the compartments contain one or more absorbent elements or particles or foamed plastic elements or particles.

92. A pod as claimed in claim **1** wherein the one or more apertures forming the inlet to the pod are formed in the side-wall rather than the upper surface.

93. A pod as claimed in claim **92** wherein the apertures are circular, square or slits or other geometric shapes.

94. A pod as claimed in claim **1** wherein the storage volume comprises one or more baffles.

95. A beverage brewing kit comprising a first pod as claimed in claim **1** in combination with a flexible filter pad containing one or more beverage ingredients suitable for brewing.

96. A beverage brewing kit as claimed in claim **95** wherein the flexible filter pad contains roast and ground coffee.

97. A beverage brewing kit as claimed in claim **95** wherein the pod and pad are joined prior to use.

98. A water-soluble composition of a milk powder or creamer powder containing a plurality of dispersed absorbent particles.

99. A method of dispensing a beverage using a pod as claimed in claim **1** comprising the step of passing water downwardly through the pod such that beverage initially exits the pod through a lowermost surface thereof.

100. A method of dispensing a beverage using a pod as claimed in claim **1** comprising the step of passing water upwardly through the pod such that beverage initially exits the pod through an uppermost surface thereof.

101. A method of dispensing a beverage using a pod as claimed in claim **1** comprising the step of orientating the pod in a non-horizontal orientation and passing water in a vertical or non-vertical direction through the pod.

102. A method of dispensing a beverage using a pod as claimed in claim **1** wherein flow of water through the pod may be substantially parallel to a major axis of the pod or substantially cross-ways to a major axis of the pod or in a direction part-way between parallel flow and cross flow.

103. A method of dispensing a beverage using a pod as claimed in claim **1** comprising the step of passing water through the pod at a temperature greater than 70 degrees Celsius.

104. A method of dispensing a beverage using a pod as claimed in claim **1** comprising the step of passing water through the pod as a discontinuous flow.

105. A method of dispensing a beverage as claimed in claim **104** wherein the discontinuous flow of water is a pulsed flow.

* * * * *