



INTERNATIONAL APPLICATION PUBLISHED UNDER THE PATENT COOPERATION TREATY (PCT)

<p>(51) International Patent Classification ⁶ : G02B 5/30, G02F 1/1335</p>	<p>A1</p>	<p>(11) International Publication Number: WO 98/12584 (43) International Publication Date: 26 March 1998 (26.03.98)</p>
<p>(21) International Application Number: PCT/EP97/04827 (22) International Filing Date: 5 September 1997 (05.09.97) (30) Priority Data: 96114855.8 17 September 1996 (17.09.96) EP (34) Countries for which the regional or international application was filed: DE et al. (71) Applicant (for all designated States except US): MERCK PATENT GMBH [DE/DE]; Frankfurter Strasse 250, D-64293 Darmstadt (DE). (72) Inventors; and (75) Inventors/Applicants (for US only): VERRALL, Mark [GB/GB]; 44 Queens Road, Blandford Forum, Dorset DT11 7LA (GB). GOULDING, Mark [GB/GB]; Flat 3, 20 Durrant Road, Lower Parkstone, Poole, Dorset BH14 8TP (GB). HODGES, Quentin [GB/GB]; 7 Gosling Close, Canford Heath, Poole NH17 8QR (GB). GODDEN, Ben [GB/GB]; 95 Twyford Way, Canford Heath, Poole BH17 8SR (GB). (74) Common Representative: MERCK PATENT GMBH; Frankfurter Strasse 250, D-64293 Darmstadt (DE).</p>		<p>(81) Designated States: JP, KR, US, European patent (AT, BE, CH, DE, DK, ES, FI, FR, GB, GR, IE, IT, LU, MC, NL, PT, SE). Published <i>With international search report. Before the expiration of the time limit for amending the claims and to be republished in the event of the receipt of amendments.</i></p>

(54) Title: OPTICAL RETARDATION FILM

(57) Abstract

The invention relates to an optical retardation film comprising two layers of an anisotropic polymer adjacent to each other or adjacent to both sides of a substrate, characterized in that each layer exhibits a tilted structure with an optical symmetry axis having a tilt angle θ relative to the plane of the layer, to a means to produce substantially linear polarized light comprising such an optical retardation film and to a liquid crystal display comprising such an optical retardation film.

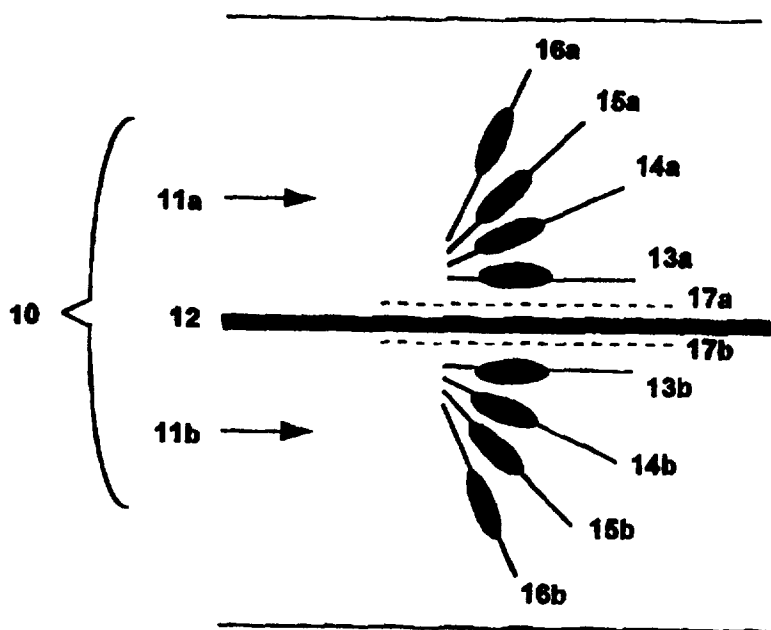

FOR THE PURPOSES OF INFORMATION ONLY

Codes used to identify States party to the PCT on the front pages of pamphlets publishing international applications under the PCT.

AL	Albania	ES	Spain	LS	Lesotho	SI	Slovenia
AM	Armenia	FI	Finland	LT	Lithuania	SK	Slovakia
AT	Austria	FR	France	LU	Luxembourg	SN	Senegal
AU	Australia	GA	Gabon	LV	Latvia	SZ	Swaziland
AZ	Azerbaijan	GB	United Kingdom	MC	Monaco	TD	Chad
BA	Bosnia and Herzegovina	GE	Georgia	MD	Republic of Moldova	TG	Togo
BB	Barbados	GH	Ghana	MG	Madagascar	TJ	Tajikistan
BE	Belgium	GN	Guinea	MK	The former Yugoslav Republic of Macedonia	TM	Turkmenistan
BF	Burkina Faso	GR	Greece			TR	Turkey
BG	Bulgaria	HU	Hungary	ML	Mali	TT	Trinidad and Tobago
BJ	Benin	IE	Ireland	MN	Mongolia	UA	Ukraine
BR	Brazil	IL	Israel	MR	Mauritania	UG	Uganda
BY	Belarus	IS	Iceland	MW	Malawi	US	United States of America
CA	Canada	IT	Italy	MX	Mexico	UZ	Uzbekistan
CF	Central African Republic	JP	Japan	NE	Niger	VN	Viet Nam
CG	Congo	KE	Kenya	NL	Netherlands	YU	Yugoslavia
CH	Switzerland	KG	Kyrgyzstan	NO	Norway	ZW	Zimbabwe
CI	Côte d'Ivoire	KP	Democratic People's Republic of Korea	NZ	New Zealand		
CM	Cameroon			PL	Poland		
CN	China	KR	Republic of Korea	PT	Portugal		
CU	Cuba	KZ	Kazakstan	RO	Romania		
CZ	Czech Republic	LC	Saint Lucia	RU	Russian Federation		
DE	Germany	LI	Liechtenstein	SD	Sudan		
DK	Denmark	LK	Sri Lanka	SE	Sweden		
EE	Estonia	LR	Liberia	SG	Singapore		

Optical Retardation Film

5 The invention relates to an optical retardation film comprising two layers of an anisotropic polymer that are adjacent to each other or adjacent to both sides of a common substrate, characterized in that each layer exhibits a tilted structure with an optical symmetry axis having a tilt angle θ relative to the plane of the layer.

10 The invention further relates to a method of preparing such an optical retardation film, to a means to produce substantially linear polarized light comprising such an optical retardation film and to a liquid crystal display comprising a display cell and such an optical retardation film.

15 Figures 1a to 1c illustrate the structure of optical retardation films according to preferred embodiments of the present invention.

Figure 2a and 2b show a display device according to a preferred embodiment of the present invention.

20 Figure 3a and 3b show the retardation versus viewing angle of an inventive optical retardation film compared to optical retardation films of the state of the art, measured in two directions of observation.

25 Figure 4 shows the normalized retardation versus wavelength for an inventive optical retardation film compared to optical retardation films of the state of the art.

30 Figure 5 shows the retardation versus viewing angle of an inventive optical retardation film, measured in two directions of observation.

35 Figure 6a and 6b show the luminance versus viewing angle for an inventive combination of a broad waveband circular reflective polarizer and an inventive optical retardation film, compared to a combination of a broad waveband circular reflective polarizer and different optical retardation films of the state of the art.

5 The European Patent Application EP 0 606 940-A1 discloses a cholesteric reflective polarizer that produces circular polarized light of a high luminance over a broad range of wavelengths. This polarizer can also be combined with a quarter wave foil or plate (QWF), which transforms the circular polarized light transmitted by the cholesteric polarizer into linear polarized light.

10 However, when a liquid crystal display comprising a cholesteric polarizer like that described in EP 0 606 940 is watched under an increasing viewing angle, its optical properties, like e.g. the luminance and the contrast ratio, are often deteriorating.

15 It has therefore been desired to have available an optical retardation film that, when used together with a broad waveband cholesteric circular reflective polarizer or a combination comprising a circular reflective polarizer and a quarter wave foil, like e.g. described in EP 0 606 940, improves the optical properties of the above mentioned circular reflective polarizer or combination over a wide range of viewing angles.

20 One of the aims of the present invention is to provide an optical retardation film having the properties described above. Another aim of the invention is to provide a means to produce substantially linear polarized light comprising such an optical retardation film and a broadband circular reflective polarizer. Other aims of the present invention are immediately evident to the person skilled in the art from the following detailed description.

30 It has now been found that these aims can be achieved by providing an optical retardation film comprising two layers of an anisotropic polymer that are adjacent to each other or adjacent to both sides of a substrate, characterized in that each layer exhibits a tilted structure with an optical symmetry axis having a tilt angle θ relative to the plane of the layer.

35

5 Furthermore it has been found that an optical retardation film as described above can also be used as a compensation film in conventional LC displays, like for example TN, STN or active matrix driven (AMD) TN displays, in order to compensate the viewing angle dependence of the electrooptical properties, like e.g. the contrast and grey scale, in these displays.

10 A retardation film with a tilted molecular structure is described in the WO 96/19770-A1, whereas the WO 96/19770-A1 discloses a retardation film with a tilted structure wherein the tilt angle varies continuously in a direction normal to the film. However, there is no hint to the combined use of such a retardation film with a broadband circular reflective polarizer in these documents.

15 One of the objects of the present invention is an optical retardation film comprising two layers of an anisotropic polymer that are adjacent to each other or adjacent to both sides of a common substrate, characterized in that each layer exhibits a tilted structure with an optical symmetry axis having a tilt angle θ relative to the plane of the layer.

20 In a preferred embodiment of the present invention the optical retardation film exhibits a tilted structure wherein the tilt angles of the two layers vary from one another.

25 In another preferred embodiment the optical retardation film exhibits a tilted structure wherein the tilt angle in each layer varies continuously, i.e. assumes a splay configuration, wherein the preferred embodiment is characterized in that either the direction of the variation or the amount of the starting values of the variation of the tilt angle are different between the two layers.

30 In the first layer according to this preferred embodiment the tilt angle θ varies, preferably continuously, in a direction normal to the layer from a minimum value θ_{\min} on the side of the layer facing the second layer or, if present, the common intermediate substrate, to a

35

- 4 -

maximum value θ_{\max} on the opposite side of the layer, or the other way round.

5 In the second layer, the tilt angle varies, preferably continuously, in a direction normal to the layer, starting from a minimum value θ_{\min} at the side of the layer facing the first layer or, if present, the common intermediate substrate, and ranging to a maximum value θ_{\max} on the opposite side of the layer, as in the first layer.

10 In another preferred embodiment of the present invention, the tilt angle in the second layer varies in the opposite direction of the first layer, i.e. when the first layer varies from θ_{\min} to θ_{\max} , the second varies from θ_{\max} to θ_{\min} , and vice versa.

15 In a preferred embodiment of the present invention, the minimum tilt angle θ_{\min} in each layer is substantially zero degrees.

20 In another preferred embodiment of the present invention the optical retardation film exhibits structure wherein the projection of the optical symmetry axis of the first layer into the plane of the layer and the projection of the optical symmetry axis of the second layer into the plane of the layer are twisted relative to each other at an angle ρ in the plane of the interface between the layers, said angle ρ being preferably from 0 to 90 degrees.

25 In a preferred embodiment of the present invention the angle ρ is substantially 0 degrees.

30 In another preferred embodiment of the present invention the retardation of the optical retardation film is from 50 to 250 nm.

Another object of the present invention is an optical retardation film as described above that is obtainable by a method comprising the following steps

35 A) coating a mixture comprising

- 5 -

- 5
- a) a polymerizable mesogenic material comprising at least one polymerizable mesogen having at least one polymerizable functional group,
 - b) an initiator, and
 - c) optionally a solvent
- 10
- on a substrate or between a first and a second substrate in form of a layer,
- 15
- B) aligning the polymerizable mesogenic material in the coated layer into a tilted and optionally a splayed structure.
 - C) polymerizing said mixture of a polymerizable mesogenic material by exposure to heat or actinic radiation,
 - 20 D) optionally removing the substrate or, if two substrates are present, one or two of the substrates from the polymerized material, and
 - E) repeating the steps A), B), C) and optionally step D) at least one more time.
- 25

In a preferred embodiment of the present invention the steps A), B) and C) are carried out on both sides of one substrate.

30 In another preferred embodiment of the present invention the mixture of the polymerizable mesogenic material used in the method described above comprises at least one polymerizable mesogen having one polymerizable functional group and at least one polymerizable mesogen having two or more polymerizable functional groups.

35

In another preferred embodiment of the present invention the polymerizable mesogens are compounds of formula I



5

wherein

P is a polymerizable group,

10 Sp is a spacer group having 1 to 20 C atoms,

X is a group selected from -O-, -S-, -CO-, -COO-, -OCO-, -OCOO- or a single bond,

15 n is 0 or 1,

MG is a mesogenic or mesogeneity supporting group, preferably selected according to formula II



wherein

25 A¹, A² and A³ are independently from each other 1,4-phenylene in which, in addition, one or more CH groups may be replaced by N, 1,4-cyclohexylene in which, in addition, one or two non-adjacent CH₂ groups may be replaced by O and/or S, 1,4-cyclohexenylene or naphthalene-2,6-diyl, it being possible for all these groups to be unsubstituted, 30 mono- or polysubstituted with halogen, cyano or nitro groups or alkyl, alkoxy or alkanoyl groups having 1 to 7 C atoms wherein one or more H atoms may be substituted by F or Cl,

35 Z¹ and Z² are each independently -COO-, -OCO-, -CH₂CH₂-, -OCH₂-, -CH₂O-, -CH=CH-, -C≡C-, -CH=CH-COO-,

- 7 -

-OCO-CH=CH- or a single bond,

m is 0, 1 or 2,

5 and

R is an alkyl radical with up to 25 C atoms which may be unsubstituted, mono- or polysubstituted by halogen or CN, it being also possible for one or more non-adjacent CH₂ groups to be replaced, in each case independently from one another, by -O-, -S-, -NH-, -N(CH₃)-, -CO-, -COO-, -OCO-, -OCO-O-, -S-CO-, -CO-S- or -C≡C- in such a manner that oxygen atoms are not linked directly to one another, or alternatively R is halogen, cyano or has independently one of the meanings given for P-(Sp-X)_n.

10

15

Another object of the present invention is a means to produce substantially linear polarized light, comprising a broadband circular reflective polarizer and an optical retardation film as described in the foregoing and the following.

20

Another object of the present invention is a liquid crystal display comprising a display cell and an optical retardation film as described in the foregoing and the following.

25

Yet another object of the present invention is a liquid crystal display comprising a display cell and a means to produce substantially linear polarized light as described in the foregoing and the following.

As mentioned above, a preferred embodiment of the present invention is characterized in that the optical retardation film exhibits a tilted and splayed structure, wherein the tilt angle θ in each layer varies continuously in a direction normal to the layer, starting from a minimum value θ_{\min} at the side of the layer facing the other layer or, if present, facing the common intermediate substrate, and ranging to a

30

35

- 8 -

maximum value θ_{\max} on the opposite side of the layer, or the other way round.

5 Figure 1a depicts the structure of an optical retardation film **10** according to this preferred embodiment in side view, as an example that should illustrate, but not limit, the scope of the present invention. The optical retardation film **10** is comprising a first layer **11a** and a second layer **11b** of a polymerized mesogenic material on both sides of a common intermediate substrate **12**.

10 Each of the layers **11a** and **11b** shown in figure 1a is exhibiting a tilted and splayed structure, wherein the mesogens of the polymerized material are oriented such that the major optical axes in different parts of the layer, of which locations at the surface are represented by lines **13a/b** and **16a/b**, and arbitrary intermediate locations are represented by lines **14a/b** and **15a/b**, each have a tilt angle θ relative to the plane of the layer, which is increasing in a direction normal to the layer, beginning with a minimum value θ_{\min} on the side of each layer facing the common substrate **12**.

20 In the inventive optical retardation film that is shown in figure 1a, the mesogens on the side of each layer facing the substrate have a planar orientation, i.e. the major optical axes of these mesogens, represented by lines **13a** and **13b**, have a minimum tilt angle θ_{\min} that is substantially 0 degrees. However, other values of θ_{\min} are also possible.

30 The orientation of the optical axes in the two layers of the inventive optical retardation film depicted in figure 1a can further be described by an angle ρ in the plane of the common substrate **12** between the lines **17a** and **17b**, wherein **17a** is representing the projection of the major optical axis in different parts of the first layer, indicated by lines **13a**, **14a**, **15a** and **16a**, into the plane of the first layer, and **17b** is representing the projection of the major optical axis in different parts of the second layer, indicated by lines **13b**, **14b**, **15b** and **16b**, into the plane of the second layer.

35

Thus, this angle ρ gives the amount by which the two layers are twisted against each other.

5 In the preferred embodiment shown in figure 1a, the angle ρ between lines **17a** and **17b** is substantially zero degrees. However, other values of ρ are also possible.

10 Figure 1b illustrates the molecular structure of an optical retardation film **10** according to another preferred embodiment of the present invention. The numbered elements in figure 1b have the same meaning as given for figure 1a. The film **10** in figure 1b consists of two layers **11a** and **11b** that are coated on two substrates **12a** and **12b**, wherein the tilt angle θ in each layer **11a** and **11b** varies
15 continuously in a direction normal to the layer, beginning on the side of each layer facing the common substrate **12a** between the layers with a minimum value θ_{\min} in the first layer **11a** and a maximum value θ_{\max} in the second layer **11b**.

20 In an inventive optical retardation film according to the preferred embodiment which is exemplarily described in figures 1a and 1b, the sense of variation of the tilt angle θ in each layer may be clockwise or counterclockwise when going from low values to high values of θ , and when looking at the layer in side view. The sense of variation of
25 the tilt angle θ can be the same or different in both layers. Preferably the sense of variation is opposite in the two layers, as for example depicted in figures 1a and 1b.

30 In the optical retardation films according to the preferred embodiment which is described above, and which is exemplarily depicted in figures 1a and 1b, the minimum tilt angle θ_{\min} is preferably from 0 to 20 degrees, in particular from 0 to 10 degrees, most preferably from 0 to 5 degrees.

35 The maximum tilt angle θ_{\max} in an optical retardation film according to this preferred embodiment is preferably from 20 to 90 degrees, in

- 10 -

particular from 30 to 90 degrees, most preferably from 35 to 90 degrees.

5 Preferably the tilt angles of the two layers a and b at surfaces facing each other either directly or via a common substrate are the same, that is either $\theta_{\min, a} = \theta_{\min, b}$ or $\theta_{\max, a} = \theta_{\max, b}$. Very preferably both the minimum and the maximum tilt angle of the two layers are the same, that is $\theta_{\min, a} = \theta_{\min, b}$ and $\theta_{\max, a} = \theta_{\max, b}$.

10 In another preferred embodiment of the present invention, the optical retardation film is characterized in that the tilt angle θ is substantially constant in each layer. The molecular structure of an optical retardation film according to this preferred embodiment is exemplarily described in figure 1c, wherein the numbered elements
15 have the same meanings as given for figure 1a.

Thus, an optical retardation film according to this preferred embodiment can be described by one tilt angle θ for each layer, which is ranging from 0 to 90 degrees, with the tilt angle in the first
20 layer and the tilt angle in the second layer being independent of one another but preferably having substantially the same value.

The tilt angle θ according to this preferred embodiment is preferably from 5 to 80 degrees, in particular from 15 to 70 degrees, very
25 preferably from 25 to 60 degrees.

In the preferred embodiments as shown in figures 1a to 1c, the angle ρ between lines 17a and 17b is substantially zero degrees. However, other values for the angle ρ that are different from zero degrees are
30 also possible. In principle, the angle ρ can vary from 0 to 90 degrees. Preferably ρ is substantially 0 degrees or 90 degrees, most preferably 0 degrees.

In case the tilt angles θ_{\min} and θ_{\max} of the two layers are identical, that is $\theta_{\min, a} = \theta_{\min, b}$ and $\theta_{\max, a} = \theta_{\max, b}$, and the angle ρ is substantially
35 zero degrees, the two layers have a structure which in the ideal case

the ideal case shows mirror symmetry, with the interface or, if present, the substrate between the layers being a mirror plane, like depicted in figures 1a and 1c.

5 Preferably the inventive optical retardation film exhibits a symmetrical structure wherein the interface or, if present, the substrate between the two layers is a mirror plane.

10 Figure 1b represents an embodiment which is optically equivalent to the embodiment shown in figure 1a, but with the two layers being coated on two separate substrates.

15 Analogously the corresponding optically equivalent to the embodiment shown in figure 1c can be obtained by combining two layers with constant tilt angle formed on two separate substrates.

20 The inventive optical retardation film does not necessarily have to comprise a substrate between the two layers of anisotropic polymer. In a preferred embodiment of the present invention, the two layers are directly adjacent to each other. Such an optical retardation film can be described in analogy to figures 1a to 1c, wherein 12 and 12a respectively are indicating the interface between the two layers.

25 The retardation of the inventive optical retardation film is preferably ranging from 50 to 250 nm, very preferably from 60 to 200 nm, most preferably from 70 to 170 nm.

30 Another object of the present invention is a means to produce substantially linear polarized light, comprising an optical retardation film as described in the foregoing and the following in combination with a broadband circular reflective polarizer. When using this combination, light that is substantially linearly polarized can be produced.

35 The bandwidth of the wavelength band reflected by said broadband circular reflective polarizer is at least 100 nm, preferably at least 150

- 12 -

nm, most preferably at least 200 nm, ideally 250 nm or larger. Preferably the bandwidth of the circular reflective polarizer is covering the spectrum of visible light.

5 In another preferred embodiment of the present invention, the retardation of the optical retardation film is substantially 0.25 times a wavelength reflected by the broadband circular reflective polarizer, so that the optical retardation film serves as a quarter wave retardation film.

10

For a liquid crystal display comprising a broad band circular reflective polarizer and an optical retardation film of the state of the art, like e.g. a quarter wave film (QWF) made of stretched PVA, the luminance at normal incidence (viewing angle 0°) and at low values of the viewing angle is increased compared to a liquid crystal display comprising the circular reflective polarizer alone without an optical retardation film.

15

However, as the display comprising the a broad band circular reflective polarizer and a state of the art QWF as mentioned above is viewed under an increasing angle, the increasing phase retardation by the QWF itself causes a reduction to the luminance, coinciding with the value measured for the display comprising the circular reflective polarizer as a single component at a certain angle. This angle is referred to as the 'cross-over angle' α_c .

20

When using an inventive optical retardation film instead of a state of the art QWF in the liquid crystal display, the cross-over angle α_c can be increased significantly. In other words, the brightness enhancement, i.e. the increase of luminance at low viewing angles, that was achieved by using the circular reflective polarizer can be extended also to large viewing angles.

25

The cross over angle α_c of a display comprising a combination of optical elements comprising an optical retardation film and a broadband circular reflective polarizer according to the present invention is preferably 25° or larger, particularly preferably 30° or

30

35

larger, very particularly preferably 35 ° or larger in at least one direction of observation, e.g. in horizontal or vertical direction.

5 The means to produce substantially linear polarized light can comprise other optical elements in addition to the inventive optical retardation film and the circular reflective polarizer. Preferably said means additionally comprises at least one of the following elements:

- 10 I) a compensation film comprising a layer of an anisotropic polymer material with a homeotropic or tilted homeotropic orientation, said compensation film being positioned adjacent to either side of the inventive optical retardation film,
- 15 II) a linear polarizer, arranged in such a manner that the inventive optical retardation film and, if present, the compensation film I) are positioned between the broadband circular reflective polarizer and the linear polarizer,
- 20 III) a radiation source, and
- IV) a diffusor adjacent to the radiation source,

25 wherein the components I to IV are arranged in such a manner that the broadband circular reflective polarizer of the combination of optical elements is facing the radiation source III or, if present, the diffusor IV.

30 As a linear polarizer II a commercially available polarizer can be used. In a preferred embodiment of the present invention the linear polarizer is a low contrast polarizer. In another preferred embodiment of the present invention the linear polarizer II is a dichroic polarizer.

35 As a radiation source III preferably a standard backlight for liquid crystal displays, like e.g. a side-lit or a meander type backlight, is used. These backlights typically comprise a lamp, a reflector, a light guide and optionally a diffuser.

The radiation source III can also consist of a reflector that reflects radiation generated outside the means to produce substantially linear polarized light. The display device according to the present invention can then be used as a reflective display.

5

The means to produce substantially linear polarized light according to the present invention can further comprise

10

V) one or more adhesive layers provided to at least one of the optical components comprising the circular reflective polarizer, the inventive optical retardation film or one of the components I to IV described above,

15

VI) one or more protective layers provided to at least one of the optical components comprising the circular reflective polarizer, the inventive optical retardation film or one of the components I to V described above.

20

Another object of the present invention is a liquid crystal display comprising a display cell and a means to produce substantially linear polarized light as described in the foregoing and the following.

25

The function of the inventive means to produce substantially linear polarized light is further explained by figure 2, which shows a display device according to a preferred embodiment of the present invention, as an example that should not limit the scope of the invention. The main direction of light following the optical path is from the left side to the right side. The display device 20 consists of a side-lit backlight unit 21 with a lamp 22a and a combined light guide and reflector 22b, a diffusor 23 and a polarizer combination consisting of a circular reflective polarizer 24 comprising a layer of a liquid crystalline material with a helically twisted molecular orientation, the inventive optical retardation film 25, a compensation film 26 and a linear polarizer 27. The figure further depicts a liquid crystal cell 28 and a second linear polarizer 29 behind the display cell.

35

Light emitted from the backlight **21** is interacting with the molecular helix structure of the circular reflective polarizer **24** with the result that 50 % of the intensity of the light incident on the circular reflective polarizer is reflected as circular polarized light of the same twist sense as that of the molecular helix structure of the circular reflective polarizer, which may be either right-handed or left-handed, whereas the other 50 % of the incident light are reflected as circular polarized light of the opposite twist sense. The reflected light is depolarized in the backlight and redirected by the reflector **22b** onto the circular reflective polarizer **24**. In this manner, theoretically 100 % of the light of a broad range of wavelengths emitted from the backlight **21** are converted into circularly polarized light.

The main part of the transmitted component is converted by the inventive optical retardation film **25** into linear polarized light, which is then compensated by the compensation film **26** and being transmitted by the linear polarizer **27**, whereas light which is not completely transferred into linear polarized light by the optical retardation film **25**, such as elliptically polarized light, is not transmitted by the linear polarizer **27**. The linear polarized light then passes through the display **28** and the second linear polarizer **29** to reach the viewer **30**.

Figure 2b depicts a display device according to another preferred embodiment of the invention having essentially the same assembly as that shown in Figure 1a, with the difference that in the assembly shown in figure 2b the inventive optical retardation film **25** is placed behind the compensation film **26** when looking from the direction of incident light.

As mentioned above, it is also possible to use the inventive optical retardation film as a compensation film for conventional displays, like TN, STN, AMD-TN or other types of displays.

- 16 -

Thus, another object of the present invention is a liquid crystal display comprising a display cell and an optical retardation film as described in the foregoing and the following.

- 5 Preferably the optical retardation film is obtainable by a process comprising the following steps
- A) coating a mixture comprising
- 10 a) a polymerizable mesogenic material comprising at least one polymerizable mesogen having at least one polymerizable functional group,
- b) an initiator, and
- 15 c) optionally a solvent
- on a substrate or between a first and a second substrate in form of a layer,
- 20 B) aligning the polymerizable mesogenic material in the coated layer into a tilted and optionally a splayed structure.
- C) polymerizing said mixture of a polymerizable mesogenic material by exposure to heat or actinic radiation,
- 25 D) optionally removing the substrate or, if two substrates are present, one or two of the substrates from the polymerized material, and
- 30 E) repeating the steps A), B), C) and optionally step D) at least one more time.

35 In a preferred embodiment of the present invention the steps A), B) and C) are carried out on both sides of a common substrate. In this way an optical retardation film as described in figure 1 is obtained.

5 As a substrate for example a glass or quartz sheet as well as a plastic film or sheet can be used. It is also possible to put a second substrate on top of the coated mixture prior to and/or during and/or after polymerization. The substrates can be removed after polymerization or not. When using two substrates in case of curing by actinic radiation, at least one substrate has to be transmissive for the actinic radiation used for the polymerization.

10 Isotropic or birefringent substrates can be used. In case the substrate is not removed from the polymerized film after polymerization, preferably isotropic substrates are used.

15 Preferably at least one substrate is a plastic substrate such as for example a film of polyester such as polyethyleneterephthalate (PET), of polyvinylalcohol (PVA), polycarbonate (PC) or triacetylcellulose (TAC), especially preferably a PET film or a TAC film. As a birefringent substrate for example an uniaxially stretched plastic film can be used. For example PET films are commercially available from
20 ICI Corp. under the trade name Melinex.

The mixture comprising the polymerizable mesogenic material can additionally comprise a solvent. If the mixture contains a solvent, this is preferably evaporated after coating the mixture onto the substrate
25 before polymerization. In most cases it is suitable to heat the mixture in order to facilitate the evaporation of the solvent.

In principal every solvent can be used that is known to the skilled in the art for this purpose. Preferably a solvent is used wherein the
30 polymerizable mesogenic material dissolves easily. Typically an organic solvent, like e.g. toluene, is used.

In another preferred embodiment of the present invention as described above, each polymerized layer of the mesogenic material on the side facing the other layer or the substrate exhibits
35 substantially planar alignment, i.e. the minimum tilt angle θ_{\min} is

substantially zero degrees. Planar alignment can be achieved for example by shearing the material, e.g. by means of a doctor blade. It is also possible to apply an alignment layer, for example a layer of rubbed polyimide or sputtered SiO_x , on top of at least one of the substrates.

An especially preferred embodiment of the present invention is characterized in that planar alignment of the polymerizable mesogenic material is achieved by directly rubbing the substrate, i.e. without applying an additional alignment layer. This is a considerable advantage as it allows a significant reduction of the production costs of the optical retardation film. In this way a low tilt angle can easily be achieved.

Preferably a plastic film, in particular a polyester film, e.g. Melinex, or a TAC film are used as a substrate in this preferred embodiment.

For example rubbing can be achieved by means of a rubbing cloth or with a flat bar coated with a rubbing cloth.

In another preferred embodiment of the present invention rubbing is achieved by means of a at least one rubbing roller, like e.g. a fast spinning roller that is brushing over the substrate, or by putting the substrate between at least two rollers, wherein in each case at least one of the rollers is optionally covered with a rubbing cloth.

In another preferred embodiment of the present invention rubbing is achieved by wrapping the substrate at least partially at a defined angle around a roller that is preferably coated with a rubbing cloth.

As rubbing cloth all materials can be used that are known to the skilled in the art for this purpose. For example velvet of a commercially available standard type can be used as a rubbing cloth.

Preferably rubbing is carried out only in one direction. Very preferably the rubbing direction on both sides of the substrate is the same.

5 A preferred embodiment of the present invention is characterized in that the two layers of the mesogenic material are adjacent to both sides of a common substrate, like e.g. depicted in figure 1a.

10 Such an optical retardation film, can be obtained for example by coating, aligning and polymerizing a mesogenic material on a substrate that has been rubbed unidirectionally on one side, and subsequently repeating the same process on the other side of the same substrate, wherein the substrate in the second process is rubbed in the same direction as in the first process.

15 Such an optical retardation film is advantageous compared to its optical equivalent, like for example shown in figure 1b, in that it is thinner and requires a lower amount of substrate.

20 An optical retardation film with a angle ρ different from 0 degrees as described above can be obtained if the rubbing directions on the two surfaces of the substrate are different from each other.

25 When using an anisotropic substrate, rubbing is preferably carried out unidirectionally in a direction substantially parallel to the major symmetry axis of the substrate.

30 The ability of the substrate to induce alignment in an inventive polymerizable mesogenic composition, which is coated on this substrate after rubbing the substrate, will depend on the process parameters of the rubbing process, like the rubbing length, the rubbing pressure and rubbing speed and, in case a rubbing roller is used, on the rotational velocity of the roller, the rubbing roller circumference and the tension on the substrate.

35

Thus, the rubbing length in the rubbing process according to the preferred embodiments described above is also depending on the other previously described process parameters of the rubbing process. Preferably the rubbing length is from 0.2 to 5 metres, in particular from 0.5 to 3 metres.

The orientation of the mesogenic material depends, inter alia, on the film thickness, the type of substrate, the alignment state of the substrate surface, and the composition of the polymerizable mesogenic material. Thus, by changing these parameters, it is possible to control the structure of the optical retardation film, and in particular the structure parameters like e.g. the tilt angle and its degree of variation.

When changing the composition of the polymerizable mesogenic mixture, for example by varying the ratio of di reactive to mono reactive compounds and/or polar to unpolar compounds, the alignment profile in the direction perpendicular to the film plane can be altered.

In a preferred embodiment of the present invention the optical retardation film is obtained by a process as described above, wherein the substrate is removed from the polymerized mesogenic material after the first polymerization step. The second layer of polymerizable mesogenic material is then coated directly on the polymerized first layer, which acts as a substrate, and is then aligned and polymerized. In this way an optical retardation film is obtained that comprises two layers of polymerized mesogenic material that are directly adjacent to each other.

When preparing an optical retardation film according to this preferred embodiment, in some cases it is even not necessary to apply special alignment means or methods, since the first polymerized layer can act as aligning layer and can induce alignment in the second layer.

Polymerization of the inventive polymerizable mesogenic mixture takes place by exposing it to heat or to actinic radiation. Actinic

radiation means irradiation with light, X-rays, gamma rays or irradiation with high energy particles, such as ions or electrons. In particular preferably UV light is used. The irradiation wavelength is preferably from 220 nm to 420 nm.

5

As a source for actinic radiation for example a single UV lamp or a set of UV lamps can be used. When using a high lamp power the curing time can be reduced.

10

The curing time is depending, inter alia, on the reactivity of the polymerizable mesogenic material, the thickness of the coated layer, the type of polymerization initiator and the power of the UV lamp. For mass production short curing times are preferred. The curing time according to the invention is preferably not longer than 30 minutes, especially preferably not longer than 15 minutes and very particularly preferably shorter than 8 minutes.

15

The polymerization is carried out in the presence of an initiator absorbing the wavelength of the actinic radiation. For example, when polymerizing by means of UV light, a photoinitiator can be used that decomposes under UV irradiation to produce free radicals that start the polymerization reaction. As a photoinitiator for radicalic polymerization a commercially available photoinitiator like e.g. Irgacure 651 (by Ciba Geigy AG, Basel, Switzerland) can be used.

20

25

It is also possible to use a cationic photoinitiator, when curing polymerizable mesogens with for example vinyl and epoxide polymerizable groups, that photocures with cations instead of free radicals. The polymerization may also be started by an initiator that initiates the polymerization when heated above a certain temperature.

30

35

In addition to light- or temperature-sensitive initiators the polymerizable mixture may also comprise one or more other suitable components such as, for example, catalysts, stabilizers, co-reacting monomers or surface-active compounds.

- 22 -

5 In a preferred embodiment of the invention, the polymerizable mixture comprises a stabilizer that is used to prevent undesired spontaneous polymerization for example during storage of the mixture. As stabilizers in principal all compounds can be used that are known to the skilled in the art for this purpose. These compounds are commercially available in a broad variety. Typical examples for stabilizers are 4-ethoxyphenol or butylated hydroxytoluene (BHT).

10 The polymerizable mixture according to this preferred embodiment preferably comprises a stabilizer as described above at an amount of 1 to 1000 ppm, especially preferably 10 to 500 ppm.

15 Other additives, like e.g. chain transfer agents, can also be added to the polymerizable mixture in order to modify the physical properties of the inventive polymer film. For example when adding a chain transfer agent to the polymerizable mixture, the length of the free polymer chains and/or the length of the polymer chains between two crosslinks in the inventive polymer film can be controlled. When the
20 amount of the chain transfer agent is increased, polymer films with decreasing polymer chain length are obtained.

25 In a preferred embodiment of the present invention the polymerizable mixture comprises 0.01 to 10 %, in particular 0.1 to 5 %, very preferably 0.5 to 3 % of a chain transfer agent. The polymer films according to this preferred embodiment show especially good adhesion to a substrate, in particular to a plastic film, like e.g. a TAC film.

30 As a chain transfer agent for example monofunctional thiol compounds like e.g. dodecane thiol or multifunctional thiol compounds like e.g. trimethylpropane tri(3-mercaptopropionate) can be used.

35 In some cases it is of advantage to apply a second substrate to aid alignment and exclude oxygen that may inhibit the polymerization. Alternatively the curing can be carried out under an atmosphere of inert gas. However, curing in air is also possible using suitable

5 photoinitiators and high UV lamp power. When using a cationic photoinitiator oxygen exclusion most often is not needed, but water should be excluded. In a preferred embodiment of the invention the polymerization of the polymerizable mesogenic material is carried out under an atmosphere of inert gas, preferably under a nitrogen atmosphere.

10 To obtain polymer films with good alignment the polymerization has to be carried out in the liquid crystal phase of the polymerizable mesogenic mixture. Preferably polymerizable mesogenic mixtures are used that have a low melting point, preferably a melting point of 100 °C or lower, in particular 60 °C or lower, so that curing can be carried out in the liquid crystalline phase of the mixture at low temperatures. This is simplifying the polymerization process as less heating of the mixture is required and there is less strain of the mesogenic materials, the substrates and the production equipment during polymerization, which is of importance especially for mass production. Curing temperatures below 100 °C are preferred. Especially preferred are curing temperatures below 60 °C.

20 The thickness of the inventive optical retardation film obtained by the method as described above is preferably from 0.1 to 10 μm , in particular from 0.2 to 5 μm , most preferably from 0.4 to 2 μm . For some applications, a film thickness between 2 and 15 μm is also suitable.

30 In a preferred embodiment of the present invention, the broadband circular reflective polarizer and/or the compensation film of the inventive means to produce linear polarized light are comprising a layer of an anisotropic polymer material that is obtained by polymerizing an oriented layer of polymerizable mesogens.

35 Particularly preferably these polymerizable mesogens have a structure which is similar to that of the polymerizable mesogenic compounds of formula I as described above and below.

Thus, when using an inventive optical retardation film together with a broadband circular reflective polarizer and/or a compensation film according to this preferred embodiment, it is possible to adapt the optical properties of the optical retardation film to those of the circular reflective polarizer and/or the compensation film by using materials comprising compounds with similar structure. In this way a combination of an optical retardation film and a circular reflective polarizer and/or a compensation film with superior optical performance can be obtained.

In a preferred embodiment the polymerizable mixture comprises polymerizable mesogenic compounds having two or more polymerizable functional groups (referred to as di-/multireactive or di-/multifunctional compounds). Upon polymerization of such a mixture a three-dimensional polymer network is formed. An optical retardation film made of such a network is self-supporting and shows a high mechanical and thermal stability and a low temperature dependence of its physical and optical properties.

In another preferred embodiment the polymerizable mixture comprises 0 to 20% of a non mesogenic compound with two or more polymerizable functional groups to increase crosslinking of the polymer. Typical examples for difunctional non mesogenic monomers are alkyldiacrylates or alkyldimethacrylates with alkyl groups of 1 to 20 C atoms. Typical examples for non mesogenic monomers with more than two polymerizable groups are trimethylpropanetrimethacrylate or pentaerythritoltetraacrylate.

By varying the concentration of the multifunctional mesogenic or non mesogenic compounds the crosslink density of the polymer film and thereby its physical and chemical properties such as the glass transition temperature, which is also important for the temperature dependence of the optical properties of the optical retardation film, the thermal and mechanical stability or the solvent resistance can be tuned easily.

- 25 -

5 The terms polymerizable or reactive mesogen, polymerizable or reactive mesogenic compound, polymerizable or reactive liquid crystal (compound) and polymerizable or reactive liquid crystalline compound as used in the foregoing and the following comprise
 10 compounds with a rodlike, boardlike or disklike mesogenic group and at least one polymerizable functional group. These mesogenic compounds do not necessarily have to exhibit mesophase behaviour by themselves. It is also possible that they show mesophase
 15 behaviour in mixtures with other compounds or after polymerization of the pure mesogenic compounds or of the mixtures comprising the mesogenic compounds.

In a particularly preferred embodiment of the present invention, the polymerizable mesogens comprised by the mixture of the
 20 polymerizable mesogenic material are compounds of formula I



wherein

20

P is a polymerizable group,

Sp is a spacer group having 1 to 20 C atoms,

25

X is a group selected from -O-, -S-, -CO-, -COO-, -OCO-, -OCOO- or a single bond,

n is 0 or 1,

30

MG is a mesogenic or mesogeneity supporting group, preferably selected according to formula II

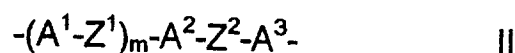

35

wherein

- 26 -

5 A¹, A² and A³ are independently from each other 1,4-phenylene
in which, in addition, one or more CH groups may be
replaced by N, 1,4-cyclohexylene in which, in addition, one
or two non-adjacent CH₂ groups may be replaced by O
and/or S, 1,4-cyclohexenylene or naphthalene-2,6-diyl, it
being possible for all these groups to be unsubstituted,
mono- or polysubstituted with halogen, cyano or nitro
groups or alkyl, alkoxy or alkanoyl groups having 1 to 7 C
atoms wherein one or more H atoms may be substituted by
10 F or Cl,

Z¹ and Z² are each independently -COO-, -OCO-, -CH₂CH₂-,
-OCH₂-, -CH₂O-, -CH=CH-, -C≡C-, -CH=CH-COO-,
-OCO-CH=CH- or a single bond and

15 m is 0, 1 or 2,

and

20 R is an alkyl radical with up to 25 C atoms which may be
unsubstituted, mono- or polysubstituted by halogen or CN, it
being also possible for one or more non-adjacent CH₂ groups to
be replaced, in each case independently from one another, by
-O-, -S-, -NH-, -N(CH₃)-, -CO-, -COO- -OCO-, -OCO-O-, -S-CO-,
25 -CO-S- or -C≡C- in such a manner that oxygen atoms are not
linked directly to one another, or alternatively R is halogen, cyano
or has independently one of the meanings given for P-(Sp-X)_n.

30 Particularly preferred are polymerizable mixtures comprising at least
two polymerizable mesogenic compounds at least one of which is a
compound of formula I.

In another preferred embodiment of the invention the polymerizable
mesogenic compounds are selected according to formula I, wherein
35 R has one of the meanings of P-(Sp-X)_n as given above.

Bicyclic and tricyclic mesogenic compounds are preferred.

Of the compounds of formula I especially preferred are those in which R is F, Cl, cyano, or optionally halogenated alkyl or alkoxy, or has the meaning given for P-(Sp-X)_n-, and MG is of formula II wherein Z¹ and Z² are -COO-, -OCO-, -CH₂-CH₂-, -CH=CH-COO-, -OCO-CH=CH- or a single bond.

A smaller group of preferred mesogenic groups of formula II is listed below. For reasons of simplicity, Phe in these groups is 1,4-phenylene, Phe L is a 1,4-phenylene group which is substituted by at least one group L, with L being F, Cl, CN or an optionally fluorinated alkyl, alkoxy or alkanoyl group with 1 to 4 C atoms, and Cyc is 1,4-cyclohexylene.

15	-Phe-Z ² -Phe-	II-1
	-Phe-Z ² -Cyc-	II-2
	-PheL-Z ² -Phe-	II-3
	-PheL-Z ² -Cyc-	II-4
20	-Phe-Z ² -PheL-	II-5
	-Phe-Z ¹ -Phe-Phe-	II-6
	-Phe-Z ¹ -Phe-Cyc-	II-7
	-Phe-Z ¹ -Phe-Z ² -Phe-	II-8
	-Phe-Z ¹ -Phe-Z ² -Cyc-	II-9
25	-Phe-Z ¹ -Cyc-Z ² -Phe-	II-10
	-Phe-Z ¹ -Cyc-Z ² -Cyc-	II-11
	-Phe-Z ¹ -PheL-Z ² -Phe-	II-12
	-Phe-Z ¹ -Phe-Z ² -PheL-	II-13
	-PheL-Z ¹ -Phe-Z ² -PheL-	II-14
30	-PheL-Z ¹ -PheL-Z ² -Phe-	II-15
	-PheL-Z ¹ -PheL-Z ² -PheL-	II-16

In these preferred groups Z¹ and Z² have the meaning given in formula I described above. Preferably Z¹ and Z² are -COO-, -OCO-, -CH₂CH₂-, -CH=CH-COO- or a single bond.

- 28 -

L is preferably F, Cl, CN, NO₂, CH₃, C₂H₅, OCH₃, OC₂H₅, COCH₃, COC₂H₅, CF₃, OCF₃, OCHF₂, OC₂F₅, in particular F, Cl, CN, CH₃, C₂H₅, OCH₃, COCH₃ and OCF₃, most preferably F, CH₃, OCH₃ and COCH₃.

5

Particularly preferred are compounds wherein MG is selected from the following formulae

10

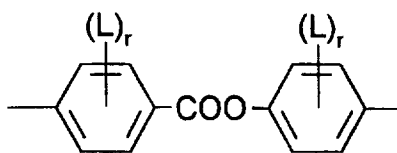

15

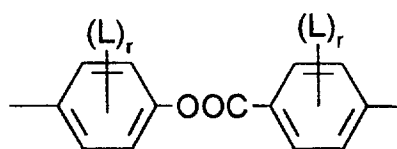

20

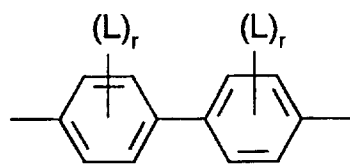

25

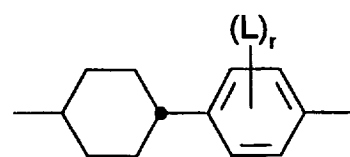

30

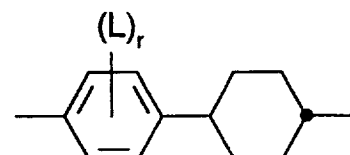

35

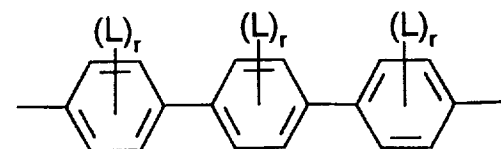

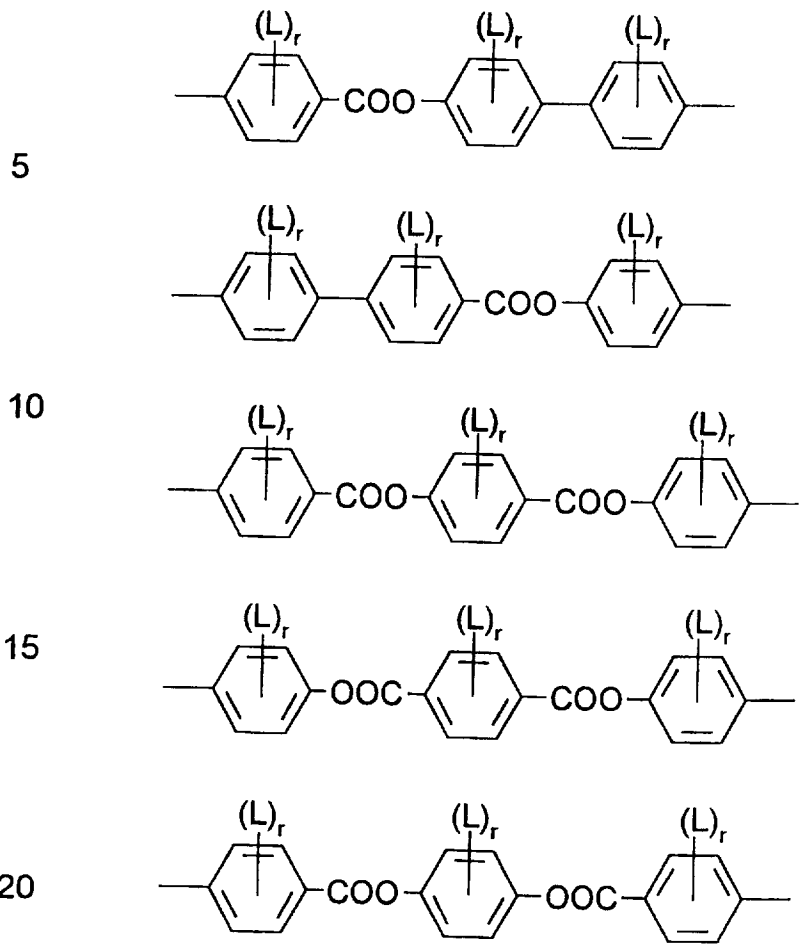

wherein L has the meaning given above and r is 0, 1 or 2.

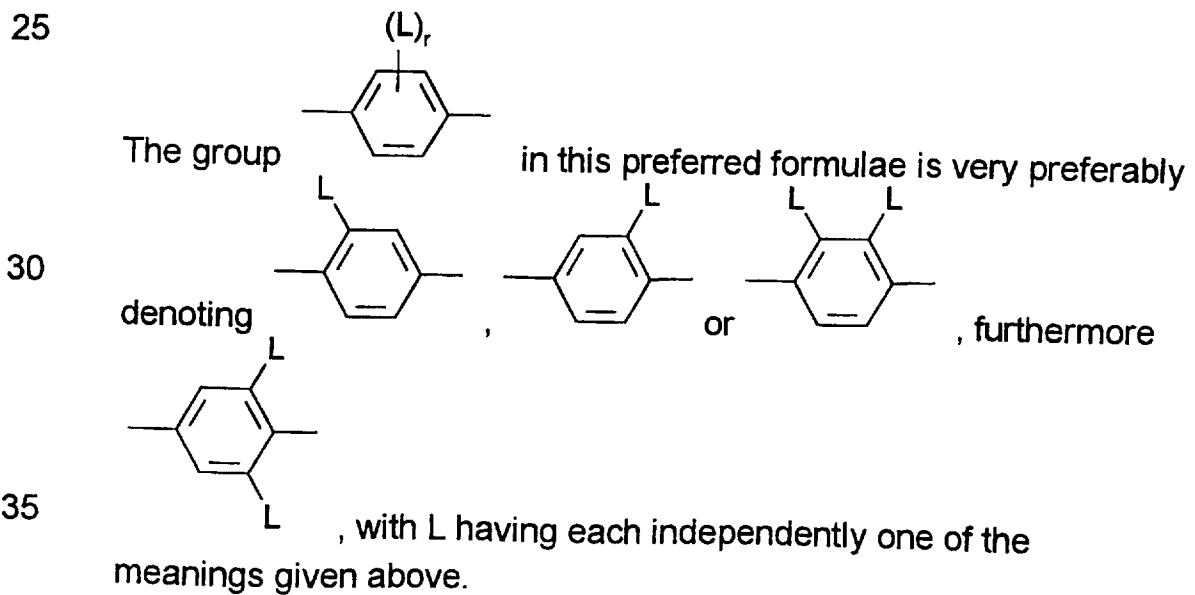

- 30 -

R in these preferred compounds is particularly preferably CN, F, Cl, OCF₃, or an alkyl or alkoxy group with 1 to 12 C atoms or has one of the meanings given for P-(Sp-X)_n.

5

If R in formula I is an alkyl or alkoxy radical, i.e. where the terminal CH₂ group is replaced by -O-, this may be straight-chain or branched. It is preferably straight-chain, has 2, 3, 4, 5, 6, 7 or 8 carbon atoms and accordingly is preferably ethyl, propyl, butyl, pentyl, hexyl, heptyl, octyl, ethoxy, propoxy, butoxy, pentoxy, hexoxy, heptoxy, or octoxy, furthermore methyl, nonyl, decyl, undecyl, dodecyl, tridecyl, tetradecyl, pentadecyl, methoxy, nonoxy, decoxy, undecoxy, dodecoxy, tridecoxy or tetradecoxy, for example.

10

15

Oxaalkyl, i.e. where one CH₂ group is replaced by -O-, is preferably straight-chain 2-oxapropyl (=methoxymethyl), 2- (=ethoxymethyl) or 3-oxabutyl (=2-methoxyethyl), 2-, 3-, or 4-oxapentyl, 2-, 3-, 4-, or 5-oxahexyl, 2-, 3-, 4-, 5-, or 6-oxaheptyl, 2-, 3-, 4-, 5-, 6- or 7-oxaoctyl, 2-, 3-, 4-, 5-, 6-, 7- or 8-oxanonyl or 2-, 3-, 4-, 5-, 6-, 7-, 8- or 9-oxadecyl, for example.

20

In addition, mesogenic compounds of the formula I containing a branched group R can be of importance as comonomers, for example, as they reduce the tendency towards crystallization.

25

Branched groups of this type generally do not contain more than one chain branch. Preferred branched groups are isopropyl, isobutyl (=methylpropyl), isopentyl (=3-methylbutyl), isopropoxy, 2-methylpropoxy and 3-methylbutoxy.

30

P in formula I is preferably selected from CH₂=CW-COO-,

WCH=CH-O-, $\text{WHC} \begin{array}{c} \diagup \text{O} \diagdown \\ \text{---} \text{CH} \text{---} \end{array}$ or CH₂=CH-Phenyl-(O)_k- with W being H, CH₃ or Cl and k being 0 or 1,

35

P is particularly preferably a vinyl group, an acrylate group, a methacrylate group, a propenyl ether group or an epoxy group, very particularly preferably an acrylate or methacrylate group.

5 As for the spacer group Sp in formula I, Ia and Ib all groups can be used that are known for this purpose to the skilled in the art. The spacer group Sp is preferably linked to the polymerizable group P by an ester or ether group or a single bond. The spacer group Sp is preferably a linear or branched alkylene group having 1 to 20 C
10 atoms, in particular 1 to 12 C atoms, in which, in addition, one or more non-adjacent CH₂ groups may be replaced by -O-, -S-, -NH-, -N(CH₃)-, -CO-, -O-CO-, -S-CO-, -O-COO-, -CO-S-, -CO-O-, -CH(halogen)-, -CH(CN)-, -CH=CH- or -C≡C-.

15 Typical spacer groups Sp are for example -(CH₂)_o-, -(CH₂CH₂O)_r-CH₂CH₂-, -CH₂CH₂-S-CH₂CH₂- or -CH₂CH₂-NH-CH₂CH₂-, with o being an integer from 2 to 12 and r being an integer from 1 to 3.

20 Preferred spacer groups Sp are ethylene, propylene, butylene, pentylene, hexylene, heptylene, octylene, nonylene, decylene, undecylene, dodecylene, octadecylene, ethyleneoxyethylene, methyleneoxybutylene, ethylene-thioethylene, ethylene-N-methyl-iminoethylene and 1-methylalkylene, for example.

25 In the event that R is a group of formula P-Sp-X- or P-Sp- respectively, the spacer groups on each side of the mesogenic core may be identical or different.

30 In particular preferred are compounds of formula I wherein n is 1.

In another preferred embodiment, the inventive compensator is obtained by copolymerizing mixtures comprising compounds of formula I wherein n is 0 and compounds of formula I wherein n is 1.

35 Typical examples representing polymerizable mesogenic compounds of the formula I can be found in WO 93/22397; EP 0 261 712; DE 195

04 224; DE 44 08 171 or DE 44 05 316. The compounds disclosed in these documents, however are to be regarded merely as examples that should not limit the scope of this invention.

5 Furthermore, typical examples representing polymerizable mesogenic compounds are shown in the following list of compounds, which is, however, to be understood only as illustrative without limiting the scope of the present invention:

10

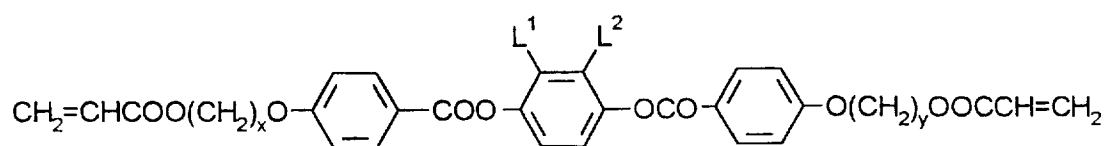

15

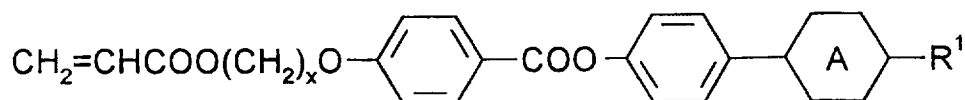
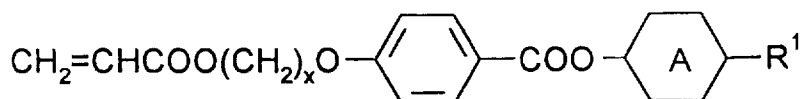

20

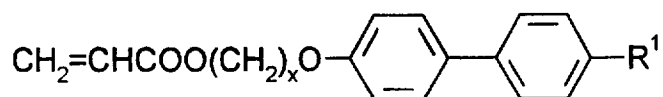

25

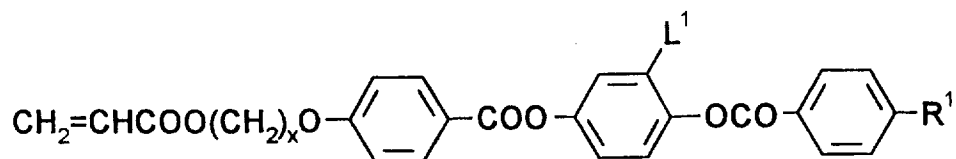

30

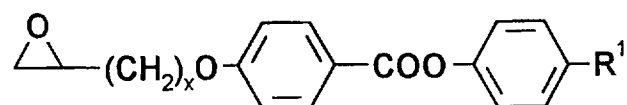
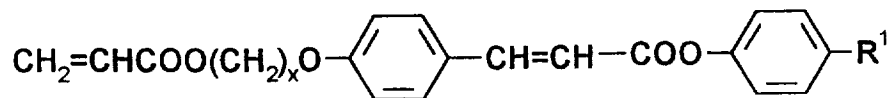

35

5 In these compounds x and y are each independently 1 to 12, A is a 1,4-phenylene or 1,4-cyclohexylene group, R¹ is halogen, cyano or an optionally halogenated alkyl or alkoxy group with 1 to 12 C atoms and L¹ and L² are each independently H, F, Cl, CN, or an optionally halogenated alkyl, alkoxy or alkanoyl group with 1 to 7 C atoms.

10 The polymerizable mesogenic compounds disclosed in the foregoing and the following can be prepared by methods which are known per se and which are described in the documents cited above and, for example, in standard works of organic chemistry such as, for example, Houben-Weyl, Methoden der organischen Chemie, Thieme-Verlag, Stuttgart.

15 As mentioned above, the properties of an inventive optical retardation film, like e.g. mesogen orientation and film structure, temperature stability and optical performance, can easily be adjusted to the desired specification by varying the composition of the polymerizable mesogenic material.

20 One possible way to adjust the alignment profile in the direction perpendicular to the film plane is the appropriate selection of the ratio of monoreactive mesogenic compounds, i.e. compounds with one polymerizable group, and direactive mesogenic compounds, i.e. compounds with two polymerizable groups.

25 For a highly splayed film structure, preferably the ratio of mono- to direactive mesogenic compounds should be in the range of 6:1 to 1:2, preferably 3:1 to 1:1, especially preferably about 3:2.

30 Another effective means to adjust the desired splay geometry is to use a defined amount of dielectrically polar reactive mesogens in the polymerizable mesogenic mixture. These polar reactive mesogens can be either monoreactive or direactive. They can be either dielectrically positive or negative. Most preferred are dielectrically
35 positive and monoreactive mesogenic compounds.

The amount of the polar compounds in the polymerizable mesogenic mixture is preferably 1 to 80 %, especially 3 to 60 %, in particular 5 to 40 % by weight of the total mixture.

- 5 Polar compounds bear one or more polar groups. Preferably these groups are selected from terminal or lateral end groups like CN, F, Cl, OCF₃, OCF₂H, OC₂F₅, CF₃, OCN or SCN, or from bridge groups like -COO-, -OCO-, -O-, -S-, -OCH₂-, -CH₂O-, -OCOO-, -COO-CH=CH- or -CF₂=CF₂-. Very preferably these groups are selected from CN, F, Cl
10 and OCF₃.

Furthermore, these polar compounds preferably have a high absolute value of the dielectric anisotropy $\Delta\epsilon$, which is typically higher than 1.5. Thus, dielectrically positive compounds preferably exhibit $\Delta\epsilon > 1.5$ and
15 dielectrically negative polar compounds preferably exhibit $\Delta\epsilon < -1.5$. Very preferred are dielectrically positive polar compounds with $\Delta\epsilon > 3$, in particular with $\Delta\epsilon > 5$.

In a preferred embodiment of the present invention, the optical
20 retardation film is obtainable from a mixture of a polymerizable mesogenic material comprising the following components

- a1) 10 to 99 % by weight of at least one mesogen according to
25 formula I having one polymerizable functional group,
a2) 0 to 70 % by weight of at least one mesogen according to formula I having two or more polymerizable functional groups,
b) 0.01 to 5 % by weight of an initiator,
30

Mixtures according to this preferred embodiment are preferred that
comprise

- a1A) 10 to 65 %, preferably 15 to 50 % by weight of at least one
35 polymerizable mesogen of formula I having one

- 35 -

polymerizable group, wherein R is an alkyl or alkoxy group with 1 to 12 C atoms,

- 5 a1B) 5 to 40 %, preferably 8 to 30 % by weight of at least one polymerizable mesogen of formula I having one polymerizable group, wherein R is CN, F, Cl or a halogenated alkyl or alkoxy group with 1 to 12 C atoms,
- 10 a2) 2 to 90 %, preferably 5 to 60 % by weight of at least one polymerizable mesogen of formula I having two polymerizable groups, wherein R has one of the meanings of P-(Sp-X)_n.
- b) 0.01 to 5 % by weight of an initiator.

15 Very preferred are mixtures according to this particularly preferred embodiment wherein the ratio of components a1A to a1B to a2 is in the range of 2:1:2.

20 Further preferred are mixtures according to this particularly preferred embodiment that comprise two to eight, in particular two to six, most preferably two to four different polymerizable mesogens of components a1A and a1B.

25 In the mixtures comprising two or more different mesogens according to formula I having one polymerizable functional group as described above, preferably each of the different mesogens according to formula I is different in at least one of the groups P, Sp, X, A¹, A², A³, Z¹, Z² and R from each other of the mesogens.

30 Furthermore, it has been found that when using monoreactive unpolar compounds, like e.g. compounds of formula Ia

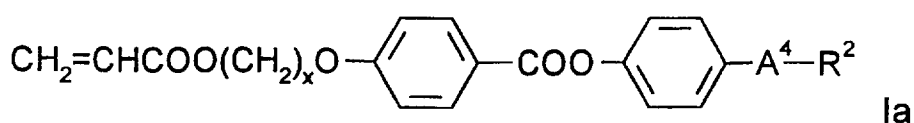

wherein x is 1 to 12, R² is C₁₋₁₂ alkyl or alkoxy, and

A⁴ is denoting 1,4-phenylene, trans-1,4-cyclohexylene or a single bond, preferably 1,4-cyclohexylene,

5 in a defined amount, the alignment profile and the tilt angle of the inventive optical retardation film can easily be adjusted to the desired specification.

10 For example, when preparing an optical retardation film as described above from a polymerizable mesogenic mixture comprising monoreactive unpolar compounds, e.g. compounds of formula Ia, together with direactive compounds and dielectrically positive polar monoreactive compounds of formula I, the tilt angle of the film is increasing with increasing amount of the monoreactive unpolar compounds.

15 In a preferred embodiment of the present invention, the polymerizable mesogenic mixture comprises 2 to 30 %, preferably 5 to 25 % by weight of compounds of formula Ia.

20 In another preferred embodiment, the polymerizable mesogenic mixture comprises 15 to 60 %, preferably 20 to 55 % by weight of compounds of formula Ia.

25 In another preferred embodiment, the polymerizable mesogenic mixture comprises 45 to 90 %, preferably 50 to 85 % by weight of compounds of formula Ia.

30 Without further elaboration one skilled in the art can, using the preceding description, utilize the present invention to its fullest extent. The following examples are, therefore, to be construed as merely illustrative and not limitative of the remainder of the disclosure in any way whatsoever.

35 In the foregoing and in the following examples, unless otherwise indicated, all temperatures are set forth uncorrected in degrees Celsius and all parts and percentages are by weight. The following

- 37 -

abbreviations are used to illustrate the liquid crystalline phase behaviour of the compounds:

5 K = crystalline; N = nematic; S = smectic; Ch = cholesteric; I = isotropic. The numbers between these symbols indicate the phase transition temperatures in degree Celsius.

Example 1

10 The following polymerizable mixture was formulated

15	compound (1)	38.9 %
	compound (2)	38.9 %
	compound (3)	19.2 %
	Irgacure 907	3.0 %

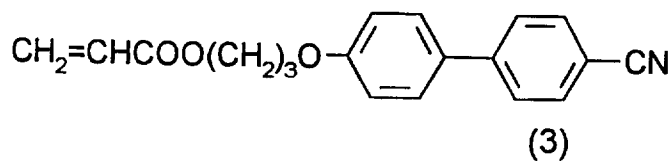
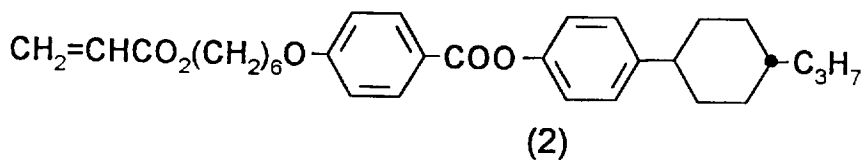
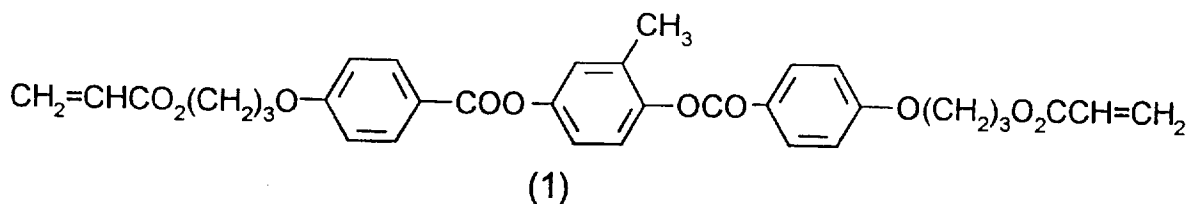

35 Irgacure 907 is a commercially available photoinitiator (Ciba Geigy AG) of the following formula

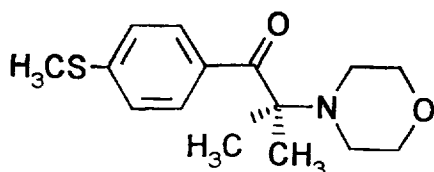

- 38 -

5 In order to prepare an optical retardation film, a solution of 12 % by weight of the above given polymerizable mixture in toluene is coated onto a TAC film (Lonza triphan type 91) that has been rubbed with a velvet coated bar unidirectionally at a length of 500 mm. The thickness of the coated solution is 6 μm . The toluene is evaporated to give a 0.7 μm thick layer of the above given polymerizable mixture. The layer is then polymerized by irradiation with UV light of 254 nm with an irradiance of 1500 mW/cm².

10

The rubbing, coating and curing process is then repeated on the other side of the TAC film, wherein the rubbing of the TAC substrate is carried out in the same direction as in the first step. A polymer film is obtained that can be used as an optical retardation film.

15

Use Example A

20 The retardation of the optical retardation film of example 1 was measured using an Olympus BX-50 polarizing microscope equipped with a quartz Berek type compensator and a tilting (- 60 ° to + 60 °) and rotating (0 to 360 °) stage.

25 The retardation of the optical retardation film of example 1 is 100 nm, measured at a wavelength of 550 nm and normal incidence.

To compare the performance of the inventive optical retardation film with retardation films of prior art, the measurement described above was repeated with the following retardation films:

30

- 1) a retardation film consisting of stretched polyvinylalcohol (PVA) available from Polatechno (17140 T),
- 2) a retardation film consisting of stretched polycarbonate (PC),

35

- 3) a retardation film consisting of a polymerized mesogenic material with planar alignment, comprising compounds similar to those of formula I of the present invention.

5 The measurement was carried out at different wavelengths of incident light and with the viewing angle varying in directions parallel and perpendicular to the major optical axis of the retardation film, which corresponds to the direction of orientation of the polymerized mesogenic material or, in case of the stretched PVA and PC films, the stretch direction.

10 Figure 3a shows the retardation versus viewing angle at a wavelength of 550 nm for the optical retardation film of example 1 (curve 4), a PVA film (1), a PC film (2) and a film consisting of polymerized mesogenic material with planar alignment (3), wherein the direction of observation is parallel to the major optical axis of the films.

15 Figure 3b shows the retardation versus viewing angle at a wavelength of 550 nm for the optical retardation film of example 1 (curve 4), a PVA film (1), a PC film (2) and a film consisting of polymerized mesogenic material with planar alignment (3), wherein the direction of observation is perpendicular to the major optical axis of the films.

20 The inventive optical retardation film exhibits a retardation with a significantly low viewing angle dependence, in particular when compared to a stretched PVA film.

25 Figure 4 shows the normalized retardation versus wavelength of an inventive optical retardation film (curve 4) compared the state of the art optical retardation films 1, 2 and 3 mentioned above (curve 1 to 3).

30 From figure 4 it can be seen that the wavelength dependence of the retardation of an inventive optical retardation film is very low and is second only to the PVA film, which, however, shows an unfavourable viewing angle dependence, as depicted in figure 3a/b.

35

- 40 -

Thus, when taking the combination of wavelength dependence and viewing angle dependence of the retardation, the inventive optical retardation film shows superior behaviour compared to state of the art optical retardation films. Such a film is therefore suitable for the use in a liquid crystal display device.

Example 2

The following polymerizable mixture was formulated

compound (1)	38.4 %
compound (2)	38.4 %
compound (4)	19.2 %
Irgacure 907	4.0 %

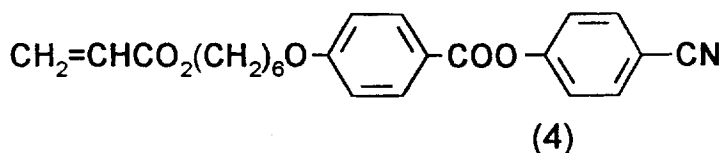

An optical retardation film is prepared from a solution of 20 % by weight of the above given polymerizable mixture in toluene as described in example 1.

Use Example B

The retardation of the optical retardation film of example 1 was measured as described in example A. The results are depicted in figure 5, that shows the retardation versus viewing angle at a wavelength of 550 nm, with the direction of observation being parallel (curve a) and perpendicular (curve b) to the major optical axis of the film. For a wavelength of 550 nm and normal incidence the retardation is 100 nm.

The optical performance of the inventive retardation film was determined when used together with a broad band cholesteric circular reflective polarizer that is consisting of a polymerized mixture comprising chiral and achiral reactive mesogenic compounds. The reflective polarizer exhibits a cholesteric structure with planar orientation and multiple pitch lengths of the cholesteric helix, and has a broad wavelength reflection band with a bandwidth of 300 nm.

The luminance of light from a commercial LCD backlight passing through an assembly with the circular reflective polarizer and the inventive optical retardation film of example 2 was measured using a Minolta CS-100 colour camera at a range of viewing angles (-60° to $+60^\circ$). The experiment was repeated with a similar assembly, wherein the inventive optical quarter wave retardation film was replaced by one of the state of the art retardation films 1, 2 and 3 described in example A.

Figure 6a and 6b depict the measurement results for observation parallel (6a) and perpendicular (6b) to the major optical axis of the films.

Curve 5 in figure 6a/b depicts the luminance of the LCD backlight and the circular reflective polarizer alone. Curves 1 to 4 show the luminance of the LCD backlight and a combination of the circular reflective polarizer together with the inventive optical retardation film (curve 4) or one of the state of the art retardation films 1 to 3 (curve 1 to 3, each corresponding to the film with the same number).

When viewing in a direction parallel to the major optical axis of the films, the luminance of an inventive assembly comprising the inventive optical retardation film of example 2 is slightly lower than that of the assembly comprising the state of the art films 1 to 3.

However, when viewing in a direction perpendicular to the major optical axis of the films, the luminance of an inventive assembly comprising the inventive optical retardation film of example 2 is slightly lower than that of the assembly comprising the state of the art

- 42 -

films 1 to 3 for small viewing angles, but higher for viewing angles larger than 30 degrees. The cross-over angle α_C for an inventive assembly is increased.

5 The optical retardation film and the broadband circular reflective polarizer in figure 6a/b according to example B are not optically coupled. If they are laminated together, or if the circular reflective polarizer is prepared by polymerization of a mixture of reactive cholesteric mesogenic compounds using the optical retardation film
10 as a substrate, the cross over angle α_C can be further increased.

The results of experiments according to example A and B clearly demonstrate the improved properties of an inventive optical retardation film compared to an optical retardation film of the state of
15 the art, especially when used in combination with a broadband cholesteric circular reflective polarizer.

The preceding examples can be repeated with similar success by substituting the generically or specifically described reactants and/or
20 operating conditions of this invention for those used in the preceding examples.

From the foregoing description, one skilled in the art can easily ascertain the essential characteristics of this invention, and without
25 departing from the spirit and scope thereof, can make various changes and modifications of the invention to adapt it to various usages and conditions.

30

35

Patent Claims

1. An optical retardation film comprising two layers of an anisotropic polymer that are adjacent to each other or adjacent to both sides of a common substrate, characterized in that each layer exhibits a tilted structure with an optical symmetry axis having a tilt angle θ relative to the plane of the layer.
2. An optical retardation film according to claim 1 that exhibits a tilted and splayed structure, wherein the tilt angle θ in each of said layers varies continuously in a direction normal to the layer, starting from a minimum value θ_{\min} at the side of the layer facing the other layer or, if present, the common substrate, and ranging to a maximum value θ_{\max} on the opposite side of the layer, or vice versa.
3. An optical retardation film according to claim 2, wherein said minimum tilt angle θ_m in each layer is substantially zero degrees.
4. An optical retardation film according to claim 1, 2 or 3, wherein the projection of the optical symmetry axis of the first layer into the plane of the layer and the projection of the optical symmetry axis of the second layer into the plane of the layer are twisted relative to each other at an angle ρ in the plane of the interface between the layers, said angle ρ being preferably from 0 to 90 degrees.
5. An optical retardation film according to claim 4, wherein said angle ρ is substantially 0 degrees.
6. An optical retardation film according to any of the claims 1 to 5, characterized in that the retardation of the optical retardation film is from 50 to 250 nm.
7. An optical retardation film according to any of the claims 1 to 6 that is obtainable by a method comprising the following steps

- 44 -

- 5
- 10
- 15
- 20
- 25
- 30
- 35
- A) coating a mixture comprising
 - a) a polymerizable mesogenic material comprising at least one polymerizable mesogen having at least one polymerizable functional group,
 - b) an initiator, and
 - c) optionally a solventon a substrate or between a first and a second substrate in form of a layer,
 - B) aligning the polymerizable mesogenic material in the coated layer into a tilted and optionally a splayed structure.
 - C) polymerizing said mixture of a polymerizable mesogenic material by exposure to heat or actinic radiation,
 - D) optionally removing the substrate or, if two substrates are present, one or two of the substrates from the polymerized material, and
 - E) repeating the steps A), B), C) and optionally step D) at least one more time.
8. An optical retardation film obtainable according to claim 7, characterized in that the steps A), B) and C) are carried out on both sides of a common substrate.
9. An optical retardation film obtainable according to claim 7 or 8, characterized in that the mixture of the polymerizable mesogenic material comprises at least one polymerizable mesogen having one polymerizable functional group and at least one

- 45 -

polymerizable mesogen having two or more polymerizable functional groups.

- 5 10. An optical retardation film according to any of the claims 7 to 9, characterized in that the polymerizable mesogens are compounds of formula I



10 wherein

P is a polymerizable group,

15 Sp is a spacer group having 1 to 20 C atoms,

X is a group selected from -O-, -S-, -CO-, -COO-, -OCO-, -OCOO- or a single bond,

20 n is 0 or 1,

MG is a mesogenic or mesogeneity supporting group, preferably selected according to formula II

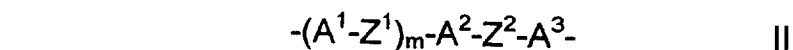

25

wherein

30 A¹, A² and A³ are independently from each other 1,4-phenylene in which, in addition, one or more CH groups may be replaced by N, 1,4-cyclohexylene in which, in addition, one or two non-adjacent CH₂ groups may be replaced by O and/or S, 1,4-cyclohexenylene or naphthalene-2,6-diyl, it being possible for all these groups to be unsubstituted,
 35 mono- or polysubstituted with halogen, cyano or nitro groups or alkyl, alkoxy or alkanoyl groups having 1 to

- 46 -

7 C atoms wherein one or more H atoms may be substituted by F or Cl,

5 Z^1 and Z^2 are each independently -COO-, -OCO-,
-CH₂CH₂-, -OCH₂-, -CH₂O-, -CH=CH-, -C≡C-,
-CH=CH-COO-, -OCO-CH=CH- or a single bond,

m is 0, 1 or 2, and

10 R is an alkyl radical with up to 25 C atoms which may be
unsubstituted, mono- or polysubstituted by halogen or CN,
it being also possible for one or more non-adjacent CH₂
groups to be replaced, in each case independently from
one another, by -O-, -S-, -NH-, -N(CH₃)-, -CO-, -COO-,
15 -OCO-, -OCO-O-, -S-CO-, -CO-S- or -C≡C- in such a
manner that oxygen atoms are not linked directly to one
another, or alternatively R is halogen, cyano or has
independently one of the meanings given for P-(Sp-X)_n.

20 11. A means to produce substantially linear polarized light,
comprising a broadband circular reflective polarizer and an
optical retardation film according to any of the claims 1 to 10.

25 12. A liquid crystal display comprising a display cell and an optical
retardation film according to any of the claims 1 to 10.

13. A liquid crystal display comprising a display cell and a means to
produce substantially linear polarized light according to claim 11.

30

35

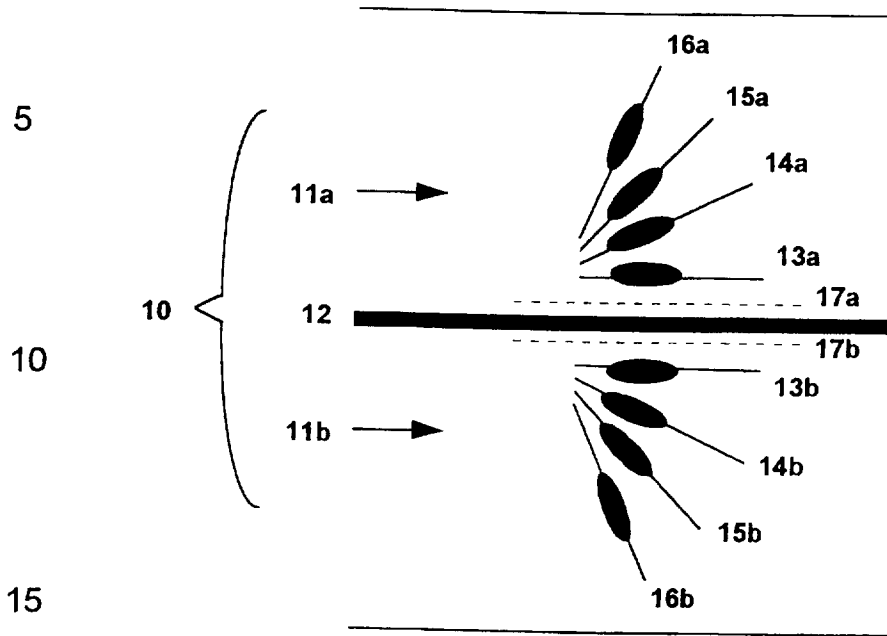

Figure 1a

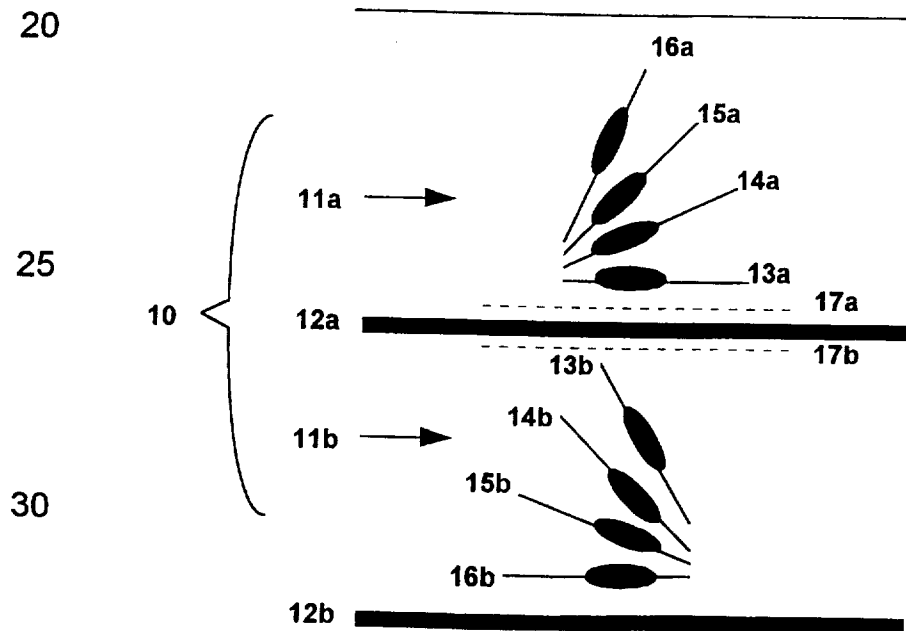

Figure 1b

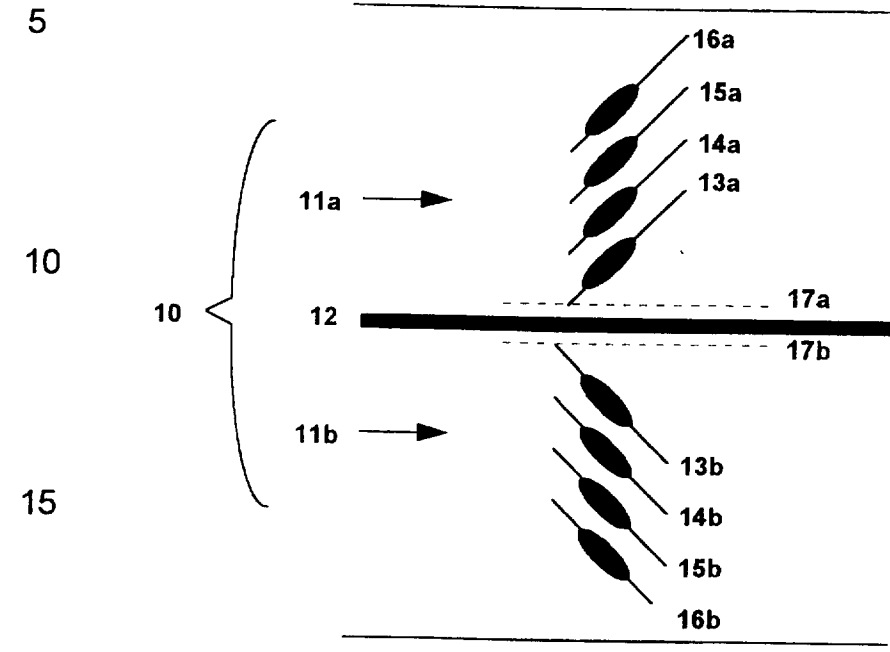

Figure 1c

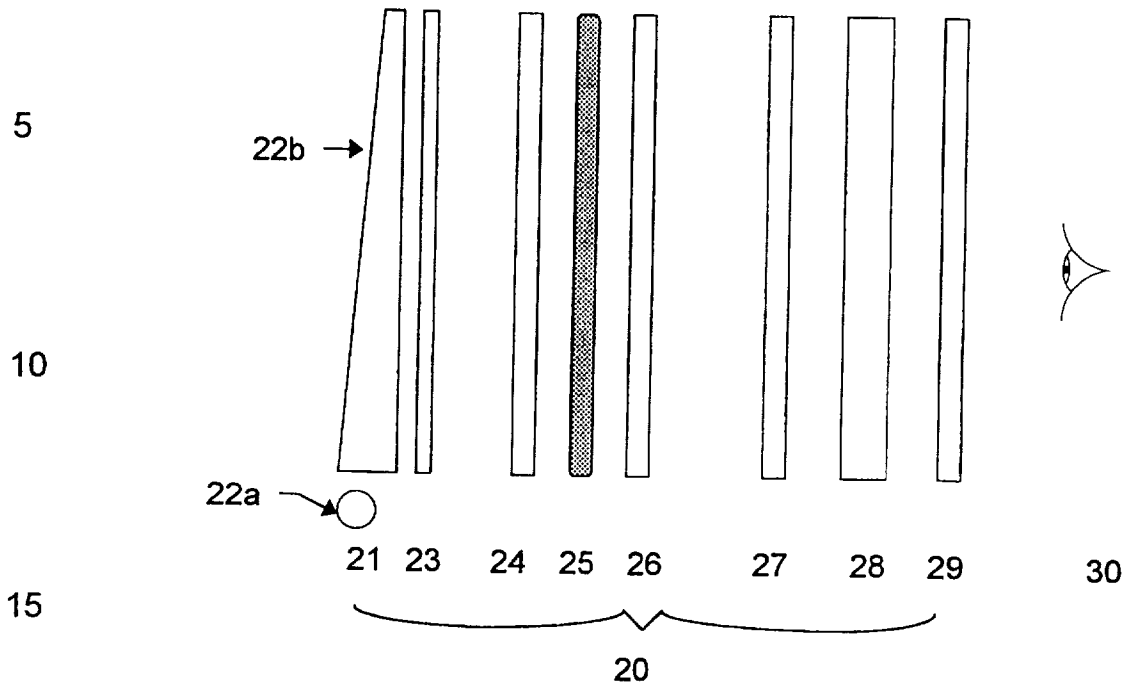

Figure 2a

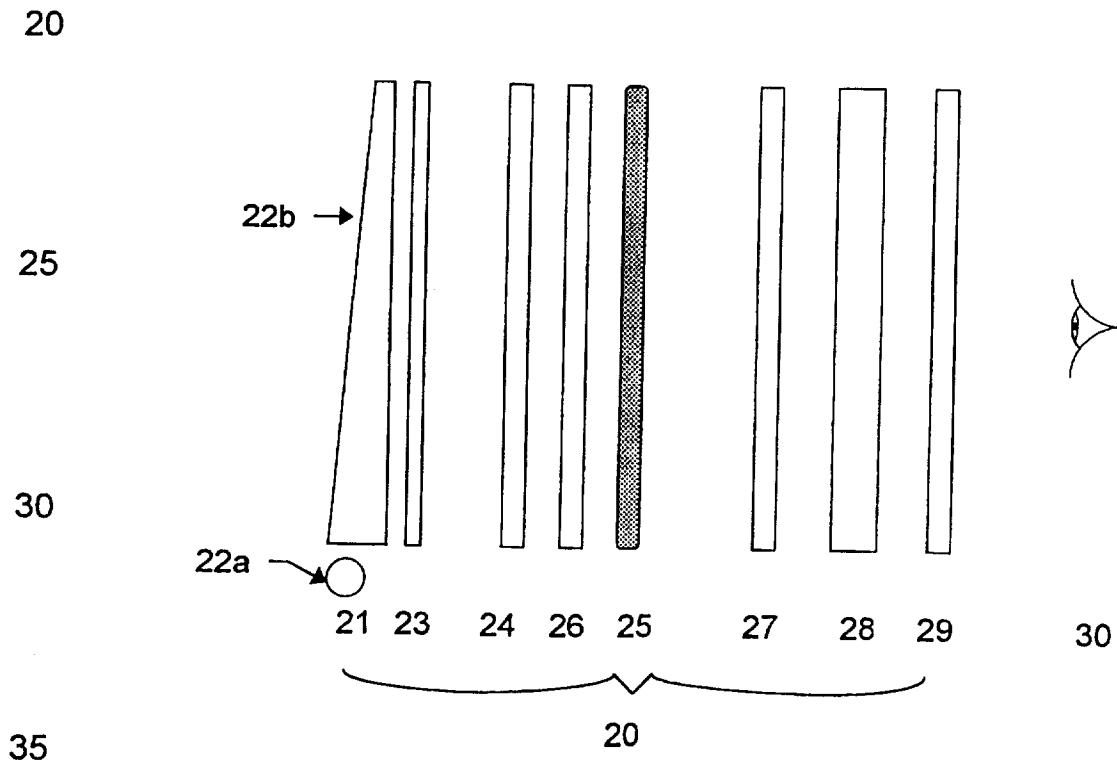

Figure 2b

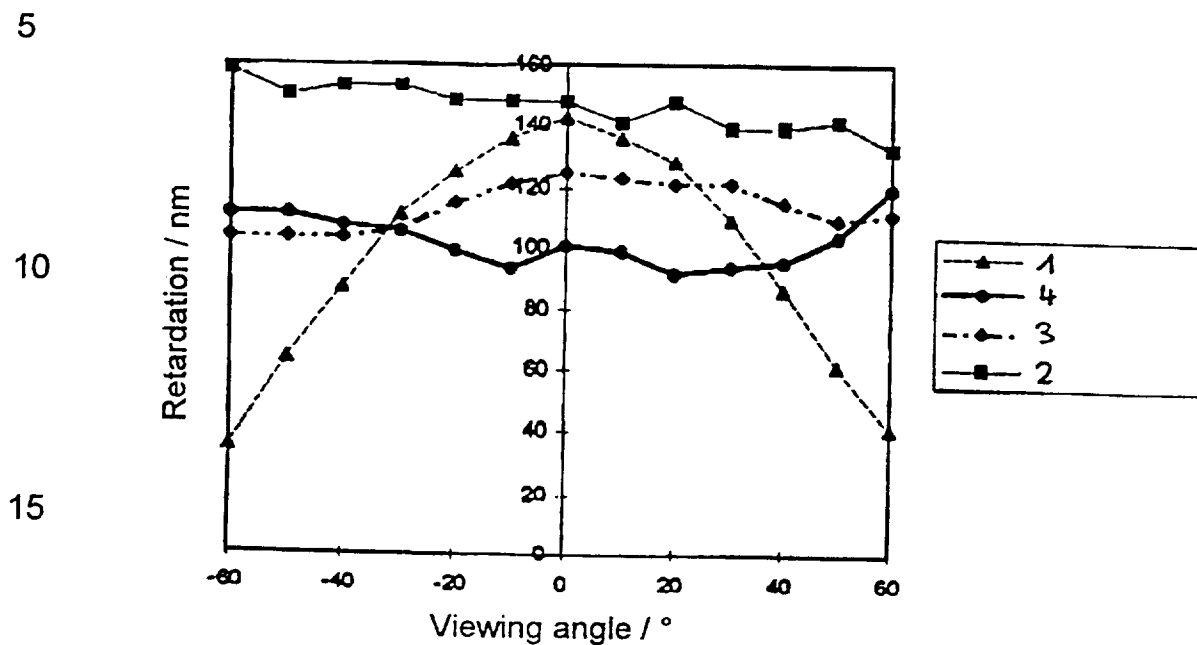

Figure 3a

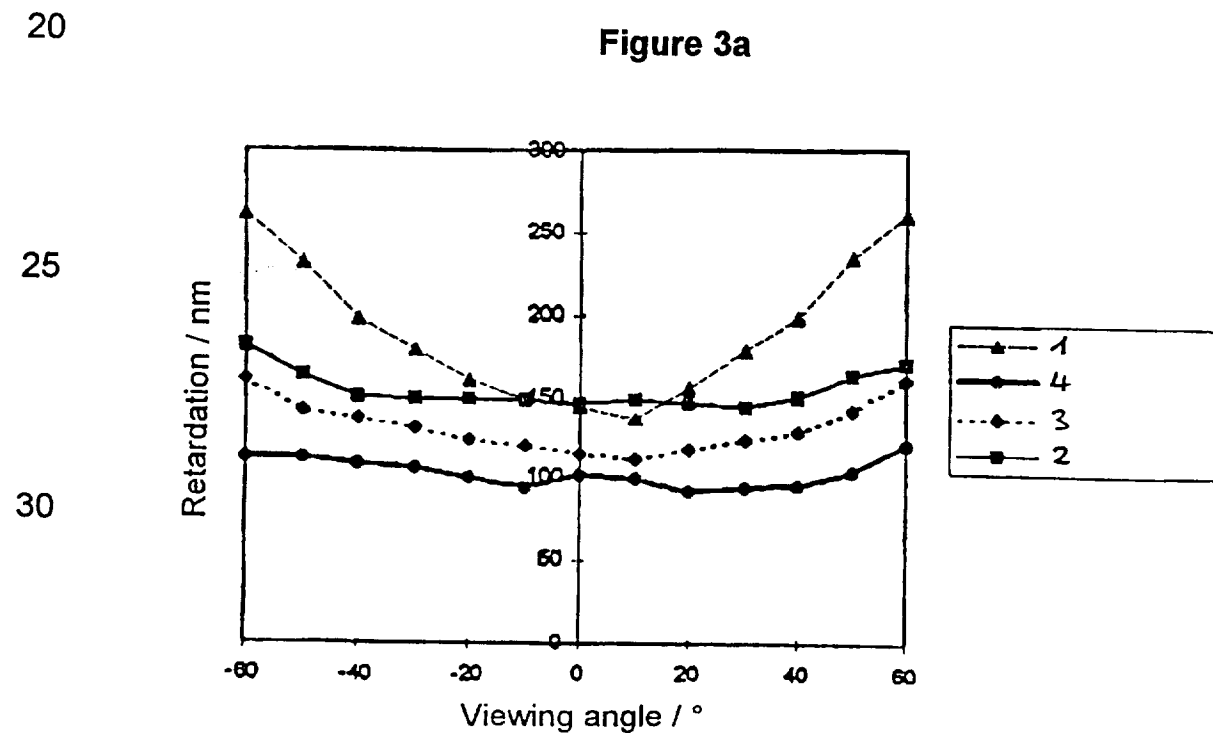

Figure 3b

- 5/7 -

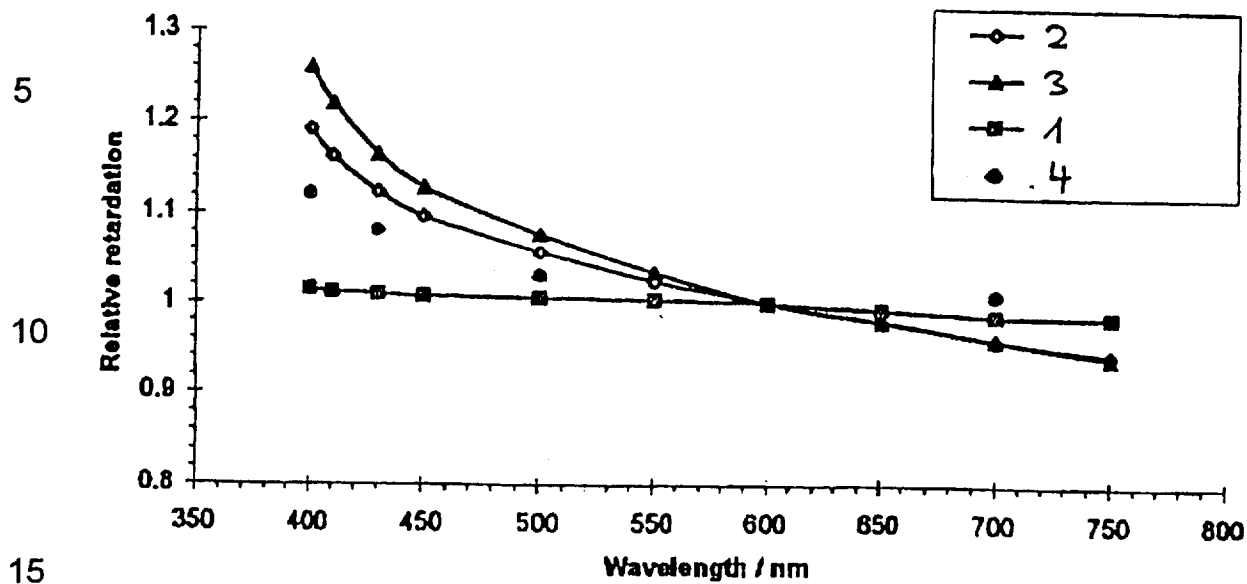

Figure 4

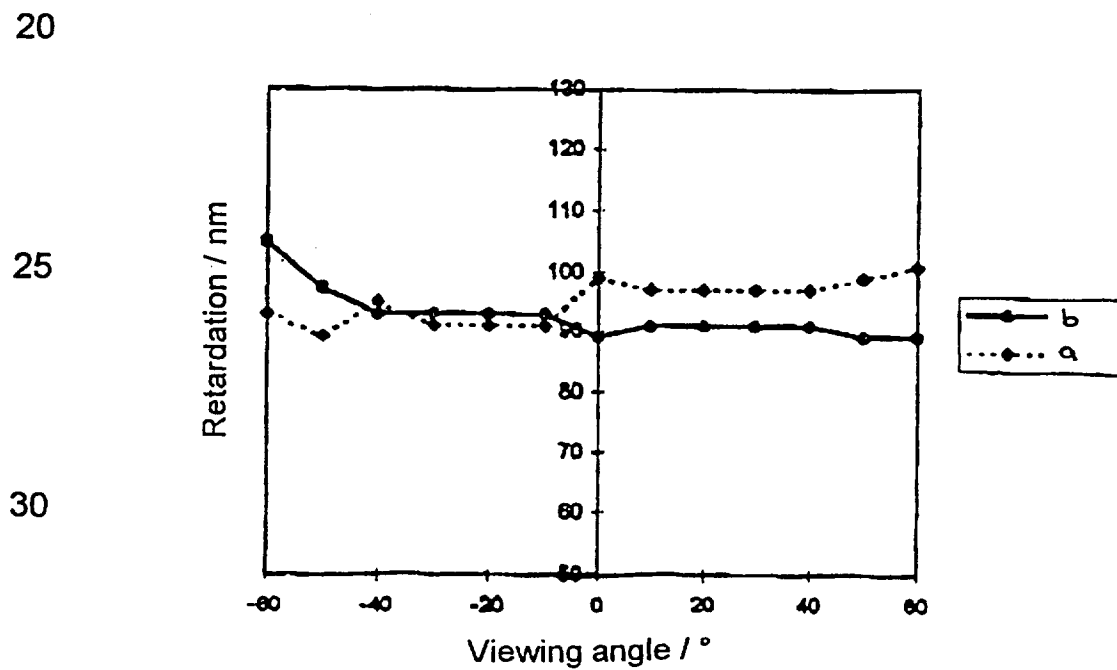

Figure 5

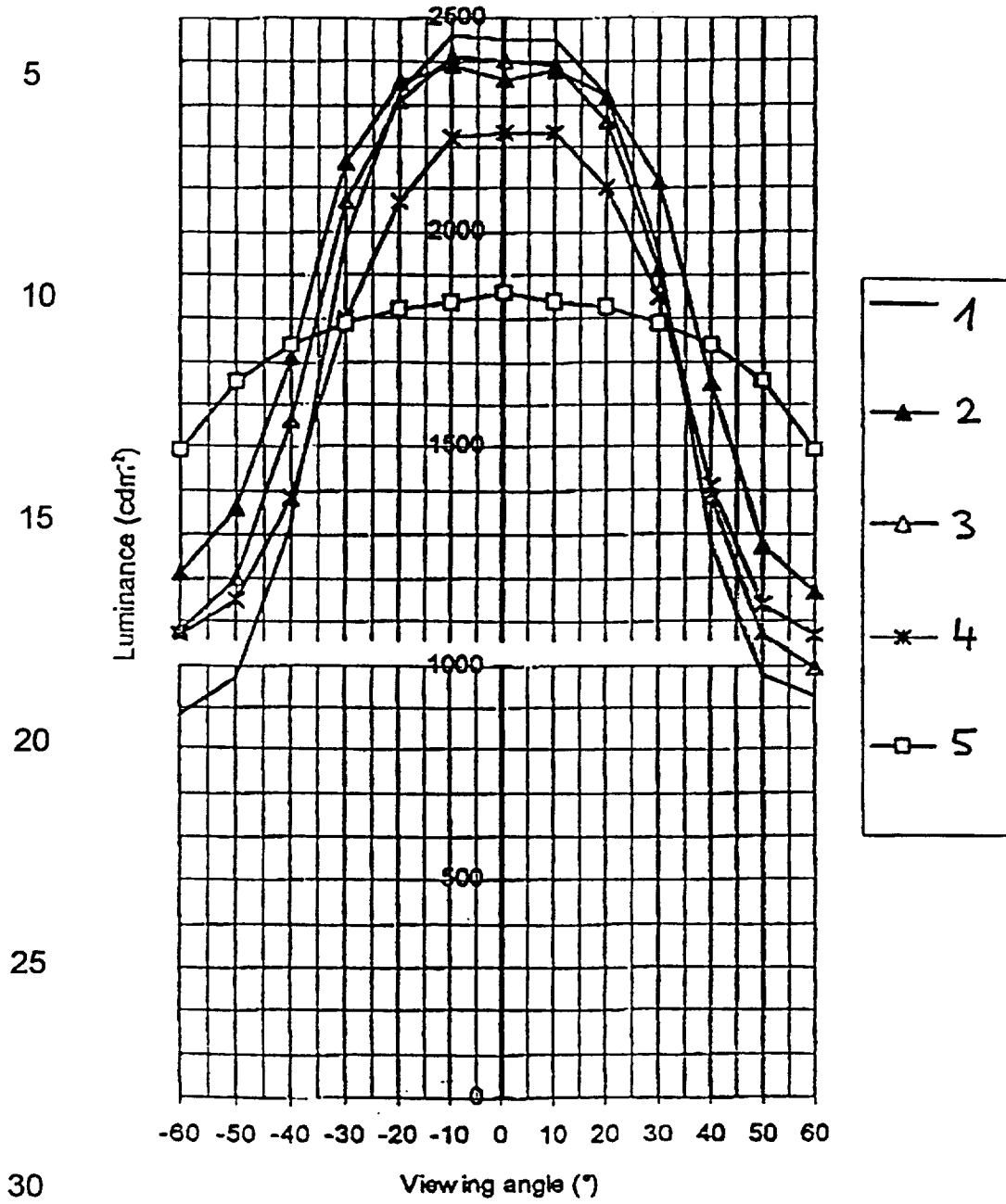

Figure 6a

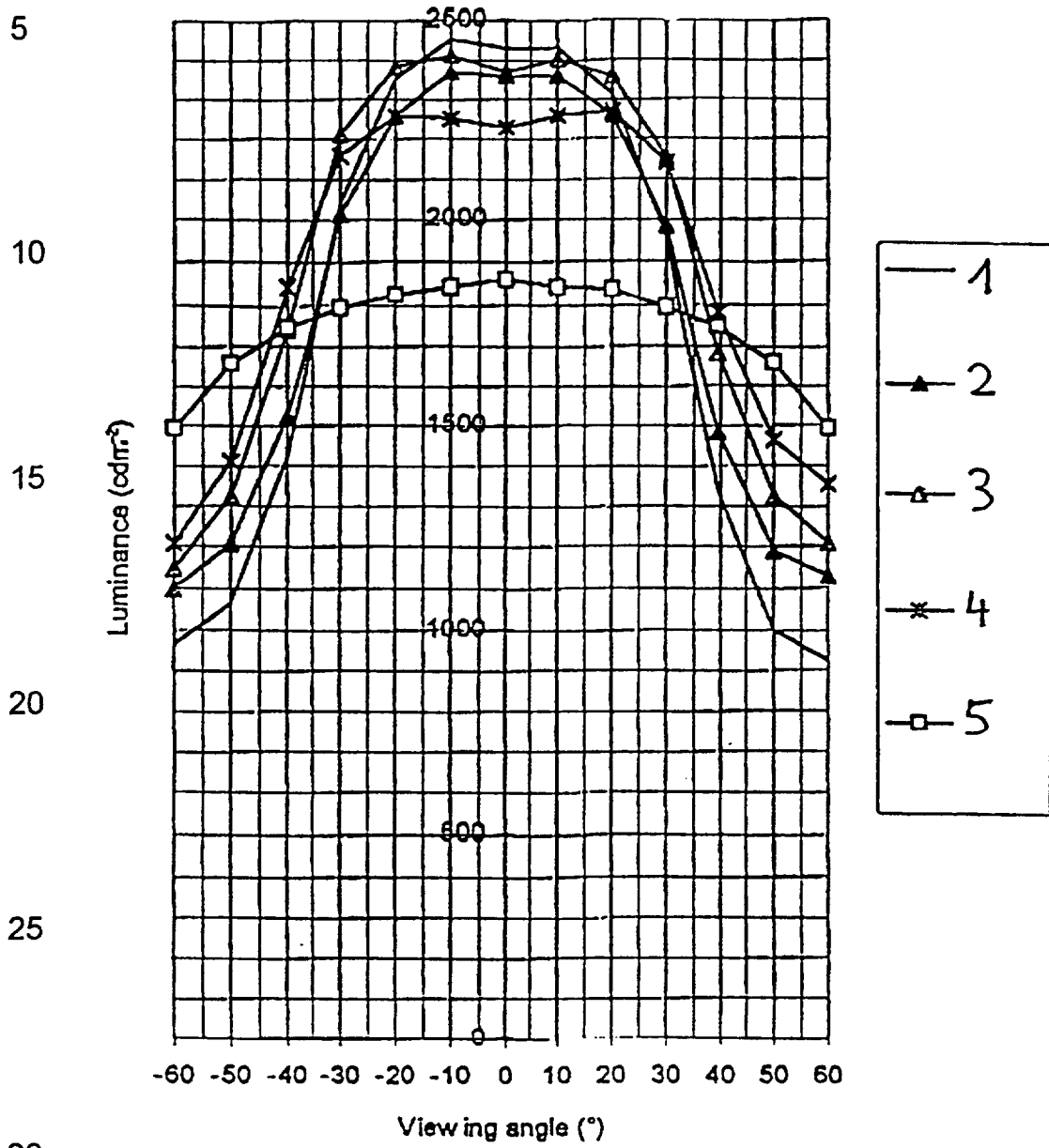

Figure 6b

INTERNATIONAL SEARCH REPORT

Inter. Application No

PCT/EP 97/04827

A. CLASSIFICATION OF SUBJECT MATTER
 IPC 6 G02B5/30 G02F1/1335

According to International Patent Classification (IPC) or to both national classification and IPC

B. FIELDS SEARCHED

Minimum documentation searched (classification system followed by classification symbols)
 IPC 6 G02B G02F

Documentation searched other than minimum documentation to the extent that such documents are included in the fields searched

Electronic data base consulted during the international search (name of data base and, where practical, search terms used)

C. DOCUMENTS CONSIDERED TO BE RELEVANT

Category	Citation of document, with indication, where appropriate, of the relevant passages	Relevant to claim No.
X	WO 96 10768 A (ROCKWELL INTERNATIONAL CORP) 11 April 1996	1,7,12
Y	see page 30, line 19 - line 27	11,13
A	see page 31 - page 33 see figure 14	2,4,5,9
Y	EP 0 606 940 A (PHILIPS ELECTRONICS NV) 20 July 1994	11,13
A	cited in the application	1
A	WO 96 10770 A (ROCKWELL INTERNATIONAL CORP) 11 April 1996	1,7, 11-13
	cited in the application see the whole document	
	-/--	

Further documents are listed in the continuation of box C.

Patent family members are listed in annex.

Special categories of cited documents:

- "A" document defining the general state of the art which is not considered to be of particular relevance
- "E" earlier document but published on or after the international filing date
- "L" document which may throw doubts on priority claim(s) or which is cited to establish the publication date of another citation or other special reason (as specified)
- "O" document referring to an oral disclosure, use, exhibition or other means
- "P" document published prior to the international filing date but later than the priority date claimed

- "T" later document published after the international filing date or priority date and not in conflict with the application but cited to understand the principle or theory underlying the invention
- "X" document of particular relevance; the claimed invention cannot be considered novel or cannot be considered to involve an inventive step when the document is taken alone
- "Y" document of particular relevance; the claimed invention cannot be considered to involve an inventive step when the document is combined with one or more other such documents, such combination being obvious to a person skilled in the art.
- "&" document member of the same patent family

Date of the actual completion of the international search

22 January 1998

Date of mailing of the international search report

29/01/1998

Name and mailing address of the ISA

European Patent Office, P.B. 5818 Patentlaan 2
 NL - 2280 HV Rijswijk
 Tel. (+31-70) 340-2040, Tx. 31 651 epo nl,
 Fax: (+31-70) 340-3016

Authorized officer

Ward, S

INTERNATIONAL SEARCH REPORT

International Application No

PCT/EP 97/04827

C.(Continuation) DOCUMENTS CONSIDERED TO BE RELEVANT		
Category	Citation of document, with indication, where appropriate, of the relevant passages	Relevant to claim No.
A	EP 0 628 847 A (NIPPON OIL CO LTD) 14 December 1994 see the whole document -----	1-3,7, 9-13

INTERNATIONAL SEARCH REPORT

Information on patent family members

International Application No

PCT/EP 97/04827

Patent document cited in search report	Publication date	Patent family member(s)	Publication date
WO 9610768 A	11-04-96	US 5619352 A	08-04-97
EP 0606940 A	20-07-94	CN 1095164 A JP 6281814 A US 5506704 A	16-11-94 07-10-94 09-04-96
WO 9610770 A	11-04-96	NONE	
EP 0628847 A	14-12-94	JP 6347742 A JP 7020434 A JP 7063916 A JP 7140326 A US 5460748 A US 5578243 A	22-12-94 24-01-95 10-03-95 02-06-95 24-10-95 26-11-96