

(19)  
(12)

(KR)  
(A)

(51) 。 Int. Cl.7  
G02F 1/133

(11)  
(43)

10-2005-0007115  
2005 01 17

(21) 10-2004-0033426  
(22) 2004 05 12

(30) JP-P-2003-00195648 2003 07 11 (JP)

(71) 가 가 997

(72) 997 가 가

997 가 가

997 가 가

(74)

:

(54) . . .

가 , TFT (10) , (11) TFT 2 (22)  
(22) (40) , TFT (10)  
(41) , (40) (22) (213) , (40) 가  
(40) , (41) (41)  
(70) , (70) (41)

3

, TFT, , , , , ,

1 TFT , .  
 2 TFT .  
 3 1 TFT , TFT  
 4 3 (24) .  
 5 .  
 6 .  
 7 2 TFT .  
 8 3 TFT .  
 9 4 TFT .  
 10 5 TFT .  
 11 TFT .  
 12 TFT .  
 13 TFT .

\* \*

10, 17, 18 : TFT 11 :

11i : 12 :

12i : 14 :

16 : 21 :

210 : 211 :

212 : 213 :

22 : 23 :

24 : 240 :

40 : 41 43 :

50 : 70 :

71 : Vgh :

Vgl :

, TFT(Thin Film Transistor) , TFT TFT

, TFT , . TFT (TFT)가 .

11 , TFT , 10 TFT , 20  
 , 30 . TFT (10) , (11) (11) (12)  
 (11) (12) TFT 13 , TFT 13 , G S가, (11) (12) (12)  
 TFT 13 , (14) .

(11) , (20) , TFT 13 (11)  
 (12) , (30) , TFT 13 , G Vgh  
 가 가 , 가 , TFT 13 , Vgl 가 , ( ) .  
 , TFT 13 (14) , (12) ( ) .

12 , TFT , 21  
 , 22 , 31 , 32 .

(21) (22) , 11 (20) (21) ,  
 (210) 가 (211), (212) (213)가 ,  
 Vgh Vgl .

(22) , IC (24)가 (23) TCP  
 (Tape Carrier Package) COF(Chip On Film) 가 , (21)  
 가 , Vgh Vgl , (11) Vgh 가  
 , (11) Vgl 가 .

가 , (31) (32) , 11 (30) .  
 (31) , (32) , IC (34) (33) (310) 가  
 , (31) , (12)

TFT , (20) 가, 가 (22)  
 . 가 , (30) 가, 가 (32)  
 . , TFT , .

13 , TFT , 40  
 41 42 TFT .

(40) , 12 (21) (31) , (32)  
 (400) , (40) , 12 (21)  
 (211 213) (31) .

Vgh Vgl , TFT (10) 41 , (40)  
 가 가 (22) , TFT (10) 42 , ( )  
 22) , (41, 42) , TFT (10) (22)

TFT , (21) (31) (40))  
 , TFT , , .  
 13 41 42 , TFT (10) (11) , ,  
 , TFT (10) , , (11)  
 , (22) (11) , 12  
 , 가 , .  
 , Vgl 가 , (14) , Vgl , (22)  
 , 가 가 (22) , ,  
 (24) , , 1 (24) , 1 ,

[ 1 ]

2001-228834

1 , (24) , , (22) , ,  
 , 가 , , 가 .  
 , , 1 , ,  
 , TFT 13 S G , (12)  
 , Vgl 가 (11) (11) , ,  
 , (22) , 가 , Vgl 가  
 (22) , , TFT  
 TFT , , 가 TFT  
 , , , ,  
 TFT , , ,  
 2 , TFT , ,  
 , TFT , ,  
 , 가 가 , ,  
 , ,



2, TFT, 1, (32), (40), (52), (22) 가, (40), (213), (70), (70)가, 13( )

(212) (40), (213)가, Vgh, (211), (32), (33), Tft, (10), Vgl, (40), (70), (32), (33), Tft, (10)

(22), Tft, (10), 41, 42, (22), Tft, (22), (10), 41, 42, (40), (24), (40), (22), Tft, (10), 41, 42, (22), (22), 42, (22)

(70), (40) 가 가, (22), (41)

1, 42, 16, (41, 42), (11) 가, (22), (41, 42), Tft, (10), (4)

(22), (11), Tft, (10), (11), (22), (11), (11i)가, (11i), (16), (22), 가, (12i), (32), (12) Tft, (10), (32), (22), (22)

4, 3, (24), (24), (24), (24), Vgh, Vgl, Vgh, (240), Vgl, (240), (11i)

5, 6, 가, 6, 가, 5, 가

RGB, 가, RGB, ( )

가, (22), Vgl

6, (70), Vgl, (213) 가 가, 60, 41, (22)

61 42 (22) ,62 ( (22) 가 . (22) )  
 , Vgl , , 가 , 가  
 , , 가 가 , (22) , Vgl (213) 가 , , 가  
 , (22) , (22) 가 .  
 , , (70) 100 300 (40)  
 , 200 (22) 가 ,  
 10 50 (40) 가 가 (22) , , (22)  
 , TFT , 200 (10) 가 (70) 100 , (70)  
 , Vgl 41 , ,  
 , (40) Vgl 41 TFT (10) (70) , ,  
 (213) (22) Vgl Vgl , , ,  
 ( 2)  
 1 , (40) , (213) (40)  
 , , ( )  
 7 , 가 2 TFT , TFT  
 , 70 , 71 ,  
 (40) , (70) (71)가 , (213)  
 (70) , (22) (71) , (71) (213) (22)  
 , (71) , (40) 가 가 (22) , (2)  
 ( 41)  
 , Vgl , Vgl (22) (22) ,  
 , , ,  
 ( 3)  
 , 1 (70) , (40) (70) , 2  
 , (71)  
 8 , 가 3 TFT , TFT  
 , (71) (40) , (71)가 , (213)  
 (22) (22)  
 , (71) , (40) 가 가 (22) , (22)  
 ( 41)

,  
 Vgl (213), (22), (71),  
 ( 4)  
 1 3, (23), (24), TCP COF (22),  
 , TFT  
 9, 가 4 TFT, TFT 17, TFT  
 TFT 17, (16) 가 (25, 35),  
 COG(Chip On Glass)  
 ACF(Anisotropy Conductive Film: ) 가,  
 (11i), TFT 17 (12i), (41, 42),  
 (25), TFT (10), TCP  
 , TFT  
 (25), TFT 17, 41, 42  
 (40), (25) (70), 1 3 (71) 가,  
 (25) COG TFT 17  
 , 1 3 가,  
 ( 5)  
 1 4, (22, 25) (40)  
 10, 가 5 TFT, TFT 18, (25) TFT  
 , 9  
 43, TFT 18, (25), (40)  
 (25), 43 TFT 18,  
 (25), 1 3 (40) 가, (11) (25)  
 ) (70), (71) 가, (40) ( )  
 가, (25) TFT 18, 1 4  
 , 가 TFT, TFT  
 , TFT (10, 15) COG, TCP COF, 9 10,



TFT

TFT

가 TFT

(57)

1.

TFT

2

TFT

가 가

TFT

2.

1

가 가

가,

TFT

3.

1

, TFT

TFT

4.

1

TFT

5.

1

TFT

6.

1

, TFT

TFT

7.  
1

가

TFT

8.  
7

TFT

9.  
1

, TFT

TFT

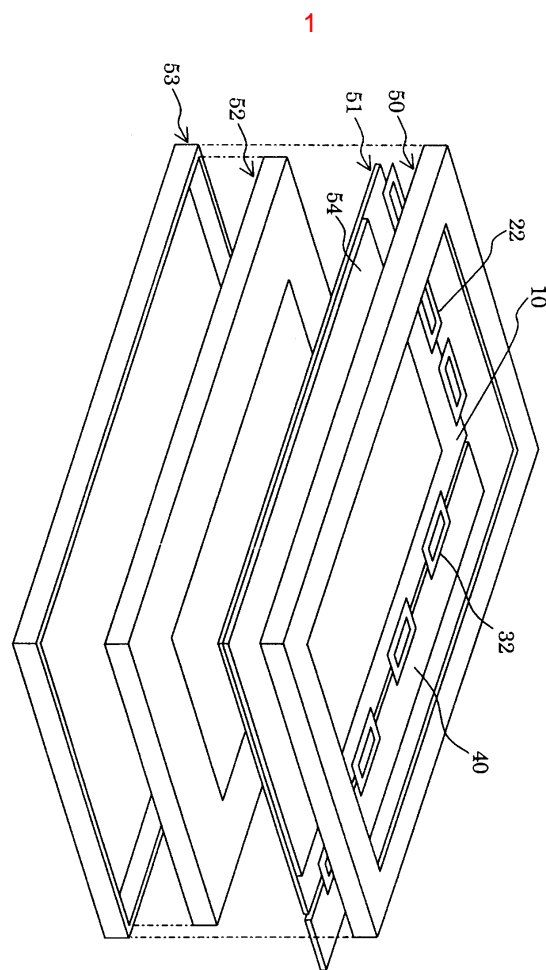

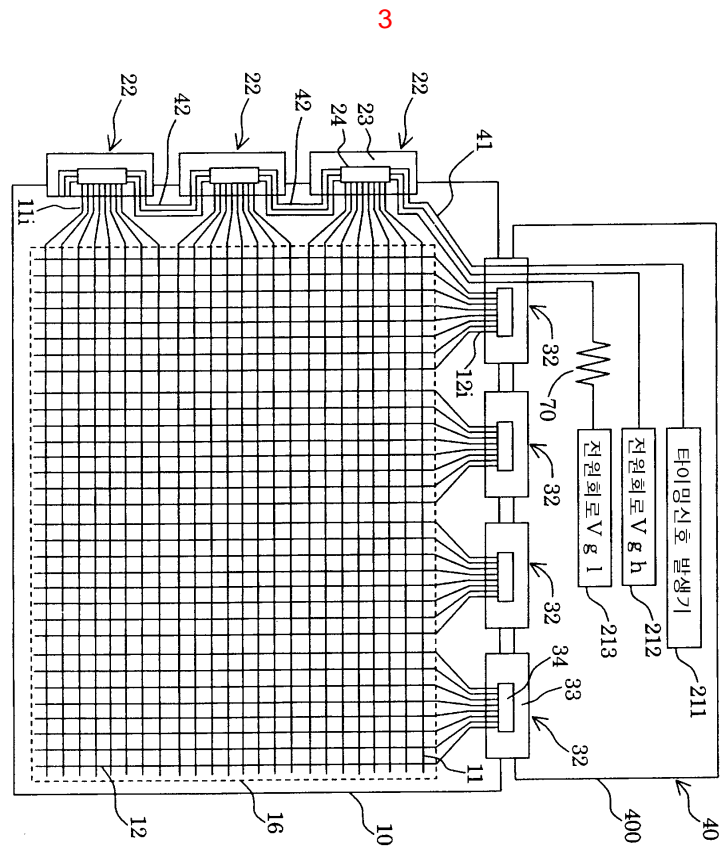
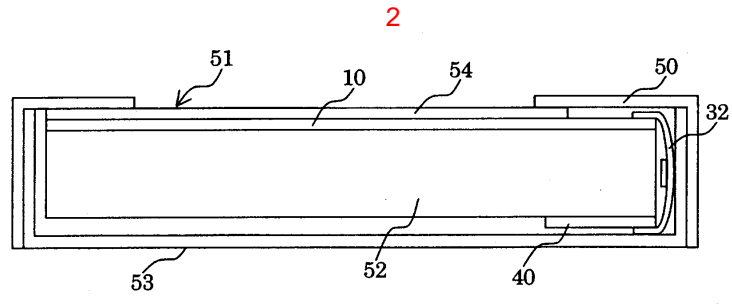

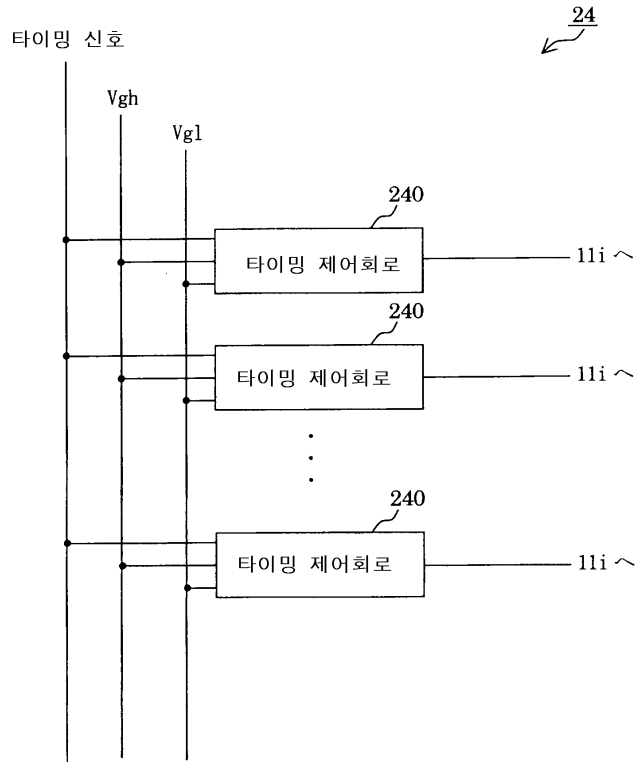

4



5

R	G	B	R	G	B	R	G	B	R	G	B
R	G	B	R	G	B	R	G	B	R	G	B
R	G	B	R	G	B	R	G	B	R	G	B
R	G	B	R	G	B	R	G	B	R	G	B

 검은색 표시  
 중간조 표시

6

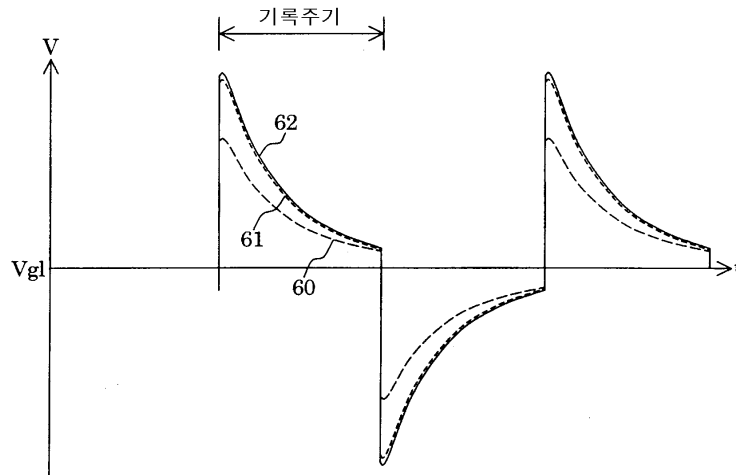

7

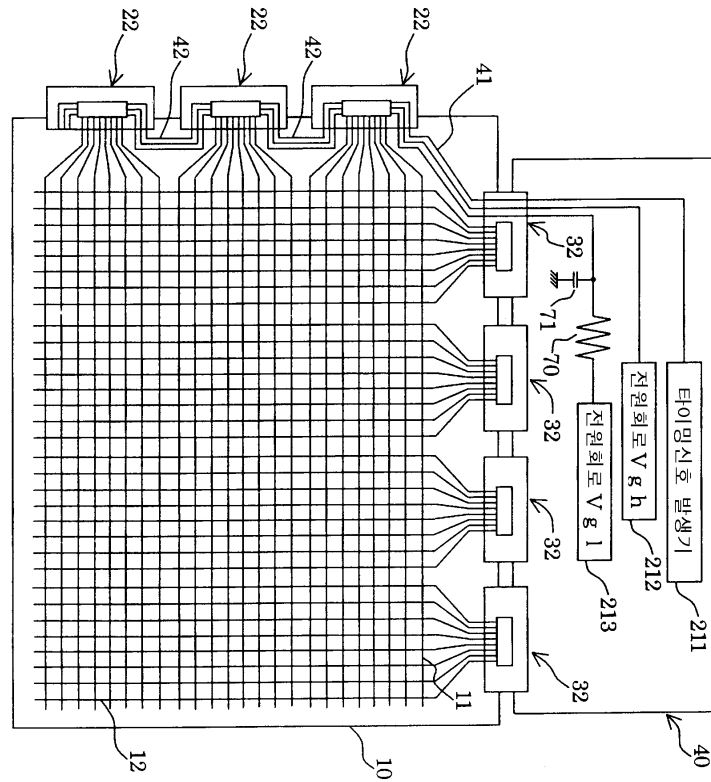

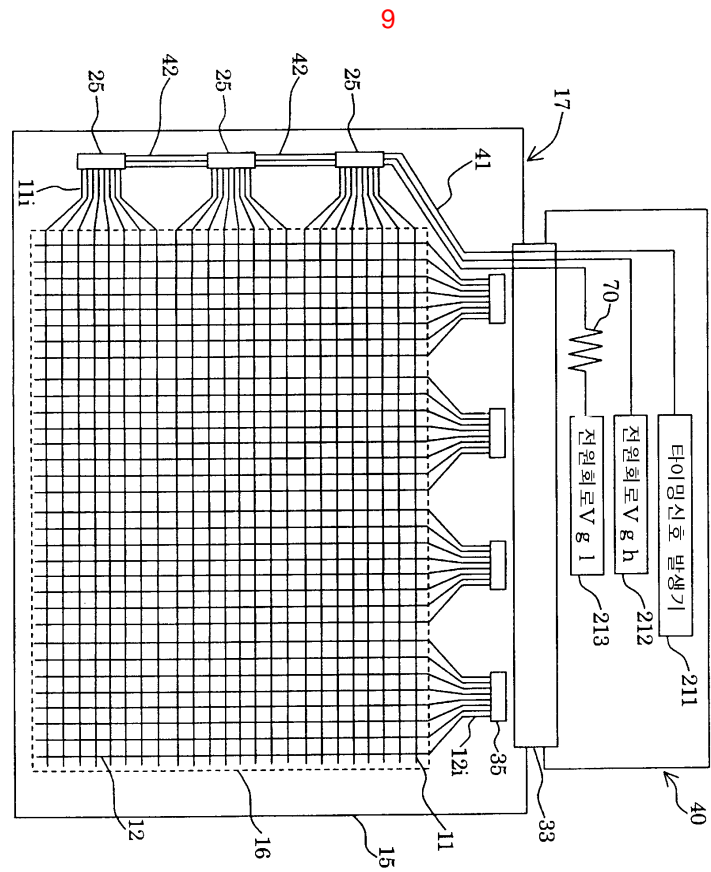
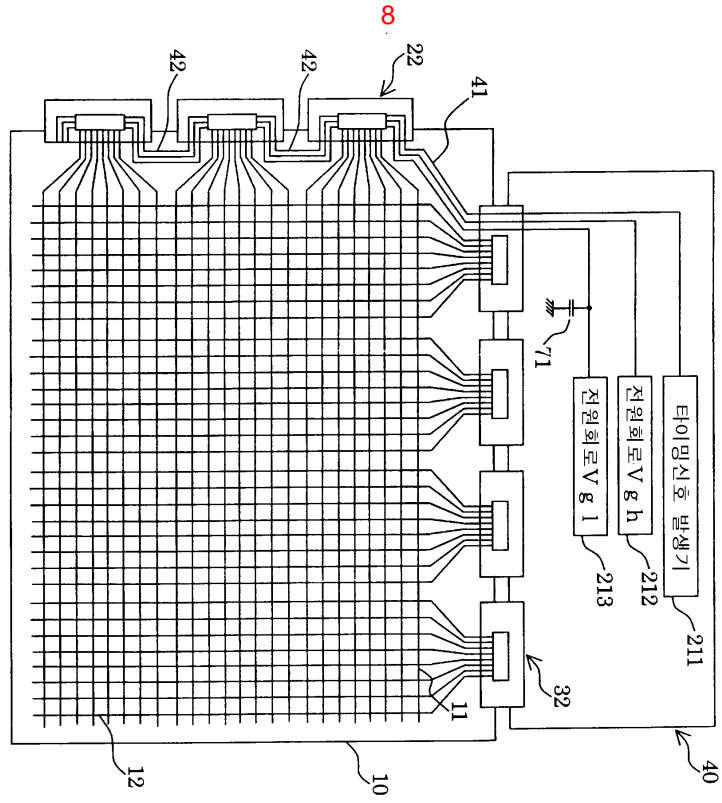

10

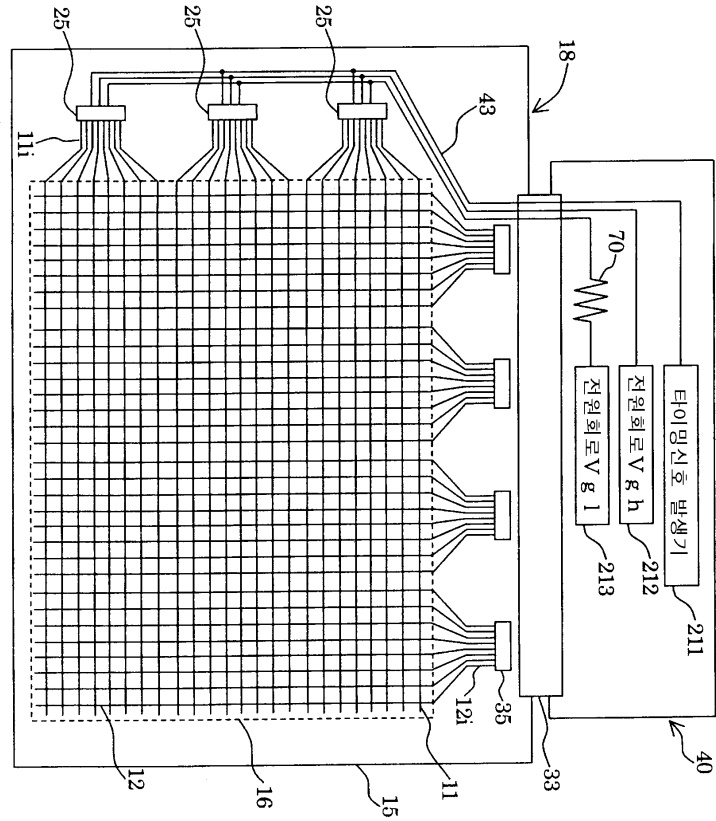

11

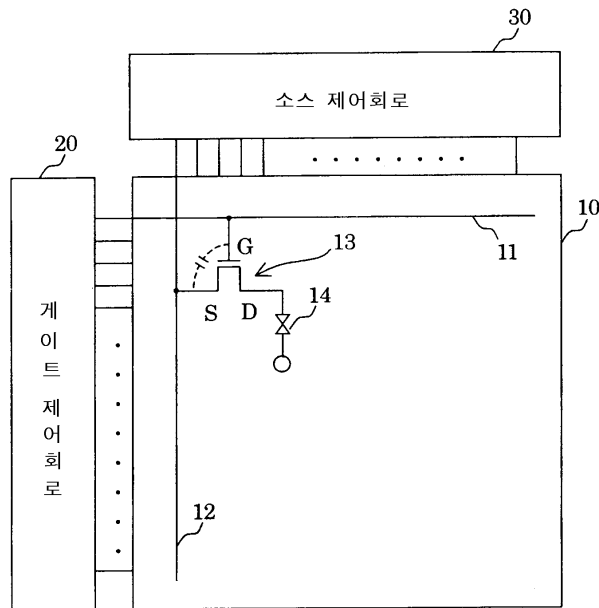

12

