

[54] LETHAL EXPANDIBLE PROJECTILE

[75] Inventor: Robert C. Mawhinney, Danville, Calif.

[73] Assignee: MB Associates, San Ramon, Calif.

[22] Filed: Aug. 19, 1971

[21] Appl. No.: 173,079

3,085,510	4/1963	Campbell.....	102/42 C
75,019	3/1868	Howard.....	102/42 C
931,723	8/1909	Bird.....	102/42 C
2,759,420	8/1956	Schultz.....	102/42 C
336,019	6/1943	Garkovenko.....	102/42 C

Primary Examiner—Robert F. Stahl
Attorney—J. King Harness et al.

[52] U.S. Cl..... 102/42 C, 102/41, 102/92.3, 102/92.7

[51] Int. Cl..... F42b 7/02

[58] Field of Search..... 102/38, 41, 42 C, 102/95, 91

[57] ABSTRACT

A high penetration, short range projectile comprised of a shot filled, deformable, flexible bag which is initially folded or rolled for insertion in a conventional cartridge case of a small firearm or the like, and adapted to be launched therefrom. Upon exit from the muzzle of the small arm, the bag radially expands under the influence of centrifugal force provided by the rifling grooves within the barrel to provide a spin stabilized trajectory characterized by a substantial energy decay in a relatively short, preselected down range distance.

[56] References Cited
UNITED STATES PATENTS

3,565,010	2/1971	Sahlmann.....	102/42 C
3,190,220	6/1965	Jones et al.....	102/42 C
3,266,421	8/1966	Comerford.....	102/42 C
3,099,958	8/1963	Daubenspeck et al.....	102/42 C

15 Claims, 11 Drawing Figures

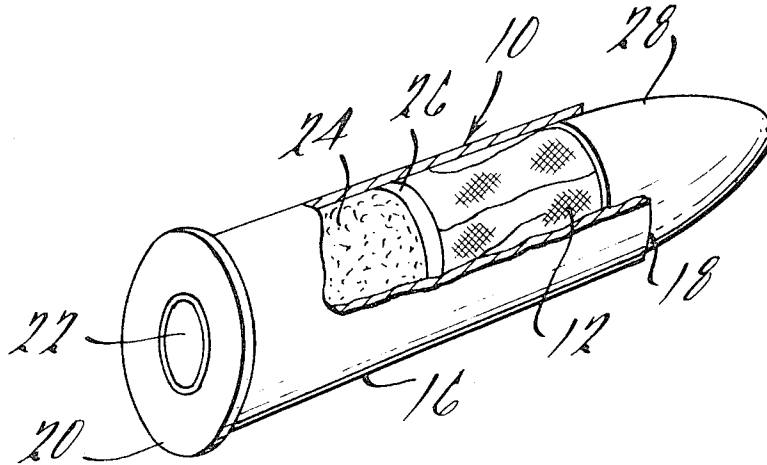

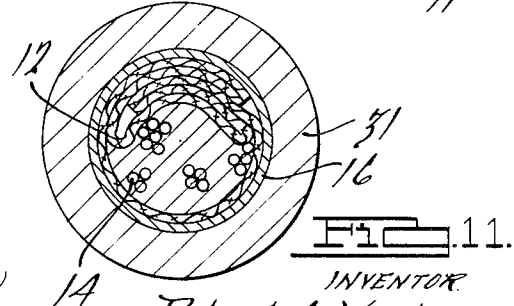
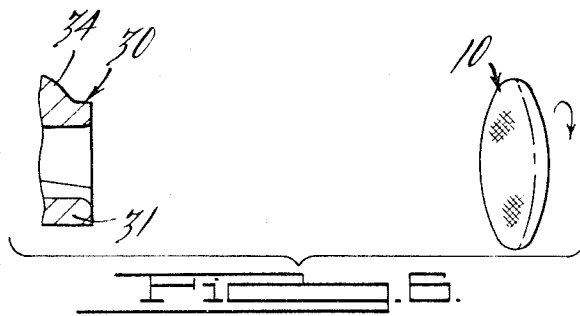
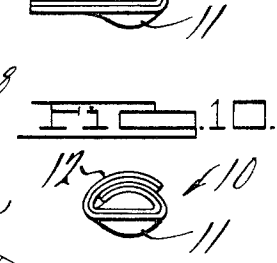
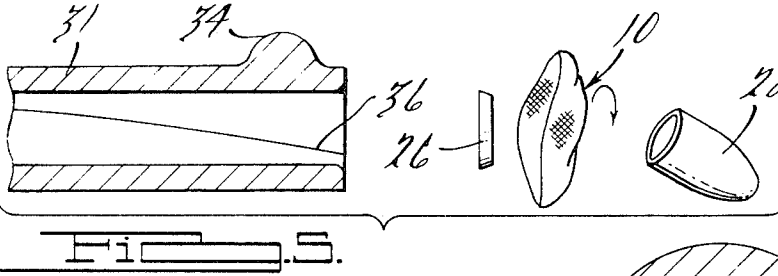
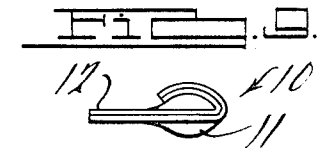
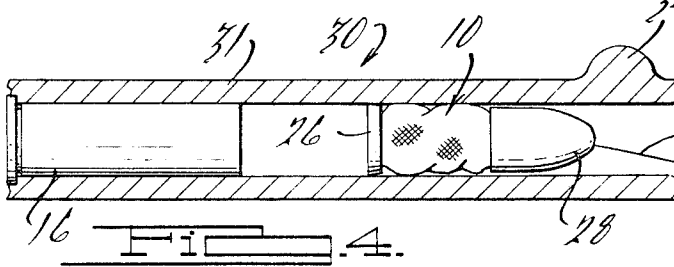
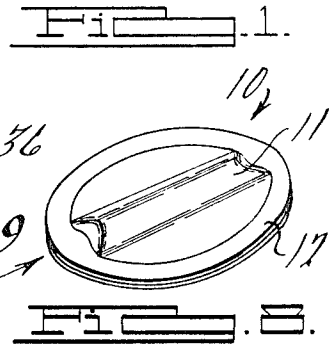
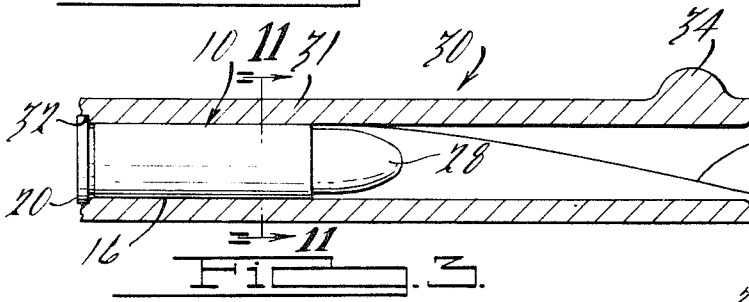
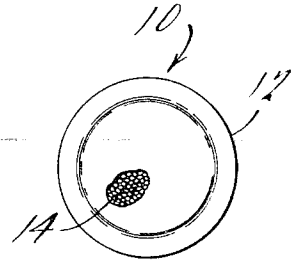
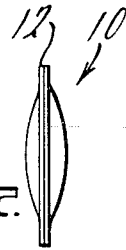
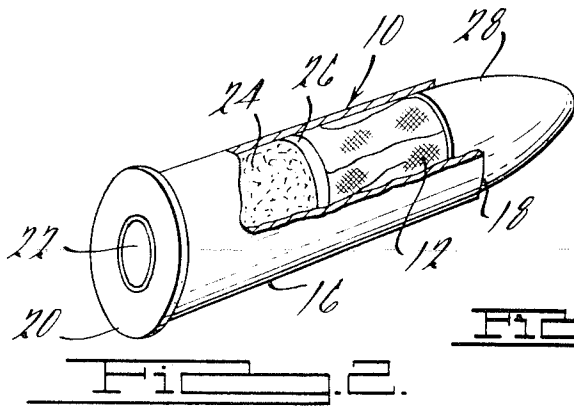

INVENTOR
 Robert C. Mawhinney
 BY
 Warner, Picky & Pierce
 ATTORNEYS

LETHAL EXPANDIBLE PROJECTILE

BACKGROUND AND SUMMARY OF THE INVENTION

This invention relates generally to the munitions art, and more particularly to a high penetration, short range projectile adapted to be fired by a small arm, such as a .38 caliber hand gun or the like.

The beneficial effect of the use of firearms in a military engagement, is substantially greater than a domestic law enforcement encounter, due to the difference in environment wherein the weapons are used. In military combat, when a member of the armed forces directs a shot at a target, i.e. an enemy soldier, there is a good chance that the primary target may be in close proximity to a number of secondary targets, such as additional enemy soldiers. Should the fired projectile miss the primary target, the possibility exists that a secondary target may be hit. Even in the event of a complete miss, a certain degree of suppression to the enemy forces is attained, and generally speaking, except for the wasteful expenditures of ammunition, every round directed against the enemy provides the firer with some beneficial effect.

The environment in which firearms are used by domestic law enforcement officials on the other hand is vastly different. This difference results from the fact that the target is typically surrounded, or in close proximity, to noncombatants (innocent bystanders) as opposed to enemy soldiers. This situation can be anticipated in all aspects of law enforcement, especially aircraft hijacking, bank robberies and fleeing felons. The domestic law enforcement situation implies that the officer must hit his target when he fires, or risk the catastrophic result of striking an innocent bystander. Unlike military combat there are no benefits to the officer if he was justified in firing, but misses his target. Even the so-called "warning shot" fired in the air has a potential range of over a mile and ultimately impacts with dangerously high energy. Thus, it is inopportune and unfortunate that law enforcement officers must rely on essentially the same ammunition which was optimized for the military, such ammunition being characterized by high lethality over an exceptionally long range.

Ideally, optimum law enforcement ammunition should deliver a bullet which would magically stop immediately after it passes by, or through, the target i. e. a bullet on a string. While this solution is not completely feasible in practice, it can be approached.

An unpowered projectile in horizontal flight has been found to be retarded by aerodynamic forces. Neglecting gravity, it can be shown that the velocity of an unpowered projectile, at any point down range, is determined by the following equation:

$$V_x = V_o e^{-x/\lambda}$$

where

V_x = velocity at some range x

V_o = initial velocity

x = distance from muzzle

λ = slowing down length = $2w/\rho AC_D$

w = projectile weight

ρ = air density

A = projectile presented area

C_D = drag coefficient

If the muzzle velocity (V_o) is assumed to be constant, the only parameter which effects the down range veloc-

ity (V_x) is a slowing down length (λ). It will be seen that if the slowing down length is large, its velocity decay is very gradual. Conversely, if the slowing down length (λ) is small, then the velocity degrades very rapidly. Examination of the factors which determine the slowing down length (λ) provides the conclusion that only projectile weight (w), projectile presented area (A), and drag coefficient (C_D) can be manipulated to vary the slowing down length (λ).

Generally speaking, the projectile presented area (A) is fixed and is nearly equal to the cross-sectional area of the bore of the launcher, leaving only the projectile weight (w) and drag coefficient (C_D) of the projectile to be varied. The subject projectile, however, allows the projectile area (A) to increase after exit from the bore of the launcher which allows flexibility in all three parameters. The above described technique is utilized to drastically alter the ballistic properties of the subject projectile in such a manner that the projectile may be made relatively safe for any selected range.

With reference now to the subject invention, a novel type of ammunition is disclosed, which can be optimized for law enforcement work. The ammunition is adaptable to have conventional high lethality, and effectiveness, at the muzzle and throughout the typical encounter range, and rapidly become non-hazardous thereafter. The inventive concept involves the use of a deformable projectile in the form of a shot filled bag which, when folded and packaged in a conventional cartridge case, requires no more volume than a standard round. However, upon launch, as the projectile is forced down the barrel, it engages the rifling grooves thereby acquiring the spin rate necessary for acquiring stability. Upon exit from the muzzle, the projectile is adapted to expand and assume a disc-like shape due to the reactional centrifugal force upon the slot particles within the bag. The enlarged disc-shape provides an increased drag coefficient (C_D) and an increased presented area (A) which afford substantial resistance to the aerodynamic forces and predictable energy decay.

It is therefore a general object of the subject invention to provide ammunition which is optimized for use in a law enforcement situation.

It is another object of the subject invention to provide ammunition useable in conjunction with conventional small arms, such as hand guns or the like.

It is still another object of the present invention to provide a deformable projectile which may be folded and packaged in a conventional cartridge case.

It is yet another object of the subject invention to provide a projectile having spin stabilized trajectory.

It is a further objective of the present invention to provide a projectile which expands and assumes a disc-like shape under the influence of centrifugal force.

It is still a further object of the present invention to provide a projectile that is stable at the conventional muzzle velocities of a small arm.

It is yet a further object of the subject invention to provide a projectile having a substantial energy decay in a selected, relatively short, down range distance.

It is still a further object of the subject invention to provide a projectile characterized by high penetration on impact over a relatively short range proximate the end of the launcher and by low penetration on impact thereafter.

It is another object of the present invention to provide a projectile which is easy to assemble, and economical to manufacture.

Other advantages of the present invention will become apparent from a consideration of the following detailed description taken in conjunction with the accompanying drawings:

BRIEF DESCRIPTION OF THE DRAWINGS

FIG. 1 is a plan view of an exemplary high penetration, short range projectile of the subject invention, having an interior portion broken away to disclose the interior content;

FIG. 2 is a perspective view of an assembled cartridge, with a partial quarter section broken away, to disclose the interior content thereof, including the projectile illustrated in FIG. 1;

FIG. 3 is a partial elevation of a small arm, with one half of the barrel portion broken away, to illustrate the orientation of the cartridge illustrated in FIG. 2;

FIG. 4 is the same partial elevation as in FIG. 3, illustrating the separation of the projectile from the cartridge case immediately after firing;

FIG. 5 is another partial elevation illustrating the relative positions of the various components after exit from the barrel of the exemplary small arm;

FIG. 6 is another partial elevation illustrating the fully expanded projectile in trajectory towards its target.

FIG. 7 is an end view of the projectile illustrated in plan in FIG. 1;

FIG. 8 is a perspective view of the projectile illustrated in FIGS. 1 and 7 illustrating the location of the shot prior to the folding step;

FIG. 9 is an end elevation of the projectile illustrated in FIG. 8, taken in the direction of the numeral 9, showing a first edge folded over the portion containing the shot;

FIG. 10 is the same end elevation as illustrated in FIG. 9 showing a second edge folded over the first edge; and

FIG. 11 is a cross-sectional elevation of the small arm and cartridge illustrated in FIG. 3 taken along the line 11-11 thereof.

DETAILED DESCRIPTION OF THE PREFERRED EMBODIMENT

With reference now to FIGS. 1 and 7 of the drawings, and in accordance with an exemplary embodiment of the subject invention, a high penetration, short range projectile is indicated generally at 10. The projectile 10 is comprised of a two-sided, relatively thin, disc-shaped bag 12 having a preselected number of grains of suitably sized shot particles 14 disposed therein. One side of the bag 12 is fabricated from a fabric, such as canvas, while the second side preferably includes a heat sealable fabric which provides an annular bond. Dimensionally for use with a .38 caliber cartridge case and by way of example, the bag 12 measures approximately one inch in diameter, but it will be appreciated that the diameter could be altered to accommodate other sized cartridge cases and also to affect the ballistic properties thereof. The size and weight of the shot particles 14 may also be varied, but again by way of example, No. 12 bird shot has been found to afford good results with a .38 caliber weapon. As previously indicated, the number of grains of shot 14 disposed within

the bag 12 will depend to some extent on the desired ballistics of the projectile 10 and the design rangeability thereof in accordance with the slowing down length (λ).

To accommodate insertion into a small arms cartridge case or the like, the flat configuration of the disc-shaped bag 12 must be initially altered. As best observed in FIG. 8, the shot particles 14 are initially displaced from random locations thereon and urged toward the center of the bag 12 by any suitable means such as by squeezing the outer annular surfaces of the bag 12. The center positioning of the shot particles 14 form a generally cylindrically shaped diametrically extending, axially enlarged center portion indicated generally at 11, which is generally oval shaped in cross section as best observed in FIG. 9 and 10. The initial folding step is illustrated in FIG. 9 wherein a first outer edge relative to the center portion 11 is folded thereover. The final step is illustrated in FIG. 10 wherein a diametrically opposite outer edge, relative to the first outer edge, is folded or rolled over the first edge to form an elongated generally cylindrical configuration shaped similar to that of a "taco." In this ultimate configuration, the bag 12 is of suitable cross section to be inserted in the open end of a cartridge case.

With reference now to FIG. 2, a cylindrically shaped cartridge case is indicated generally at 16, and may be any conventional cartridge case adaptable for use with any type of small arm as for example a .38 caliber hand gun or the like. One end of the case 16 is open, as indicated at 18, with the opposite end being closed by an annularly shaped, radially extending end wall portion 20 which projects slightly outwardly from the cartridge case 16 for purposes of being received in and seated in the receiver portion of a small arm or the like as shall hereinafter be described. The end wall 20 further includes a primer portion 22 adapted to be struck by the firing pin of a small arm as is conventional in the art. The propellant for the projectile 10 is provided by a powder charge 24 disposed within the cartridge case 16 adjacent the end wall 20, retained therein by means of a relatively thin cylindrically shaped bulkhead or gas check 26. Interposed between the gas check 26 and a relatively thin, cone shaped, end cap 28 is the suitably deformed projectile 10. Preferably the end cap 28 and gas check 26 are formed from a relatively light weight plastic so as to contribute negligible weight to the assembled cartridge for purposes to be subsequently explained. Additionally, it will be noted that the projectile 10 in its nested position is easily packaged in the conventional cartridge case 16, with the assembled case 16 requiring no more volume than a standard round.

FIGS. 3 and 11 of the drawings illustrate an exemplary small arm 30 which includes a barrel portion 31 having a front iron sight at 34 and internal rifling grooves designated by 36. The left end of the barrel 30 is suitably counterbored as indicated at 32, to receive the radially enlarged end wall 20 of the cartridge case 16. The small arm 30 may be any hand operated or shoulder supported weapon, and for purposes of illustration will be considered a .38 caliber hand gun having internal rifling grooves 36. The cartridge 16 is indicated in the pre-firing position disposed in the receiver portion 32, the small arm 30 having a firing pin (not shown) suitably located and adapted to strike the primer 22. Upon release of the firing pin by any suitable means, such as pull of a trigger, the firing pin will

strike the primer 22 thereby detonating the propellant or powder charge 24. Since the cartridge case 16 is restrained by the engagement of the counterbore or receiver 32 and the enlarged end wall 32, the detonation force of the propellant launches the gas check 26, the projectile 10, and the end cap 28 towards the muzzle end of the barrel 30. By means of the internal rifling grooves 36 within the barrel 30, it will be noted that rotation is imparted to the projectile 10 as well as longitudinal thrust.

FIG. 4 indicates the relation of the elements immediately after detonation of the propellant charge 24, wherein the gas check 26, projectile 10, and end cap 28 are disunited from the case 16 and FIG. 5 indicates the relation of the components upon exit from the barrel 30. The end cap 28 and gas check 26 have appreciably less mass than the projectile 10 and therefore due to aerodynamic forces, separate from the trajectory line of the projectile 10. Due to rotation of the projectile 10 provided by the rifling grooves 36, the centrifugal force imposed on the shot particles 14 to radially displace from the center portion 11 and cause the projectile 10 to radially expand, the projectile 10 now assuming a substantially disc shape of enlarged transverse cross section and dimensionally relatively thin with respect to the axis of trajectory.

FIG. 6 illustrates the projectile 10 in its fully radially expanded shape proceeding in its trajectory in a manner calculated to provide substantial energy decay in a relatively short preselected down range distance, and further providing substantial impact energy against a target between the muzzle of the small arm 30 and the preselected distance.

It will be noted that the projectile 10 is adapted to have predictable ballistic characteristics, such characteristics being predictable by the design of the presented cross-sectional area, the basic configuration of the projectile in flight, and the number of grains of shot disposed in the bag 12 which provides the mass to the projectile. Thus, the ballistic characteristics of the projectile 10 are such that the impact energy may be effectively dissipated in any desired distance. It will further be appreciated that the subject invention provides a novel type of ammunition which can be optimized for use in the law enforcement environment. The projectile can have conventional high lethality and effectiveness proximate the muzzle and throughout the typical encounter range, and ultimately become rapidly non-hazardous thereafter. It will be further noted that the projectile 10 will be completely spin stabilized in flight due to the reaction of the imposed centrifugal force acting upon the shot 14, the centrifugal force and spin rate being initiated by the rifling grooves 36.

While it will be appreciated that the embodiments illustrated herein are calculated to fulfill the objects above stated, it will be appreciated that the subject invention is susceptible to modification, variation and change without departing from the scope of the invention.

What is claimed is:

1. In combination with a cartridge case of a small arm or the like; the cartridge case having an open end and a slightly enlarged end wall relative to the outer surface of the case closing an opposite end, a primer located in the enlarged end wall, a propellant charge located in the case proximate the primer; a projectile comprising:

a deformable container and a preselected number of particles located therein, said container including at least one circularly shaped member formed on a diameter which is substantially larger than the diameter of the cartridge case, said member at least partially defining an outer peripheral surface of said container and being rolled on a diameter approximating the inside diameter of the cartridge case whereby to accommodate insertion of said projectile within said case.

2. The combination, as recited in claim 1, further comprising:

a gas check located in the cartridge case between the propellant charge and said projectile; and cap means for closing the open end of the cartridge case after insertion of said projectile.

3. The combination, as recited in claim 1, wherein said particles are grains of shot, and wherein the range of said projectile is a function of the number of grains of shot.

4. The combination, as recited in claim 1, wherein said container is a two-sided bag, said bag being fabricated from a first side of canvas and a second side from a heat sensitive material, said first side being bonded to said second side.

5. The combination, as recited in claim 2, wherein said cap means is press fitted into the open end of the cartridge case, and wherein said cap means is fabricated from a light weight plastic material.

6. A cartridge for a small hand gun or the like including a case having a primer and charge located in one end and a projectile located in an opposite end, said projectile comprising:

an outer wall formed from a disc shaped deformable material, said wall being rolled to define a cross-section in substantial conformance to the cross-section of said case;

a plurality of particles located along and adjacent to a common diameter of said wall; and means for enclosing said particles relative to a surface of said wall.

7. The cartridge, as recited in claim 6, wherein said wall includes a marginal edge in overlapped relationship relative to an opposite marginal edge thereof.

8. The cartridge, as recited in claim 6, wherein said means includes an inner wall of identical shape to said outer wall and wherein said inner and outer walls are connected together along outer circumferential edges.

9. A cartridge for a small hand gun or the like including a case having a primer and charge supported therein and a projectile slidably located in an opposite end, said projectile comprising:

particle means for providing preselected mass to said projectile; and

deformable means for providing an enclosure for said particle means, said deformable means including first and second circularly shaped wall members each having an outside diameter greater than the diameter of said case, with said diameter defining the longitudinal length of said projectile, each of said wall members including oppositely spaced lateral sides which are folded over the define a cross-section of said projectile substantially equal to the cross-section of said case, and with said particle means being located along a common diameter of said wall members.

10. The cartridge, as recited in claim 9, wherein said common diameter is parallel to the longitudinal axis of said case.

11. The cartridge, as recited in claim 9, wherein said wall members are bonded together along an outer peripheral edge thereof.

12. A cartridge including a cylindrically shaped case and a projectile located therein, said projectile comprising:

an outer wall formed from a flexible material and rolled about the inner peripheral surface of said case;

an inner wall connected to said outer wall and rolled about the inner peripheral surface of said outer wall; and

5

10

15

20

25

30

35

40

45

50

55

60

65

a plurality of particles located between said inner and outer walls.

13. The cartridge, as recited in claim 12, wherein each of said outer and inner walls are disc shaped and wherein each includes oppositely spaced overlapped marginal edges.

14. The cartridge, as recited in claim 13, wherein said particles are radially spaced on opposite sides in said case relative to said overlapped edges and eccentrically located relative to the longitudinal axis of said case.

15. The cartridge, as recited in claim 13, wherein the cross-sectional perimeter of said outer wall and the diameter thereof are equal.

* * * * *

UNITED STATES PATENT OFFICE
CERTIFICATE OF CORRECTION

Patent No. 3,762,329 Dated October 2, 1973

Inventor(s) Robert C. Mawhinney

It is certified that error appears in the above-identified patent and that said Letters Patent are hereby corrected as shown below:

Column 1, line 14, "solider" should be --soldier--.
Column 6, line 64, "the" should be --to--.

Signed and sealed this 24th day of September 1974.

(SEAL)
Attest:

McCOY M. GIBSON JR.
Attesting Officer

C. MARSHALL DANN
Commissioner of Patents

UNITED STATES PATENT OFFICE
CERTIFICATE OF CORRECTION

Patent No. 3,762,329 Dated October 2, 1973

Inventor(s) Robert C. Mawhinney

It is certified that error appears in the above-identified patent and that said Letters Patent are hereby corrected as shown below:

Column 1, line 14, "solider" should be --soldier--.
Column 6, line 64, "the" should be --to--.

Signed and sealed this 24th day of September 1974.

(SEAL)
Attest:

McCOY M. GIBSON JR.
Attesting Officer

C. MARSHALL DANN
Commissioner of Patents