



(12) **United States Design Patent**
Fries et al.

(10) **Patent No.:** **US D784,931 S**
(45) **Date of Patent:** **** Apr. 25, 2017**

(54) **SENSOR CONNECTOR CABLE**

(71) Applicant: **COVIDIEN LP**, Mansfield, MA (US)

(72) Inventors: **Timothy W. Fries**, Louisville, CO (US); **David P. Besko**, Thornton, CO (US)

(73) Assignee: **Covidien LP**, Mansfield, MA (US)

(**) Term: **15 Years**

(21) Appl. No.: **29/539,756**

(22) Filed: **Sep. 17, 2015**

(51) **LOC (10) Cl.** **13-03**

(52) **U.S. Cl.** **D13/153**

(58) **Field of Classification Search**
USPC ... D13/153, 133, 139.7, 146, 147, 154, 184, D13/199; D14/299, 433, 435.1; 439/350, 439/447, 459, 502, 582, 607.4, 607.53, 439/620, 660, 677, 680, 681, 682, 687, 439/694, 696, 844, 854, 855
CPC H01R 24/00; H01R 24/38; H01R 13/025; H01R 13/62; H01R 13/6205; H01R 12/72; H01B 7/04; H01B 13/06; H04N 21/23424; G02B 6/3825; G02B 6/3879; G02B 6/3893; G06F 13/4068
See application file for complete search history.

(56) **References Cited**

U.S. PATENT DOCUMENTS

4,964,408 A 10/1990 Hink et al.
5,069,213 A 12/1991 Polczynski
(Continued)

FOREIGN PATENT DOCUMENTS

EP 1945099 7/2008
JP 6016774 3/1994
(Continued)

OTHER PUBLICATIONS

INVOS Cerebral/Somatic Oximeter, Reflects Site-Specific Tissue Perfusion Noninvasively, 11-PM-0258 mn21410; 883-11-PM-0258BRC_INVOSNeonatalBrochure-singles-1320864559 (2010).
(Continued)

Primary Examiner — Wan Laymon
Assistant Examiner — Mark Booker
(74) *Attorney, Agent, or Firm* — Fletcher Yoder PC

(57) **CLAIM**

We claim the ornamental design for a sensor connector cable, as shown and described.

DESCRIPTION

FIG. 1 is a perspective view of the sensor connector cable of the present invention;
FIG. 2 is a top view of the sensor connector cable of FIG. 1
FIG. 3 is a bottom view of the sensor connector cable of FIG. 1
FIG. 4 is a right side view of the sensor connector cable of FIG. 1
FIG. 5 is a left side view of the sensor connector cable of FIG. 1
FIG. 6 is a front view of the sensor connector cable of FIG. 1
FIG. 7 is a rear view of the sensor connector cable of FIG. 1; and,
FIG. 8 is a perspective view of an alternate embodiment of the sensor connector cable.
Any subject matter shown in broken lines in the drawings constitutes the environment only and forms no part of the protection sought.
The broken away symbols in the drawings indicate that any portion of the article beyond what is shown forms no part of the claimed design.

1 Claim, 5 Drawing Sheets

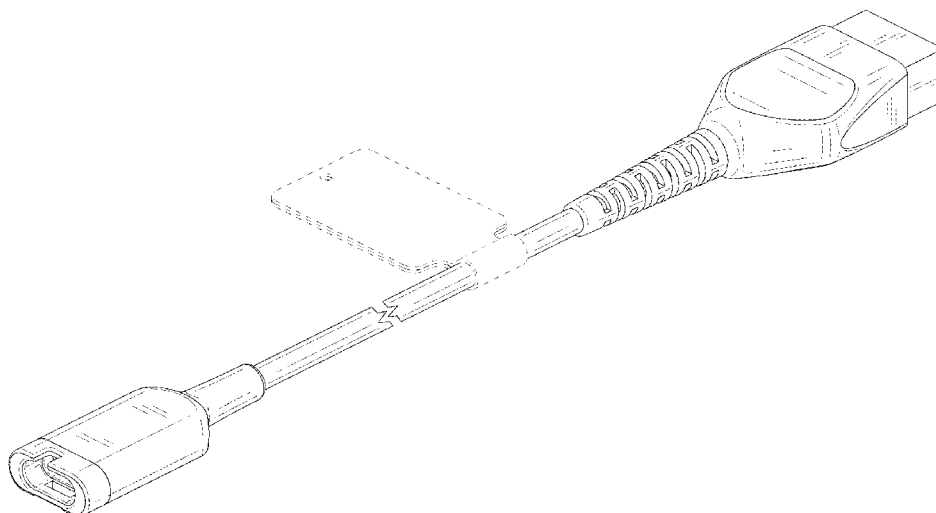

(56)

References Cited

U.S. PATENT DOCUMENTS

5,154,175 A 10/1992 Gunther
 5,228,440 A 7/1993 Chung et al.
 5,249,576 A 10/1993 Goldberger et al.
 5,287,853 A 2/1994 Vester et al.
 5,343,869 A 9/1994 Pross et al.
 5,387,122 A 2/1995 Goldberger et al.
 5,425,362 A 6/1995 Siker et al.
 5,491,299 A 2/1996 Naylor et al.
 5,645,440 A 7/1997 Tobler et al.
 5,660,567 A 8/1997 Nierlich et al.
 5,743,260 A 4/1998 Chung et al.
 5,790,729 A 8/1998 Pologe et al.
 5,851,178 A 12/1998 Aronow
 5,890,929 A 4/1999 Mills et al.
 5,934,925 A 8/1999 Tobler et al.
 5,961,452 A 10/1999 Chung et al.
 5,997,343 A 12/1999 Mills et al.
 6,014,576 A 1/2000 Raley
 6,026,312 A 2/2000 Shemwell et al.
 6,112,107 A 8/2000 Hannula
 6,152,754 A 11/2000 Gerhardt et al.
 6,165,005 A 12/2000 Mills et al.
 6,253,097 B1 6/2001 Aronow et al.
 6,280,213 B1 8/2001 Tobler et al.
 D450,041 S * 11/2001 Nakashima D13/153
 6,370,409 B1 4/2002 Chung et al.
 6,541,756 B2 4/2003 Schulz et al.
 6,678,543 B2 1/2004 Diab et al.
 6,850,788 B2 2/2005 Al-Ali
 7,117,590 B2 10/2006 Koenig et al.
 7,132,641 B2 11/2006 Schulz et al.
 7,210,959 B1 5/2007 Teves
 7,225,006 B2 5/2007 Al-Ali et al.
 7,248,910 B2 7/2007 Li et al.
 7,371,981 B2 5/2008 Abdul-Hafiz
 7,377,794 B2 5/2008 Al-Ali et al.
 D576,102 S * 9/2008 Zenri D13/147
 7,427,165 B2 9/2008 Benaron et al.
 D636,337 S * 4/2011 Smith D13/147

D692,390 S * 10/2013 Smith D13/133
 D706,248 S * 6/2014 Myung D14/240
 D707,180 S * 6/2014 Yi D13/147
 D716,235 S * 10/2014 Tien D13/147
 D743,965 S * 11/2015 Laffon de Mazieres D13/154
 D747,273 S * 1/2016 Langhammer D13/147
 2002/0103423 A1 8/2002 Chin et al.
 2003/0135099 A1 7/2003 Al-Ali
 2003/0162414 A1 8/2003 Schulz et al.
 2004/0267103 A1 12/2004 Li et al.
 2005/0113704 A1 5/2005 Lawson et al.
 2006/0211932 A1 9/2006 Al-Ali et al.
 2006/0241363 A1 10/2006 Al-Ali et al.
 2007/0123783 A1 5/2007 Chang
 2008/0064940 A1 3/2008 Raridan
 2008/0071153 A1 3/2008 Al-Ali et al.
 2008/0076980 A1 3/2008 Hoarau
 2008/0076995 A1 3/2008 Hoarau
 2008/0076996 A1 3/2008 Hoarau
 2008/0081954 A1 4/2008 Meyer et al.
 2008/0220633 A1 9/2008 Al-Ali et al.
 2008/0255435 A1 10/2008 Al-Ali et al.
 2008/0316488 A1 12/2008 Mao et al.

FOREIGN PATENT DOCUMENTS

JP 24329406 11/2004
 JP 25052385 3/2005
 JP 25110816 4/2005
 JP 26061566 3/2006
 JP 27117641 5/2007
 JP 27167183 7/2007
 JP 27167184 7/2007
 JP 27190122 8/2007

OTHER PUBLICATIONS

A monitor designed to help treat a range of complex patients;
 12673-DesignedtoTreat-1402592390 (2012 INVOS brochure).

* cited by examiner

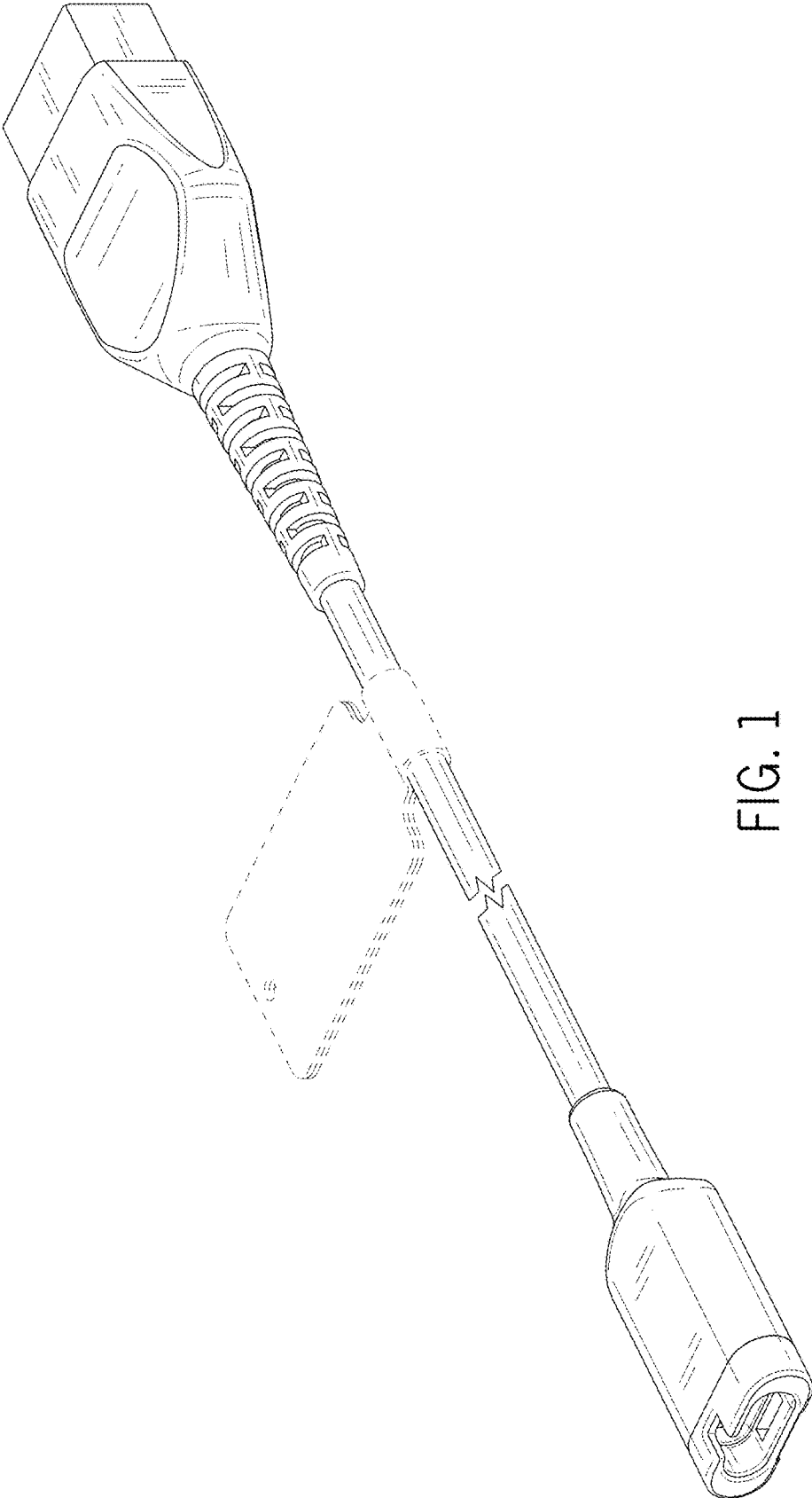

FIG. 1

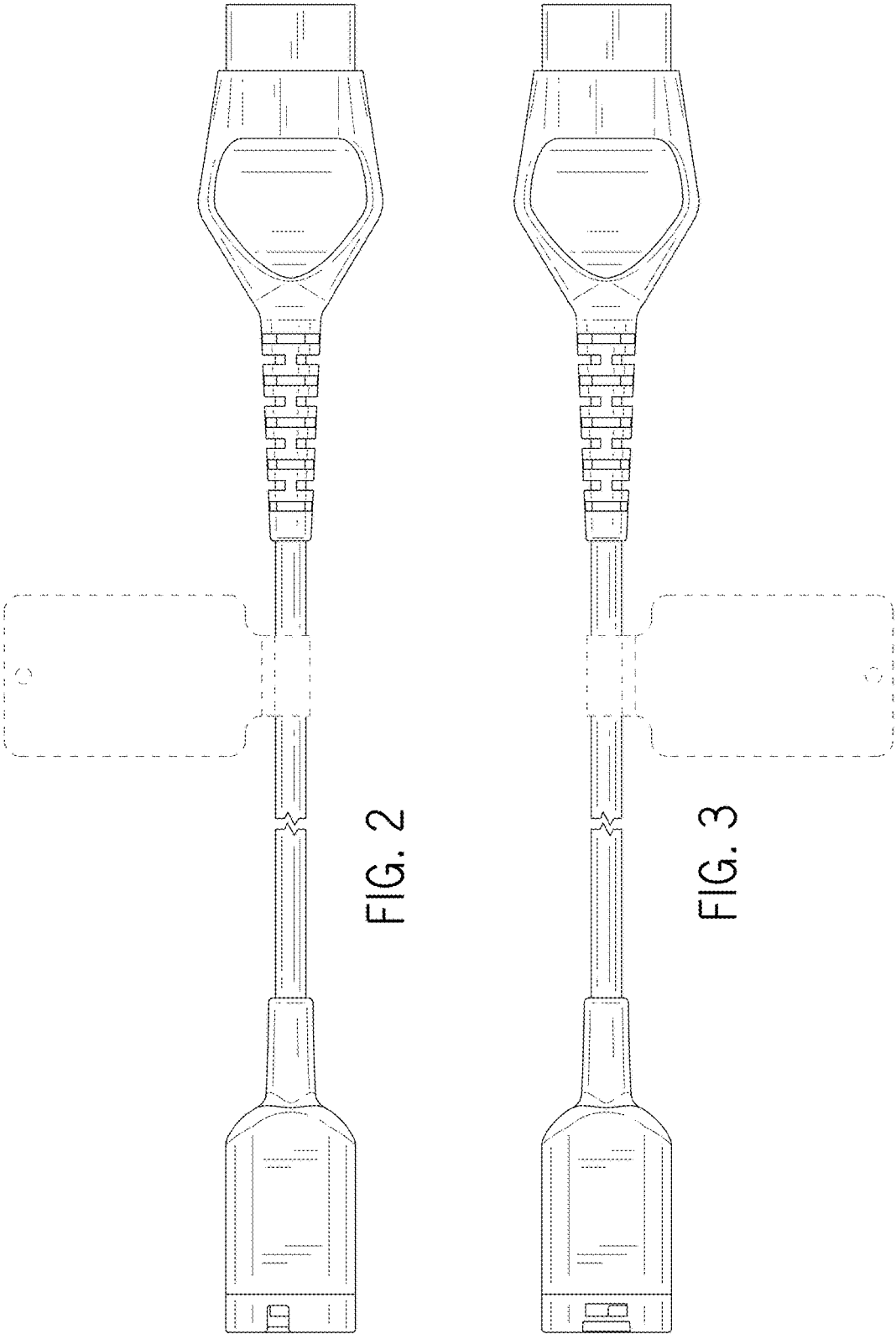

FIG. 2

FIG. 3



FIG. 4

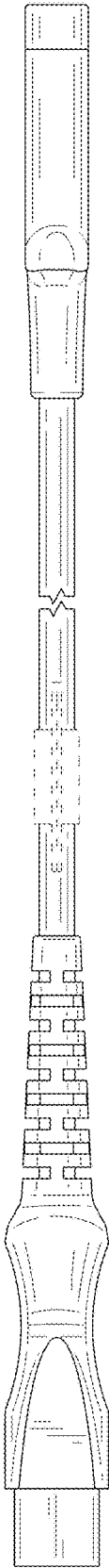

FIG. 5

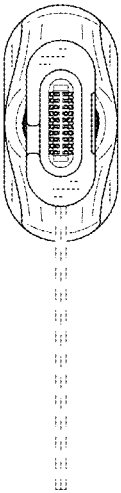

FIG. 6

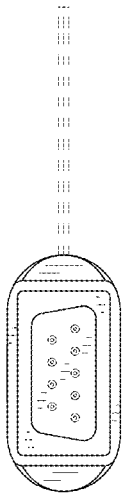

FIG. 7

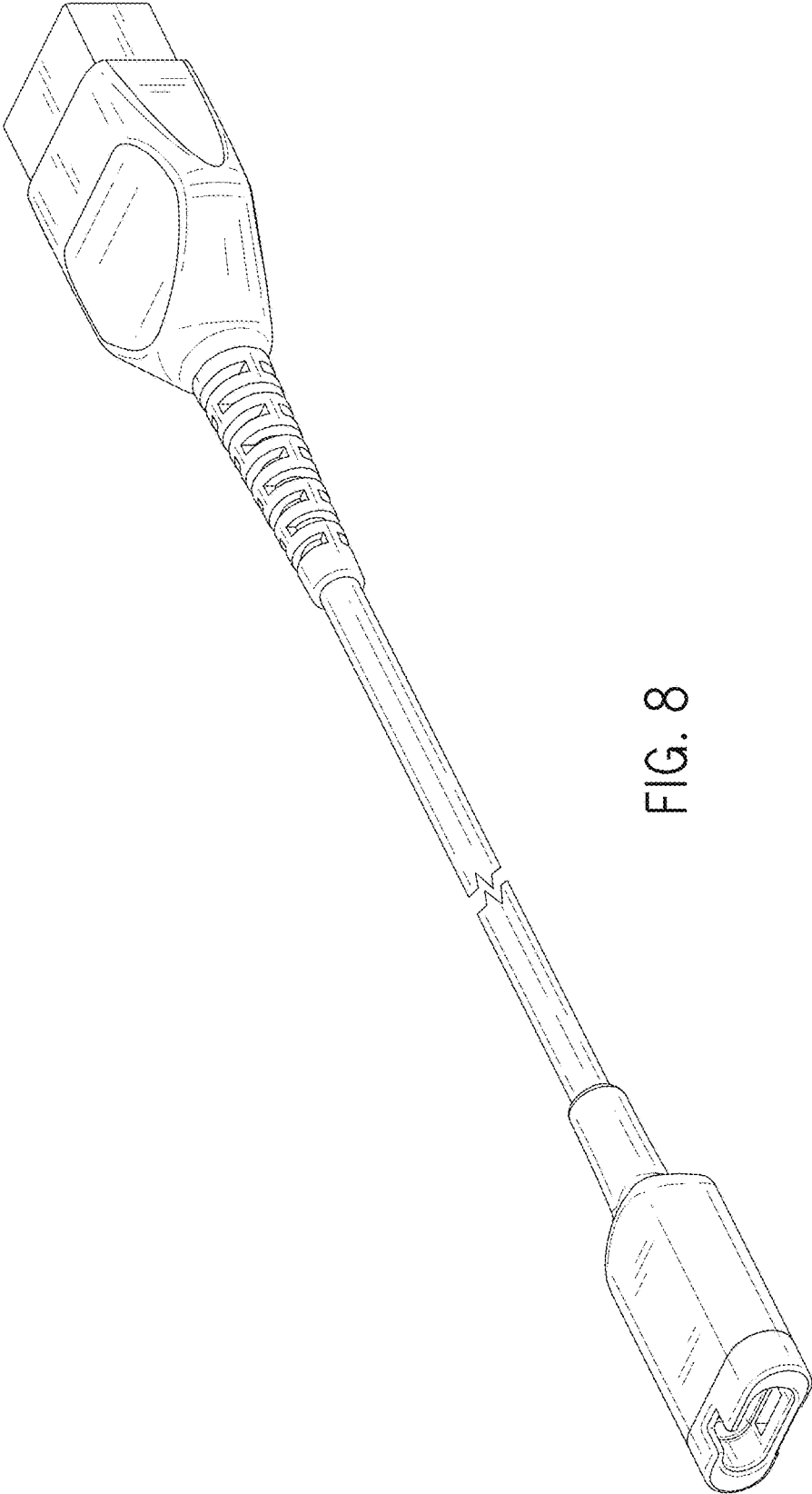

FIG. 8