

[54] MEANS FOR PROVIDING AN INFORMATION SIGNAL OF SAMPLE INTRODUCTION IN APPARATUS FOR CHEMICAL ANALYSIS

[75] Inventors: Kenichi Kishimoto, Osaka; Hiroshi Miyauchi, Kyoto; Yasuhiko Inagaki, Kyoto; Joji Fujimoto, Kyoto, all of Japan

[73] Assignee: Yanagimoto Seisakusho Co., Ltd., Kyoto, Japan

[22] Filed: Feb. 23, 1972

[21] Appl. No.: 228,581

Related U.S. Application Data

[63] Continuation-in-part of Ser. No. 161,447, July 12, 1971, abandoned.

[30] Foreign Application Priority Data

Feb. 24, 1971 Japan..... 46-11624  
 July 15, 1970 Japan..... 45-61881  
 Mar. 31, 1971 Japan..... 46-23853

[52] U.S. Cl. .... 23/253 R, 23/232 C, 23/254 R, 23/259, 73/422 GC, 141/329

[51] Int. Cl. .... G01n 1/14, B65b 1/04

[58] Field of Search..... 23/232 C, 253, 254, 230, 23/259; 73/425.6, 23.1, 422 GC; 141/329

[56] References Cited

UNITED STATES PATENTS

3,111,390 11/1963 Taylor..... 23/232 C

3,322,500	5/1967	Sternberg.....	23/253 R
3,374,660	3/1968	McKinney et al.....	23/232 C
3,535,084	10/1970	Izawa et al.....	23/253 X
3,559,703	2/1971	Maul.....	73/422 GC
3,581,573	6/1971	Purcell et al.....	73/422 GC

Primary Examiner—R. E. Serwin  
 Attorney, Agent, or Firm—Morgan, Finnegan, Durham & Pine

[57] ABSTRACT

In apparatus for chemical analysis in which a sample to be analyzed is injected to a sample introduction section of said apparatus by means of a syringe having an injection needle which pierces an elastic plug covering a sample introduction opening formed in said sample introduction section, the improved means for providing an information signal of sample introduction comprises a movable member engageable with said syringe when a sample is injected by said syringe to said sample introduction section, a stationary member cooperating with said movable member, an electrical switch which is closed and opened in response to the relative movement between said movable member and said stationary member, and an electrical circuit including said electrical switch and means for providing an electrical signal for the sample introduction so that the sample introduction time is automatically detected and the information signal of sample introduction is transmitted to a recorder or computer.

12 Claims, 6 Drawing Figures

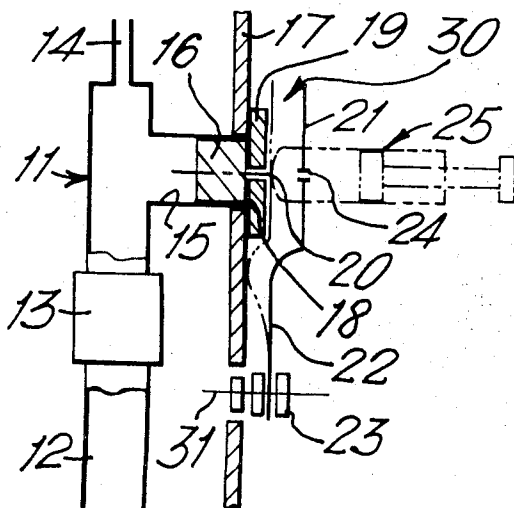

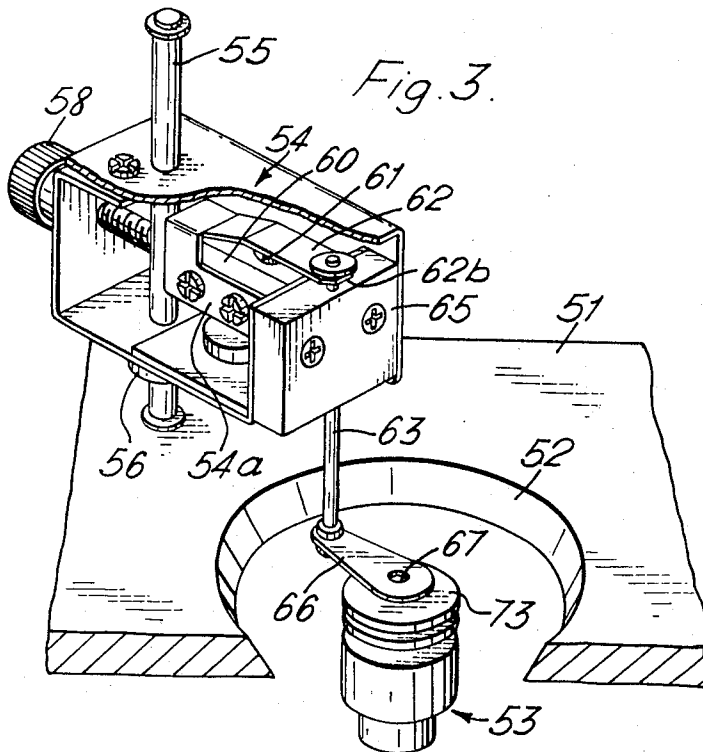
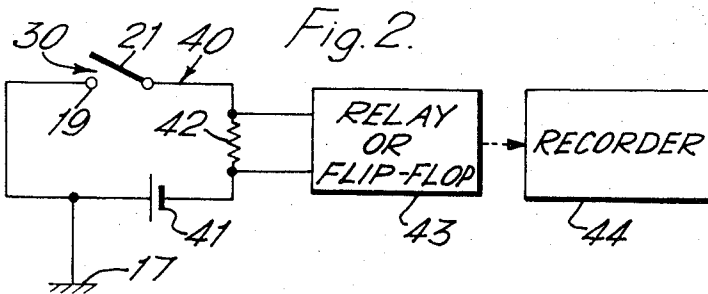
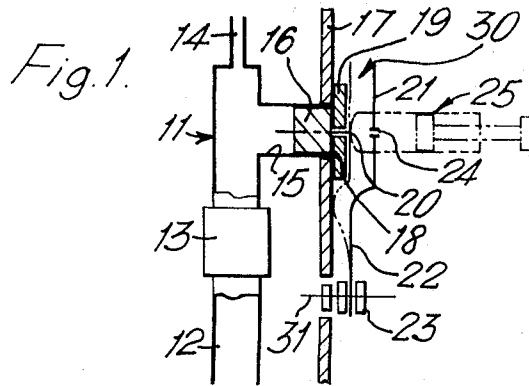

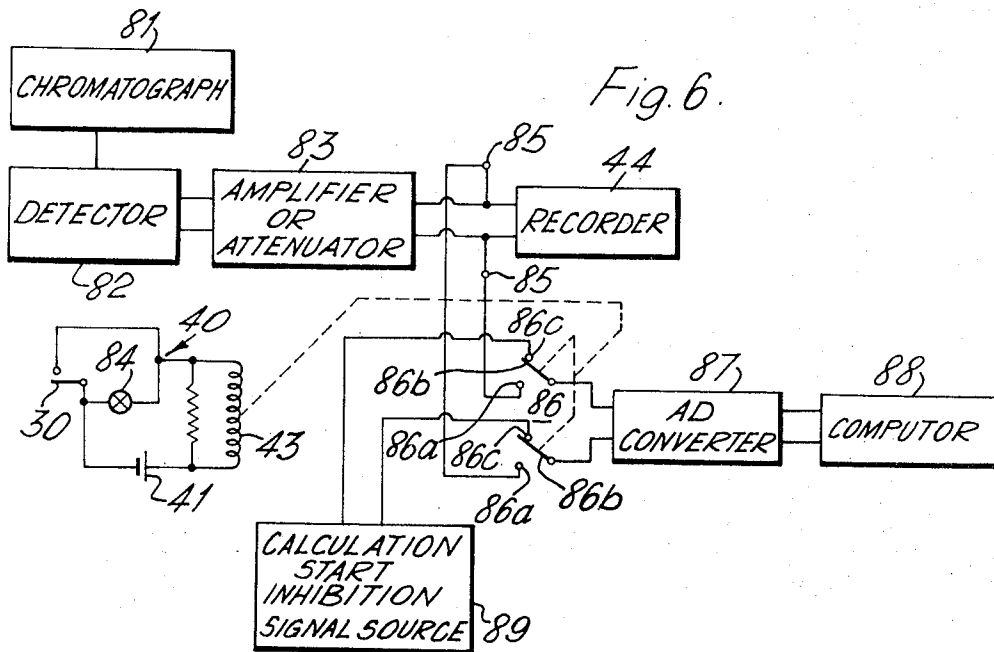
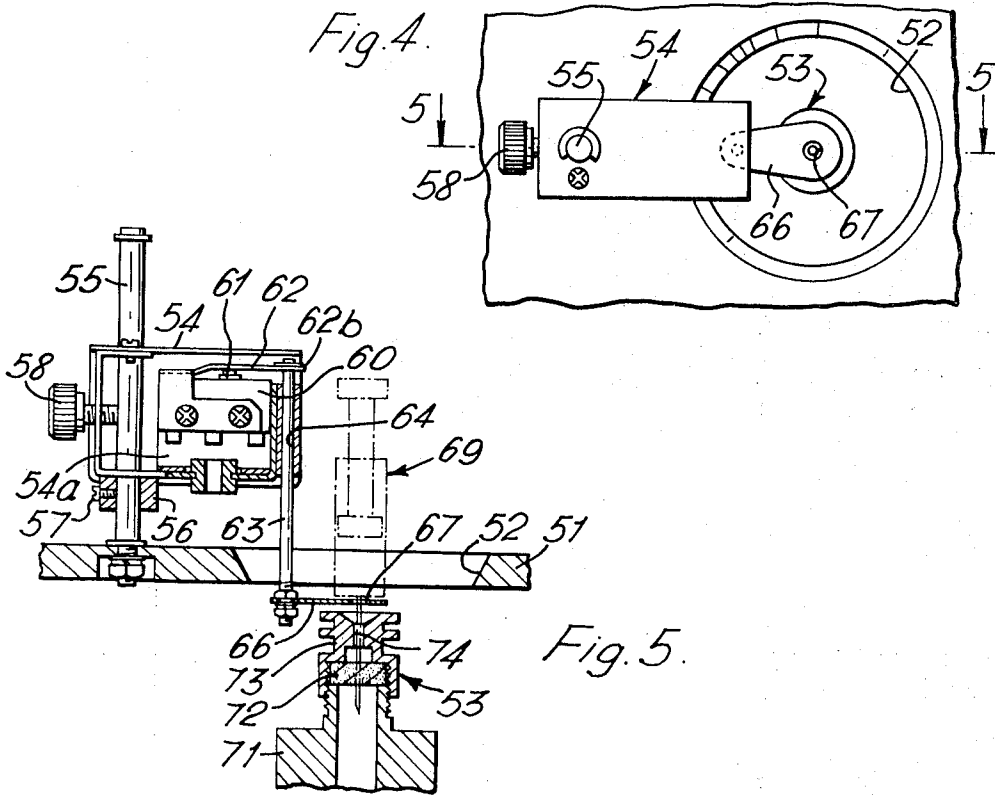

# MEANS FOR PROVIDING AN INFORMATION SIGNAL OF SAMPLE INTRODUCTION IN APPARATUS FOR CHEMICAL ANALYSIS

## CROSS-REFERENCE TO RELATED APPLICATION

This application is a continuation-in-part of co-pending Application Ser. No. 161,447 filed July 12, 1971, now abandoned, for APPARATUS FOR CHEMICAL ANALYSIS.

## BACKGROUND OF THE INVENTION

This invention relates to improved means for producing an information signal of sample introduction in apparatus for chemical analysis in which a sample to be analyzed is injected to a sample introduction section of said apparatus by means of an injector or syringe having an injection needle which pierces an elastic cap or plug covering a sample introduction opening formed in said sample introduction section.

In various sample analyzing systems, e.g. in vapor phase or liquid phase chromatographs, what is directly obtained as a result of analysis is a chromatogram having at least one peak, usually a plurality of peaks. The time needed from the time when a sample is introduced into the analyzing system until a chromatogram peak is emerged is called the "retention time." This retention time is an important value for the qualitative analysis of the sample. Accordingly, the sample introduction time must be exactly recorded in a recorder of such apparatus for chemical analysis. In the case of processing the analytic data with a computer, in order to accurately measure the retention time it is required that the start of introduction of a sample into the analyzing column of the chromatograph be in exact synchronism with the start of memorization or calculation operation in a computer.

In vapor phase chromatographs a vaporizable sample liquid to be analyzed is usually introduced into a sample introduction section at the end of analyzing column by injecting it into the sample introduction section with use of a usual syringe or microsyringe having an injection needle which pierces a sealing cap or plug, made of elastic material such as heat-resistant silicon rubber, which covers a sample introduction opening formed in the sample introduction section of the column.

The primary object of the invention is to provide new and improved means for producing an information signal of sample introduction in apparatus for chemical analysis so that the time of sample introduction is automatically detected the detected signal is transmitted to a recorder or computer connected to said apparatus for chemical analysis.

Another object of the invention is to provide an improved vapor phase chromatograph in which the retention time of each of the sample constituent can be accurately determined by a recorder or computer connected to the vapor phase chromatograph.

A further object of the invention is to provide improved means for producing an information signal of sample introduction in a vapor phase chromatograph in which the time of injection of a vaporizable sample liquid to an analyzing column by a syringe is automatically detected and an electrical signal for informing the time of sample introduction is produced and transmitted to a recorder or computer.

## SUMMARY OF THE INVENTION

In apparatus for chemical analysis to which the invention is applied, a sample to be analyzed is injected to a sample introduction section by means of a syringe having an injection needle which pierces an elastic cap or plug sealingly covering a sample introduction opening formed in said sample introduction section. Improved means for producing an information signal of the sample introduction according to the invention comprises a movable member engageable with said syringe when a sample is injected by said syringe to said sample introduction section, a stationary member cooperating with said movable member, an electrical switch which is closed and opened in response to the relative movement between said movable member and said stationary member, and an electric circuit including said electrical switch and means for producing an electrical signal for the sample introduction information. The electrical switch may comprise an electrical contact on said movable member and a cooperating electrical contact on said stationary member, said electrical contacts becoming in contact with each other when said movable member is moved toward said stationary member during the sample injecting operation.

In another preferred embodiment the electrical switch is a microswitch which is operable by movement of said movable member.

Said movable member may be normally supported in a position spaced from said elastic cap or plug and has a central opening in alignment with said elastic cap so that said injection needle may pass through said central opening and said syringe may engage with the portion of said movable member defining said central opening.

The electrical signal for sample introduction information produced is transmitted to a recorder having a chromatograph or a computer for processing analytical data from a detector of said apparatus for chemical analysis.

## BRIEF DESCRIPTION OF THE DRAWINGS

FIG. 1 is a schematic sectional view showing means for providing an information signal of sample introduction in a vapor phase chromatograph embodying the present invention;

FIG. 2 is an electrical circuit diagram including means for producing an information signal of sample introduction in connection with the apparatus illustrated in FIG. 1;

FIG. 3 is a perspective view of another embodiment of the invention in which a microswitch is used;

FIG. 4 is a top plan view of the device as shown in FIG. 3;

FIG. 5 is a cross sectional view taken along the lines 5-5 of FIG. 4; and

FIG. 6 is a block diagram of apparatus for chemical analysis and data processing system including means for producing an information signal of sample introduction according to the invention.

## DESCRIPTION OF THE PREFERRED EMBODIMENTS

Referring now to the drawings, the sample introduction section of a vapor phase chromatograph having improved means for producing an information signal of

sample introduction embodying the present invention is illustrated in FIG. 1. The sample introduction section 11 is connected to one end of a vapor phase chromatographic column 12 by a connector 13 provided with a carrier gas inlet opening 14 and a sample introduction opening 15. The sample introduction opening 15 is sealingly covered by an elastic plug 16 which is made of heat-resistant silicon rubber. The sample introduction section 11 is supported at its portion defining said sample introduction opening 15 by a panel 17. The reference numeral 18 indicates an opening formed in the panel 17 for supporting that portion defining the sample introduction opening 15 of the section 11. The elastic plug 16 is mounted on a metal holder 19 which is then placed on the panel 17. The metal holder 19 is formed with a small central opening 20 for insertion of the needle of a syringe therethrough. The metal holder 19 functions as a stationary electrical contact of an electrical switch which is normally opened. A movable electrical contact 21 cooperating with the stationary contact 19 is normally spaced from the stationary contact 19 and is supported by a flexible shank 22, one end of which is fixed at 23 on the panel 17. The shank 22 may be formed as an integral portion with the contact 21. The movable contact 21 has a small central opening 24 in alignment with the central opening 20 of the stationary contact 19 so that the injection needle of a syringe can pass through the central opening 24.

A sample liquid is injected into the sample introduction section 11 of the apparatus by means of a syringe or microsyringe 25 and, after being vaporized, is conveyed by a carrier gas introduced from the carrier gas inlet 14 to the column 12. In the sample injecting operation, the needle of the syringe passes through the openings 20 and 24 of the electrical contacts 19 and 21 and then pierces the elastic plug 16. In this operation the front end of the cylinder of the syringe 25 engages with the movable electrical contact 21 to push it toward the stationary contact 19 so that these two electric contacts may become in contact with each other. The reference numeral 30 generally indicates an electrical on-off switch consisting of the stationary contact 19 and the movable contact 21. The switch 30 is inserted in an electrical circuit including means for producing an electrical signal for the sample introduction information. The leading wires are led out either directly from the electrical contacts 19 and 21 or indirectly from the panel and the flexible shank 22 if both the panel and the flexible shank are made of electrically conductive material. In the latter case the panel 17 may be grounded while the fixed end of the flexible shank 22 may be connected to an electrically conductive terminal core 31 which is then connected to a leading wire. The reference numeral 23 indicates an insulating terminal support for holding the terminal core 31 and the flexible shank 22.

In the above mentioned way, the on-off switch 30 consisting of the movable and stationary contact members is electrically closed whenever a sample is injected, thereby actuating a circuit which then provides a signal indicating "injection" or "introduction" to the recording section of the apparatus. FIG. 2 shows an example of the signal circuit. The signal circuit generally indicated by the reference numeral 40 includes the electrical switch 30 consisting of the movable contact 21 and the stationary contact 19, a power source 41, a resistor 42, and means 43 for producing an electrical

signal which is connected in parallel to the resistor 42. Means 43 for producing an electrical signal may be a relay or flip-flop which is used to provide a writing signal to a recorder 44. The stationary contact 19 may be grounded at 17 which may be the electrically conductive panel 17 illustrated in FIG. 1.

With the above arrangement according to the invention, while the injection needle of the sample injecting syringe is piercing through the silicon rubber plug 16 to inject a sample into the sample introduction section, that is, the syringe is pressing the movable contact 21 to the stationary contact 19, the switch consisting of the movable and stationary contacts 21 and 19 are kept in closed position, at the state of which the relay or the flip-flop 43 is energized to produce an electrical signal which is then transmitted to a recorder 44.

FIGS. 3 to 5 illustrate another embodiment of the invention. FIG. 3 is a perspective view showing the sample injecting section of a vapor phase chromatograph and a microswitch disposed adjacent thereto. The reference numeral 51 indicates the top plate or panel of a casing in which a chromatographic column (not shown) is supported. The panel 51 is bored with an opening 52 for insertion of a sample injection syringe (shown with reference numeral 69 in FIG. 5). The sample introduction section 53 for the column is disposed slightly below and coaxially with said opening 52. The reference numeral 54 indicates a microswitch holder which is formed in a shape of a rectangular, horizontally extending box. The holder 54 is supported on a pillar 55 vertically extending from the top surface of the panel 51 and deposited on a collar 56 which is secured on the pillar 55 by a set screw 57. The distance between the holder 54 and the panel 51 can be changed by adjusting the position at which the collar 56 is secured on the pillar 55. The holder 54 is provided with an adjust screw 58 which engages the pillar 55 so that the holder 54 may be secured on the pillar 55 at a desired horizontally orientated position. In FIGS. 3 to 5, the front head 65 of the holder 54 is oriented toward the center of the opening 52 of the panel.

A microswitch 60 is supported within the holder 54 by a bracket 54a. The microswitch 60 is provided with an on-off operating button 61 and a resilient blade 62 for actuating the button 61. The blade 62 may usually be in slight contact with the button 61. The blade 62 is fixed at its one end on the top surface of the housing of the microswitch 60. The free end 62b of the blade 62 is connected to the top end of a connecting rod 63 which vertically extends through a guide hollow 64 formed in the front head 65 of the holder 54. The connecting rod 63 is vertically slidable in the hollow 64. The connecting rod 63 extends through the opening 52 of the panel 51 and has a tongue 66 at its bottom end. The tongue 66 extends horizontally and has an opening 67 for insertion of the injection needle of the syringe 53 therethrough. The opening 67 of the tongue 66 is positioned in alignment with the axis of the sample introduction section 53 and the tongue 66 is usually kept spacedly from the top end of the sample introduction section 53.

As more clearly illustrated in FIG. 5 the sample introduction section 53 may comprise a tubular body 71, an elastic plug 72 made of silicone rubber covering the top opening of the tubular body 71, and a cap 73 covering the elastic plug. The cap 73 is secured to the tubular body 71 by screw threading so that the elastic plug 72

is clamped between them. The cap 73 also has a central opening 74 through which the needle of the syringe 69 can pass.

When the injection needle held by the injection syringe 69 is inserted into the sample introduction section 53, with the needle passing through the opening of the tongue 66 and the opening 74 of the cap 73 and then piercing the elastic plug 72, the injection of the sample into the tubular body 71 which is connected to a column can be achieved simply by operating the injection syringe 53. During the operation of piercing the needle of the syringe through the elastic plug 72, the syringe 53 engages the tongue 66 to move it downward. The movement of the tongue 66 in the downward direction is transmitted to the blade 62 which then pushes the button 61 for placing the microswitch 66 in an electrically closed position. During this operation the tongue 66 may be in contact with the top surface of the cap 73.

In the above way, the microswitch 60 is electrically closed whenever a sample is injected, thereby actuating a circuit which then provides a signal indicating "injection" to the recording section of the apparatus. The electrical circuit including means for producing an electrical signal may be constructed in the same manner as illustrated in FIG. 2 but it should be noted that the switch 30 in FIG. 2 should be replaced by the microswitch 60 illustrated in FIGS. 3 to 5.

In the embodiment illustrated in FIGS. 3 to 5, since the holder 54 may be rendered rotatable around the axis of the pillar 55 by loosening the screw 58, the holder 54 may be oriented to another sample introduction section (not shown) which may be constructed in the same manner as the sample introduction section 53 illustrated in FIGS. 3 to 5. It will be understood that any change in orientation of the holder 54 should be done after pulling up the connection rod 63 with the tongue 66 above the panel 61.

The electrical signal produced in response to the sample injection in such a manner as disclosed in the above may also be transmitted to a computer. The whole system including means embodying the present invention and a data processing system is illustrated in a block diagram of FIG. 6. The apparatus illustrated in FIG. 6 includes a vapor phase or liquid phase chromatograph 81 as the sample analysing system. The chromatograph 81 includes a chromatographic column and such means for introducing a sample into the chromatographic column by a syringe as shown in FIG. 1 or FIGS. 3 to 5. The apparatus also includes a detector 82 which produces electric signals in response to the sample introduced into the column of the chromatograph 81. The detector 82 may be of any known type, e.g. in case of a vapor phase chromatograph, it may be a thermal conductivity cell or a flame ionization detector. The electric signal output from the detector 82 is amplified or attenuated by an amplifier or attenuator 83 and then imparted to a known recorder 44 to obtain a chromatogram. The output terminals 85 are also connected to normally open contacts 86a of a double-pole, double throw switch 86. The common contacts 86b of the switch 86 are electrically connected to a A-D converter 87, the digital output of which is then applied to a computer 88 which serves as data processing means. The normally closed contacts 86c of the switch 86 are electrically connected to a calculation start inhibition signal source 89. In this manner the computer 88 is se-

lectively connected by switching means in the form of a double pole, double throw switch 86 either to the detector 82 or to the calculation start inhibition signal source 89 so that the computer 89 may be supplied with the analytical data represented by electric signals, or, be inhibited from calculation operation, respectively.

The double-pole, double throw switch 86 is actuated by a relay coil 43. The circuit 40 for energizing the relay coil 43 may be substantially identical with that illustrated in FIG. 2 and includes an electric source 41 and a switch 30. The switch 30 is operatively connected to sample injecting means of the chromatograph 81. Preferably a second switch 84 which is manually operable is inserted in parallel with the switch 30. The second switch 84 is used for holding the circuit 40 in a conductive condition even if the first switch is opened after once closed.

So far as the switch 30 is not closed the relay coil 43 is never energized and accordingly, the common contacts 86b of the switch 86 are kept in contact with the normally closed contacts 86c so that the computer 88 is not supplied with any analytical data from the detector 82 but inhibited from calculation operation owing to the fact that the computer 88 is electrically connected through the common contacts 86b and the normally closed contacts 86c. The calculation start inhibition signal source 89 may supply a negative voltage signal or a sufficiently large positive voltage signal to the computer 88 through the A-D converter 87. In case where a negative voltage signal is applied to the computer 88, the computer will be able to discriminate any input signals, if applied to the computer, not to be calculated by means of code bit representing a negative sign obtained from an accumulator contained in the computer. In the case where a sufficiently large positive voltage signal is applied to the computer, the computer discriminates the input signals as not to be calculated as well, by virtue of overflow bits owing to said large signal.

As mentioned before, if a sample is injected to the chromatographic column, by means of a syringe, the first switch 30 is closed to energize the relay 43 which in turn operates to switch the common contacts 86b from the normally closed contacts 86c to the normally open contacts 86a so that the A-D converter 87 and the computer 88 is released from the inhibition of calculation operation and is supplied with analytical data which corresponds to the signal values obtained as a chromatogram at the recorder 44. Thus, the initiation of the introduction of a sample to the chromatographic column is exactly synchronized with the initiation of the supply of the analytical data to the computer which in turn starts the data processing as it is in an operational state so that the determination of the retention time of each of the sample constituents can be expected with a high accuracy.

The manually operable second switch 84 should be closed after the first switch is closed and before the first switch is opened at the termination of the sample introduction. Preferably, the second switch is closed after the lapse of the retention time of any sample constituent to be analyzed so that calculation operation may be continued even after the introduction of a sample to the column is terminated. If the two switches 30 and 84 are opened, the relay coil 43 is denergized to return the common contacts 86b to the initial positions at which

the A-D converter 87 and the computer 88 are electrically connected to the calculation start inhibition signal source 89 again.

In the above described embodiment of the invention, the calculation operation of the computer 88 is started in synchronism with the initiation of the sample introduction. However, the present invention is never limited to the synchronism of the initiation of the sample introduction with the start of calculation operation in the computer but applicable to the synchronism of the sample introduction with the start of the general supply of the analytical data to the computer when the computer is kept at the inhibition state of the calculation operation. For example, the invention can be applied to the so-called TSS (Time Sharing System) in which the supply of the data to the computer is carried out at the different time from that during which the calculation is carried out.

What we claim is:

- 1. Apparatus for providing a signal indicating introduction of a sample to be analyzed into a sample introduction section of a sample analyzing system by a syringe having an injection needle which punctures a plug covering the opening of the sample introduction section, comprising:
  - a first member positioned adjacent the sample introduction opening for engagement and movement with the syringe when a sample is injected into the sample introduction section;
  - a second member engageable by said first movable member; and
  - means for producing an output signal in response to engagement of said second member by said first member.
- 2. Apparatus as claimed in claim 1 wherein: said first and second members form a normally open switch which is closed upon engagement of said first member with said second member.
- 3. Apparatus as claimed in claim 2 wherein: said second member is a metal cap which overlies the plug and includes an aperture to receive the needle.
- 4. Apparatus as claimed in claim 3 wherein:

said first member includes an aperture axially aligned with said aperture of said second member to receive the needle.

- 5. Apparatus as claimed in claim 4 wherein: said first member is supported by a flexible shank.
- 6. Apparatus as claimed in claim 1 wherein: said second member is a normally open microswitch which is closed upon engagement by said first member.
- 7. Apparatus as claimed in claim 6 wherein: said first and second members are mechanically coupled to a rotatable member for reorientation for use with another sample introduction section.
- 8. Apparatus as claimed in claim 2 wherein: said output signal producing means includes a flip-flop electrically coupled to said switch; and a recorder electrically coupled to said flip-flop.
- 9. Apparatus as claimed in claim 2 wherein: said output signal producing means includes a relay electrically coupled to said switch; and a recorder electrically coupled to said relay.
- 10. Apparatus as claimed in claim 1 including: detection means responsive to said output signal producing means for detecting sample information; data processing means; means for inhibiting the operation of said data processing means; and means for selectively connecting said data processing means to said detection means and said inhibiting means.
- 11. Apparatus as claimed in claim 10 including: a manually operable switch for maintaining an electrical connection between said output signal producing means and said data processing means upon disengagement of said first member with said second member.
- 12. Apparatus as claimed in claim 1 including: detection means responsive to said output signal producing means for detecting sample information; computer means electrically connected to said detection means.

\* \* \* \* \*

45

50

55

60

65