



INTERNATIONAL APPLICATION PUBLISHED UNDER THE PATENT COOPERATION TREATY (PCT)

(51) International Patent Classification ⁶ : C10L 1/18, C10M 105/32, C11C 3/02	A1	(11) International Publication Number: WO 00/05327 (43) International Publication Date: 3 February 2000 (03.02.00)
<p>(21) International Application Number: PCT/US99/16669</p> <p>(22) International Filing Date: 22 July 1999 (22.07.99)</p> <p>(30) Priority Data: 60/094,076 24 July 1998 (24.07.98) US</p> <p>(71) Applicant (for all designated States except US): LOCKHEED MARTIN IDAHO TECHNOLOGIES COMPANY [US/US]; P.O. Box 1625, Idaho Falls, ID 83415-3899 (US).</p> <p>(72) Inventors; and (75) Inventors/Applicants (for US only): GINOSAR, Daniel, M. [US/US]; 915 Pescadero Place, Idaho Falls, ID 83404 (US). FOX, Robert, V. [US/US]; 3688 Woodhaven Lane, Idaho Falls, ID 83404 (US).</p> <p>(74) Agent: GOODSON, W., Gary; Lockheed Martin Idaho Technologies Company, P.O. Box 1625, Idaho Falls, ID 83415-3899 (US).</p>	<p>(81) Designated States: AE, AL, AM, AT, AU, AZ, BA, BB, BG, BR, BY, CA, CH, CN, CU, CZ, DE, DK, EE, ES, FI, GB, GE, GH, GM, HR, HU, ID, IL, IS, JP, KE, KG, KP, KR, KZ, LC, LK, LR, LS, LT, LU, LV, MD, MG, MK, MN, MW, MX, NO, NZ, PL, PT, RO, RU, SD, SE, SG, SI, SK, SL, TJ, TM, TR, TT, UA, UG, US, UZ, VN, YU, ZA, ZW, ARIPO patent (GH, GM, KE, LS, MW, SD, SL, SZ, UG, ZW), Eurasian patent (AM, AZ, BY, KG, KZ, MD, RU, TJ, TM), European patent (AT, BE, CH, CY, DE, DK, ES, FI, FR, GB, GR, IE, IT, LU, MC, NL, PT, SE), OAPI patent (BF, BJ, CF, CG, CI, CM, GA, GN, GW, ML, MR, NE, SN, TD, TG).</p> <p>Published With international search report.</p>	
(54) Title: A PROCESS FOR PRODUCING BIODIESEL, LUBRICANTS, AND FUEL AND LUBRICANT ADDITIVES IN A CRITICAL FLUID MEDIUM		
<p>(57) Abstract</p> <p>A process for producing alkyl esters (116) useful in biofuels and lubricants by transesterifying glyceride- or esterifying free fatty acid containing substance feed (100) in a single critical phase medium (104) providing increased reaction rates, decreased loss of catalyst or catalyst activity and improved overall yield of desired product. The process involves the steps of dissolving glyceride- or free fatty acid-containing substance feed (100), such as animal fats, vegetable oils, rendered fats, and restaurant grease, with an alcohol stream (102) or water stream (106) into a critical fluid medium (104); reacting in reactor (10) the said mixture over either a solid or liquid acidic or basic catalyst and sequentially in separator (14) separating the products from each other and from the critical fluid medium (104), which critical fluid medium (104) can then be recycled back in the process.</p>		

FOR THE PURPOSES OF INFORMATION ONLY

Codes used to identify States party to the PCT on the front pages of pamphlets publishing international applications under the PCT.

AL	Albania	ES	Spain	LS	Lesotho	SI	Slovenia
AM	Armenia	FI	Finland	LT	Lithuania	SK	Slovakia
AT	Austria	FR	France	LU	Luxembourg	SN	Senegal
AU	Australia	GA	Gabon	LV	Latvia	SZ	Swaziland
AZ	Azerbaijan	GB	United Kingdom	MC	Monaco	TD	Chad
BA	Bosnia and Herzegovina	GE	Georgia	MD	Republic of Moldova	TG	Togo
BB	Barbados	GH	Ghana	MG	Madagascar	TJ	Tajikistan
BE	Belgium	GN	Guinea	MK	The former Yugoslav Republic of Macedonia	TM	Turkmenistan
BF	Burkina Faso	GR	Greece	ML	Mali	TR	Turkey
BG	Bulgaria	HU	Hungary	MN	Mongolia	TT	Trinidad and Tobago
BJ	Benin	IE	Ireland	MR	Mauritania	UA	Ukraine
BR	Brazil	IL	Israel	MW	Malawi	UG	Uganda
BY	Belarus	IS	Iceland	MX	Mexico	US	United States of America
CA	Canada	IT	Italy	NE	Niger	UZ	Uzbekistan
CF	Central African Republic	JP	Japan	NL	Netherlands	VN	Viet Nam
CG	Congo	KE	Kenya	NO	Norway	YU	Yugoslavia
CH	Switzerland	KG	Kyrgyzstan	NZ	New Zealand	ZW	Zimbabwe
CI	Côte d'Ivoire	KP	Democratic People's Republic of Korea	PL	Poland		
CM	Cameroon	KR	Republic of Korea	PT	Portugal		
CN	China	KZ	Kazakstan	RO	Romania		
CU	Cuba	LC	Saint Lucia	RU	Russian Federation		
CZ	Czech Republic	LI	Liechtenstein	SD	Sudan		
DE	Germany	LK	Sri Lanka	SE	Sweden		
DK	Denmark	LR	Liberia	SG	Singapore		
EE	Estonia						

**A PROCESS FOR PRODUCING BIODIESEL, LUBRICANTS, AND FUEL
AND LUBRICANT ADDITIVES IN A CRITICAL FLUID MEDIUM**

CONTRACTUAL ORIGIN OF THE INVENTION

5 The United States has rights in this invention pursuant to Contract No. DE-AC07-94ID13223 between the U.S. Department of Energy and Lockheed Martin Idaho Technologies Company.

RELATED APPLICATION

10 This application claims priority from provisional application S/N 60/094,076 filed July 24, 1998.

BACKGROUND OF THE INVENTION

Field of the Invention

15 The present invention relates to a process for producing biofuels as alternatives or additives to currently used petroleum-based automotive or other vehicular fuels and lubricants by reacting fats and oils such as triglycerides and free fatty acids in a single critical phase to provide increased reaction rates and decrease the loss of catalyst or catalyst activity. The invention includes the transesterification of triglyceride- containing
20 substances and esterification of free fatty acid- containing substances with alcohol to produce alkyl esters of triglycerides, a desirable additive or alternative for petroleum diesel fuel or lubricants.

Description of the Prior Art

25 Significant quantities of esters such as triglycerides and free fatty acids are available from inexpensive feedstocks such as, animal fats, vegetable oils, rendered fats, restaurant grease and waste industrial frying oils. The triglyceride esters can be reacted, or transesterified, with alcohol to produce glycerol and the alkyl esters, and the free fatty acid can be reacted, or esterified, with alcohol or water to produce the alkyl ester. These
30 alkyl esters create desirable additives or alternatives to petroleum diesel fuel as well as

other high value end products such as detergent surfactants, herbicides, pesticide diluents, sticking agents, or lubricating additives for hydraulic and transmission fluids to name a few. Consequently, numerous patents exist dealing with processes surrounding transesterification of triglycerides and esterification of free fatty acids with alcohols such as methanol, ethanol or butanol to create the corresponding alkyl esters. U. S. Patents 5,713,965 and 5,525,126, incorporated herein by reference, are examples of such processes.

The transesterification or esterification reaction is normally carried out in an excess of the stoichiometric quantity of alcohol and a catalyst, usually a base such as potassium hydroxide although, the reaction can also proceed with an acid catalyst as well. In addition to creation of the alkyl esters, the transesterification reaction also produces glycerol.

Traditionally, triglyceride transesterification requires a multiple step process with one or more batch reactors. Initially, the triglycerides and alcohol form two immiscible liquid phases. As the reaction proceeds, two separate liquid phases form. One contains the newly formed alkyl esters of the triglyceride and the other the glycerol with the excess alcohol, catalyst and feed oil being dispersed into both phases. The reaction time for each step typically is measured in hours and once completed the liquid products must be allowed sufficient time to separate phases before additional processing and separation steps can occur to produce the final products. Excess alcohol must be recycled and the unused catalyst typically must be neutralized.

Even the most efficient of the traditional processes require multiple hours to process each batch of feed. Additionally, significant problems arise in the separation steps. Significant quantities of glycerol left in the alkyl esters diminishes the quality of the diesel fuel and likewise contaminated glycerol also loses much of its value compared to pure uncontaminated glycerol. Traditionally the separation procedures necessary to adequately clean the two product streams produces large quantities of waste water thereby creating additional cost and/or process complexity.

SUMMARY AND OBJECTS OF THE INVENTION

This invention provides a single-phase process for producing alkyl esters useful as biofuels and lubricants by the reactions of triglyceride esters and free fatty acids. This invention teaches a process where the reactants enter a reactor, whether batch or
5 continuous, dissolved in a critical fluid. The critical fluid provides a single-phase medium in which diffusion of the reactants into different liquid phases is eliminated, and mass transfer limitations are essentially eliminated thereby increasing the overall reaction rate. A critical fluid is a fluid whose temperature is within 20% of the critical temperature of the fluid as measured in Kelvin and pressure within 0.5-15 times the critical pressure as
10 modified by any co-solvent.

Additionally, the solubility of the reaction products such as alkyl esters in the critical fluid can be controlled by controlling the reactor's temperature and pressure. Where a reaction product's solubility is low or nonexistent such as glycerol it drops out of the fluid as it is created, thereby driving the reaction equilibrium toward product
15 production which significantly reduces the quantity of excess reactants such as alcohol needed to drive the reaction to completion.

The use of a critical fluid also allows for a wide range of catalysts, both liquid phase and reusable solid phase acid or base catalysts. Solid phase catalysts have significant additional advantages by limiting unwanted side reactions and producing
20 higher conversion rates of the desired products.

With the reaction completed, the critical fluid medium also facilitates clean, efficient separations. The reaction products typically can be sequentially and selectively removed from the critical fluid medium by adjusting the temperature and pressure of the critical fluid medium. In a transesterification reaction of triglycerides, the glycerol is
25 removed first leaving the alcohol esters in the critical fluid. With the glycerol removed, the temperature and pressure is again changed to drop out the alkyl esters. Once the products are removed the critical fluid and any excess reactants are returned to the beginning of the process.

It is the object of the present invention to provide a process for reacting triglyceride- and free fatty acid- containing substances capable of completing the reaction in significantly less time than present conventional processes.

5 It is another object of the present invention to provide a process for reacting triglyceride- and free fatty acid- containing substances capable of using reusable catalyst thereby avoiding the need for process neutralization.

It is yet another object of the present invention to provide a process for reacting triglyceride- and free fatty acid- containing substances capable of using a solid phase catalyst.

10 It is yet another object of the present invention to provide a process for reacting triglyceride- and free fatty acid- containing substances with higher yields of desired product over conventional processes.

15 It is yet another object of the present invention to provide a process for reacting triglyceride- and free fatty acid- containing substances capable of operating in a single phase, thereby eliminating immiscible liquid phases and reducing mass transfer reaction limitations.

It is yet another object of the present invention to provide a process for reacting triglyceride- and free fatty acid- containing substances with improved separation capabilities for separating purified reaction products without the need for washing steps.

20 It is yet another object of the present invention to provide a process for reacting triglycerides and free fatty acids which can quantitatively react the triglycerides or free fatty acids with significantly less excess alcohol than present processes.

BRIEF DESCRIPTION OF THE DRAWINGS

25 In order that the manner in which the above-recited and other advantages and objects of the invention are obtained, a more particular description of the invention briefly described above will be rendered by reference to specific embodiments thereof which are illustrated in the appended drawings. Understanding that these drawings depict only typical embodiments of the invention and are not therefore to be considered

to be limiting of its scope, the invention will be described and explained with additional specificity and detail through the use of the accompanying drawings in which:

Figure 1 is a simplified flow diagram which illustrates an embodiment of the invention employing a continuous reactor.

5

DETAILED DESCRIPTION OF THE PREFERRED EMBODIMENTS

The present invention describes a process for reacting organic compounds having the generic formula R_1COOR_2 with short-chain (C_1 to C_4) alcohols in a single critical fluid phase medium over an acidic or basic catalyst to produce alkyl esters suitable as a biodiesel fuel. One skilled in the art will recognize that organic compounds from the family of compounds known as acylglycerols, fats, oils, waxes, or free fatty acids have the general formula R_1COOR_2 . One skilled in the art will also recognize that acylglycerols can be mono, di, or tri substituted in any manner. The invention includes the transesterification and esterification of R_1COOR_2 molecules with short-chain alcohols such as methanol, ethanol, propanol, or butanol to produce alcohol esters. The invention also encompasses the acid and base catalyzed hydrolysis of R_1COOR_2 compounds in a single critical fluid medium where R_1 is a chain of aliphatic hydrocarbons (C_4 to C_{36}), and where R_2 can either be glycerol or can be another aliphatic hydrocarbon chain (C_4 to C_{36}) linked to R_1 via the carboxylic ester (BCOO-) linkage. The reaction is generally described as follows:

20

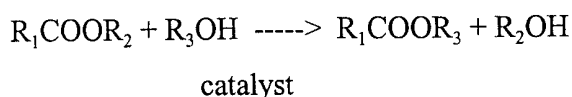

25

In the case of mono-, di-, and triglycerides, fats and oils, R_1 is the aliphatic hydrocarbon (C_4 to C_{24}) chain, R_2 is glycerol and R_3 is a hydrocarbon group, and preferably short chain alkyl group, more preferably methyl, ethyl, propyl, or butyl group attached to the alcohol. In the case of free fatty acids, R_1 is the aliphatic hydrocarbon chain wherein the terminal carboxylic acid group could be R_1COO^- , or R_1COOH , or $R_1COO^- M^+$ where M^+ is a metal (thus, the salt of a fatty acid); and, R_3 is the short-chain hydrocarbon attached to the alcohol. In the case of a wax, R_1 is an aliphatic hydrocarbon chain linked to R_2 via

the carboxylic ester linkage, and R_3 is the short-chain hydrocarbon attached to the alcohol.

Figure 1 provides a basic flow diagram for the glyceride reaction process employing a continuous reactor. Throughout the description of the process diagram, the various process vessels will be numbered between 1 and 99, with the various process streams being numbered beginning with 100. While the following discussion will describe a continuous reactor process for a transesterification reaction of glycerides with an alcohol ROH, one skilled in the art will recognize the process principles apply equally well in other process settings such as ones using batch reactors and separation processes as well as reactions producing alternate products to the alcohol esters as well as processes beginning with fatty acid feeds.

A glyceride containing feed **100** is mixed with an input alcohol stream **102**. The choice of alcohol will be a function of the desired reaction product, and typically such alcohols as methanol, ethanol, propanol and butanol are chosen for practical reasons, however, one skilled in the art will readily recognize the flexibility of choices and non-limiting aspect of the above list. This input alcohol stream **102** contains approximately a stoichiometric quantity of alcohol necessary to quantitatively react the input glyceride feed **100**. While the reaction will require some excess alcohol, that needed excess is contained in a critical fluid recycle stream **104** which provides a transport medium that solvates the reactants to create the required process conditions. The exact critical fluid employed for a given reaction will depend on specifically chosen process parameters such as temperature, pressure, desired reaction products, solubility of the reaction products, quantity of excess alcohol needed to drive the reaction to completion, post reaction separation processes and chosen catalyst. Examples of possible critical fluid solvents are carbon dioxide, sulfur dioxide, methane, ethane, propane, or mixtures thereof, with or without critical fluid co-solvents such as methanol, ethanol, butanol or water. Naturally, to the extent quantities of the critical fluid are lost during the process they can be replenished with a critical fluid make-up stream **106**.

The mixing of the input feed 100 (substance containing free fatty acids and/or glycerides), the input alcohol 102, the critical fluid recycle 104 and critical fluid make-up 106 streams creates a reactant input stream 108 which is fed into a continuous reactor 10. The temperature and pressure of the reactant input stream will depend on its components and the desired process parameters. The important criteria for the critical fluid is its ability to dissolve the reactants. Reaction temperatures should be within 20% of the critical temperature of the fluid as measured in Kelvin, and pressures within 0.5-15 times critical pressure as modified by any co-solvent. Reaction temperatures are typically in the range from about 20 to 200 degrees C with reaction pressures in the range from about 150 psig to 4000 psig.

The transesterification reaction generally proceeds in the presence of a catalyst, either acidic or basic. Liquid acids and bases, such as the common inorganic acids HCl, H₂SO₄ and HNO₃ and inorganic bases NaOH and KOH typically provide the needed catalytic activity. Additionally, the use of a critical fluid medium allows for use of a solid phase catalysts with either acidic or basic surfaces such as microporous crystalline solids, such as zeolites, and non-crystalline inorganic oxides such as alumina, silica, silica-alumina, boria, oxides of phosphorus, titanium dioxide, zirconium dioxide, chromia, zinc oxide, magnesia, calcium oxide, iron oxides, unmodified, or modified with chlorine, fluorine, sulfur or an acid or base, as well as mixtures of the above group or an exchange resin with either acidic or basic properties. Where solid catalysts are used in the reactor 10, they may create a catalytic packed bed or float free inside the reactor.

As the reaction proceeds, glycerol and the alkyl esters of the glyceride are produced. Glycerol has low solubility in critical fluids such as CO₂ and propane which will cause the glycerol product to drop out of the critical fluid medium. This removal of the glycerol from the reaction phase of the critical fluid medium will enhance the reaction equilibrium and drive the reaction further to completion with limited excess alcohol. One skilled in the art will then recognize that the quantity of excess alcohol required to drive the reaction to completion will depend not only on such factors as the desired reaction rate, but also the glycerol solubility in the chosen critical fluid.

The ability of the critical fluid medium to solvate the reactants eliminates the immiscible phases found in conventional processes. The single phase reaction eliminates inter-phase mass transfer of the individual reactants and catalyst, thereby greatly increasing the reaction's rate.

5 After completion of the reaction the reaction vessel may be the separation vessel, a final product stream **110** exits the reactor **10** and enters a first product separator **12**. In the first product separator **12** the product stream's temperature and/or pressure are modified to allow the least soluble product in the critical fluid to quantitatively drop out, the glycerol in this embodiment. Once the glycerol has dropped out of the critical fluid
10 medium, a physical separation of the two phases can be readily accomplished. A glycerol product stream **112** and a glycerol depleted product stream **114** exists the first separator **12**. The glycerol depleted product stream **112** consists of the critical fluid, excess alcohol, alcohol ester of the glycerides and any remaining catalyst, if a liquid catalyst is used, and then enters a second product separator **14**. Again the temperature and
15 pressure of the critical fluid are lowered to allow the desired product, the alkyl ester of the glyceride of this embodiment, to drop out of the critical fluid while retaining the excess alcohol in the critical fluid. The physical separation of the two phases then creates a second product stream of the alcohol ester **116** and the critical fluid recycle **104** which will be reintroduced back into the front of the process after having its pressure and
20 temperature restored to the original input reaction requirements.

While this embodiment describes a process with two product streams, the glycerol and alkyl ester, it should also be apparent to one skilled in the art that a reaction producing more than two products can produce multiple product streams by simply increasing the number of product separators.

25 Although the present invention has been described with reference to preferred embodiments, those skilled in the art will recognize that changes may be made in form and detail without departing from the spirit and scope of the invention.

WE CLAIM:

1. A process for producing alkyl esters useful in biofuels and lubricants by reacting glyceride- or free fatty acid- containing substances in a critical fluid medium, said process comprising the steps of:
 - 5 (a) dissolving the glyceride- or free acid- containing substance and an alcohol or water input into a critical fluid; and
 - (b) reacting the glyceride- or free fatty acid- containing substance with an alcohol or water in the presence of a catalyst to produce final products.
- 10 2. A process as described in claim 1 wherein said alcohol is an ROH input, wherein R is a short chain alkyl group.
3. A process as described in claim 2 where said alcohol is chosen from among the group ethanol, methanol, propanol, butanol, isopropanol and isobutanol.
- 15 4. A process as described in claim 1 wherein said catalyst is a liquid catalyst.
5. A process as described in claim 1 wherein said catalyst is a solid catalyst.
- 20 6. A process as described in claim 4 wherein said liquid catalyst is an acid.
7. A process as described in claim 4 wherein said liquid catalyst is a base.
8. A process as described in claim 5 wherein said solid catalyst is an
25 inorganic oxide.
9. A process as described in claim 8 wherein said inorganic oxide is from among the group of alumina, silica, silica-alumina, boria, oxides of phosphorus, titanium dioxide, zirconium dioxide, chromia, zinc oxide, magnesia, ion exchange resins, silicate

catalysts, and calcium oxide either unmodified or modified with chlorine, fluorine, sulfur or an acid or base.

5 10. A process as described in claim 5 wherein said solid catalyst is an ion exchange resin with either acidic or basic properties.

 11. A process as described in claim 1 wherein said process further comprises the steps of:

- 10 (a) separating a glycerol product from said final products; and
 (b) separating an alkyl ester product from said critical fluid.

 12. A process as described in claim 11 wherein said process further comprises the step of recycling said critical fluid for use in a later reaction.

15 13. A process for producing alkyl esters useful in biofuels and lubricants by reacting a glyceride- containing substance in a critical fluid medium, said process comprising the steps of:

- (a) dissolving a glyceride- containing substance and an alcohol or water input into a critical fluid; and
20 (b) reacting the glyceride- containing substance and alcohol or water input in a reactor in the presence of a catalyst to produce final products; and
 (c) separating an alkyl ester product and a glycerol product from the reaction mixture.

25 14. A process as described in claim 13 additionally comprising the step of recycling said critical fluid for re-use in this process.

15. A process for reacting fatty acids in a critical fluid medium, said process comprising the steps of:

(a) dissolving a fatty acid- containing substance and an alcohol input into a critical fluid; and

5 (b) reacting the fatty acid- containing substance and an alcohol or water input in a reactor in the presence of a catalyst to produce final products; and

(c) separating an alcohol ester product and a glycerol product from the reaction mixture.

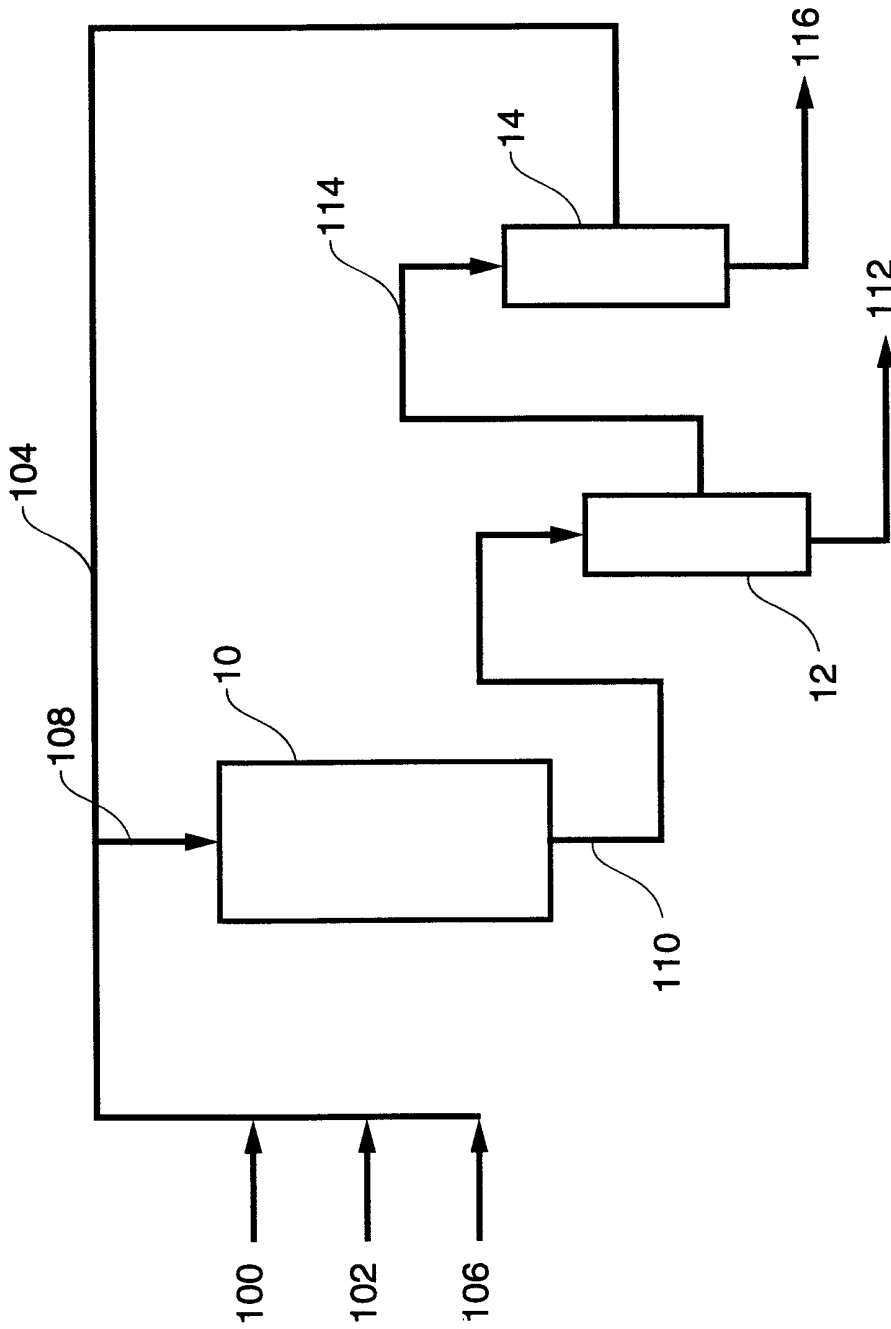

FIG. 1

INTERNATIONAL SEARCH REPORT

International application No.
PCT/US99/16669

A. CLASSIFICATION OF SUBJECT MATTER		
IPC(6) : C10L 1/18; C10M 105/32; C11C 3/02 US CL : 44/385, 388; 508/463; 554/167, 170, 174 According to International Patent Classification (IPC) or to both national classification and IPC		
B. FIELDS SEARCHED		
Minimum documentation searched (classification system followed by classification symbols) U.S. : 44/385, 388; 508/463; 554/167, 170, 174		
Documentation searched other than minimum documentation to the extent that such documents are included in the fields searched None		
Electronic data base consulted during the international search (name of data base and, where practicable, search terms used) None		
C. DOCUMENTS CONSIDERED TO BE RELEVANT		
Category*	Citation of document, with indication, where appropriate, of the relevant passages	Relevant to claim No.
Y	US 4,164,506 A (KAWAHARA et al) 14 August 1979, col. 2, line 45 to col. 4, lines 1-55.	1-8, 10-15
Y	US 4,695,411 A (STERN et al) 22 September 1987, col. 2, line 24 to col. 6, lines 1-45.	1--15
Y	US 4,698,186 A (JEROMIN et al) 06 October 1987, col.2, line 40 to col 6 lines 1-49.	1-15
Y	US 4,839,287 A (HOLMBERG et al) 13 June 1989, col. 1, lines 31-32.	1, 13 , 15
Y	US 5,219,744 A (KURASHIGE et al) 15 June 1993, col. 5, lines 10-14.	1,13 , 15
Y	US 5,480,787 A (NEGISHI et al) 02 January 1996, col. 3, lines 27-37.	1, 13, 15
<input checked="" type="checkbox"/> Further documents are listed in the continuation of Box C. <input type="checkbox"/> See patent family annex.		
* Special categories of cited documents:	*T* later document published after the international filing date or priority date and not in conflict with the application but cited to understand the principle or theory underlying the invention	
A document defining the general state of the art which is not considered to be of particular relevance	*X* document of particular relevance; the claimed invention cannot be considered novel or cannot be considered to involve an inventive step when the document is taken alone	
B earlier document published on or after the international filing date	*Y* document of particular relevance; the claimed invention cannot be considered to involve an inventive step when the document is combined with one or more other such documents, such combination being obvious to a person skilled in the art	
L document which may throw doubts on priority claim(s) or which is cited to establish the publication date of another citation or other special reason (as specified)	*g* document member of the same patent family	
O document referring to an oral disclosure, use, exhibition or other means		
P document published prior to the international filing date but later than the priority date claimed		
Date of the actual completion of the international search 18 OCTOBER 1999	Date of mailing of the international search report 04 NOV 1999	
Name and mailing address of the ISA/US Commissioner of Patents and Trademarks Box PCT Washington, D.C. 20231 Facsimile No. (703) 305-3230	Authorized officer <i>Margaret B. Medley</i> MARGARET B. MEDLEY Telephone No. (703) 308-0651	

INTERNATIONAL SEARCH REPORT

International application No.
PCT/US99/16669

C (Continuation). DOCUMENTS CONSIDERED TO BE RELEVANT

Category*	Citation of document, with indication, where appropriate, of the relevant passages	Relevant to claim No.
Y	US 5,520,708 A (JOHNSON et al) 28 May 1996, col. 3, line 15 to col. 4 lines 1-45 and col. 6 for Example 5.	1-11, 13-15
Y	US 5,525,126 A (BASU et al) 11 June 1996. cols. 3 and 4 and Figure 1.	1-5, 11-15
Y	US 5,578,090 A (BRADIN) 26 November 1966, col. 8, line 19 to col. 9 lines 1-44.	1-6, 13-15
Y	US 5,599,358 A (GIAVAZZI et al) 04 February 1997, col. 3, lines 1-13.	1-3, 13, 15
Y	US 5,713,965 A (FOGLIA et al) 03 February 1998, cols 4-6.	1-3, 11-15